

# A Sourcebook For the 1920's

Yurek Chodak  
Tadashi Ehara  
Harry Henderson  
Steve Perrin  
Sandy Petersen  
Greg Stafford  
Lynn Willis

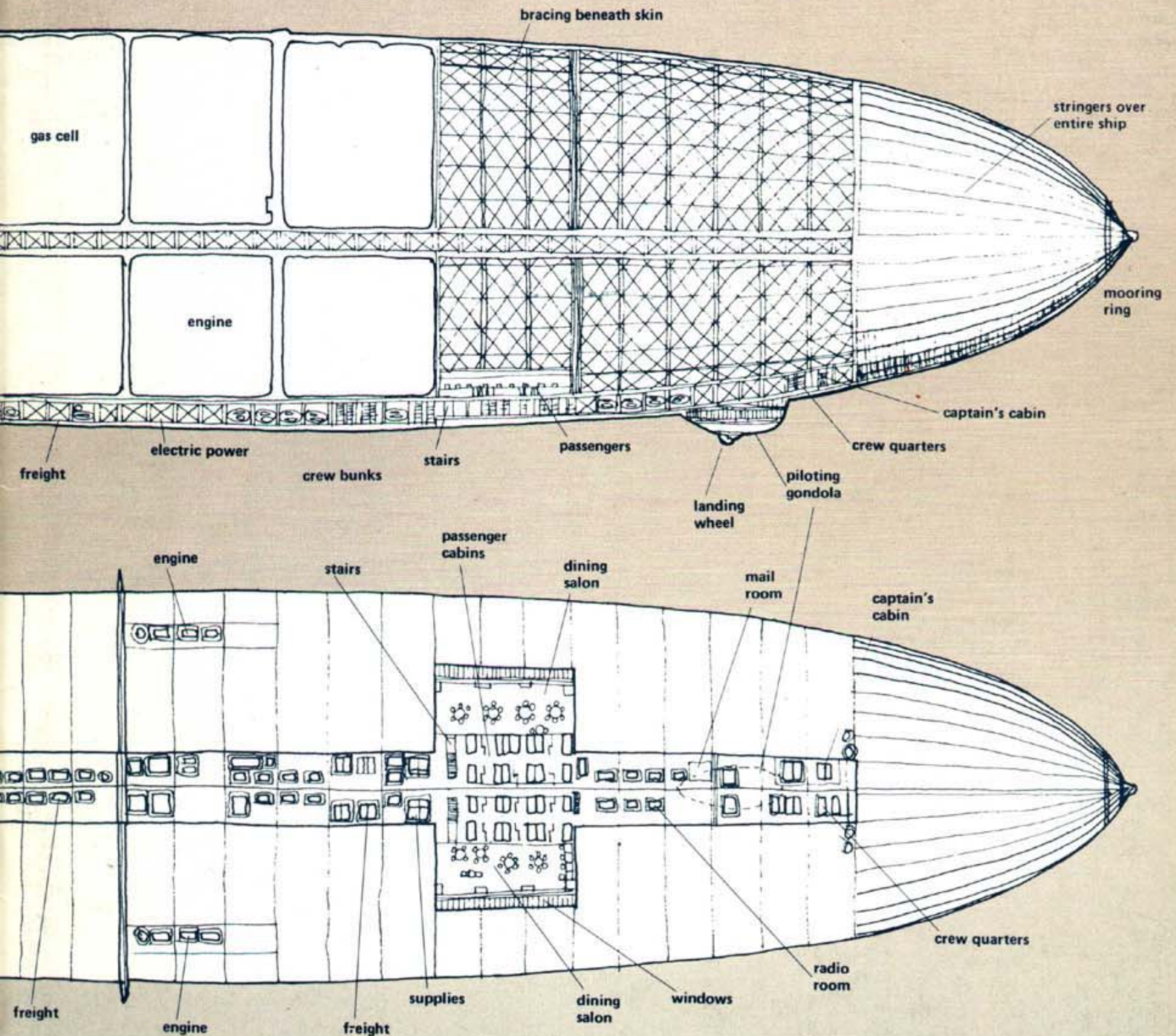

# A Sourcebook For the 1920's



Yurek Chodak, Tadashi Ehara, Harry Henderson, Steve Perrin,  
Sandy Petersen, Greg Stafford, Lynn Willis



## contents

TIMELINE FOR THE 1920s [Lynn Willis, Harry Henderson] . . .	2
Calendar for 1920. . . . .	4
BIOGRAPHIES [Lynn Willis] . . . . .	5
Catal Huyuk [Yurek Chodak] . . . . .	7
COMPANIES [Tadashi Ehara] . . . . .	8
CRIME . . . . .	8
About Arrests [Lynn Willis] . . . . .	8
Some History [Tadashi Ehara, Lynn Willis] . . . . .	9
Bribery [Lynn Willis, Steve Perrin] . . . . .	9
ON CULTISTS [Lynn Willis] . . . . .	10
OTHER OCCUPATIONS [Sandy Petersen] . . . . .	10
Nan Modol [Yurek Chodak] . . . . .	11
NAUTICAL SKILLS [Lynn Willis] . . . . .	12
SAGES [Lynn Willis] . . . . .	12
Map of the World [Rand McNally] . . . . .	13
Sketch Map of Rail Lines in the 1920s [Yurek Chodak] . . . . .	14
Ife, Scara Brae [Yurek Chodak] . . . . .	15
RAILWAY COACHES [Lynn Willis, Yurek Chodak] . . . . .	16
TRAVEL . . . . .	18
Transport Speeds [Lynn Willis, Steve Perrin] . . . . .	18
Thirty Largest Steamships . . . . .	18
Sample Distances, 1920 . . . . .	19
PRICES & CASH [Steve Perrin, Lynn Willis] . . . . .	20
Teotihuacan [Yurek Chodak] . . . . .	21
WEAPONS . . . . .	22
World Weapon Zones [Lynn Willis] . . . . .	22
New Weapons for CALL OF CTHULHU [Sandy Petersen] . . . . .	23
Weapons Notes [Steve Perrin] . . . . .	24
Black Market Weapons [Lynn Willis] . . . . .	24
Hasanlu, Mound City, Hal Saflieni [Yurek Chodak] . . . . .	25
BEASTS & MONSTERS [Sandy Petersen, Steve Perrin] . . . . .	26
BIBLIOGRAPHY [Lynn Willis] . . . . .	30
Luxor Temple [Yurek Chodak] . . . . .	30
Moundville, Xochicalco, Pan-P'o-T'sun [Yurek Chodak] . . . . .	31

### ABOUT THIS BOOK —

The Timeline was divided into three parts, so that referees could have a variety of viewpoints about the world. Every event recorded actually happened, or was represented as having happened in the case of the Fortean incidents. The timeline starts in 1890; it is supposed that most player-characters will not be born earlier than that year if they are active during the 1920's, but there is no proscription against older characters. The function of the timeline is to give referees and players common background.

I wish that the Biographies section could have been longer—the cast of characters of the day is remarkable. Their selection followed no plan, except that they seemed interesting to me, and might be interesting in a campaign. Everybody should have a chance to meet someone famous or infamous, or someone who one day will be. The judgments about the people are mine. They are considered judgments, but they are still judgments, and you should ignore them as you please.

Throughout the text there are site maps, mostly redrawn from the Hawkes book mentioned in the bibliography. The era was an important one for archaeology, and treasures have always had fascination for role-players. In most cases the maps were altered in some fashion which seemed to make the layout more amenable to play. They are still very accurate representations, though if you went to some of the sites in 1920 you would find that no spade work had been done. Whether or not the sites are being worked is a matter left to the referee. Often the sites were chosen as examples for fictional places which exploring adventurers might stumble across.

All of the prices, travel times, speeds, and so on depend very much upon just what year your game is in, and just where your game is set. Food prices are city prices; they may drop dramatically in the country, depending on the time of year (tomatoes in Vermont in January, 1920, are going to be very expensive, if in fact you can get them at all). Please remember that the information given is based on national yearly averages, and adjust it as you see fit.

This book adds quite a few new weapons to the basic *Call of Cthulhu* rules system. Their black-market prices are completely conjectural, as the die roll prices should indicate. Keepers are advised that they should either make such heavy weapons difficult to get, or should make sure that Investigators fully explore the consequences of owning such merchandise.

—Lynn Willis

A Sourcebook for the 1920s copyright © 1981,1983 by Chaosium Inc.; all rights reserved.  
Published in the UK by GAMES WORKSHOP Ltd, London, under licence from Chaosium Inc.  
Printed in Great Britain.



# Timeline for the 1920's

## IMPORTANT and LESSER EVENTS

- 1890** First entirely steel-framed building erected in Chicago; first electric tube railway in London.
- 1891** First practical hydroelectric station; beginnings of wireless telegraphy; first practical roll film
- 1892** Cape-Johannesburg railroad completed; crown top for bottles developed.
- 1893** World Exposition in Chicago; first working model of the Diesel engine.
- 1894** War between China and Japan; Captain Dreyfus exiled to Devil's Island; first wireless.
- 1895** Roentgen discovers X-rays; cigarette-making machine invented; Lumieres open their Cinematographie.
- 1896** Klondike gold rush begins; Addressograph patents confirmed; Ford makes first motor-car.
- 1897** McKinley is President of the U.S.; stencils are invented.
- 1898** Spanish-American War; disc recordings become practical; commercial aspirin appears; rules for present-day golf are established.
- 1899** Rutherford discovers alpha and beta rays.
- 1900** Boxer Rebellion in China; Peking legation siege; massive looting by occupation troops; Count Zeppelin launches 420-foot airship.
- 1901** President McKinley assassinated; T. Roosevelt becomes President; first trans-Atlantic wireless.
- 1902** Boer War; first steam turbine-driven passenger ship; modern macadam developed; safety razor patented; first alum-dried powdered milk; puffed cereals.
- 1903** Wright Bros. fly first heavier-than-air powered aircraft; first fluorescent light.
- 1904** Broadway subway opens in NYC; thermos flask patented; tracks (as opposed to wheels) first appear on farm machinery.

## THE UNIVERSE ACCORDING TO FORT, et. al.

- 1890** Alaskans see image of mysterious sky-borne city (16 March).
- 1891** Fresh snows inexplicably covered by layers of worms in Valley Bend district, Virginia.
- 1892** Unexplained explosions occur along the English Channel for several years; no evidence, damage, or explanation is ever found.
- 1893** A great luminous body passes over Virginia and North and South Carolina; visible 15-20 min.
- 1894** Pickering at Lowell Observatory sees conspicuous light floating above Mars (Nov. 14).
- 1895** Peasants near Odessa, Russia, attacked by strange beast.
- 1896** In the summer, hundreds of dead birds fall from the sky near Baton Rouge, Louisiana.
- 1897** Giant illuminated airship passes over Kansas City, Chicago, Texas, and W. Virginia (April).
- 1898** Phosphorescent strands of an asbestos-like substance fall on Montgomery, Alabama (Nov. 21).
- 1899** Strange yellow worms found strewn across an Alaskan glacier.
- 1900** A trickle of people appear across the world who speak no known language; many living and dead sea monsters reported.
- 1901** Alaskan Indians repeatedly report visions of a great airborne city.
- 1902** The *Freya* is discovered dismantled but otherwise undamaged; her crew is never found.
- 1903** Mud, ash, and fireballs fall across southeast Asia.
- 1904** At Wimbledon, England, an intense and inexplicable darkness occurs for 10 minutes (Apr. 17).

## NATURAL and MAN-MADE DISASTERS

- 1890** British cruiser *Serpent* wrecked in storm off the coast of Spain; 167 lost.
- 1891** Devastating quake levels 20,000 structures and kills 25,000 people in Japan.
- 1892** Fire and flood create a human hell at Oil City, Pennsylvania. 130 dead.
- 1893** Floods pushed by hurricane winds devastate U.S. South Atlantic coast; 2000 dead.
- 1894** Steamer *Walraro* wrecked off coast of N. Zealand; 134 lost.
- 1895** Building collapses in Ireland, killing 14.
- 1896** Railway collision kills 60, Reading, Penn.
- 1897** Three sampans collide off Sarawak; 138 die.
- 1898** Tropical cyclone hits south U.S. coast; hundreds die.
- 1899** Windsor Hotel in New York goes up in flames; millions in damage and 14 killed.
- 1900** Pier fire in Hoboken, N.J.; \$10 million damage and 326 killed.
- 1901** Pacific mail steamer *Rio de Janeiro* wrecked in San Francisco harbor; 128 lost.
- 1902** Steamer *Primus* sunk in collision with steamer *Hansa* on the Elbe River; 112 lost.
- 1903** Fire at Iroquois Theater, Chicago; worst theater fire in U.S. history (602 dead); disaster prompts fire codes across the nation.
- 1904** Steamship *General Slocum* catches fire near Manhattan; 1000 dead.

<b>1905</b>	Cullinan diamond (3000 carats) found, largest to that date; steam turbines standard for British navy; abortive revolution in Russia.	<b>1905</b>	Sheep are killed and their blood sucked from them (Badminton, Gloucestershire, Nov. 1).	<b>1905</b>	Japanese warship <i>Mikasa</i> sunk by explosion; 599 lost.
<b>1906</b>	U.S. troops occupy Cuba till 1909; <i>Lusitania</i> and <i>Mauretania</i> launched.	<b>1906</b>	'Typhoid Mary' is found.	<b>1906</b>	Earthquake and fire devastate San Francisco; 28,818 houses destroyed and 700 killed.
<b>1907</b>	Rasputin reaches the height of his influence in Czarist Russia.	<b>1907</b>	Balls of light fall from the sky and explode near Burlington, Vt. (2 July).	<b>1907</b>	Explosion on French battleship <i>Jena</i> kills 117 persons.
<b>1908</b>	Hermann Minkowski formulates his 4-dimensional geometry.	<b>1908</b>	A woman burns to death in her bed without the bedsheets being damaged or scorched (Blythe, England, March of the year).	<b>1908</b>	Steamer <i>Ying King</i> foundered off Hongkong; 300 lost.
<b>1909</b>	Robert E. Peary reaches the North Pole; first powered flight across the English Channel.	<b>1909</b>	Lighted airship repeatedly seen across New England (14-23 Dec.).	<b>1909</b>	Steamer <i>Seyne</i> sunk in collision with steamer <i>Onda</i> off Singapore; 100 lost.
<b>1910</b>	Murray and Hjort undertake the first deep-sea research expedition; paper cups invented.	<b>1910</b>	Fresh blood falls from sky in South America.	<b>1910</b>	Landslide buries many workers in the Norman open-pit mine, Virginia, Mn.
<b>1911</b>	Revolution in China leads to the republic under Sun Yat-Sen.	<b>1911</b>	"Ground found covered with masses of jellies the size of peas [and] contained numerous eggs of species . . . from which the larvae soon emerged." Eton, Bucks., England, 24 June.	<b>1911</b>	Forty tons of dynamite explodes at Communipaw terminal, N.J., killing 30.
<b>1912</b>	Wilson's cloud-chamber leads to the detection of protons, electrons; cellophane patented; Saville Row creates the WWI-named 'trench coat.'	<b>1912</b>	An intensely black object is seen upon the Moon, estimated to be 250 miles long by 50 miles wide (27 Jan.).	<b>1912</b>	<i>Titanic</i> rammed by iceberg, 1517 passengers and crew are lost.
<b>1913</b>	The Balkan War begins; Wilson inaugurated.	<b>1913</b>	Ambrose Bierce prepares for Mexico.	<b>1913</b>	British steamer <i>Calvadas</i> lost in blizzard in the Sea of Marmora; 200 lost.
<b>1914</b>	The Great War begins; first air raids take place; the first use of the Panama Canal.	<b>1914</b>	Manchester, England, reports a spindle-shaped object transitting the Sun (10 Oct.).	<b>1914</b>	Canadian Pacific steamship <i>Empress of India</i> sunk in collision with the <i>Storstad</i> in the St. Lawrence River; 1024 lost.
<b>1915</b>	The <i>Lusitania</i> is sunk; cereal flakes are marketed; the zipper is patented.	<b>1915</b>	Bright spots appear upon the Moon in December.	<b>1915</b>	<i>Lusitania</i> sunk by German submarine; 1199 lost.
<b>1916</b>	Pershing pursues Villa into Mexico; Halley's comet reappears.	<b>1916</b>	Red tides along the U.S. coasts.	<b>1916</b>	French auxiliary cruiser <i>Provence</i> sunk in the Mediterranean; some 3100 die.
<b>1917</b>	United States enters WWI; the Russian Revolution unfolds.	<b>1917</b>	Luminous objects seen moving on the Moon.	<b>1917</b>	Steamer <i>Castalia</i> wrecked on Lake Superior; 22 men lost.
<b>1918</b>	WWI ends; regular U.S. airmail service; world influenza epidemic kills 21.6 million; powered flight 150mph+, 30,000'+.	<b>1918</b>	Unusual weather in many parts of the world.	<b>1918</b>	U.S.S. <i>Cyclops</i> leaves the Barbados and is never heard of again.
<b>1919</b>	Prohibition enacted in U.S.; first trans-Atlantic flight (1880 miles in 16:12 hours).	<b>1919</b>	Captain James and his aircraft disappear over New York.	<b>1919</b>	French steamer <i>Chaonia</i> lost in Straits of Messina; 460 dead.
<b>1920</b>	Prohibition in effect in U.S.; Harding elected; the Bolsheviks win the Russian civil war; Allied occupation troops in Soviet Union mostly withdrawn; parachute and ripcord invented; first broadcasting station on the air.	<b>1920</b>	Shafts of light project from the Moon.	<b>1920</b>	Earthquake in Kansu province, China, kills 100,000.
<b>1921</b>	Rorschach devises his inkblot test; inflation of the German mark begins; KDKA broadcasts sports.	<b>1921</b>	Millions of tiny frogs suddenly appear in north London; more than a dozen ships disappear without a trace during the year.	<b>1921</b>	Bridge collapses, Chester, Penn.; 21 die.



# Biographies

*All of the following people actually lived.*

The 1920's were perhaps the apogee of personal literacy; most people actually wrote letters, and print was still an inexpensive medium for fact and fiction. In consequence, the era and the 60-70 years before it were, in what can be called the English-speaking universe, the best-recorded in history. From our point of view, the 1920's are also far enough back in time that we can begin to be objective about the events of that day in a way which we cannot be about events nearer to us. There is consequently a mass of information which even an army of scholars could not master. The following biographical sketches give a taste of the times and an indication of some historical currents; it may be amusing to run into some of these people as NPCs in the course of an adventure. Dates given are birth and death. If there is no death date, then the person lived on past 1930.

**Aguinaldo, Emilio (1869—)** Local anti-Spanish Phillipino revolutionary, he fought alongside the U.S. during the Spanish-American war, then, still seeking independence for the Philippines, he fought against the U.S. until he was captured by a ruse. He later adjusted to American rule, and lived to see full independence for his nation after WWII.

**Ataturk, Ghazi Mustapha Kemal (1881—)** Born in Salonika, the son of a Turkish customs official. As a lieutenant, he engaged in underground political activities, yet was also recognized as an excellent commander. A colonel by WWI, he gained national recognition for his defense of Gallipoli. He strove to block foreign partition of his nation. He was elected President of the new Turkish republic in 1923. He oriented Turkey toward the West throughout the 1920's.

**Berlin, Irving (1888—)** Born Israel Baline, he was originally a saloon singer. His first big hit was 'Alexander's Ragtime Band,' 1911. One of the most famous composers of his day, his most successful musicals included the Ziegfeld Follies (1919, 1920, 1927) and the Music Box Revues (1921, 1922, 1923, 1924).

**Besant, Annie (1847—)** This remarkable woman was by turns an Anglican minister's wife, a freethinker, prosecuted for obscenity while publishing sex education materials, a Fabian socialist, a theosophist, the international president of the Theosophical society, a Hindu, a founder of a Hindu college in Benares, India, interned for agitating for home rule for India during WWI, elected president of the Indian National congress, and the discoverer and firm advocate of J. Krishnamurti as the vehicle of the new Messiah—all accomplished with great verve and wit.

**Bierce, Ambrose (1842-1914?)** A famous journalist and author of his time, he long worked for the Hearst papers in San Francisco and Washington, D.C. He was lost during a journey to Mexico in 1914; the situation of his death remains unknown. Ascerbic and in range half-way between Poe and Samuel Johnson, he heavily influenced writers like Stephen Crane and H. L. Mencken. In the *Midst of Life* (1892, 1898), *Can Such Things Be* (1893), *Devil's Dictionary* (1911), *Collected Works* (1909-1912).

**Byrd, Richard Evelyn (1888—)** With an upper-class birth and education, he was a pioneer in naval aviation. He made polar aerial explorations in 1925 and 1926, circling the North Pole in the latter year. Now famous, he turned to the Antarctic and flew to the South Pole and returned in 1929. He led later U.S. Antarctic expeditions.

**Capone, Al "Scarface" (1899—)** Nominally born in Naples, Italy, Capone was a nationally-known U.S. gangster by 1920. Moving from Brooklyn to Chicago, he took control of the bootlegging industry and was the de facto ruler of Chicago in the late '20's and early 1930's. He was responsible for the St. Valentine's Day Massacre in 1929.

**Carnegie, Andrew (1835-1919)** Born poor, he worked his way up the Pennsylvania Railroad managerial ladder, and the Civil War confirmed his wealth. In the 1870's he put his capital into steel, and dominated the industry after 1880. Despairing of successfully competing, J. Pierpont Morgan bought out Carnegie's entire steel holdings in 1901 for 500 million dollars, and in the next 20 years Carnegie gave away about 350 million of that total. Believing that the wealthy must use their wealth for the good of the community, his most outstanding act of philanthropy was the funding of hundreds of new libraries across the U.S.

**Caruso, Enrico (1873-1921)** Born poor, he was the eighteenth child of a mechanic. In 1898 he electrified Milan with a historic triumph in 'Fedora'; offers came from every large opera company. Shortly after the turn of the century he appeared with the Metropolitan in New York, and thereafter was connected with it. At the peak of his career he made a half-million a year from opera, and was also a major sound recording star. He died in Naples, 2 Aug., 1921. He was probably the greatest tenor of the century. A generous and gracious man, he was mourned across the world.

**Chaplin, Charles (1889—)** Born poor, he was a popular British music hall performer by age 19. Sennett starred him in silent pictures beginning in 1910, and he thereafter progressively more and more controlled his artistic destiny. His fame dimmed when talking pictures changed the requirements for film success.

**Chiang Kai-Shek (1887—)** The son of a merchant, he was educated at military academies. He joined Sun Yat-Sen's ongoing revolution; in 1918-20 money speculations and cordial relations with Shanghai's 'Green Gang' improved his prospects for the future. He be-

came Sun's chief of staff in 1923; when Sun died Chiang took control of Sun's political party, the Kuomintang (KMT). In 1925-1928 he unified east and central China by force, though other areas of the old empire were held by war lords, communists, the Japanese, and European colonial powers. Chiang's famous purge of KMT communists was in the same year he married missionary-educated Soong Mei-Ling (1927).

**Chou En-Lai (1898—)** One of the most skilled diplomats alive during his lifetime, Chou had a traditional Chinese education. He became a Marxist about 1917, and travelled and organized Chinese students in Europe throughout the early 1920's. A communist and member of the KMT, he held Chinese government posts 1925-1926; he was purged by Chiang in 1927. He organized the famous Shanghai general strike in 1927, and escaped to the Soviet Union when it was quashed. Returning to China, he became the liason between Mao Tse-Tung and the CCP Central Committee in the early 1930's. A man persistently of the Middle Way, he tempered extremists and sharpened dullards throughout his life.

**Churchill, Winston Spencer (1874—)** With an upper-class but lonely childhood, he became a military man and journalist as soon as he reached his majority, and served in and wrote about Cuba, India, South Africa, and the Sudan between 1895-1899; in a world filled with dashing young journalists, he became almost the prototype with his Boer War escapades. MP in 1900; First Lord of the Admiralty 1912. The Gallipoli disaster lost him most public confidence, after which he activated his Army commission and served on the Western Front. He was in general political isolation throughout the 1920's.

**Du Bois, W. E. B. (1868—)** This famous black activist and scholar is the author of several landmark books, including *Suppression of the African Slave Trade* (1895) and *Black Reconstruction in America* (1935). One of the founders of the NAACP and a leading organizer of and theorizer about Pan-Africanism and the role of Black Africa in the history of the world. Ascerbic, incisive, controversial.

**Edison, Thomas Alva (1847—)** The most famous and the most honored American inventor: the stock ticker, the phonograph, the incandescent lamp, the electric power system, the first patent for wireless transmission, the first patent for motion picture, more. Always maintaining excellent media relations, Edison was the founder and organizer of modern industrial research.

**Einstein, Albert (1879—)** A German-born physicist, he hypothesized the Special and General theories of relativity (1905 and 1919) which essentially ended his creative work, a common-enough situation for theoreticians. As with Edison, he was able to maintain very good media relations, and with the advent of Nazism his Jewishness and his prominence thrust him frequently into roles of spokesman and letter-writer.

**Fitzgerald, Francis Scott Key (1896—)** This American author was a spare and precise writer of some importance, chiefly as a debunker of the Carnegie myth: Fitzgerald's self-made millionaires get their status by shady deals and are shallow hypocrites without capacity for self-reflection. He and Zelda were free-

spending alcoholics, and probably more people wished for their lifestyle than ever read his books.

**Ford, Henry (1863—)** The son of a farmer, he loved machines, and started his first auto company in 1899. It failed, but the second (1903) produced the Model A, and it succeeded. In 1909 he decided to produce only Model T Fords, and by 1913 he was selling 40,000 cars annually. He installed conveyor belts and thereby created the assembly line; he also raised his employees' wages to \$5 a day, nearly double the industry standard for the time. Continuing to produce Model T's until 1927, he lost the auto lead to GM, which took advantage of tailored marketing and advertising to divide his 'uniform' market. His isolationist political activities were inept and often controversial.

**Freud, Sigmund (1856—)** He laid the systematic foundations for consideration of the unconscious mind, for the meaning of dreams, for the study of pre-pubescent sexuality, for the understanding of neurotic behavior, and more. A seminal 20th century mind. Books include *The Interpretation of Dreams* (1901), *Three Essays on Sexuality* (1905), *Totem and Taboo* (1912), *Beyond the Pleasure Principle* (1920), and *The Ego and the Id* (1923). With rare exception, later psychological thought uniformly agrees with or departs from one man: Sigmund Freud.

**Gandhi, Mohandas Karamchand (1869—)** A lawyer and activist, he lived for many years in England and South Africa (1888-1915) and developed his ideas and techniques while in South Africa. His methods of passive civil disobedience and his unrelenting will for the independence of India contributed to the end of British control after WWII. The poet Tagore first called him 'Mahatmaji,' and he was usually so known thereafter. Intelligent, contradictory, fearless, dedicated.

**Gershwin, George (1898—)** Popular composer of songs, as well as longer works of more serious intent (*Porgy and Bess*, *An American in Paris*, etc.) which attempted with some success to fuse American popular music with black American musical concepts and with European classical forms.

**Goddard, Robert Hutchings (1882—)** Had a PhD in physics, and studied rocketry persistently. Published 'A Method of Reaching Extremely High Altitudes' in 1919. Experimented with rockets throughout the 1920's, and fired his first liquid-fueled rocket in 1926, near Auburn, Mass.

**Goldman, Emma (1869—)** American anarchist. Implicated in the attempted assassination of Frick, Carnegie's partner, (1899) she later ceased to advocate violence. Stood strongly for women's rights. Imprisoned several times. Though an early supporter, she disavowed the results of the Russian Revolution, 1923-1924. *Living My Life* (1931) is her autobiography.

**Goring, Hermann Wilhelm (1893—)** Upper-class child, and a flying ace for Germany in WWI; led Von Richtoffen's squadron after the Red Baron was downed; won all important German decorations. Met Hitler in 1922; became Munich Storm Troopers commander 1923. Won seat in Reichstag 1928.

**Hearst, William Randolph (1863—)** Upper-class child; began sensationalist journalism career with the *San Francisco Examiner*.

Moved his chain of newspapers away from 'hard' news and toward comics, sports, headlines, and columns, a trend that has generally continued. Supported a succession of mistresses and expensive hobbies, among them Marion Davies and the San Simeon estate. Held the world's largest private art collection. Always unsuccessful politically. Orson Welles' *Citizen Kane* is a fictionalized account of WRH.

**Hemingway, Ernest Miller (1898—)** Reporter, soldier, author, personality. Served Italy in WWI. In Paris during the 1920's. Known for his short stories and novels like *The Sun Also Rises* (1926) and *A Farewell to Arms* (1929). His life as a celebrity really starts during the Spanish Civil War and WWII.

**Hitler, Adolf (1889—)** Lower middle class child; his attempts at an artistic career failed during his teens, and he developed his anti-Semitic and Aryan Race mythologies. Fought with distinction in WWI; decorations include Iron Cross, First Class. A significant political force in Bavaria, 1923, his 'beer-hall putsch' failed and he was imprisoned for a year during which he wrote *Mein Kampf*. He had no solid national strength until the Depression.

**Hoover, John Edgar (1895—)** Made Acting Director of the FBI in 1924, he recruited top-notch specialists as agents in combatting crime. In the 1920's and 1930's the FBI was unparalleled in the United States for its trail-making use and methodical study of fingerprints, the ballistics laboratory, and what now seem elementary police training procedures.

**Houdini, Harry (1874-1926)** Born Erik Weisz, he was attracted to the circus at an early age, and began his show business career by doing tricks and magic. But his genius lay in performing escapes from cells, chains, caskets in rivers, strait jackets, and anything else his fertile mind could imagine. He was an expert publicist, but he also knew more about locks and their solutions than any other human, and was obsessed in following their details. He collected magic tricks, and filled rooms in his home with defunct props, posters, tools, and books of magic. He was also an indefatigable exposé of spiritualist fraud, as well as a star in many motion pictures. He died on Oct. 31, 1926, the victim of peritonitis caused by a mistaken blow from an admirer.

**Kroeber, Alfred Louis (1876—)** An anthropologist, Kroeber taught at UC Berkeley until he retired in 1946. His life's work was the description of the California Indians, but he also did major work on Zuni, Arapaho, and Peruvian archaeology topics. Probably the most widely-known and respected American anthropologist of his day. Also did extensive fieldwork and systemized previously unconnected areas of study.

**Lawrence, Thomas Edward (1888—)** Soldier, diplomat, writer, and mystic. A student of the Middle East and the Arabs in particular, Lawrence advised (and frequently led) Arab guerilla raids on Turkish positions during WWI. Their ingenious, flexible, and far-ranging tactics were in marked contrast to the ponderous military orthodoxies of the day, and he sometimes was in as much trouble with his superiors in Cairo as he was with the Turks. He stayed in government service after WWI, and was stationed in India near the Soviet frontier 1926-1928.

**Lenin, Vladimir Ilich (1870-1924)** Marxist theorist and revolutionary, nearly unique in the lasting impact of some of his writings and in his active political achievements. Upper-class child, a Marxist by his majority, he was soon imprisoned and exiled, and spent most of the next 20 years in Western Europe. His acumen and will led directly to the triumph of the Bolsheviks after the successive collapse of the Czarist and constitutional regimes. He was tireless, self-effacing, and intelligent, and his death occurred at an unfortunate time for his nation, rigidifying 'democratic centralism' into a form which could not adequately distinguish between thought and action. Works include *The Development of Capitalism in Russia*, *What's To Be Done?*, *The State and Revolution*, more.

**Lindbergh, Charles Augustus (1902—)** Upper middle class child, fascinated by flying. With St. Louis financial backing, *The Spirit of St. Louis*, a very fast monoplane, was built, and with it he flew from Roosevelt Field, Long Island, to Le Bourget Airport, near Paris, the first solo flight across the Atlantic. From this feat he received tremendous fame and popularity, May 20-21, 1927.

**London, John Griffith ("Jack") (1876-1916)** Author and socialist. A poor and illegitimate child, he held various jobs connected with the sea, then joined the Klondike gold rush, 1899. His experiences led to popular books like *The Call of the Wild* (1903), *The Sea Wolf* (1904), *White Fang* (1906), and *Martin Eden* (1909). His fiction gets power from stereotypes of Social Darwinist and Marxist ideas, mixed with liberal doses of the notion of female purity, also popular in the time.

**Mao Tse-Tung (1893—)** A middle class child, he did not become a communist until he studied for a time in Peking when he was about 25. He was a founding member of the Chinese Communist Party, and until the purge of 1927 was also a member of the Kuomintang, and worked as a coordinator between the two. Lacking sophistication, he was sent back to his home province, and spent the next years agitating and building a revolutionary base. By substituting the peasantry for the almost non-existent Chinese proletariat, Mao was able to depart from Comintern theory and find a suitable mode of operation in China. Even after the disasters of the purge and the Shanghai general strike, however, the central committee steadily retook power from Mao in his 'liberated' zone, and his authority eroded until the Tsunyi conference (1935) during the Long March.

**Mussolini, Benito (1883—)** The son of a blacksmith, he was from his early 20's a politician, journalist, and orator, urging reform at any cost. It was his genius to understand the unrest of the middle classes in Italy before and after WWI, and to offer a program theoretically granting all power to the workers which actually stifled and impoverished them, for which he and his party were greatly rewarded by the upper and middle classes. He took power in 1922, with the famous 'march' on Rome. By 1930 he was irrevocably in control of Italy, the conclusion of the decade being marked by accolades about him from Pope Pius XI.

**Peary, Robert Edwin (1856-1920)** An engineer, he was fascinated by the Arctic, and led a succession of land expeditions trying to

reach the North Pole. The eighth expedition reached the Pole by utilizing support teams to clear the way, somewhat in the fashion of a step rocket. His officially supported triumph was upstaged by prior claims of another explorer, but those claims were later discredited.

**Pershing, John Joseph ("Black Jack") (1860—)** Serving in the Philippines and other Asian posts, he was chosen to command the 1916 punitive expedition into Mexico in search of Pancho Villa. Though he failed in that effort, he was chosen because of his active service record to command the American Expeditionary Force dispatched to Europe. There he struggled mightily to retain the U.S. troops as an independent command which would otherwise have been fragmented between the Allies and (it seems likely) have been expended in early wave attacks. A stern, unfriendly man who had tragically lost his family, he did his utmost for his troops, and earned general respect.

**Reed, John Silas (1887-1920)** Rich and well-educated, Reed became a radical journalist who travelled the globe. He was a 'staff officer' for Pancho Villa. He covered the Great War in Germany, Russia, Serbia, Rumania, and Bulgaria. He witnessed the October Revolution in what would become Leningrad, and wrote '10 Days That Shook the World,' an inaccurate and inspiring book about it. He was named Soviet Consul-General in New York, but since the Soviet Union was not recognized by the United States government, neither was Reed. He died of typhus in Moscow, 1920, and was given a state funeral and burial in the Kremlin. Reed is an example of the many colorful and committed journalists of the day, of all political persuasions.

**Rockefeller, John Davison (1839—)** A middle-class child, he quickly showed an extraordinary talent for economy, efficiency, and organization, and was fortunate enough to have started in the oil business early in its development, helped immensely by the Civil War. By 1880 Rockefeller holdings refined 90% of American oil, owning all of its own support industries such as transport, storage, ships, and so on. Though Congress broke apart the Standard Oil Trust, in practice its policies continued to be coordinated after the Sherman Anti-Trust act. He had a personal fortune of 900 million in 1913, and gave away some 500 million dollars during his life. The Rockefeller Foundation was chartered in 1913. Rockefeller remained simple, frugal, and obsessed with work.

**Roosevelt, Theodore (1858-1919)** An upper-class child and Harvard Phi Beta Kappa, he was soon elected to the New York Assembly, and was thereafter a politician and author-lecturer except for a year or so spent ranching and writing on the Little Missouri river in Dakota Territory. He gained a justified reputation for honesty and energy in the various offices he held, and returned a war hero after the Spanish-American War. Elected governor of New York, he accepted the U.S. Vice-Presidential nomination two years later, and when McKinley was assassinated, became President in 1901. Though moving slowly at first, he used the Presidency frequently to promote conservationist and progressivist policies which have had very long-term effects. A try for re-election in 1912 split the Republican party and insured Wilson's victory.

**Stalin, Joseph (1879—)** The son of a Georgian cobbler, Stalin prepared for the ministry but was expelled for subversive activity. Though finally banished to Siberia, he escaped and joined the Bolshevik underground in the south. Stalin organized bank robberies and raids in the early part of the century which materially aided the international wing of the party (with Lenin at its head) as well as the local cells. He was finally caught in 1912 and exiled to the Arctic Circle, where he remained until 1917. He was a military commissar again in the south and several other fronts during the Civil War, then rose in standing during the next few years as Lenin's troubleshooter and finally as one of the three-man committee that administered party and nation after the death of Lenin. Over the next few years he engineered the exile of Trotsky, his only viable rival, and finally assumed full personal authority.

**Stefansson, Vilhjalmur (1879—)** A brilliant, mostly self-educated student and ethnologist, he came to the conclusion that the Arctic was hostile only when explorers treated it with contempt and did not bother to learn the Eskimo survival techniques. In proof of this theory, and confounding the ponderous Arctic expeditions of the day, Stefansson and two companions once travelled 500 miles across the moving ice of the Beaufort Sea with little more than light packs. A popular author and lecturer, his works can still be read with profit, especially by those who still divide humans into 'civilized' and 'uncivilized' categories. During and after the Depression he served as adviser, consultant, and compiler of survival techniques. If adventurers want to go a-travelling in the Arctic, they should find this man first.

**Sunday, William Ashley ("Billy") (1862—)** An orphan, Sunday was first a drifter and then an early major-league baseball player. Becoming a committed Christian, he was ordained in 1903, and quickly evolved a show-business style of religious presentation. The height of his career was in the second decade of the century. It was Billy Sunday who exhorted sinners to "put it over the plate for Jesus."

**Tesla, Nikola (1856—)** A Croatian-American inventor, he fathered the alternating electrical current system known throughout the world, as well as the induction motor, fluorescent lights, and more. He refused the 1912 Nobel Prize, offered as a joint award to him and to Edison. In the latter days of his career he experimented obsessively with the possibilities of broadcasted electrical power. He was reputed to have unusual powers of foresight and perception, and grew more and more reclusive as he grew older.

**Trotsky, Leon (1879—)** A middle class child, he was a Marxist by his late teens, whereupon he was exiled to Siberia, but escaped to Western Europe some time later. There he initially sided against Lenin and with the Mensheviks. Returning to St. Petersburg during the 1905 Revolution, he was again exiled to Siberia when it was put down, but he again escaped to the West and did not return to Russia till 1917. The Great War caused him and Lenin to reach more similar positions, and in the 1917 crisis in St. Petersburg he first provided strong allies for the Bolshevik cause, and then organized the actual seizure of power. During the Civil War Trotsky was commissar for war, and did a monumental job of creating a reliable

armed force under difficult circumstances. A brilliant thinker and orator, he was by nature incapable of constructing a firm factional base and Stalin rather quickly maneuvered him out of power—and then out of the country.

**Villa, Francisco ("Pancho") (1878-1923)** An orphaned peasant, he became a skillful fighter and organizer with Francisco Madero. Once Huerta had usurped the victory over Diaz, Villa again took the field, uneasily allied with Carranza and Zapata. In the confused years following, Villa was finally localized as a force in Mexico to Chihuahua, and was there assassinated. Villa attacked Columbus, N.M., in retaliation for the U.S. recognition of Carranza; Pershing's columns unsuccessfully chased Villa for months in return.

**Wells, Herbert George (1866—)** A lower middle class child, Wells originally trained as a science teacher, but forsook it upon the success of *The Time Machine* (1895). In the ten years following, he established or improved upon most of the classic themes of what is now called science fiction, in prose lucid with both political thought and symbolic sophistication. He then wrote a series of 'social problem' novels which also were successful. WWI corrupted his basic optimism, and after that usually saw his role as a popular educator on a mission to make mankind understand its own motives. He loved women and pursued them as long as he was able.

**Zapata, Emiliano (1879-1919)** Perhaps the 'saint' of Mexican revolutionaries, Zapata was single-minded in his determination to restore land to the control of those who worked it. He was rather like Lenin in his self-effacement (the opposite of swaggering Villa) and pursuit of final goals, but was much more gentle than Lenin in the actual application of force. If adventurers have to be captured by a revolutionary, this one will probably lecture them and take them to the border of Morelos and bid them good day.

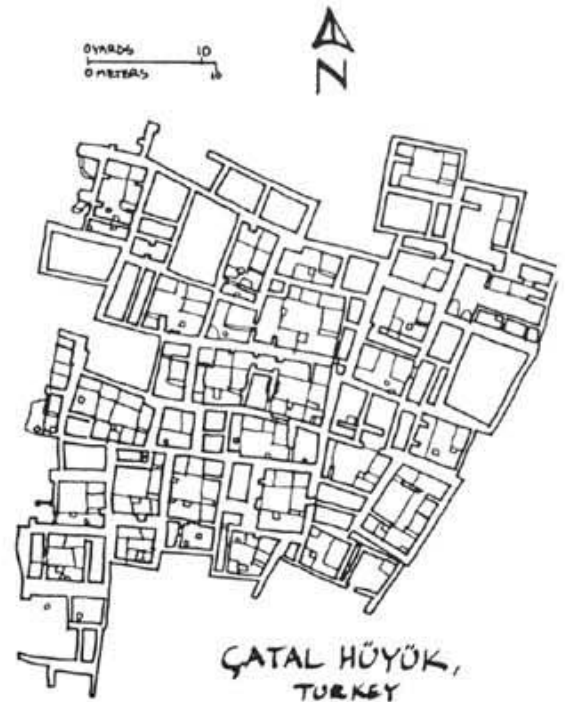

*This excavation is part of a larger mound. It dates from 7000-5500 B.C. What appear to be streets are actually walls—the citizens entered their homes from the rooftops.*



# Companies

Borden Milk. Campbell's condensed soup had nation-wide distribution. Food processing had become big business. But, whether they were canned, dried, or condensed, they didn't taste or look like what people were used to. Carnation evaporated milk, "Milk from contented cows." Dole canned pineapples, "It Cuts with a Spoon—Like a Peach." Coca-Cola came in bottles, "The pause that refreshes." Del Monte. Swift. Postum Cereal. Jell-O. Log Cabin syrup. Ting & Bettles. Birdseye's frozen foods. Betty Crocker. Wheaties. Gerber baby foods. Minnesota Valley Canning. "Green Giant." Heinz. The 5 cent Hershey bar. Hormel. Kellogg's Corn Flakes. Libby, Oscar Mayer. National Biscuit (Nabisco). Nestle. Pepsi-Cola. In 1929, Americans drank an average of 35.4 soft drinks (12 oz. bottles). Pillsbury. Quaker Oats. Aunt Jemima. Maxwell House coffee. Fleischmann. Chase & Sanborn coffee. Staley.

A&P. There were 70,000 milkmen with horse-drawn wagons. Jewel. Kroger. Safeway. Skaggs. Jolly Time popcorn.

The public loved Burlington's shiny new fabric, rayon. J. P. Stevens. Buster Brown shoes. Shirts with attached collars were introduced, "Only Arrow Shirts Have the Arrow Collar." Hookless fasteners (zippers) were perfected. Levi's jeans still had a rivet at the crotch. Thom McAn shoes. Black & Decker portable electric drills. Toastmaster pop-up toasters were introduced.

Avon. Gillette. Band Aids. Vicks VapoRub. Aspirin became a generic word. Walgreen drugstores.

Willys-Overland. Maxell Motor Car. Ford's Model T did about 35 mph. In 1924 Chrysler introduced the 6-cylinder Chrysler 50 that did 50 mph. DeSoto and Plymouth were introduced. Dodge. Autohorse. Gearless Steamer. Humpmobile. Roamer.

Kresge. J. C. Penny. Sears, Roebuck & Co. There were over 1000 Woolworth stores, nothing costing over 10 cents. Hale Bros. Dayton's. Macy's.

Arthur Murray Dance Studios. Pond's cold cream. Rinso soap. Jergens lotion. Sun Maid raisins. By 1929 there was a radio set in more than one-third of U.S. homes. Procter & Gamble popularized a new art form—soap sculpture.

Wall Street Journal. Barron's. Dow Jones ticker service. Douglas Fairbanks plugged Lucky Strike cigarettes. Charlie Chaplin plugged Old Gold cigarettes. Mary Pickford plugged Lux dishwashing soap. Charles Lindberg plugged Bulova "Lone Eagle" watches. Reader's Digest was available only through subscription. Time magazine had circulation of 220,000 in 1929. Kodak cameras. Bell telephone. National Cash Register. International Business Machines.

American Express. Esso. Phillips 66 gas stations. Peabody Coal Company.

Kotex. Kleenex. Toilet papers and paper towels became necessities. Cellophane. John Deere. International Harvester.

Northern Pacific. Chicago, Burlington & Quincy Railroad Company. Great Northern. Missouri Pacific. Norfolk & Western. Atchison, Topeka and Santa Fe. Southern Pacific. Union Pacific. Illinois Central.

Steamboat Willie. A & W Root Beer. MGM. Doubleday. Harcourt, Brace & Company. James Thurber. E. B. White. Robert Benchley. Harper & Brothers. McGraw-Hill Book Company.

Chesterfields, "Blow some my way." "I'd walk a mile for a camel." Prohibition.

3M masking tapes. Hallmark cards. Wrigley's Spearmint gum.

# Crime

## ABOUT ARRESTS

The idea of "arrest" implies a hierarchy of authority and function: were there only one person, then that person would be policeman, judge, jury, jailer, and executioner all in one, and the idea of arrest would be pointless.

Every arrest will vary, but commonly each arrest will present one or more hypotheses or assumptions on the part of the arresting officer.

1. The officer doesn't know what the adventurers are doing, but it looks suspicious: preventive arrest.
2. They committed a crime of property.
3. They committed a crime of violence.
4. They outraged local custom and public decency.
5. The authorities wish to confiscate something (or everything) that the adventurers own.
6. Information that the adventurers have may be embarrassing, compromising, etc., to individuals, a government, a group, a nation, etc.
7. The adventurers are obviously insane and society must be protected against them.
8. The adventurers are dangerous in some manner to the authorities.
9. The adventurers are in danger, and need the protection the jail offers.

Any policeman making an arrest additionally must weigh factors such as what he individually stands to gain or to lose by making the arrest, the apparent status and probable wealth of the adventurers, the visibility of the offense, the importance of the offense, and the apparent danger to the way things are as posed by the adventurers. The referee should make clear the motivations of the arresting officer, because it will determine the players' course of action.

### PROCEDURES OF ARREST AND PROSECUTION

1. The arresting officer will identify himself or his authority, so that the adventurers know he has the backing of law or society. Depending on the custom or the strength of the evidence, the arresting officer may or may not bother to tell the adventurers why they are being arrested.

2. If the adventurers resist, the police will use the force appropriate to make the adventurers conform to the needs of the state.

3. If the adventurers go quietly, they will be disarmed and secured in some manner, then will be taken to some station, court, or superior official so that the arresting officer can transfer the responsibility of his prisoners and record the fact of their apprehension.

4. The adventurers will be questioned en route and at the station, and may be required to make a statement.

5. Even after being jailed, the adventurers may be unable to learn the reason for their arrest. They may or may not be allowed communication with the outside. The fact of their arrest may be kept secret. They may be kept imprisoned separately, rather than as a group. They may be tortured for information.

6. The authorities may or may not allow a trial. They may refuse to allow witnesses favorable to the adventurers.

7. If found guilty the penalty may reflect the crime, or it may reflect the danger the adventurers pose to an individual, a group, or the state.

8. Sentences may split up the adventurers, or otherwise be designed to force them to lose cohesiveness. Adventurers who cooperate with corrupt authorities may not live long, because they then become evidence of that corruption.

# SOME HISTORY

On January 16, 1920, the 18th Amendment to the U.S. constitution went into effect, beginning what quickly became known as Prohibition, a period lasting until the Roosevelt administration in the 1930's. Though the Amendment stopped legal production of alcoholic beverages in the United States and its territories, it did not halt the demand for liquor, and from that demand rose a number of criminal syndicates determined (for a price) to quench the thirst of Americans.

Small illegal distilleries produced liquor for the heartland of the nation, but poisonings occurred often enough from such homegrown spirits that both safety and prestige lay in securing good liquor produced in other countries. Thus began the bootlegging era.

Much of the bootlegged liquor came from British vessels anchored outside the formal three-mile limit which was then the area of oceanic control claimed and enforced by the United States. Motor boats smuggled the contraband to various points along the east coast of the nation. Trucks from Canada and rum-runners from the Caribbean also provided the bonded quality booze that brought the high prices and the highest profits. The syndicates sold the liquor (either straight or cut) to independent distributors who either sold it directly to retail customers or to 'speakeasies,' illegal bars whose only advertisement was word-of-mouth.

In general, the syndicates transferred, rather than produced, and therefore did not have the normal operating requirements of industries, such as raw materials, capital investment for plants, and so on. However the necessities of extensive communication and transportation networks stimulated cooperation between syndicates in various regions of the nation. As a practical matter, the Volstead act turned gangs into corporations, and immeasurably aided the growth of organized crime.

With the enormous profits from bootlegging, the syndicates were able to capitalize and regularize illegal activities of every sort—bookmaking, gambling, the fencing of stolen property, prostitution, control of unions, loan-sharking, the numbers racket, narcotics, 'protection,' and so on. In every case where well-intentioned legislation attempted to stifle personal demands of citizens, organized crime was equipped and prepared to fill the demand at a much higher price. The vastness of the various markets and the lengthy existence of organized crime

indicates a total cash outlay for all these illegal activities of hundreds of billions of dollars.

The largest and most successful syndicate was the 'Big Seven,' which included Waxey Gordon, Charles (Lucky) Luciano, Bugsy Seigal, and Frank Costello, and which controlled the east coast.

In the New York area, Guiseppe (Big Boss) Masseria controlled vice in Brooklyn and Manhattan. Dutch Schultz ran the bootlegging and numbers rackets. Lepke Buchalter and Gurrah Shapiro controlled narcotics and extortion as well as engaging in strike-breaking and labor-extorting enterprises.

In Chicago, the Shelton Gang headed bootlegging and gambling. Al Capone watched over almost every significant criminal action. The competition included Dion (Deany) O'Bannion, Hymie Weiss, and George (Bugs) Moran. During the decade Chicago knew 629 unsolved gangland murders (and a total of 5000 apparently non-gang-related killings). Most famous of the episodes was the St. Valentine's Day Massacre on 14 February, 1928, when seven underlings of Bugs Moran's North Siders were shot to death in a Chicago warehouse by agents of Al Capone.

In Detroit, the Purple Gang with Eddie Fletcher controlled bootlegging. The Licavoli Gang distributed the liquor and controlled extortion.

In a different vein, the early 1920's also saw the return of and the heightened influence of the Ku Klux Klan, especially in the Ohio river valley, the South, and in portions of Oregon and California. The Klan, however, never succeeded in finding firm financial backing, and its history is more one of moments of terror than of omnipresent control. A Klan rally of 100,000 people was held in Kokomo, IN, in July of 1923.

With the economic depression signalled by the stock market crash of October 24, 1929, organized crime began to take a backseat in the popular press to the exploits of individual bank robbers like Pretty Boy Floyd, Ma Barker, Bonnie and Clyde, and John Dillinger. Carefully-laid federal indictments for tax-evasion also made visibility a distinct hazard for organized criminals, and more and more the swaggering anti-heroes of the 1920's became conservative, well-dressed, and inconspicuous men without public names.

# BRIBERY

Officials are most likely to be bribable if they are in small towns and rural areas (where pay is low and the consequences possible from a bribe are well-known) or in large cities (where the bribee constantly contrasts his expectations with the affluence around him). Referees might make the skill of bribery a function of the briber's CHA or POW.

Calculate bribe rates in terms of a day's wages for the bribed official, and accept bribes along these lines: minor matters might cost 1-4 hours pay as a bribe; major matters will cost a day to a month or more, depending on the seriousness of the matter. The higher the level of the bribed official, the more money he or she will cost. Use the same rate basis for bribes in foreign lands.

Rates may also differ with the degree of the offense in the eyes of the bribee. A county sheriff who is glad to see the old Barnsworth place burn because neighbor kids kept getting hurt there will want less (or nothing at all) from those who burnt it; the same sheriff will react differently when the only hotel in Ponyville goes up in flames, along with four odd but peaceable-seeming residents whom some firebug freaks from Chicago claim were vampires.

If player-characters over-bribe, the bribee will become alarmed and think that perhaps he doesn't understand the situation, and refuse the

bribe. Alternatively, the bribee may think the PCs are fools, and hold out for twice as many dollars. Player-characters should hit the right range, or suffer the consequences.

<i>Bribe to Rural Policeman</i>	—	\$2.00 misdemeanor, etc.
	—	5.00 more serious matter
	—	100.00 capital offense
<i>Bribe to Urban Policeman</i>	—	4.00 misdemeanor, etc.
	—	10.00 more serious matter
	—	250.00 capital offense
<i>Bribe to Government Official</i> ( <i>police chief, tax assessor,</i> <i>district attorney, sheriff,</i> <i>smallish-town mayor, etc.</i> )	—	\$50.00 small matter
	—	200.00 more serious matter
	—	1000.00 capital offense

If the player-characters are trying to bribe their way out of a serious situation, then they may need to bribe several different people or even a whole layer of civil servants.

# On Cultists

Humans often worship the alien entities of the Lovecraft myths. These humans are usually primitive, sometimes mutated, and always are a bit deranged. Lovecraft rarely emphasizes them, yet often suggests them; this essay will guide Keepers in entity worship and entity worshippers.

Worship may take any of several forms, but in general the worshippers admit their inferiority to the entities they worship, sacrifice something to the entities to show their respect and submission, and occasionally receive something in return. There are usually presiding

officials, commonly called priests, and there are always sacred ceremonies and rituals which are followed during worship. These forms are followed by the cultists of the Lovecraft myths as well, and these points are detailed in the following section.

The mortal cultists are most often the enemies which the players will encounter. There are several reasons for this, primarily the fact that they are the most common and most visible part of the alien presence. Also, these cultists are usually the holders of some knowledge,

## Other Occupations

Listed here are some alternate occupations which investigators and keepers may wish to try. Other occupations not listed can be easily extrapolated by comparing them to those listed below and those given in the rulesbook.

### ANARCHIST

Camouflage  
Fast Talk  
Hide  
Library Use  
Oratory  
Psychology  
Read/Write Other Language  
Sneak

### GANGSTER

Bargain  
Climb  
Credit Rating  
Drive Automobile  
Fast Talk  
Jump  
Law  
Listen  
Spot Hidden  
Handgun Attack  
Knife Attack

### MISSIONARY

Accounting  
Bargain  
Credit Rating  
Diagnose Disease  
First Aid  
Oratory  
Read/Write Other Language  
Sing  
Speak Other Language  
Treat Disease

### PROFESSIONAL ATHLETE

Climb  
Credit Rating  
Dodge  
Jump  
Psychology  
Ride  
Swim  
Throw

### HOBO

Bargain  
Climb  
Fast Talk  
First Aid  
Hide  
Listen  
Spot Hidden  
Sneak

### POLITICIAN

Accounting  
Bargain  
Credit Rating  
Debate  
Fast Talk  
History  
Law  
Oratory  
Psychology

### FARMER

Bargain  
Botany  
First Aid  
Listen  
Mechanical Repair  
Operate Heavy Machinery  
Spot Hidden  
Zoology

### POLICEMAN

Drive Automobile  
Fast Talk  
First Aid  
Hide  
Law  
Listen  
Spot Hidden  
Sneak  
Handgun Attack  
Nightstick Attack and Parry

### SOLDIER

Camouflage  
Climb  
Drive Automobile  
Electrical Repair  
First Aid  
Hide  
Listen  
Operate Heavy Machinery  
Spot Hidden  
Sneak  
Rifle Attack

magical spells (especially of protection), or magical items which are valuable to the player characters: Finally, any PCs who have gained knowledge of what they are up against will try to keep as far away from the main entities as possible, but will continue relentlessly to wage war against them. This means the destruction of the deranged worshippers wherever possible, either through the theft of their sacred or protective items or through the actual death of the individuals. It is also most likely that the worshipped entities will use their mortal pawns to attempt to destroy the intrusive player-characters.

### GENERAL NOTES ON THE CULTS

The cults of the alien 'gods' or of their inferior races all have certain facets in common.

They are led by a priest. This priest may have other assistants with powers similar, though generally weaker or less developed, than his. The priests will know, perhaps, minor protective spells created by the Keeper and a Summon or two. The Summon will be for the god worshipped, and perhaps also for calling the right kind of race that serves the god. The priests might know the spells to Dispel such creatures, as well.

Priests also may be a good source for minor treasures and magical items which could be useful to player-characters in the future. They might have magical books or scrolls for their spells, or might have amulets of protection or communication. Whatever is decided, a priest always should have the force needed to cow a congregation and lead the ceremonies.

Priests are, almost by definition, permanently insane. They have devoted themselves to the worship of the 'god' and have viewed it many times, losing SAN each viewing. By the time they become effective priests, they are quite mad.

It is possible that the priests maintain the ability to act, rather than go into one of the states designated on the Insanity Table, because they voluntarily began the worship of the god. Notice that this does not protect their SAN, it only makes them into slaves of the entity worshipped.

Initiates or worshippers of the cult will also be deranged by having viewed the ceremonies and manifestations, but they will not have lost all mental faculties through voluntary subjugation to the cult.

If any player-characters decide to join the cult, they of course will go permanently insane when their SAN reaches zero. No priest will trust a recent convert with any valuable information, and probably will wait until the PC's permanent insanity proves his eternal devotion.

Thus you can see that the common band of worshippers are also quite insane. This is characterized by their fanatical devotion to their religion. They are also likely to be as frightened of the priests and leaders as they are of the gods.

### PRIMITIVE CULTS

Many stories present primitive peoples as having been transfixed by these creatures or entities in ages past, continuing their unholy worship in the dark corners of the worlds. This is quite likely since any civilized peoples or organized religion would do everything possible to suppress such insanity.

Remember that it would be difficult to penetrate such uncivilized regions, and that hostile inhabitants could make it even more difficult. Not all natives may be hostile. Most of them may despise the cultists as much as do the player-characters. The natives may appeal to the players for assistance and offer aid in return.

Keepers and players should not infer that humans who putatively are uncivilized also are necessarily unsophisticated about the way of life their land demands. It takes brains, skill, and guts to survive in a wild environment. Any common farmer in his own realm is more likely to be tougher and better able to cope than the best-educated and best-equipped outsider.

### NON-HUMAN WORSHIPPERS

In some places there are cults consisting of non-human or mutated human creatures. These monsters always are kept well-hidden and their ceremonies are kept a great secret.

Even so, their priests will be quite insane, their ceremonies wild and frightening, and the worshippers fanatical beyond all reason.

### SACRIFICES

It is quite likely that the cults will sacrifice living humans to their outrageous demon gods. This provides the motivation for hundreds of pulp stories.

The sacrificial ceremonies may have the victim be any random human. It may be someone picked for certain characteristics, whether it is blonde hair or a true devotion to the god being worshipped. The rites will always be a full ceremony requiring all the participants to generate enough frenzied and insane energy to summon the monster.

The victim may be thrown into the ring of Summoning, given to a servant who flies away with the prize, or be ripped to shreds by the worshippers. Or it may be simply that the servants of the god will appear to the Summons and go through and destroy random members of the congregation.

Other items of sacrifice are always possible, but unlikely to appeal to insane gods without being accompanied by senseless brutality and meaningless loss. Such creatures inevitably deserve the destruction which the players will attempt to deliver.

### BENEFITS TO THE WORSHIPPERS

The unimaginable benefits derived from worshipping insane beliefs are left to the perverted minds of the worshippers, but we can imagine that they believe themselves somehow 'chosen' by the god for some greater glory.

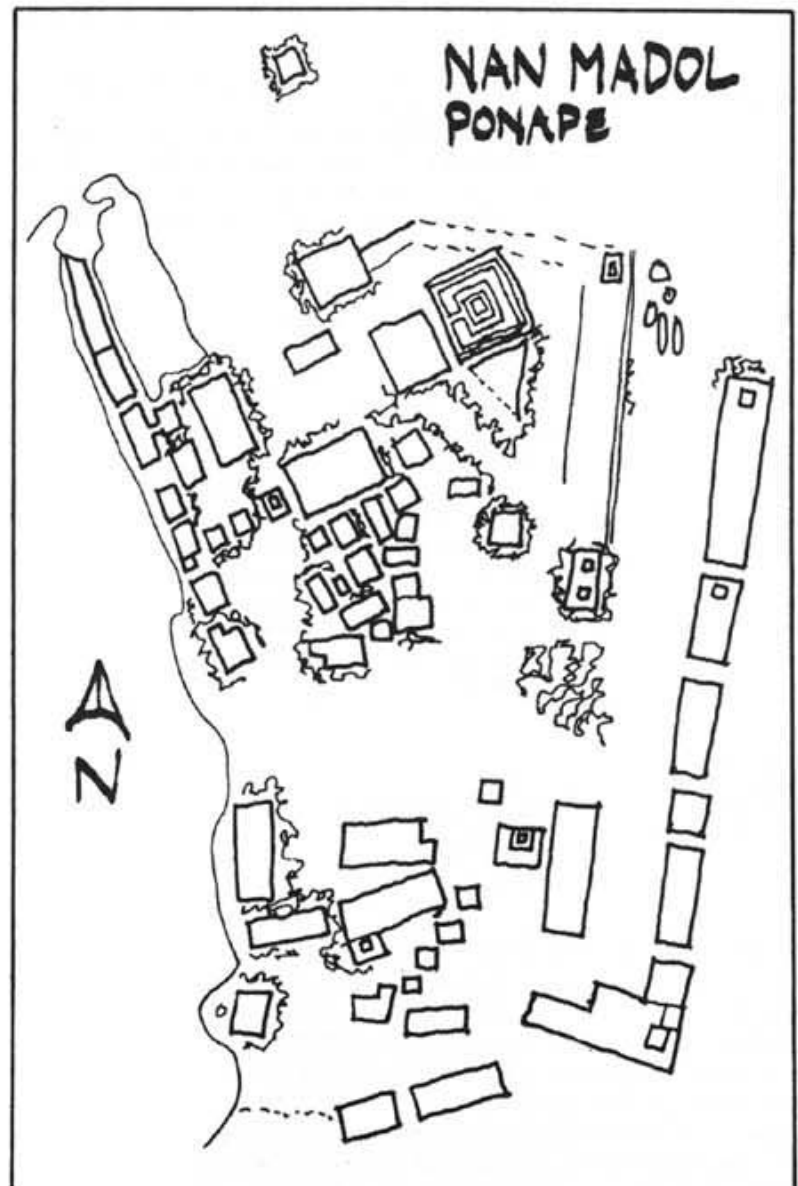

*Nan Madol, ca. 900 A.D. or earlier, consists of about 175 acres of artificial islands (only the main ones are shown on the map) which include burial places, ceremonial platforms, and eel- and turtle-holding pens. The islands, mostly covered by nearly impenetrable mangroves, are made of natural basalt columns piled in alternating rows, like logs. The site is located just off the eastern tip of Ponape, in the Caroline Islands of the Pacific.*

It is likely that worshippers know all too well the real dangers of the monster and receive some protection, limited or full, for their support. The priest will always benefit most, his assistants derive the next greater benefits, and the worshippers get the least.

#### COSTS OF WORSHIP

For whatever benefits they receive, or think they receive, the worshippers of these foul entities all suffer certain results for their misguided piety.

All worshippers are, by definition, insane after a few services. As such they lose all individual identity, and then come under the control of the referee.

# Nautical Skills

#### Boating

The Boating skill provides a character with the techniques of small boats. Small boats include rafts, canoes, rowboats, and small motorboats. It does not include craft powered by sails (see Sailing, below). If a craft is controlled by more than one person, as a canoe might be, then each character must attempt to make successful Boating skill rolls, unless there is a commander who makes his Shiphandling roll instead.

#### Sailing

The Sailing skill determine success or failure in moving a boat or ship using sails. The skill includes all sailing craft of any size. In large ships which require many people to handle the sails, every crewmember must make a Sailing roll, unless the individual in command makes his Shiphandling roll.

#### Shiphandling

Shiphandlers know how to run a ship or boat, making the most efficient use of craft and crew. The skill is usable only by the commander, and is rolled only when the gamemaster calls for it. If you want to get the best sailing speed or row the most efficiently or take proper advantage of the tides, your Shiphandling skill can help. Differentiate it generally from Boating below by recognizing that Shiphandling is concerned with the strategies and tactics for conduct in fresh and salt water. Differentiate it from the Sailing skill by recognizing that Sailing concerns only the techniques of handling vessels with sails. The Shiphandling skill will always take precedence over either Boating or Sailing, and is a true command-level skill.

They are generally quite fanatical, capable of great actions when in a frenzy but quite unlikely to be capable of intelligent actions, especially after or during their profane services or when spurred on by their priest or god.

They become the pawns of manipulative priests or alien gods who have no regard for the worshippers' beliefs, desires, or intentions.

In general, they lead sub-human lives of vile motive and of desperate meaninglessness. As reward for their lives and souls, worshippers receive small tokens from their priests and god; such rewards are illusory compared to the cost. The constant anger of the worshippers comes from their unconscious realization of the cheat—and their inability to do anything about it.

*EXAMPLE: Ben, Jerry, and Marge are sailing on a pleasant Sunday afternoon, between adventures. Their little craft is named the Myra. Foolishly, Ben mentions the Name Which Should Not Ever Even Be Whispered, a new deity in their campaign. Within minutes a storm is brewing, and a chill northern wind whips about their frail sailboat.*

*Ben, experienced in Sailing from his yachting days, makes his Sailing roll and the boat does what is best for the situation. For the moment everyone is safe, but the gamemaster tells them it will take eight more successful Sailing rolls to reach shore. The clouds are black, and there is ice on Ben's well-trimmed moustache as he handles lines and tiller. Then Ben's player misses the Sailing roll with a 98, and the gamemaster rules that something bad happened because the roll was so high. The mast has snapped, he says, and the Myra is awash.*

*Fortunately, they have some oars! Since there is no longer a mast, the Myra is no longer a sailing craft. All three aboard grab oars and frantically try to make their Boating rolls. Jerry, who is smart but weak, is only 15% and fails continually. Each failure means that the craft is no closer to shore.*

*At last Marge reveals that she had been raised by Trobriand islanders many years before, and has a good Shiphandling skill. Ignoring the protests of macho Ben, she orders Jerry to dump mast and sail, then counts time with a rowing chant and makes her die roll easily. She makes it again, six times in a row, and the storm lessens. At last the Myra limps to the dock, ruined and ice-covered, to the astonishment of gentlemen in high hats with ladies on their arms, the whoops of picnicking children, and the whispers of their parents sipping tea and staring up from their lunches, all of them wondering what could have happened to that ugly boat on such a calm and sunny day.*

# Sages

Sages are known by many names: philosopher, guru, wise man (or wise woman), and so on. In *Call of Cthulhu*, the name indicates an optional NPC character type intended to give extra Keeper flexibility during a campaign. Sages have high Psychoanalyze and First Aid, know their locales intimately, have considerable Occult skill, and even may have some Cthulhu Mythos. As an NPC, the sage may be used by the Keeper to provide limited help for the player-characters, to supply the PCs with information, or even act as a sympathetic character whose death proves the evil villainy of the death-doer. Sages sometimes threaten PCs, as related below.

#### CHARACTERISTICS OF A SAGE

A sage is a man or woman who has evolved a way of life in harmony with the universe. Sages refuse involvement with worldly bustle, prefer-

ring to study their own motives and the meanings implicit in the world. This understanding leads them to deeper levels of perception. Though sages are very realistic, most people who encounter them perceive sages as mystics and magicians.

All cultures at all times produce sages. Typically thought of as leading hermit-like existences, sages actually work at every occupation not demanding duplicity and misrepresentation. A sage can be a nurse, carpenter, or scientist, but can not be an advertising copywriter or a politician. Since sages need time to recognize the truth, they normally are more than 50 years old. Sages look and dress normally. The Investigator who meets a sage will notice keenness, a sense of humor, and warmth. PCs may notice unusual tolerance and intolerances in a sage.

Players should not be told of the existence of sages. Sages never create organizations or committees. Sages are often found near libraries with extensive Occult holdings, there pursuing their spiritual progress.

**STUDYING WITH A SAGE**

If, during the course of play, a sage demonstrates his unusual powers, player-characters may ask to study with him. Though counseling that such study will take years, the sage will accept as a student any who then ask, who also can roll their POW x 5 or less on D100. Later requests will not be honored.

Every six months of study with a sage restores 1D20 points of SAN and adds 1D10 points to the Investigators Occult skill. If the Investigator's Occult roll happens to be 9 or 10 (9-0), the Investigator will further receive 1D6 points of Cthulhu Mythos (added Cthulhu Mythos will decrease the Investigator's maximum SAN by an equal amount).

Any Investigator who studies with a sage runs the risk of being converted to the path of the sage, thereby forgetting his fellow Investigators and his potentially world-saving mission. The player-character cannot leave the sage until his POW has overcome the sage's POW on a resistance table roll. The PC gets two chances to beat the sage, at successive six game-month periods. Failure means that the PC is unalterably on the way to sage-dom. The character becomes an NPC, now in the possession of the Keeper.

**WALT WHITMAN KOVACS**, carpenter, age 58. Lives in Pamansett, Long Island. Specialist in stairs and cupolas. Citizen of U.S.A. Has grade school formal education.

**STR 14 CON 15 SIZ 12** Parry 75% with any object; will not use offensive weapons.  
**INT 15 POW 18 DEX 14**  
**CHA 13 EDU 16 SAN 90**

**SPELLS:** no spells, but makes hypnotic pass which casts his POW vs. the POW of any servitor race on the resistance table. Only good against one monster per melee round, and not good unless the being can see or otherwise detect the hypnotic pass.

**SKILLS** - [Knowledge] Read/Write English 90%, Read/Write Latin 60%, Read/Write Sanskrit 30%, Accounting 15%, Anthropology 35%, Archaeology 25%, Astronomy 25%, Botany 75%, Chemistry 10%, Cthulhu Mythos 05%, First Aid 60%, Geology 10%, History 45%, Law 10%, Library Use 60%, Linguist 25%, Occult 45%, Pharmacology 30%, Treat Disease 30%, Treat Poison 30%, Water Divining 80%, Weather Forecasting 70%, Zoology 15%; [Perception] Diagnose Disease 30%, Listen 80%, Psychology 80%, Spot Hidden Object 25%, Track 15% [Manipulation] Drive Auto 25%, Electrical Repair 10%, Make Toys 90%, Mechanical Repair 20%, Operate Heavy Machine 10%, Pilot Aircraft 00%; [Stealth] Camouflage 70%, Hide 55%, Move Quietly 75%, Pick Pocket 10%; [Communication] Bargain 95%, Calm Mammals 85%, Commune with Universe 95%, Credit Rating 25%, Debate 60%, Fast Talk 75%, Green Thumb 80%, Oratory 50%, Psychoanalyze 90%, Sing 15%, Whistle 80%; [Agility] Climb 45%, Dodge 70%, Jump 35%, Ride 20%, Swim 30%, Throw 45%.

**EQUIPMENT:** carpenter's tools, fishing pole (no hooks), small microscope, spyglass, barometer.

**MONEY:** \$3.78 in cash, \$670 in savings bank.

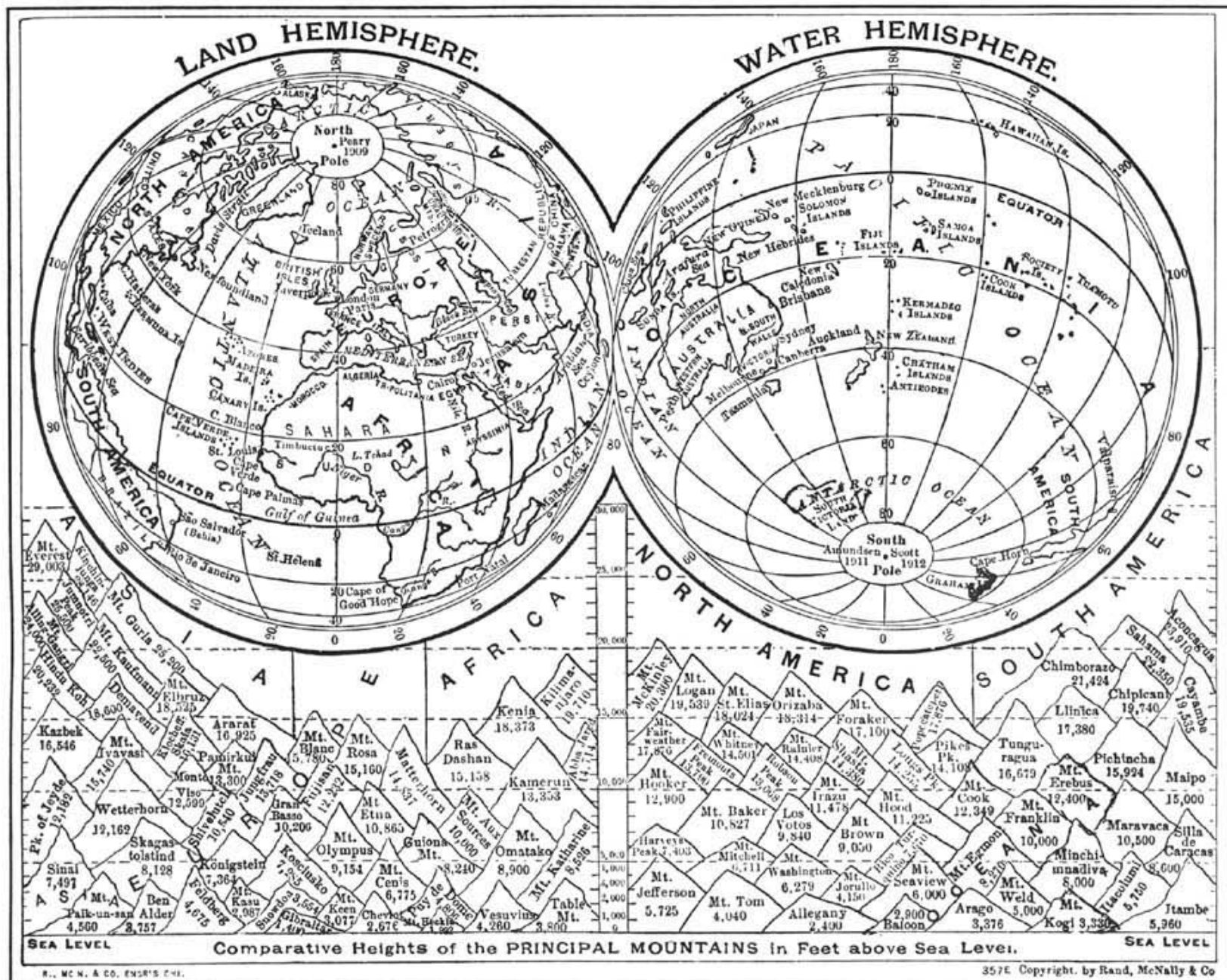

# RAIL LINES CA. 1920

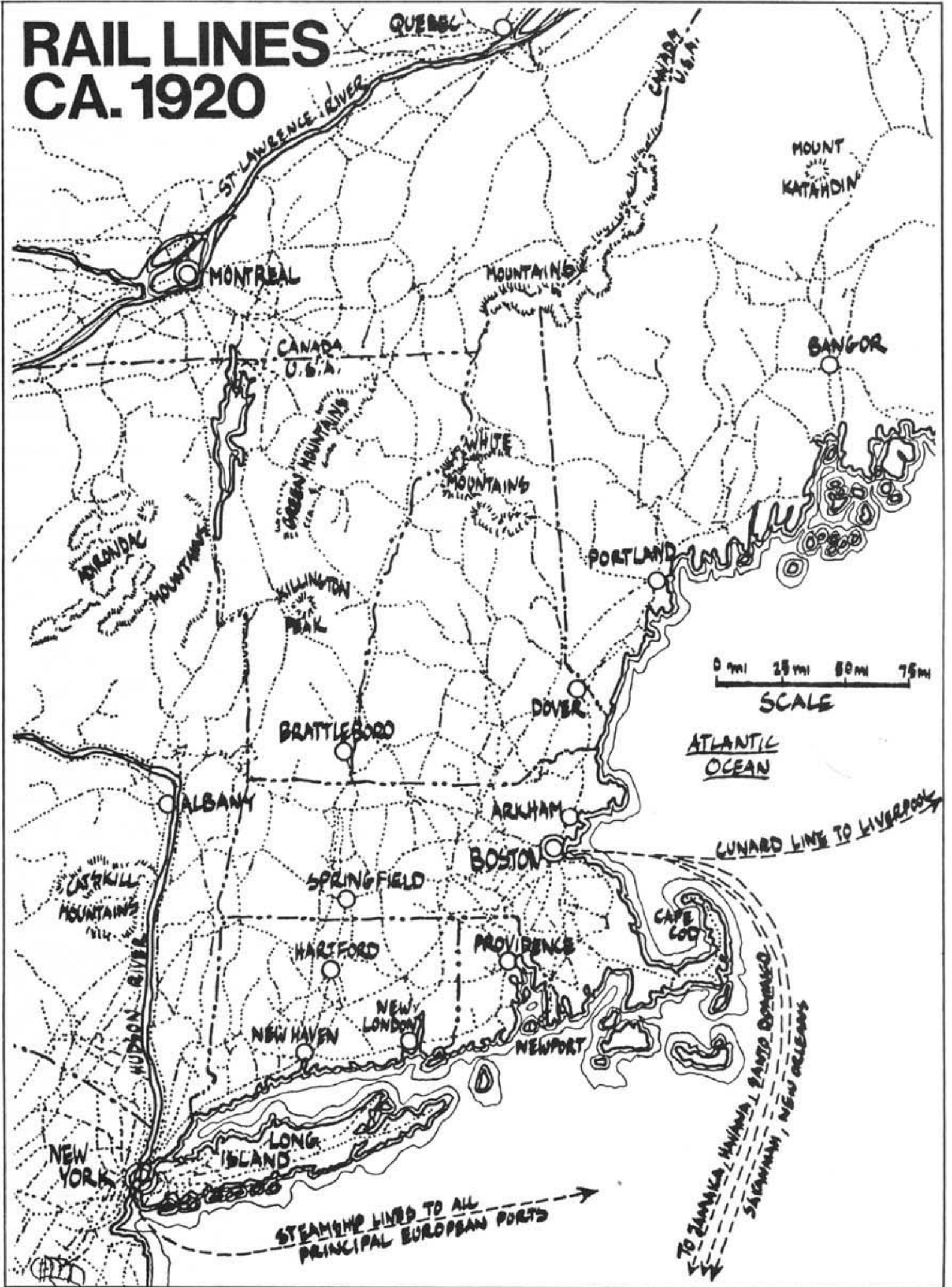

# IFE, NIGERIA

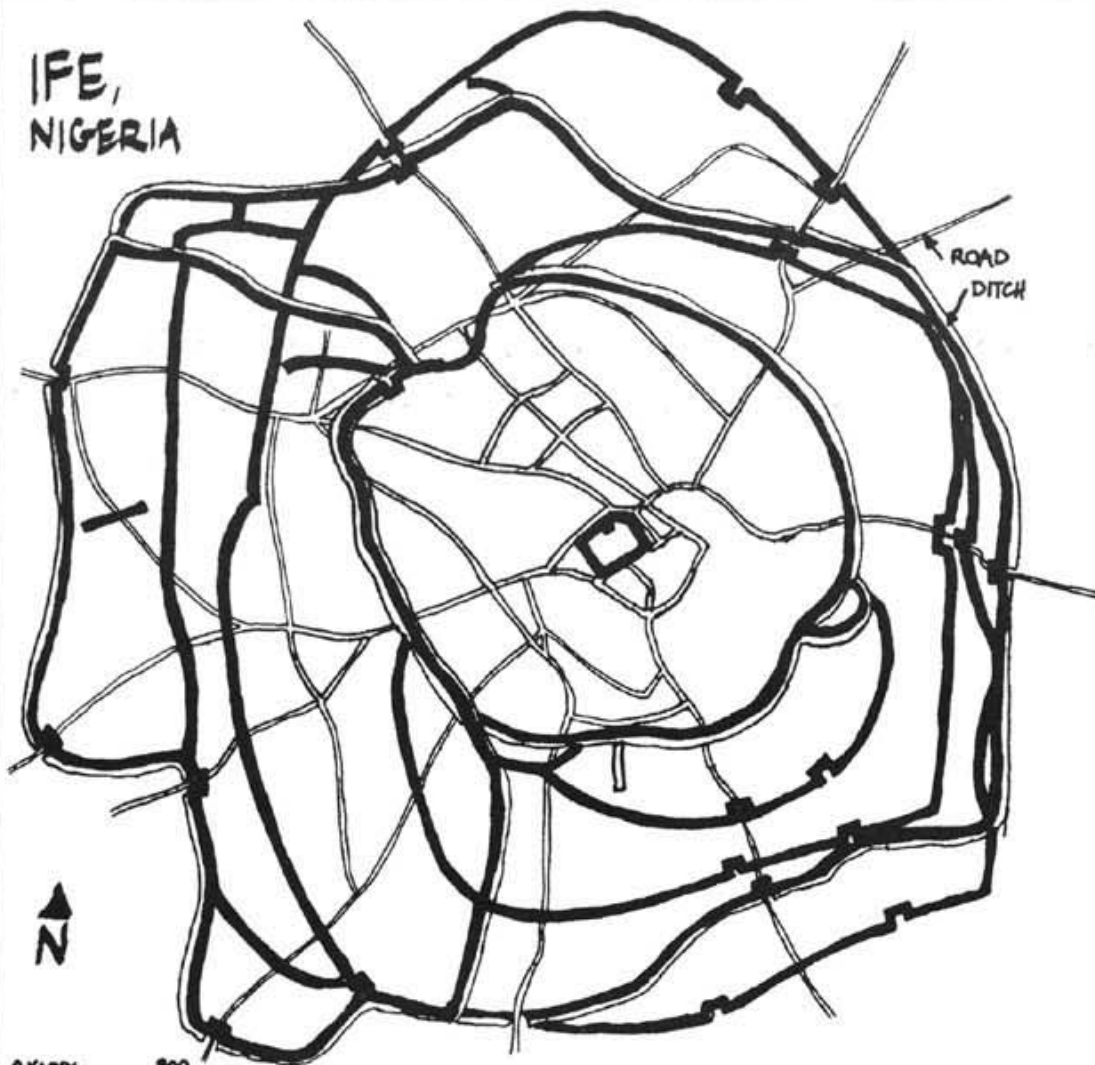

*IFE, in Nigeria, is the holy city of the Yoruba, and the medieval producer of some of the most famous African sculpture, in both terracotta and brass. The heavy black lines are town walls from various periods, broken for roads or obliterated for other construction, or still standing. Upright walls will be a minimum of two men tall. The indentations in the walls guard gates.*

0 YARDS 800  
0 METERS 800

*SCARA BRAE was excavated by V. Gordon Childe between 1927-1930. It is a hamlet from about 2000 B.C.; in its finest phase the houses were built of drystone and a slab-covered 'main street' ran between the dwellings. There is a central hearth in each building. The roofing is unknown.*



# SCARA BRAE, ORKNEY ISLANDS

0 FEET 15  
0 METERS 5



# Railway Coaches

*This PULLMAN COMPARTMENT SLEEPING AND PARLOR CAR is one of the many arrangements produced by that company. This one features seven private state rooms connectable by interior doors, which could be kept locked or unlocked depending upon the size of the party of travellers and their desire for privacy; notice that adventurers could move down the coach either through the passageway or through the connecting rooms. The beds unfolded, and in the daytime were small settees. At night, with the beds made up, there was barely enough room to open the state room door. The coach could be entered by outside doors at either side of either coach end, as well as from adjoining cars.*

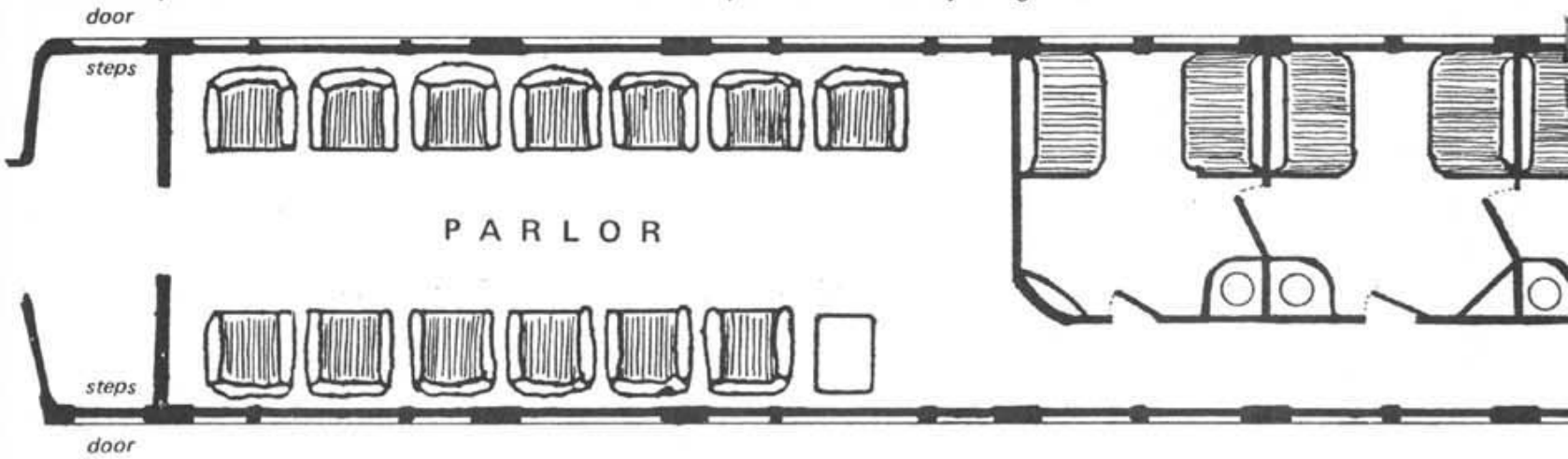

*Here is a sample PRIVATE RAILWAY CAR. Other such cars had several smaller state rooms, or perhaps a more central location for the kitchen, giving added separation and privacy to the ends of the car. This car is notable for the generosity of its few rooms, and was built for one man or one family. Entrances again are at either end, from either side. The private car was not built so that foot traffic on the train passed through it; entrance from the main train is possible only by leaping the*

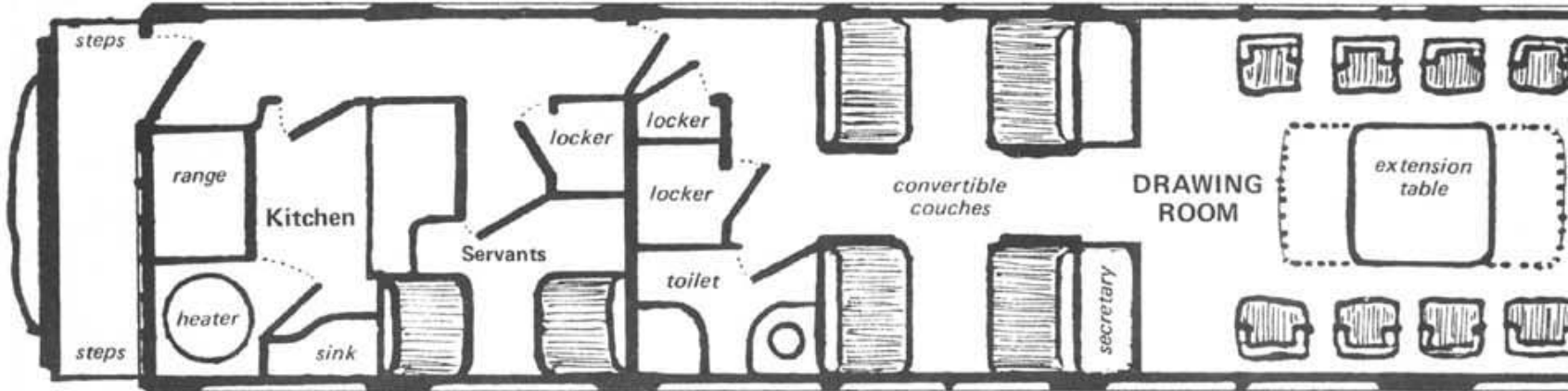

*These EUROPEAN-STYLE CARS were built at about the turn of the century, for service on British railroads. The obvious difference between U. S. and European coaches is that the European coach has compartments which are entered directly from the station platform, an advantage in the ease of movement. The special third-class ladies' section allowed poor but virtuous women to segregate themselves from the potentially rowdy and rude behavior of males—their portion of the train*

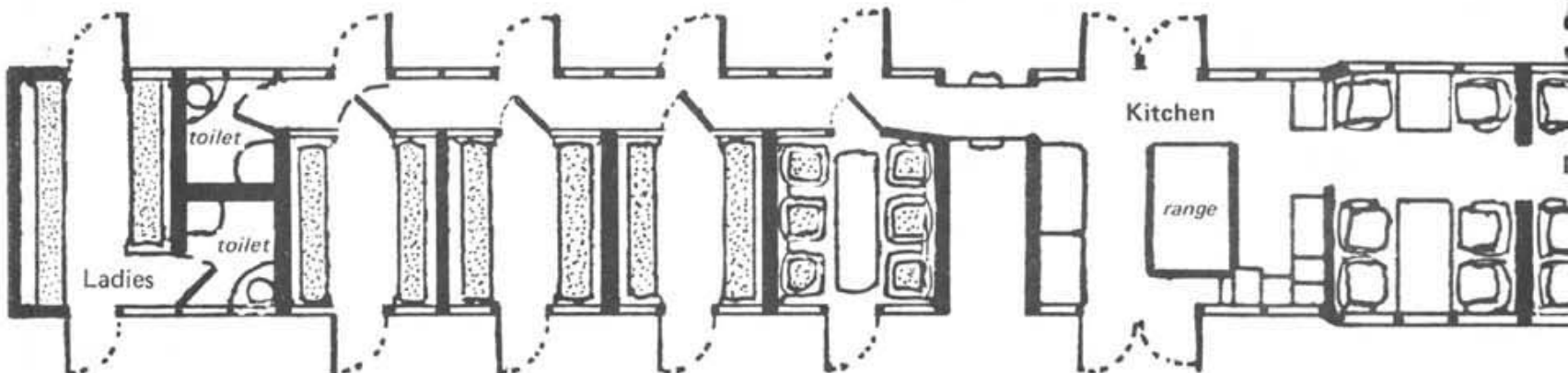

*Third Class*

These floorplans can be useful for 15mm and 25mm figures. The bases for most 25mm figures may be large for the space, though the space taken up by a figure itself will be nearly to scale. Only 15mm figures can be used with the last diagram, since its scale is somewhat larger, in order to fit on these two pages. The PULLMAN COMPARTMENT SLEEPING AND PARLOR CAR and the PRIVATE CAR are both about seventy feet long, with an interior floor width of slightly less than ten feet. The EUROPEAN-STYLE CARS diagram is actually of three cars linked together, in a configuration used around the turn of the century. The scale of this last diagram is about 20% larger than the other two.

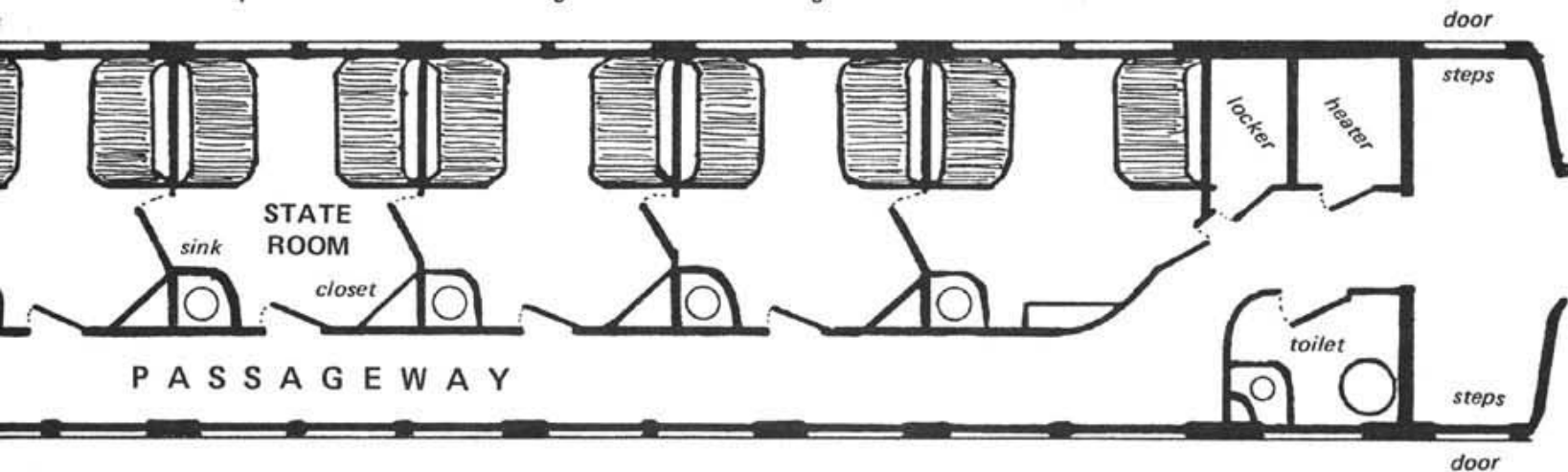

coupling holding the private car to the train, at the kitchen end of the car. Private cars were always attached to the ends of trains, and the Observation Room would always look out over the vista which had just been passed. This car has available three unfoldable doubles and three singles, enough for an entire party of adventurers. Private cars could be attached either to regularly-running trains, or to a rented locomotive, though passage would have to be cleared for such special trains.

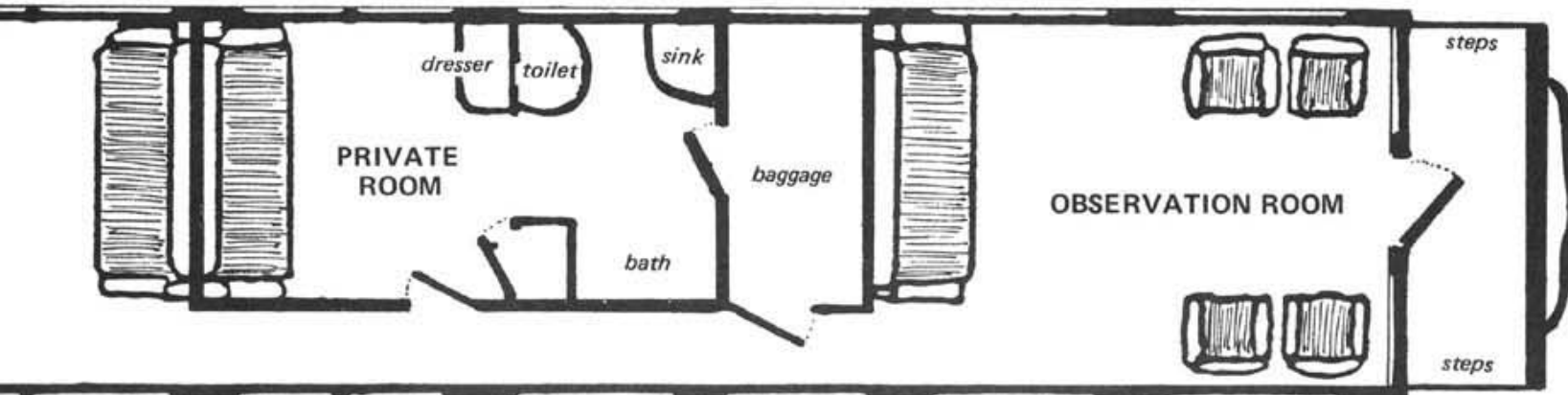

could be entered only while the train was halted. Notice also how the kitchen separated third-class from the monied part of the train, forbidding interior movement. Since compartments were entered directly from the platform, there was no need for full movement down the length of the train; ticket-takers would wait for the next station to enter the next series of cars.

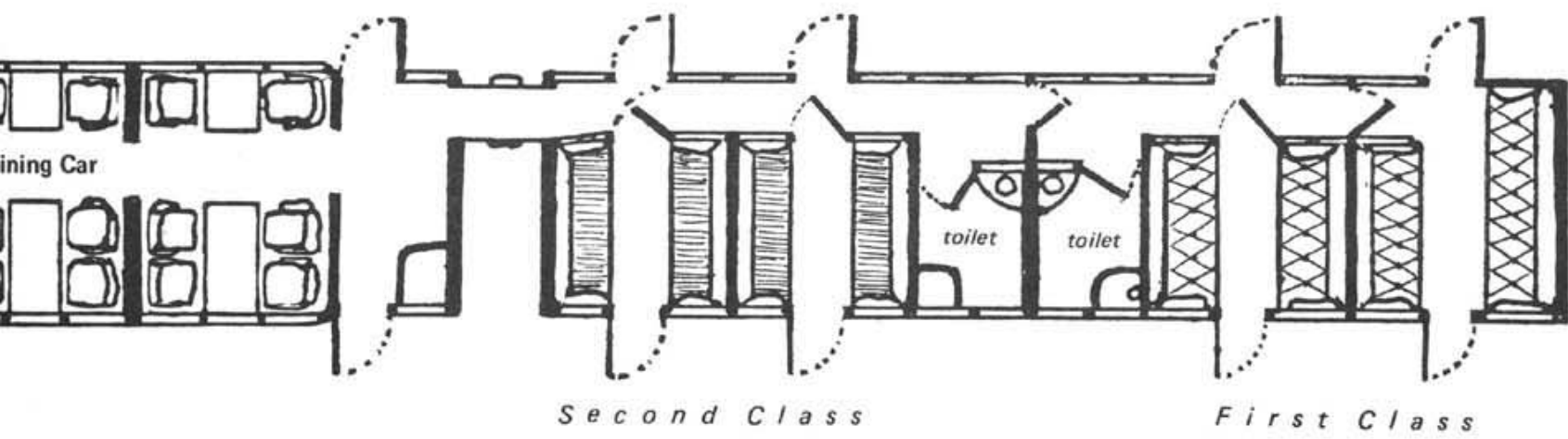

# Travel

## TRANSPORT SPEEDS

Throughout the 19th century and into the 20th century, the steam engine steadily decreased the time needed to travel from one place to another. Up to and through the Great War, the keys to travel were the steamship and the railroad.

World War One greatly advanced the young inventions of the automobile and the airplane, and they were in the forefront of travel after 1950—but in the 1920's their day had not quite yet come, and it was not to them that people looked for speed, reliability, or comfort.

Below are sample transportation times for all the common carriers, as well as some speed records good till 1930 for your education and delectation. The travel times and speeds listed are simply convenient averages. Your own historical research will reveal more exact figures for particular areas, years, and vehicles.

### Air Speeds and Ranges

Normal single-engine fixed-wing aircraft — 300-500 miles, with a ground speed of 120mph.

Normal double-engine fixed wing aircraft — 500-800 miles, with a ground speed of 90mph.

Large dirigible or zeppelin — 1000 miles, with an air speed of 5-10 knots.

Longer ranges are available with special preparation.

### Ship Speeds

The following table gives the average ability of a type of ship to follow a schedule, what its average speed is, and what the usual price for passage is. Most prices are given in cost per 100 miles and cost per 1000 miles. For a short run, use the former column; for a long run, such as around the world, use the latter column.

Type	On Time?	Speed	Cost Per 100 Miles	Cost Per 1000 Miles
Tramp	+/- 30 days	10 knts	\$ 5.00	\$15.00
Freighter	+/- 5 days	14 knts	10.00	30.00
Liner	+/- 12 hrs	25 knts	20.00	60.00*
Ferry	+/- 15 min	5 knts	.15 first mile, .05 per miles thereafter	

\* First class accommodations on the liner are available at triple prices. Miles traveled per 8 hr. day: Tramp — approx. 90 mi.; Freighter — approx. 130 mi.; Liner — approx. 230 mi.; Ferry — approx. 45 mi.

### Automobile Speeds

The average long-distance auto speed over 1920's roads in a 1920's car was 15 MPH over eight hours, or 120 miles per day. In certain well-paved corridors, of course, such as between Boston and Philadelphia, the average speed could be higher.

### Railroad Speeds

The average long-distance rail speed was 35mph for 24 hours, or 840 miles per day. Here are some representative travel times for regularly scheduled runs:

Run	Time
San Francisco/Oakland-Omaha-Chicago	70 hours
New Orleans-Los Angeles	60 hours
San Francisco-New Orleans	73 hours

### Record Train Speeds, by 1930

20th Century Ltd., Elkhart IN/Toledo OH, 74.26mph.  
NY Central Special, between Granite City IL and Berea OH, 67.3 mph.

Flying Scotsman, London/Edinburgh, 49.1 mph.  
Fleming to Jacksonville FL, 5 miles, 120 mph.

### Fastest Voyages of Various Kinds, by 1930

Fastest day on a sailing vessel, 437 miles in 24 hours.  
Fastest trans-Atlantic passage by clipper ship, 12 days.  
Fastest trans-Atlantic passage by yacht, 12 days, 4 hours.  
Fastest passage between Cherbourg/Southampton, 4 hours and 19 minutes.  
Fastest passage New York/Cherbourg, 5 days, 1 hour, 49 min.  
Fastest day's steamship run: the Mauretania, 676 knots, averaging 27.04 knots per hour.  
Fastest motorboat run: 10 km in 6:12, 58.84 mph.  
Fastest trip around the world: 23 days, 15 hours, 21 min, 3 seconds.

*"They left New York by seaplane and overtook the Olympic off Long Island. From Cherbourg they flew by air across Europe and Asia, reaching Tokyo on July 11. They got by steamer to Vancouver BC on July 20, and flew thence to NYC." — World Almanac, June 29/July 22.*

## THIRTY LARGEST STEAMSHIPS

REGISTERED IN 1920

Name	Reg. Tonnage	Length (feet)	Breadth (feet)
Leviathan	54,282	920	100
Imperator	52,000	858	97
Europa	50,000	911	96
Aquitania	47,000	901	92
Olympic	45,000	890	92
Columbus	35,000	696	76
Mauretania	32,000	790	83
George Washington	25,570	722	78
Kaiserin Augusta Victoria	24,581	677	77
Adriatic	24,541	726	75
Rotterdam	24,170	668	77
Baltic	23,876	726	75
France	23,666	720	75
America	22,622	687	74
Cedric	21,035	680	75
Scythia	21,000	600	73
Celtic	20,904	680	75
Minnesota	20,718	622	73
Caronia	19,594	650	72
Carmania	19,524	650	72
Mount Vernon	19,503	706	72
Aeneas	19,500	500	60
Agamemnon	19,361	684	72
Lapland	18,694	620	70
President Lincoln	18,168	616	68
President Grant	18,072	616	68
Berlin	17,324	612	70
Prince Frederick Wilhelm	17,084	613	68
Cleveland	17,000	608	65
New Amsterdam	16,697	600	69

# SAMPLE DISTANCES, 1920

## MAIL ROUTE DISTANCES BETWEEN EUROPEAN CITIES, 1920, IN MILES

<b>London</b>																				
202	<b>Liverpool</b>																			
287	489	<b>Paris</b>																		
1195	1397	908	<b>Madrid</b>																	
1610	1812	1323	415	<b>Lisbon</b>																
276	472	211	1119	1530	<b>Antwerp</b>															
657	859	587	1495	1804	412	<b>Hamburg</b>														
746	948	674	1582	1889	497	178	<b>Berlin</b>													
618	848	359	1183	1602	460	678	611	<b>Berne</b>												
787	989	500	1073	1506	719	839	837	297	<b>Turin</b>											
980	1182	849	1668	2157	727	605	427	533	720	<b>Vienna</b>										
768	970	582	1477	1897	522	579	401	295	470	266	<b>Munich</b>									
1195	1397	907	1223	1746	1033	1180	1048	639	414	840	647	<b>Rome</b>								
1150	1252	863	1416	1828	1009	1066	838	533	391	370	487	510	<b>Trieste</b>							
1135	1557	1067	1925	2593	895	576	398	1021	1156	436	702	1276	806	<b>Warsaw</b>						
2030	2232	1899	2748	3345	2025	1903	1699	1883	2018	1298	1564	2138	1725	1205	<b>Istanbul</b>					
1917	2119	1760	2635	3117	1737	1418	1240	1545	1680	969	1226	1800	1330	842	363	<b>Odessa</b>				
1915	2117	1843	2904	3414	1706	1387	1209	1832	1967	1247	1513	1087	1617	811	1339	950	<b>Moscow</b>			
1774	1976	1699	2874	3286	1588	1269	1091	1714	2119	399	1395	2239	1769	693	1733	1356	406	<b>Leningrad</b>		
1283	1491	1219	1972	2384	993	580	685	1176	1337	1110	1084	1731	1171	1082	2408	1510	836	430	<b>Stockholm</b>	
919	1131	812	1600	2012	620	208	270	885	1047	897	671	1318	967	668	1510	1510	1252	846	416	<b>Copenhagen</b>

Subtract 20%  
for air distances.

### DISTANCES FROM THE PANAMA CANAL TO VARIOUS PORTS, IN NAUTICAL MILES

Boston, MA	2157	Hamburg, Germany	5070
Baltimore, MD	1901	Leningrad, USSR	6282
New York, NY	1974	Vancouver, Canada	4032
Jacksonville, FL	1535	Portland, OR	3869
New Orleans, LA	1403	San Francisco, CA	3245
Vera Cruz, Mexico	1420	San Diego, CA	2843
Havana, Cuba	1003	Callao, Peru	1346
Rio de Janeiro, Br.	5349	Valparaiso, Chile	2616
Buenos Aires, Arg.	5450	Yokohama, Japan	7682
Cape Town, S. Af.	6574	Shanghai, China	8556
Gibraltar	4343	Hongkong, China	9195
Naples, Italy	5325	Manila, Phillipines	9347
Istanbul, Turkey	6166	Singapore	10505
Port Said, Egypt	6268	Tahiti Islands	4486
Havre, France	4610	Sydney, Australia	7674
London, England	4763	Wellington, N. Zealand	6505

### DISTANCES FROM NEW YORK, NEW ORLEANS AND SAN FRANCISCO TO PRINCIPAL PORTS AND CITIES

	New York	New Orleans	San Francisco
Aden	6532	7870	11500
Bombay	8120	9536	9780
Buenos Aires	5868	6318	7511
Calcutta	9830	11239	8920
Cape Town	6815	7374	9898
Congo River, Mouth of	5862	6580	8853†
Hamburg	3637	5249	8315
Havre	3169	4760	7855
Hongkong	11431	10830	6086
Honolulu	6686	6085	2097
London	3233	4507	8038
Manila	11546	10993	6289*
Melbourne	10628	9437	7040
Mexico City**	2898	1626	2512
Nome	8010	7410	2705
Port Said	5122	6509	9562
Punta Arenas	6895	7340	6199
Rio de Janeiro	4778	5218	7678
Leningrad	4632	6223	7823†
Shanghai	10855	10254	5550
Singapore	10170	11500	7502
Valparaiso	4637	4035	5140
Vladivostok	10001††	9410††	4706
Wellington	8540	7939	5909
Yokohama	8986††	7762††	4536

Distances are shortest water routes available, except as specially noted.  
All water distances are in nautical miles.

\* Route is via Yokohama.

\*\* All three routes are entirely by land.

† Via New York by land.

†† Via San Francisco and Tehuantepec by sea.

### DISTANCES BETWEEN CITIES OF THE UNITED STATES BY LAND, IN MILES

	New York	New Orleans	San Francisco
Atlanta, Georgia	876	496	2810
Boston, Massachusetts	235	1607	3313
Charleston, S. Carolina	739	776	3119
Chicago, Illinois	912	912	2279
Columbus, Ohio	637	945	2593
Dallas, Texas	1769	515	1932
Denver, Colorado	1930	1357	1376
El Paso, Texas	2310	1195	1287
Helena, Montana	2452	2152	1255
Jacksonville, Florida	983	616	3098
Los Angeles, California	3149	2007	475
Memphis, Tennessee	1157	396	2439
Minneapolis, Minnesota	1332	1285	2101
New Orleans, Louisiana	1372	—	2482
New York, New York	—	1372	3191
Pittsburgh, Pennsylvania	444	1142	2747
Portland, Oregon	3204	2746	722
San Diego, California	3231	2088	602
San Francisco, California	3191	2482	—
Seattle, Washington	3151	2931	957
St. Louis, Missouri	1065	699	2199
Washington, D.C.	228	1144	3069

These distances are entirely by land; water or land/water routes in some cases will be shorter. Figures are as established by the War Department, for the year 1920.

# Prices & Cash

Until the Great War, the United States was a debtor nation internationally, still paying off the vast European (particularly British) investments that had gone to fund such vital improvements as the national railway system. The Great War, however, liquidated all participant holdings in the United States, either through seizure (in the case of Germany, for instance) or through payment for military aid. While it is true that almost no state ever repaid its war debt to the U.S., this nation received payment enough: not until OPEC in the early 1970's would it be a debtor nation again, with persistent balance-of-payments problems.

Buoyed by elimination of foreign control and increased gold reserves, and initially fueled by the heavy inflation accompanying WWI, the 1920's were a generally favorable era for economic expansion and profit. Throughout the decade prices and wages remained relatively stationary with respect to each other, and inflation appears to have been effectively about 1% per year. By policy, the dollar was convertible to gold; silver prices consistently slumped.

## Average Price of One Fine Ounce of Gold or Silver On the London Market, in Dollars, 1920-1930

Year	Gold	Silver
1920	\$27.49	\$1.35
1921	26.05	.81
1922	22.71	.75
1923	21.96	.67
1924	22.80	.74
1925	20.80	.70
1926	20.66	.63
1927	20.67	.57
1928	20.67	.59
1929	20.67	.54
1930	20.68	.39

Since the U.S. was on the gold standard at this time, gold can be bought and sold like any other commodity. The advantages of the era will be obvious to any adventurer: not only were all precious metals translatable, but foreign currencies could be pegged directly to the gold price if any exchanges became necessary during an adventure.

## Wages

As an example of a wage spectrum within a particular industry, here are the national average yearly sums received by railroad labor and management over thirty years.

Year	General		Section			Laborer
	Officer	Clerk	Foreman	Crpnter	Conductor	
1900	3260	683	524	636	989	533
1914	5011	792	686	830	1395	686
1920	6347	1647	2254	1808	2971	1306
1928	7000	1645	1558	1500	3118	1083

Note the drop off in wages among some of the occupations by 1928. This is partially prompted by the worsening financial condition of the railroad industry as a whole, which includes the short commuter trains and trollies under heavy competition from the automobile by 1928. Worsening conditions also impress upon business the desirability of 'piece-work' labor, which does not need to be paid for unless it is used. These yearly rates should not necessarily be taken as indicators that the hourly wage decreased, only that the number of such hours on the averaged decreased.

## Taxes

Law-abiding adventurers should be paying a small local property tax if they own land (to finance the schools), and about 5% yearly to the federal government if the adventurer is making more than \$20,000 yearly. There are no sales taxes during this time, as a general rule.

## Prices

The following prices have been arranged in categories commonly of interest to globe-hopping adventurers. The prices are representative of the year 1920, but should not be taken to indicate that any one item (such as a Model T Ford) exactly costs the listed price. Additionally, there is slight inflation averaging about 1% a year over the decade, and referees interested in that sort of thing may wish to adjust costs as the years of the campaign progress.

### TRANSPORTATION COSTS

Automobile/Truck		Animal	
used auto	\$250.	OK saddle horse	\$400.
new cheap auto	1000.	old saddle horse	200.
luxury auto	7000. tops	mule	100.
used truck	350.	burro	50.
small truck	1400.	sled dog	50.
large truck	3500. up	buggy	85.
med. auto tire	12.	farm wagon	65.
tire chains	5.	double horse harness	45.
tire rpr kit/pump	2.50	western saddle	20.
tire jack	1.		
auto spotlight	3.	Ship*	
auto battery	15.	ferry, .15 first mile, .05 each	
gasoline, gallon	.20	additional mile	
average mpg, 30		liner, \$60 per 1000 miles or	
repair book	1.50	fraction thereof	
		freighter, \$30 per 1000 miles	
Trains		or fraction thereof	
local commuter	.05	tramp, \$15 per 1000 miles	
+ .02 per zone		or fraction thereof	
medium range 25-400		rowboat	\$35.
miles, 1. + .02 per mile		canoe	75.
transcontinental, 1. + .01		outboard motor	80.
per mile**			
Air Travel		Bicycle, suitable to attach	
1919 cost from London		motor to	28.
to Paris was £21 (\$100)			
1930 av. price was .09-.60			
per passenger mile			

\* These prices are for good to excellent accommodations. The relation between cost, speed, and reliability is given in *Ship Speeds*, p. 18.

\*\* There are no transcontinental lines in this period. Characters always will have to transfer when going across the U.S. Chartered trains (called 'specials') can go across the nation by special arrangement.

### CAMPING GEAR

Cheap trunk (40 lbs.)	\$4.	2-man tent (39 lbs.)	\$12.
Expensive trunk (55 lbs.)	10.	4-man tent (62 lbs.)	22.
Water bag, 1 gal.	1.	8-man tent (92 lbs.)	35.
Water bag, 5 gal.	2.	25-man tent (233 lbs.)	95.
Camp stove	6.	16 x 20 tarpaulin	15.
Cooking kit	9.	Hunting knife	3.
Camp cot	6.	Kerosene lantern	2.
Good quart thermos	5.	Light rod and reel	10.
Fishing tackle outfit	10.		

**LODGING AND DINING**

Flophouse (guard your valuables)	\$ .20 night
Dingy (but you get a private room)	1.00 night
Comfortable (good bed, hot water)	5.00 night
Deluxe (bell-boys, tippable)	10.00 night and up
Deluxe meal on train	1.50
Good meal in restaurant	.75
Good breakfast	.30
Dozen eggs at the store	.50
Quart of milk at the store	.15
Loaf of bread at the store	.25
Pound of bacon with little fat	.45
Excellent cigar after your meal	.20

**CLOTHING**

These are standard items of apparel, often useful for re-outfitting the adventurer who has escaped deadly peril sans clothing.

Man's topcoat	\$14.
Rain slicker and hood	5. up
Hiking/riding suit	12.
Quality woman's dress	15.
Woman's wool coat	14.
Hunter's coat	5.
Hip boots	6.
Union suit	1.
Man's shirt	1.
Woman's frock	5.

**EQUIPMENT FOR ADVENTURERS\***

Shoulder holster	\$ 1.25	Plated cross, 10" high	\$ 2.
Money/cartridge belt	2.25	Wind-up alarm clock	3.
Gasoline table lamp (runs 12-15 hours)	6.50	6X binoculars	24.
100X microscope	17.50	12-G shotgun shell, 500	20.
Baseball bat	1.50	.22 bullets, 200	1.
Varmint trap	.50	.45 bullets, 100	3.
Pocket knife	.50	.30 carbine bullets, 100	9.
Pencil	.01	Box camera	6.
Popular novel	1.50	3-cell flashlight	2.
Flashlight battery	.10	Holy Bible	4.
Carbide spelunker lamp (runs 9-10 hours)	5.00	144 8x10 photopaper	5.
Tablet	.05	Photolab equipment	15.
		Battery spot light	5.
		Flapped pistol holder	1.

\* The particular rules you are using may also have priced items.

**MISCELLANEOUS GEAR FOR ADVENTURERS**

Wrist watch	\$25.	Shovel	\$ 1.
Pocket watch	15.	Axe	2.
Cheap signet ring	4.	1/2" steel link chain, per foot,	.25
Good fountain pen	3.	Carpenter tool set	50.
48-piece jeweler kit	16.	Blacksmith tool set	80.
6 needle files	1.	Plated cavalry trumpet	7.
Rubber gloves	.75	Typewriter	65.
Wheelchair (75 lbs)	40.	Ukelele	8.
Ordinary violin	35.		
Rope, per 100', 1/2"	3.		

These items can be potentially useful, but usually are not part of an Adventurer's utility kit.

**Banks and Savings**

Banks in this period are completely independent entities, and whether or not they thrive or collapse depends upon the stockholders and managers of the bank and on general economic conditions. There is no federal insurance on private

savings, for instance, nor are there federal limits as to how much or how little interest a bank pays. The interest rates on loans may be regulated in some areas, for a ceiling rate may be in effect, but often they may not be.

In general, the better the interest rate on a savings account, the shakier the bank will be. Any rate above 3% probably indicates that the bank unduly needs cash. It may be amusing to tempt player-characters with high interest rates. The characters also may occasionally lose their savings in a bank collapse, and regain part or none of it months later—but this should happen rarely.

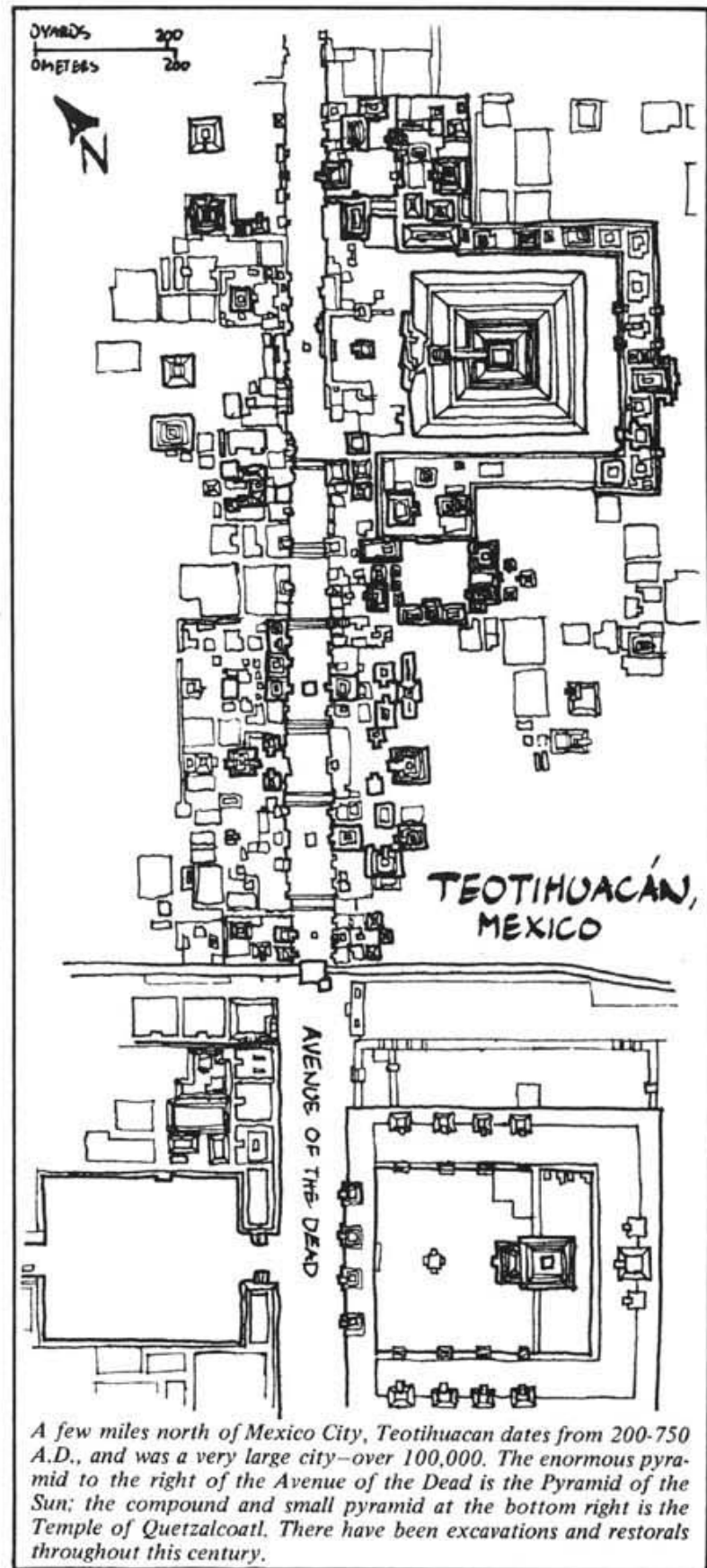

A few miles north of Mexico City, Teotihuacan dates from 200-750 A.D., and was a very large city—over 100,000. The enormous pyramid to the right of the Avenue of the Dead is the Pyramid of the Sun; the compound and small pyramid at the bottom right is the Temple of Quetzalcoatl. There have been excavations and restorals throughout this century.

# Weapons

It was perhaps in the 1920's that the strangest weapons mixtures in all of history were found. While the imperial rivalries that led to the Great War had introduced the gamut of automatic weapons known to us today, their technologies and economies of production had not yet penetrated many parts of the world. At no other time was the military disparity between the colonizer and the colonized as great. In interpreting the tables below, you will need also to determine the status or race of the group to be rolled up: are they Boers or Zulus? Are they American cowboys or Digger indians? Use these tables judiciously, to reflect the realities of the time as accurately as you can.

In order to arm random civilian groups, the world has been divided into eleven areas, the chief differences of which are climate and consequent affluence. All of the groups are considered to be rural, not urban: for urban groups, half of each such party should not be armed at all, or armed only with the most casual weapons possible—sticks, bricks, straight-edge razors, and so on. Handle boundary areas between zones as you wish. The demarkations are suggestive, not authoritative.

Referring to the accompanying map, World Weapon Zones, roll 1D20+4 for the number in the group, then roll 1D10 to arm each individual in the posse, mob, robber band, or group of justifiably outraged citizens.

## WEAPONS ZONES

### ZONE 1 – Western and Middle Europe

roll 1D10	result
1	club
2-3	shotgun
4-6	ax
7-9	scythe or sickle
0	rifle

### ZONE 2 – Eastern Europe and the Russias

roll 1D10	result
1-3	club
4-5	ax
6-7	scythe or sickle
8-9	whip
0	shotgun

### ZONE 3 – Sub-arctic, New Guinea & Borneo interiors, SW Africa

roll 1D10	result
1-3	club
4-5	knife
6	hatchet
7-9	spear
0	bow

### ZONE 4 – North Africa, the Mid-East, Trans-Caspia

roll 1D10	result
1-4	knife
5-6	sword
7-9	musket
0	rifle

### ZONE 5 – Asian mountains, Tibet

roll 1D10	result
1-3	club
4-6	knife
7-8	spear
9	sword
0	rifle

### ZONE 6 – south Canada, U.S.A., non-jungle Mexico, settled South America, white S. Africa, Australia

roll 1D10	result
1-2	knife
3-4	ax
5-6	pistol (not allowed in Canada; make club instead)
7-8	shotgun
9-0	rifle

### ZONE 7 – jungle areas between Mexico and Argentina

roll 1D10	result
1-2	club
3	knife
4-5	spear
6-7	poison dart
8-9	bow
0	rifle

### ZONE 8 – India, China, Japan

roll 1D10	result
1-3	club
4-5	knife
6-7	torch
8-9	sickle
0	sword

### ZONE 9 – Southeast Asia

roll 1D10	result
1-4	club
5-6	spear
7	sword
8-9	bow
0	musket

### ZONE 10 – jungle and savanna of Africa

roll 1D10	result
1	club
2-5	spear
6-7	javelin
8-9	bow
0	musket

### ZONE 11 – aboriginal Australia

roll 1D10	result
1-2	club
3	knife
4-6	spear
7-9	boomerang
0	bow

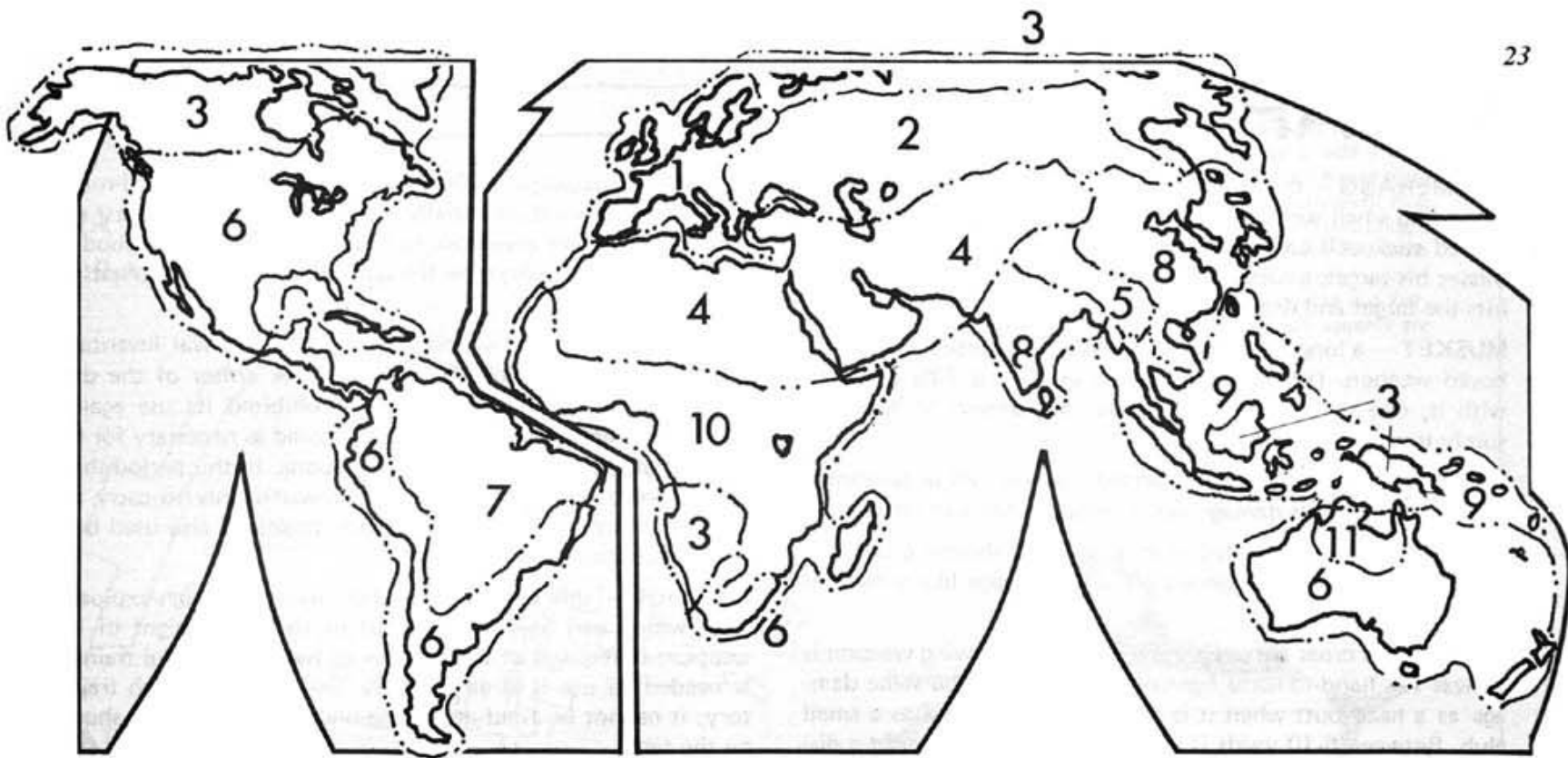

### Cultural Weapons Around the World

Remember that these groups are armed spontaneously. With time, they might all be able to arm themselves in a more deadly fashion. But when an adventurer needs help, he probably needs it quickly. And when he runs into a flock of villains, they may not have been waiting just for him—even bad guys sometimes have other things to do.

### New Weapons for CALL OF CTHULHU

Name	Type	Damage	Base Chance	Hit Points	Range	Cost	Notes
Boomerang, War	thrown	1D8	10%	8	30 yards	\$10	—
Musket	firearm	1D8+4	20%	12	40 yards	\$50	impales
Scythe	2-handed	2D6	10%	20	melee	\$20	—
Sickle	hand	1D6+1	20%	12	melee	\$15	impales
Whip	hand	1D3	05%	6	5 yards	\$10	entangles*
Submachinegun (Thompson)	firearm	1D10+2 (automatic)	15%	8	20 yards	varies	impales
.30 machine gun	firearm	2D6+3 (automatic)	05%	10	50 yards	varies	impales
.50 machine gun	firearm	2D6+10 (automatic)	05%	10	100 yards	varies	impales
Two-inch mortar	projectile	4D6 (3 yard radius)	00%	15	20/100 yds	varies	explosive
Hand Grenade	thrown	3D6 (3 yard radius)	Throw%	5	thrown	varies	explosive
Dynamite Stick	thrown	5D6 (1 yard radius)	1/2 Throw%	1	thrown	75 cents	explosive
75mm field gun	projectile	10D6 (2 yard radius)	00%	25	100 yds	varies	explosive

**WHIPS:** On an "impaling" hit (1/5 normal chances to hit), the whip's wielder can specify whether the whip wraps around an object in the target's possession and yanks it out of his grip, or entangles a chosen body part, immobilizing it.

**AUTOMATIC WEAPONS:** Fully-automatic weapons, such as Thompson submachine guns, may fire more than a single shot on the user's DEX. For each shot fired in a burst, the attack chance is lowered by 5%; except that no matter how many shots are fired, the chance will not drop below 1/2 the user's proficiency with the weapon. Roll once for all attacks against a single target. If the attack succeeds, roll an appropriate die to determine how many bullets actually hit. For example, if 8 shots are fired, 1D8 is rolled to determine the number of hits. If 3 shots are fired, 1D3 is rolled. Only the first bullet will impale if an impaling hit is rolled. If more than one target is attacked, the user loses one shot per extra target aimed at. Each target must be attacked to hit separately.

**EXAMPLE:** Ohio Jones is investigating mysterious sights and sounds occurring around a top-secret U.S. military base. He discovers a dead guard and picks up the guard's tommygun as a horde of wild-eyed cultists charge out of the building which the guard was tending.

Ohio holds down the trigger and empties the magazine at them. He has a 15% chance to hit, and the magazine holds 20 shots, so 100% would normally be subtracted from his chances of hitting, but the lowest he can be reduced to is half his normal chance to hit, or 8% in this case. He decides to spray the nearest five cultists, aiming 4 shots at the first (and biggest), 3 at the second, 3 at the third, 3 at the fourth, and 3 at the fifth. Since he must also lose a shot in between each target, his full 20 shots are used up. He rolls a 01 vs. his first target, a 55 for the second, a 03 for the third, a 08 for the fourth, and a 05 for the last. What luck! The first victim takes 1D4 hits, of which the first impales (a 2 is rolled), while the other three targets actually hit take 1D3 each. All end up taking sufficient damage to be killed instantly. Since Ohio was weakened by malaria at the time, the keeper rules that the Thompson's recoil knocked him off his feet, and that he let go of the gun.

The remaining cultists, dismayed by the carnage, leave him and his tommygun there as they run for the jungle.

**EXPLOSIVES:** Damage for all explosives is listed with a radius. The damage done by the explosive will decrease by 1D6 for every increment of that radius distance that a particular target stands. All targets within the radius roll the explosive's damage separately to determine the total damage suffered.



# WEAPONS NOTES

---

**BOOMERANG** — this 'throwing-stick' is intended for killing or wounding small game. In the hands of an expert, the specially curved stick will come back to the user's general vicinity if he misses his target; a successful throw means that the boomerang hits the target and drops to the ground.

**MUSKET** — a long-barreled, often hand-made, usually smooth-bored weapon. Its users may attain at least a 70% accuracy with it, due to long familiarity, but newcomers to it will be sorely tested even to load it.

**SCYTHE** — the massive two-handed reaping tool of peasantry everywhere. It does damage like a wood ax, but can impale.

**SICKLE** — a curved-bladed reaping tool for shorter grains and grasses. It is used one-handed. It does damage like a hatchet but can impale.

**WHIP** — this cross between a melee and a throwing weapon is useless for hand-to-hand fighting, doing about the same damage as a head butt when it is doubled up and used as a small club. Between 5-10 yards it inflicts 1D3 of damage and a disconcerting slap of pain. An entangle with the whip means that it has wrapped around the target object that the user desired, and that the target object now can be snatched from the grip of its holder unless the holder makes a DEX x 1 roll or has specified he is guarding against this maneuver (when he needs a DEX x 5 roll). If wrapped around a limb, or a successfully-held item, the whip user can attempt to pull the target off his feet with a successful STR vs. STR roll on the resistance table.

**THOMPSON SUBMACHINE GUN** — the tommygun was invented in 1918 as a weapon with which to end the Great War. The war ending anyway, the gun was available generally for a short while, a favorite of company police and other hired gunmen. However, it was quickly outlawed for civilian use, and from then on only criminals and certain police forces had access to it. The famous 100-round drum was cumbersome and almost never was used.

**MACHINE GUN, .30** — this is the traditional light machine gun used by nearly every armed force of the day. Though John Wayne might have been able to fire it from the hip, in your play it will take two men to fire it from a tripod. It is water-cooled and has a 20% chance of jamming any time it is used

for a 'full magazine' (20-round) burst instead of a 3-round burst. Its ammunition usually comes in 500-round belts, and without a second crewman to load the gun the likelihood of jamming is 20% everytime the gun is fired, 3-round bursts or not.

**MACHINE GUN, .50** — another end-the-Great-War invention, it was meant to punch through the tank armor of the day. Though later conventions of war prohibited its use against personnel, those prohibitions were ignored as necessary for the survival of the crews serving the weapons. In this period these water-cooled weapons need 3-man crews—if only to carry the gun, its tripod, and the ammunition boxes. It also used belt-fed ammunition.

**MORTAR** — this device fires a high-trajectory high-explosive shell which can reach targets out of the line-of-sight of the weapon. It requires at least a crew of two, and careful training is needed to use it at all properly. Because of its high trajectory, it cannot be fired at a range under the first figure shown on the table.

**HAND GRENADE** — contains a high explosive in a brittle metal container which will shatter into shards of shrapnel; it is the shrapnel which causes most of the damage. A hand grenade has two catches which must be released before it will explode; the nominal time of explosion after the second pin is pulled will be about four seconds.

**DYNAMITE STICK** — to throw a single stick of dynamite, the character must have inserted a fuse and lit it; a dynamite stick will take one melee round to 'fuse' and a second one to light and throw it. The stick will go off after all other action has ceased in the second melee round. Packs made up of more than one stick of dynamite cannot be thrown. Immobile dynamite mines of any size can be created, and they can be exploded by burning fuse, electrical discharge, or by a very strong impact, such as a bullet.

**75mm FIELD GUN** — this is a mobile towed field gun with a firing shield, similar to the French '75. The base chance in the table assumes a trained militia crew. The range is based on visual sighting and fire by the gun crew. Shells may be armor-piercing or high-explosive.

# BLACK MARKET WEAPONS

---

Characters desiring heavy weapons will not find them in the Sears, Roebuck catalog, and neither will they find them inexpensive or legal. No police force in the world will help PCs buy such weapons unless they are intended for export—and then are exported. No honest police force will ever help characters bring such items as machine guns into a country.

Even if the weapons are intended for export, the arms market is such that there is a 25% chance per total purchase that the goods will prove undeliverable, or that the sellers will steal the money and not deliver the goods, or that the police will break up the proceedings.

*Thompson SMG* — 1D10 x \$50 + 150 for one weapon; 1D6 x \$50 for lots of 20 or more.

*.30 cal MG* — 1D100 x \$15 + 300 for one weapon; large lots unavailable.

*.30 cal MG ammunition* — 500-round ammo belt \$100.

*.50 cal MG* — 1D100 x \$30 + 400 for one weapon; large lots unavail.

*Mortar* — 1D6 x \$200; unavailable in lots.

*Mortar ammunition* — \$2 per shell; 1/3 will be duds.

*Dynamite* — if refused legal purchase, \$2 per stick.

*75mm field gun* — 1D100 x \$100 + 800 per weapon; weapons which cost less than \$3000 will have an accuracy limited to 200 yards.

*75mm field gun ammunition* — \$10 per shell, specify armor piercing or high explosive. Half of the shells will be duds.

*Hand grenade* — \$50 per box of 24; 40% will be duds.

HASANLU,  
IRAN

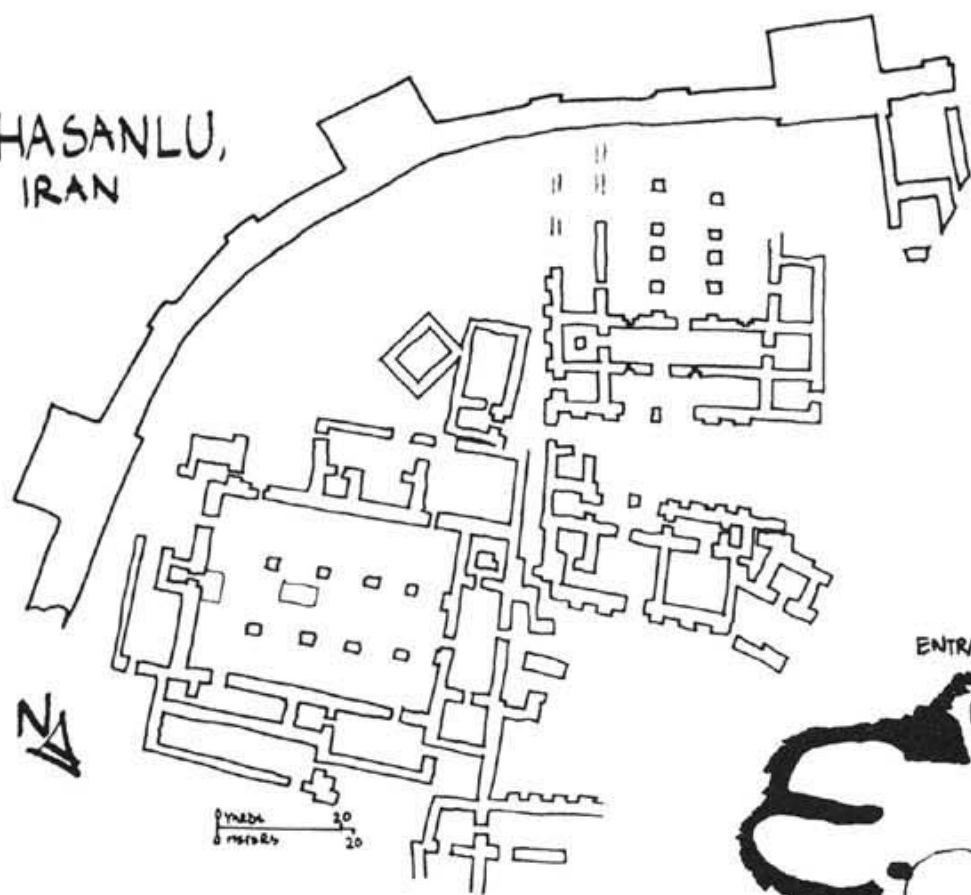

Hasanlu is in extreme northwest Iran. The period shown in this drawing was ended abruptly by battle and fire. Archaeologists were fascinated to uncover extremely rich finds which date from 800 B.C., including a man clasping a golden bowl who had been killed by a falling beam. The curving section at the left and top of the drawing is a portion of the city wall. The small squares are individual pillars in the buildings.

This Ohio site is encircled by earthen walls, and within it are a number of burial mounds, dating from about 800 B.C. to 600-700 A.D. The important folk being buried were first placed in log-lined excavations, then earth was formed over them in heights up to 30 feet. Valuable objects from all over the continent have been found in such mounds.

MOUND CITY,  
U.S.A.

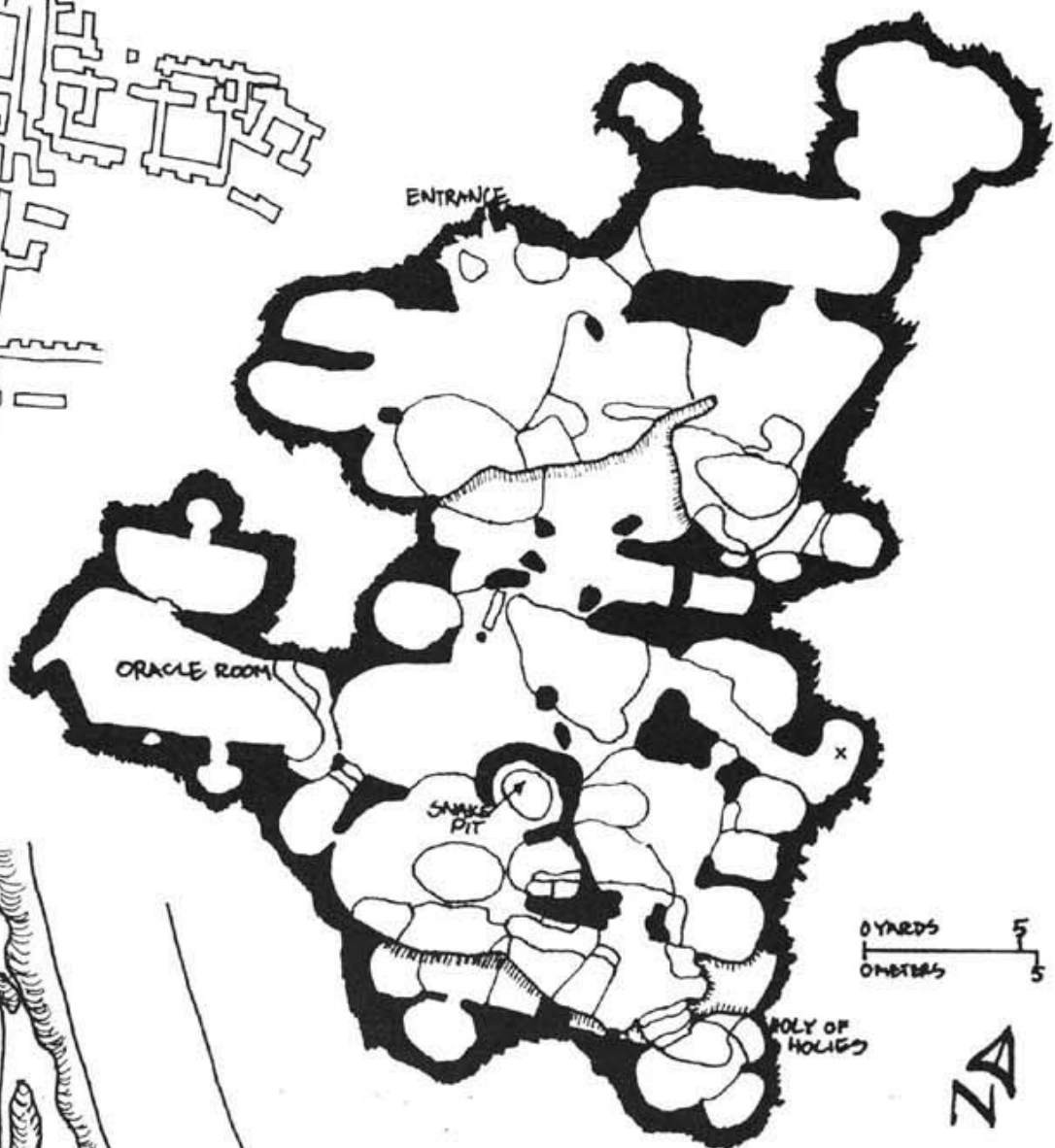
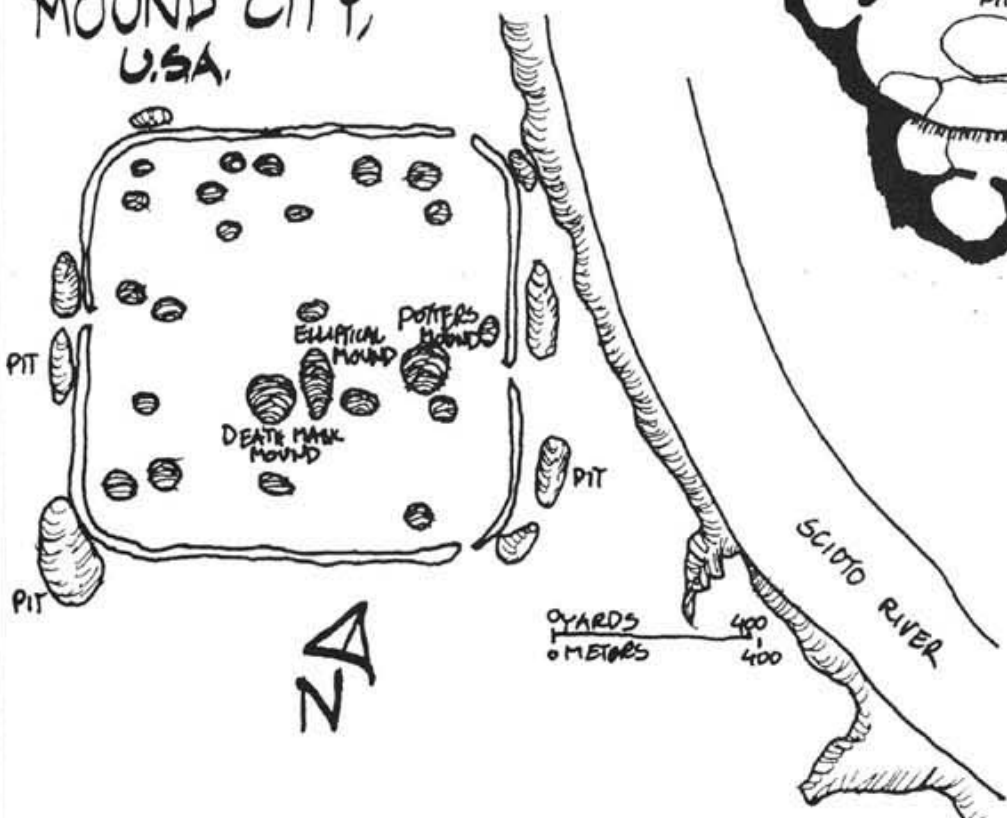

HAL SAFLIENI,  
MALTA

These burial caves on Malta have been hewn into the limestone since 4000 B.C. Newer sections were added and older parts sealed off. Original finds included vast quantities of human bones, beads, amulets, and other personal items. The indicated entrance is the original entrance; the present-day entrance is via a stairs where the small 'X' is, just an inch or so above the diagram scale.

# Beasts & Monsters

Some keepers may wish to add a variety of natural and unnatural animals and beings to their games. The following stats and notes provide a variety of new creatures for use with CALL OF CTHULHU. More such beings certainly can be devised, and those presented here easily can be modified for special circumstances. The most obvious special circumstance is a need to change the size of an animal type. For instance, a keeper may want a Kodiak bear or a polar bear instead of the common black bear presented here. In that case add a D6 or two to the stats for STR, CON, and SIZ. Remember also that the damage that a bigger, stronger, tougher paw swipe would do will increase also.

## POTENTIAL SAN LOSSES

The following are potential SAN losses that can be incurred when an Investigator views or is surprised by one of these creatures:

CREATURE	SAN LOSS
Bat, Bear, Dog, Condor, Crocodile, Gorilla, Horse, Lion, Elephant, Python, Rat, Squid, Tiger, Wasp Swarm, Wolf. . . . .	None
Ghost, Wraith, Zombie . . . . .	1D8+
Mummy, Werewolf . . . . .	1D8
Human Skeleton, Vampire. . . . .	1D6
Pixie . . . . .	1D3

## BAT, LARGE

Characteristics	Average	
STR 2D4	5	Move 1/12 flight
CON 2D6	7	Hit Pts: 6
SIZ 2D4	5	
POW 2D6	7	
DEX 1D6+18	21-22	

Weapon	Attack	Damage
Bite	40%	1D4

OTHER SKILLS—Spot Hidden Items 75%.

HABITAT—warm and temperate climates world-wide.

## BEAR, COMMON BLACK

Characteristics	Average	
STR 3D6+6	16-17	Move 8
CON 2D6+6	13	Hit Pts: 15
SIZ 3D6+6	16-17	
POW 3D6	10-11	
DEX 3D6	10-11	

Weapon	Attack	Damage
Bite	45%	1D6+1D8
Claw	30%	1D6+1D6
Hug	30%	3D6

A bear either may bite and claw twice OR bite and hug in a melee round. If choosing to bite and hug, both attacks must be against the same foe. If the bear bites and claws twice, he may attack up to three separate foes.

ARMOR—2 point skin.

OTHER SKILLS—Track 40%, Climb 50%.

HABITAT—temperate climates, brushy or wooded areas.

## DOG, ORDINARY

Characteristics	Average	
STR 2D6	7	Move 12
CON 3D6	10-11	Hit Pts: 8
SIZ 1D6+1	4-5	
POW 2D6	7	
DEX 2D6+6	13	

Weapon	Attack	Damage
Bite	30%	1D6

OTHER SKILLS—Track by Smell 80%, Spot Hidden Item 60%.

Dogs usually hunt in packs of 1D8+3.

HABITAT—everywhere.

## CONDOR or EAGLE, GIANT

Only the largest birds will attack a man, though a vulture might attack a helpless man. All birds have the special ability to cut an attacker's chance to hit in half while flying.

Characteristics	Average	
STR 3D6+12	22-23	Move 5/12 flight
CON 3D6	10-11	Hit Pts: 14
SIZ 3D6+6	16-17	
POW 2D6+6	13	
DEX 2D6+12	19	

Weapon	Attack	Damage
Bite	45%	1D8+1D6
Claw	45%	1D6+1D6

ARMOR—2 point feathers.

HABITAT—the higher hills and mountains which offer safe nesting sites. Nests may be among pinnacles or on rocky ledges, or even in trees which have grown close together and can support the considerable weight of several to a half-dozen large birds and nest. Range is basically western hemisphere, but there is no reason as far as adventures go that a referee simply cannot say, 'A giant bird is diving at you' in any place this side of Antarctica, where the only giant birds walk.

## CROCODILE, NINE YARDS LONG

Characteristics	Average	
STR 3D6+30	40-41	Move 7
CON 2D6+12	19	Hit Pts: 30
SIZ 3D6+30	40-41	
POW 3D6	10-11	
DEX 2D6+3	10	

Weapon	Attack	Damage
Bite*†	60%	1D10+4D6
Tail Lash*††	60%	1D6+4D6

\* Bite and tail lash may strike simultaneously, but not at the same opponent.

† If the croc is in water, it will cling with the bite and spin, doing its damage bonus each round.

†† Roll STR x 5 or less on D100 or fall down immediately.

ARMOR—10 point skin.

HABITAT—jungle marshes across the globe.

NOTES—the crocodile presented is very large. For smaller, garden-variety crocs, divide STR, CON, SIZ, and POW by 2 or 3 and make the damage add +1D6 rather than +4D6.

## WASP SWARM (OR ENRAGED BEES)

This swarm of stinger-equipped, flying insects will attack for 2D6 melee rounds. Unless the victims are completely covered (as with netting or by being enclosed in an auto) there will be no protection against them.

Weapon	Attack	Damage
1D10 stings	15%	1 per sting

HABITAT—deserts, woods, plains, and jungles.

ALTERNATE SYSTEM—the wasp swarm can last 1D6+1 melee rounds with characteristics varied by a 1D4 roll:

Roll	Weapon	Attack	Damage
1	1D4 stings	100%	1 per sting
2	1D6 stings	100%	1 per sting
3	1D8 stings	100%	1 per sting
4	1D8 stings	100%	1 per sting

## GHOSTS

Each ghost should be individually crafted by the referee for the circumstances appropriate. Ghosts generally possess only the characteristics of INT and POW, appearing in a misty form. When matching their POW vs. their victim's POW, the ghost appears to be clawing at, enveloping, or otherwise physically attacking the victim.

'Ordinary' ghosts attack each melee round by matching their POW vs. the POW of the victim on the resistance table. If the ghost overcomes the POW of the victim, the victim loses 1D3 of POW. If the victim can overcome the ghost, he causes it to lose 1D3 points of POW. Some ghosts may be of great strength, draining 1D6 POW or more from a victim in a single melee round, but such powerful ghosts still will lose only 1D3 POW if overcome by the victim in a particular round.

'Individually crafted' ghosts can be sources of good, spooky scenarios. Entire campaigns can be devoted to the study of and the exorcising of ghosts. Books to read before crafting individual ghosts include *The Haunting of Hill House* (both the novel and the film, in fact) by Shirley Jackson, *The Shining* by Stephen King, any of William Hope Hodgson's ghost stories (particularly the Carnacki-Ghost Hunter tales), and any ghost stories written by Montague Rhodes James [M. R. James]. Some of these books may prove difficult to get hold of (like the ghosts they portray), but most public libraries should have them. Good luck on your library rolls.

## GORILLA

Characteristics		Average	
STR	4D6+12	26	Move 8
CON	3D6	10-11	Hit Pts: 15
SIZ	2D6+12	19	
INT	1D6+1	4-5	
POW	3D6	10-11	
DEX	3D6+6	16-17	

Weapon	Attack	Damage
Bite*	45%	1D6+2D6
Hand*	45%	1D6†

\* Gorillas can bite and attack with both hands in one round.

† If the gorilla hits with both hands, it will grapple its foe, doing the gorilla's damage bonus in damage to the victim in each successive round until the victim breaks the gorilla's grasp with a successful STR vs. STR roll on the resistance table. A gorilla can bite while grappling. A grappled victim cannot melee with weapons longer than a dagger or hatchet.

ARMOR—2 points.

If provoked, the gorilla may act violently, but is normally peaceful and shy.

## HORSES

The best of horses can be described politely as stupid; extremely stupid horses are common. For the purposes of role-playing, horses are divided into three classes: the cart horse, the cavalry horse, and the riding horse.

### THE CART HORSE

This class includes all the animals used as beasts of burden—horse, mule, burro, llama, etc. They may or may not be usable as riding animals, but their training is such that they will not move much faster than a broken trot, and will not even trot for very long. Around angry people or the sound of gunfire, their only interest will be to flee.

### THE CAVALRY HORSE

A cavalry horse is trained to stay calm in battle, carrying its rider where he wants to go. Such horses are not trained to fight independently or to fight in coordination with their riders: a rider would have to make Ride rolls and do nothing else if his horse commenced fighting for any reason. Such a horse probably will stay before natural and unnatural creatures.

### THE RIDING HORSE

A riding horse will carry a rider and gear for a goodly distance during a given period if the horse receives adequate care and feed. Grass is not good food for horses that must do heavy work; oats and other grains can better maintain horses used to such a diet, but such high-energy food will have to be carried along. Riding horses will not fight unless cornered or unless in a territorial fight with another horse. Horses almost never will fight to kill another horse.

Characteristics		Average	
STR	3D6+18	28-29	Move 12
CON	2D6+6	13	Hit Pts: 20
SIZ	4D6+12	26	
POW	3D6	10-11	
DEX	3D6	10-11	

Weapon	Attack	Damage
Bite	05%	1D10
Kick†	05%	1D8+2D6
Rear/plunge*	05%	2D8+2D6
Trample††	25%	4D6 to downed foe

† There is a 65% chance the blow will knock down a target of SIZ 12 or less, with 10% less chance for every 6 points of SIZ larger.

\* There is a 10% chance for every 6 SIZ points over 12 that the target will not fall down, if it is still alive and capable of standing. A horse that rears and plunges can make no other attack.

†† A horse will only trample when directed to do so; they will not trample ordinarily. A trampling horse can make no other attack.

ARMOR—1 point skin.

HABITAT—plains, steppes, and temperate climates.

## LION

Characteristics		Average	
STR	2D6+12	19	Move 10
CON	3D6	10-11	Hit Pts: 14
SIZ	3D6+6	16-17	
POW	2D6+6	13	
DEX	2D6+12	19	

Weapon	Attack	Damage
Bite*	40%	1D10+1D6
Claw*	60%	1D6+1D6
Ripping*†	80%	4D6

\* Gets two claw attacks and one bite attack in a melee round; all must be used against the same opponent.

† If it scores hits with both claws, it will hang on and rip with its hind legs from then on, and may continue to attack by biting as well.

ARMOR—2 point skin.

HABITAT—Africa and Near East.

## ELEPHANT (MAMMOTH)

Characteristics		Average	
STR	4D6+36	50	Move 10
CON	3D6	10-11	Hit Pts: 31
SIZ	4D6+36	50	
POW	3D6	10-11	
DEX	2D6	7	

Weapon	Attack	Damage
Gore*	65%	1D8+5D6
Trample	75%	10D6

\* Instead of goring an elephant may attack with its trunk. The percentage chance of success is the same as its chance to gore, but no damage is done. Instead, the victim must roll STR vs. half the animal's STR or be placed in position to be automatically trampled on the next round. Alternately, the beast may fling away the victim, doing falling damage to the victim based on 1 yard distance per every 3 points of the mammoth's STR. For every 6 SIZ points over 16 that the victim has, he lands 2 meters closer and thus takes less damage.

The trunk of all elephants is sensitive, and will not be used for fighting unless the beast is made desperate by losing half or more of its total hit points.

## MUMMY

These undead beings are similar to intelligent zombies. Some cults keep mummies in their temples as guardians. Like zombies they must be hacked apart before they cease action. Contrary to popular belief, many mummies lack bandage wrappings and move relatively swiftly. Like vampires, mummies have no true POW of their own, and cannot replace it normally if spent. Mummies are effective fighters, and will have a minimum percentage attack chance of DEX x 5..

Characteristic		Average	
STR	3D6 x 2	20-22	Move 6
CON	3D6 x 1½	15-17	Hit Pts: 13-14
SIZ	3D6	10-11	
INT	3D6	10-11	
POW	1D6+12	15-16	
DEX	2D6	7	
CHA	1D6	3-4	
Weapon	Attack	Damage	
Fist	70%	1D6+1D4	
any weapon except firearms	50%	as per weapon + 1D6	

ARMOR—2 point skin plus any worn armor.

OTHER SKILLS—Move Quietly 50%.

Mummies are so horrendous, and their stench of bitumen and death is so strong, that there may be an effect upon a viewer's consciousness or sanity.

## PIXIE

Loosely-run campaigns occasionally may want to have some of the 'little folk' drop in. Pixies are diminutive elves capable of flight with small transparent wings. These imps tend to use the sling. They are naturally invisible, although they become visible if they attack, and spend most of their time playing pranks on travellers in the woods.

Characteristics		Average	
STR	2D4	5	Move 3/10 flight
CON	3D6	10-11	Hit Pts: 7
SIZ	1D6	3-4	
INT	3D6	10-11	
POW	2D6+6	13	
DEX	4D6	14	
CHA	3D6	10-11	
Weapon	Attack	Damage	
Sling	30%	1D8	

OTHER SKILLS—Move Quietly 50%, Spot Hidden Item 40%, Practical Joke 80%.

## PYTHON (very large snake)

Though not a mythical or legendary creature, the python does possess a number of legendary properties. Pythons have the ability to entrance their prey as do vampires, causing the victim to stand still until attacked. Determine the outcome by matching POWs on the resistance table. The victim may not parry or otherwise defend himself. If the victim resists the effects of the serpent's gaze, he need not defend himself again from the hypnotic gaze during that struggle with the python.

Characteristics		Average	
STR	3D6+12	22-23	Move 6
CON	2D6+6	13	Hit Pts: 16
SIZ	5D6	17-18	
POW	3D6	10-11	
DEX	2D6+6	13	
Weapon	Attack	Damage	
Bite*	40%	1D6	
Crush*	60%	2D6†	

\* There is a +20% chance to bite or to crush an entranced victim.

† If the crush attack succeeds once, the victim is totally enfolded in the coils of the serpent. The victim may have his weapon arm free to fight if he is not surprised and can roll DEX x 3 or less on D100. He cannot speak or cry for help. Each round of crushing does 2D6 damage—armor will help in resisting this, if any of the characters are weird enough to go trotting about in medieval plate. The victim also must successfully roll CON x 5 or less on D100, or he will fall unconscious.

ARMOR—2 point skin.

SKILLS—Move Quietly 90%, Hide in Cover 75%.

HABITAT—tropical forests.

## RAT PACKS

Rats may attack in packs. In each fight first find out how many rat packs are attacking and then relate the figure to the player. A reasonable attack might be 1D8 + 2 rat packs in one situation, and 1D3 in another—you will need to tailor your attacks. Tell the players how many are attacking, and then always allow the characters first attack. If a character happens to make his percentage with whatever weapon he has, then he kills a rat, and one pack scampers away in dismay, reducing the overall attack in the round.

Rats always attack second. Find the number of packs and multiply the figure by 5% to establish their current chance of a successful attack. A successful attack will do 1D3 points damage to a character. If the character is armored, the armor may absorb the damage of each attack individually.

When telling players about the horde of red-eyed rats meeping and gibbering across the floor, multiply the number of packs by 10 and give the players the total number of rats involved—there is no need to inform them that the number of rat packs is the only important element.

## SQUIDS, GIANT

This is a prototype squid. To make a whale-battler, add 1D6 of SIZ and STR for every two feet of span from tentacle-tip to tentacle-tip. The statistics are for a squid about four yards across.

Characteristics		Average	
STR	6D6	21	Move 4/10 swimming
CON	2D6+6	13	Hit Pts: 17
SIZ	6D6	21	
INT	2D6	7	
POW	3D6	10-11	
DEX	2D6+12	19	
Weapon	Attack	Damage	
Beak*	45%	1D10+ poison, potency equals CON	
Tentacle*	45%	1D6†	

\* The beak and the eight tentacles can attack simultaneously at up to eight different targets.

† If a tentacle strikes a foe, it will hang on. When a foe has been struck by two different tentacles, they will constrict him, giving him 4D6 points of damage per round. Armor will protect against this damage.

ARMOR—2 point skin.

SKILLS—Hide in Cover 70%.

HABITAT—salt water only; world-wide, but much prefers the cooler sub-surface waters, especially those closer to either pole.

## SKELETON, HUMAN

Animated skeletons are encountered in a very few legends of medieval times. Skeletons are fairly brittle, and damage easily with a heavy weapon. They remain relatively immune to impaling weapons.

Any weapon which hits a skeleton has a chance of destroying it equal to or less than the number of damage points rolled x 4 on D100. For example, if an axe hit a skeleton and did 8 points damage, there would be a 32% chance of destroying the skeleton by shattering it. Unless the skeleton is shattered, it remains undamaged. Impaling-type weapons do less damage, having only a damage done x 2 chance on D100 of destroying the skeletons. This includes firearms: a .45 revolver doing 10 points of damage to a skeleton will destroy the skeleton only on a D100 roll of 01-20. They may not be harmed otherwise.

Skeletons need triggering to be animated. The activating event may be an unadvised push of a button or the entering of a sacred room. Once set in motion, skeletons fight to the death. Roll individually for skeleton weapons.

Characteristics		Average	
STR	3D6	10-11	Move 8
CON	N/A	— — —	Hit Pts: 9
SIZ	3D6	10-11	
POW	3D6	10-11	
DEX	2D6+6	13	

roll 1D6	weapon	attack	damage	number appearing
1	sword	DEX x 4%	1D8+1	3D6
2	ax	STR x 4%	1D6+1	
3	flail	DEX x 3%	1D6	
4	mace	20%	1D6+2	
5	morning star flail	DEX x 2%	1D10+1	
6	sickle	DEX+STR%	1D6+1	

ARMOR—within a group they all wear the same 1D6 armor.

HABITAT—anywhere that magicians have worked.

## TIGER

Characteristics	Average	
STR 3D6+12	22-23	Move 10
CON 3D6	10-11	Hit Pts: 13
SIZ 3D6+6	16-17	
POW 3D6	10-11	
DEX 2D6+12	19	

Weapon	Attack	Damage
Bite*	45%	1D10+1D6
Claw*	70%	1D8+1D6
Ripping*†	80%	2D8+2D6

\* All felines get two claw attacks and one bite attack in a round. These must all be used against the same opponent.

† If the tiger hits a foe with both claws, it will hang on and rip with its hind legs from then on, and may continue to attack by biting as well.

ARMOR—2 point skin.

OTHER SKILLS—Move Quietly 75%; Hide in Cover 80%; Track 50%.

HABITAT—tropical jungles of the eastern hemisphere.

## VAMPIRE

Every campaign needs vampires. But there are so many conflicting stories about vampires and about their powers and abilities that it seems best to let the individual gamemaster determine which vampire facts in particular are true in their campaign and which legends are merely old wives' tales. The following guidelines are not meant to be hard and fast rules.

Vampires have all the traditional powers and problems imputed to them. The cross gives protection from a vampire. Vampires are twice as strong as a man. Once its hit points have been exceeded, the vampire will turn into smoke at the end of the melee round and regain CON at a rate of 1 point per melee round. A vampire can turn into smoke or mist at will. A vampire can change into a wolf or a bat. Vampire smoke will move at one movement unit per melee round. Vampires have no special powers in daylight, and may be unable to move abroad. Vampires may be forced to return to soil in which they originally were buried in order to pass the daylight hours.

However, if the vampire's hit points have been reduced *exactly* to zero, its head has been hit: the vampire will fall and cannot turn into smoke. Then a stake driven through its heart will kill for ever. One may also have to cut off the head, though this differs from legend to legend.

Characteristics	Average	
STR 3D6 x 2	20-22	Species move + 2
CON 2D6+2	13	Hit Pts: 12
SIZ 3D6	10-11	
INT 3D6	10-11	
POW 2D6+6	13	
DEX 3D6	10-11	
CHA 3D6	10-11	

Weapon	Attack	Damage
Touch*	50%	1D4+1D4
Bite†	50%	1D4

\* The touch of a vampire can reach through armor and attack a character's POW. If the vampire wins, the character loses POW.

† If the bite of a vampire penetrates armor, it drains 1D6 in STR (blood) from the victim per melee round. It will stay attached until the victim is dead or the vampire is destroyed.

ARMOR—usually none, but it can wear any available armor. The armor will not turn into smoke as does the vampire.

HYPNOTIC GAZE—if the vampire catches the glance of a character, it can attempt to control the character through a POW vs. POW roll on the resistance table. A roll of the target character's POW x 5 or less must be made on D100 to see if he was lucky enough to avoid the gaze of the vampire.

Unlike living creatures, vampires cannot regain POW after losing it by using magic or by the POW vs. POW combat also used by ghosts (*q.v.*). However their POW-draining ability removes POW from victims and transfers it immediately to the vampire's permanent POW, and increases it. In this way only the vampire restores POW. The victim of POW loss to a vampire will regenerate his own POW to its normal maximum in the usual fashion. A vampire's maximum POW is 21; further drain of POW will be lost to the vampire as well as to the victim.

HABITAT—wherever deals with Satan are made.

## WEREWOLF

There seem to be two types of werewolf, and either type could be used in play. Lon Chaney, Jr.'s *The Wolfman*, an old and well-known film, typifies the first: a normal human is cursed and occasionally thereafter turns into a monster, half-human and half-beast. The human may be unaware of his curse; if he is, he detests his fate (see also Robert E. Howard's *Wolfhead*). The second type of werewolf is the fiend who enjoys becoming a wolf and ravaging on human flesh. This type may transmute into a full-fledged wolf, rather than the half-human monster. It also has more control over its metamorphoses than the cursed-human type.

Either type can be damaged only by silver weapons or by fire.

Characteristics	Average	
STR 3D6 (x 2)	10-11 (22)	Move 8 (12)
CON 3D6	10-11	Hit Pts: 10-11
SIZ 3D6	10-11	
INT 3D6	10-11 (5-6)	
POW 3D6	10-11	
DEX 3D6	10-11	
CHA 3D6	10-11 (1)	

Weapon	Attack	Damage
Bite	30%	1D8+1D4

ARMOR—1 point skin.

OTHER SKILLS—Track by Smell 60%, Hide in Cover 50%.

HABITAT—wherever the full moon shines brightly.

## WOLF

Characteristics	Average	
STR 2D6+6	13	Move 12
CON 3D6	10-11	Hit Pts: 10-11
SIZ 3D6	10-11	
POW 3D6	10-11	
DEX 2D6+6	13	

Weapon	Attack	Damage
Bite	30%	1D8

ARMOR—1 point fur.

OTHER SKILLS—Tracking by Smell 80%; Spot Hidden Item 60%.

HABITAT—approximately the same ranges as cold and temperate-climate larger ruminants and herbivores.

Wolves may hunt in packs in the presence of herds of deer or elk; they will as often hunt singly or in family pairings. They are normally shy, and verified attacks on healthy humans have been rare to non-existent.

## WRAITHS

Wraiths are a special form of ghost, the creation of which was prompted by the overwhelming frustration and hate of the deceased at his or her time of death. Wraiths are malignant to all forms of life, but are friendly to the undead. Wraiths, like ghosts in general, should be hand-crafted, and rarely have POWs less than 13.

Wraiths live on the ethereal plane, and this gives them special powers and vulnerabilities. Wraiths are vulnerable to magic and their POW acts like CON in dealing with a magical attack. If a wraith loses all its hit points, it dissolves and cannot reform for at least a week. It may not be able to reform at all.

In an attack, the wraith matches its POW vs. the victim's CON on the resistance table. If the victim fails to resist, he loses characteristic points from his STR, INT, or his CON, depending upon the type of wraith encountered, but always equal in number to the current POW of the wraith. A wraith can attack in this manner only once per victim. If the victim's score in a characteristic is reduced to below 1, the victim dies. If the victim survives the initial attack, the wraith must attack the victim's POW on all subsequent attacks. If such an attack is successful in a round, the victim loses D6-1 (0-5) points POW; if the victim attacks back successfully, the wraith loses D6-1 (0-5) points of POW.

## ZOMBIE

Though everyone knows what zombies are like from the movies, there are not many stories written about them. Zombies are almost immune to weapons which impale (including firearms), although such weapons will further damage the zombie's appearance. Any hit by an impaling weapon does 1 point damage to the creature's CON. All other weapons do only half the normally-rolled damage, and the zombie literally must be hacked apart before it will cease its deeds. A few spells and sub-

stances may deactivate zombies, but these are best left to the individual referee.

Like skeletons, the 1 point of POW motivates the entity. In the case of zombies, the POW is supplied by the spell creating them. The spell-caster directs them: zombies have no motivation of their own.

The STR and CON of a zombie are multiplied by 1.5 as part of the spell—the zombie is a clumsy opponent, but a real damage-doer if it hits you. Zombie programming is sufficient to let it hit at its DEX x 5 or less on D100, but it rarely parries at more than half that. Zombies often have two-handed weapons, and they can wear any type of armor.

Characteristics	Average	
STR 3D6 x 1.5	15-17	Move 6
CON 3D6 x 1.5	15-17	Hit Pts: 13-14
SIZ 3D6	10-11	
POW 1	1	
DEX 2D6	7	

Weapon	Attack	Damage
Maul	35%	2D8+1D6

ARMOR—as provided, usually 2-point leather.

# BIBLIOGRAPHY

Anything printed during the 1920's will provide ideas for a referee. The magazines of the time (*National Geographic*, *American Mercury*, *Harper's*, the newly-born *Time*, *Saturday Evening Post*, etc.) deliver insights into the daily life of Americans which no history book could evoke. Referees will find dozens or hundreds of brand names and products to fill out their own imaginings about the era, as well as more indirect information (for instance, the great number of column inches devoted to laxatives may reveal something about American diets of the day). Newspapers record exact data for particular cities or geographic areas, especially about prices—an area which national magazines do not cover, since product pricing is done by region.

The following books were useful or were suggestive in putting this book together. Narrative histories of the period deliberately have been ignored in this list, since they are so easily obtained, but if you must have a starting point, try Allen's *ONLY YESTERDAY*.

Ballinger, *LOST CITY OF STONE: THE STORY OF NAN MADOL*. Simon & Schuster, New York, 1978.

Bidwell, *BRASSEY'S ARTILLERY OF THE WORLD*. Bonanza Books, New York, 1979.

Brown and Jeffcott, *ABSOLUTELY MAD INVENTIONS*. Dover Books, New York, 1970.

ENCYCLOPEDIA BRITANNICA, 11th edition, London, 1908.

Fort, *WORKS*. Tiffany Thayer, ed.

Gardner, *FADS & FALLACIES IN THE NAME OF SCIENCE*. Dover Books, New York, 1957.

Hawkes, *ATLAS OF ANCIENT ARCHAEOLOGY*. McGraw Hill, New York, 1974.

MacDougall, *HOAXES*. Dover Books, New York, 1958.

McGraw Hill ENCYCLOPEDIA OF BIOGRAPHY. McGraw Hill, New York, 1973.

OFFICIAL GUIDE OF THE RAILWAYS & STEAMSHIP NAVIGATION LINES OF THE U.S. National Railway Publication Co., New York, 1915.

Owen, *BRASSEY'S INFANTRY WEAPONS OF THE WORLD*, Bonanza Books, New York, 1979.

OXFORD ECONOMIC ATLAS, various editions, Oxford U. Press.

Post, *AN ATLAS OF FANTASY*. The Mirage Press, Ltd., Baltimore, 1973.

RAILWAY YEAR BOOK, New York, various years.

Reader's Digest, *NATURAL WONDERS OF THE WORLD*. Reader's Digest, Pleasantville, New York, 1973.

—, *THE WORLD'S LAST MYSTERIES*. Reader's Digest, Pleasantville, New York, 1979.

SEARS, ROEBUCK & CO. 1909 CATALOG. Selected pages reproduced by Ventura Books, Inc., New York, 1979.

SEARS, ROEBUCK & CO. 1923 CATALOG. Selected pages edited by Joseph J. Schroeder, Jr., DBI Books, Inc., Northfield, Illinois, 1973.

Service and Bradbury, *MEGALITHS AND THEIR MYSTERIES: A GUIDE TO THE STANDING STONES OF EUROPE*. Macmillan, New York, 1979.

Trevor-Roper, *HERMIT OF PEKING: THE HIDDEN LIFE OF SIR EDMUND BACKHOUSE*. Knopf, New York, 1977.

WORLD ALMANAC, various years.

Wallechinsky and Wallace, *PEOPLES' ALMANAC*. Doubleday, New York, 1975.

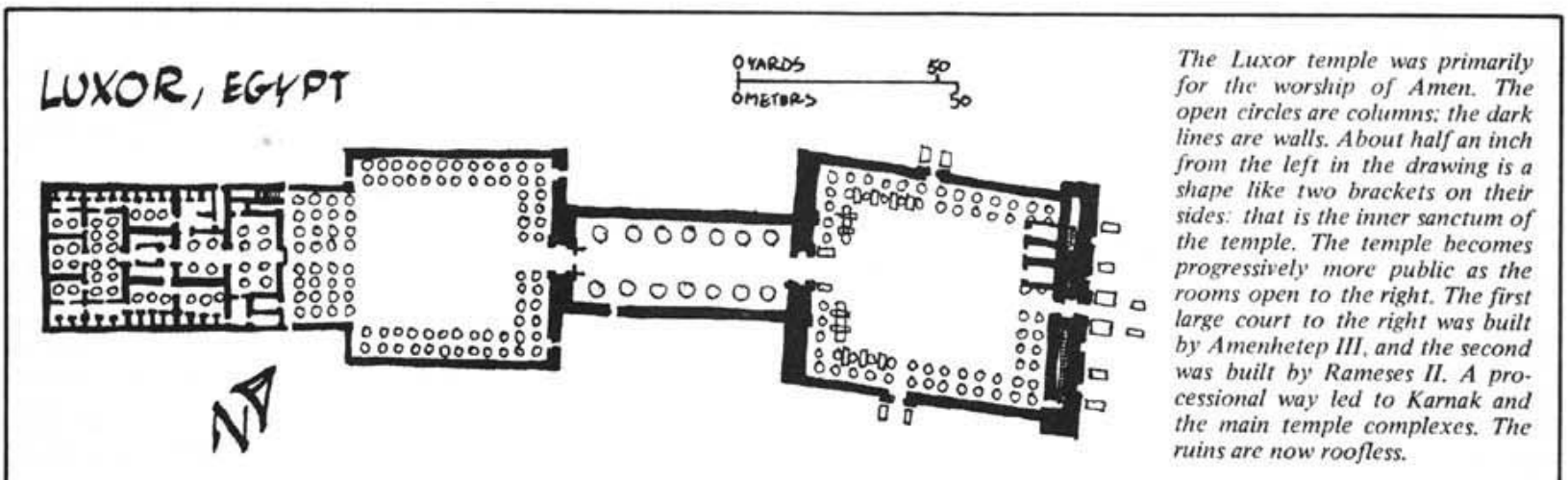

The Luxor temple was primarily for the worship of Amen. The open circles are columns; the dark lines are walls. About half an inch from the left in the drawing is a shape like two brackets on their sides: that is the inner sanctum of the temple. The temple becomes progressively more public as the rooms open to the right. The first large court to the right was built by Amenhetep III, and the second was built by Rameses II. A processional way led to Karnak and the main temple complexes. The ruins are now roofless.

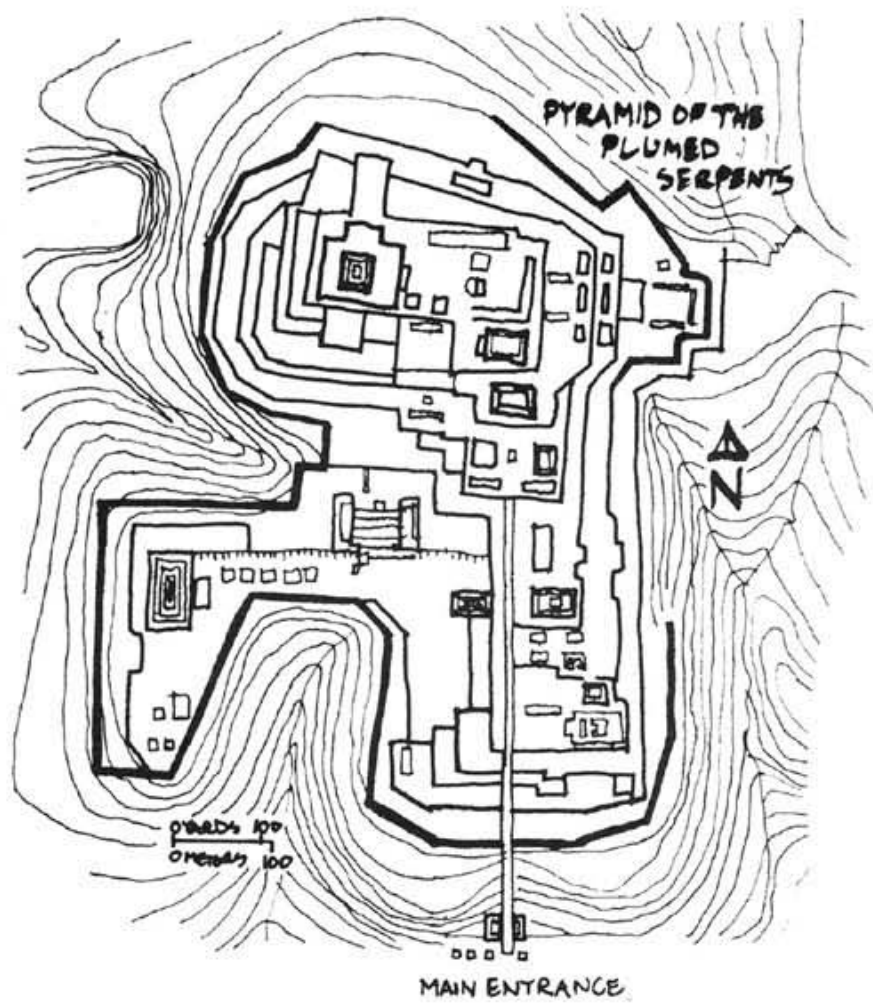

### XOCHICALCO, MEXICO

The main structures were built and used during the last half of the first millenium. This is a hilltop site, with many descending terraces. The main pyramid is the highest point of the complex. The main entrance is the long avenue which starts at the bottom of the drawing. There is a ball court to the left of the top of the entrance avenue, as well as a series of small altars. All over the small city are underground ways and rooms, the purposes of which are conjectural. Xochicalco is an excellent example of the sort of lost city that adventurers might stumble across. The actual site is in Morelos, south of Mexico City.

The Pan-P'o site dates from about 4500 B.C., and can be taken by a referee as typical of small primitive villages. There are slightly more than a dozen circular homes outlined by their remaining foundations. There are many storage wells (the smallest circles shown, and many not shown) which were dug into the ground as far as 20 feet, and were lined with burned clay as protection. The site is bisected by a ditch.

### PAN-P'O-TS'UN, CHINA

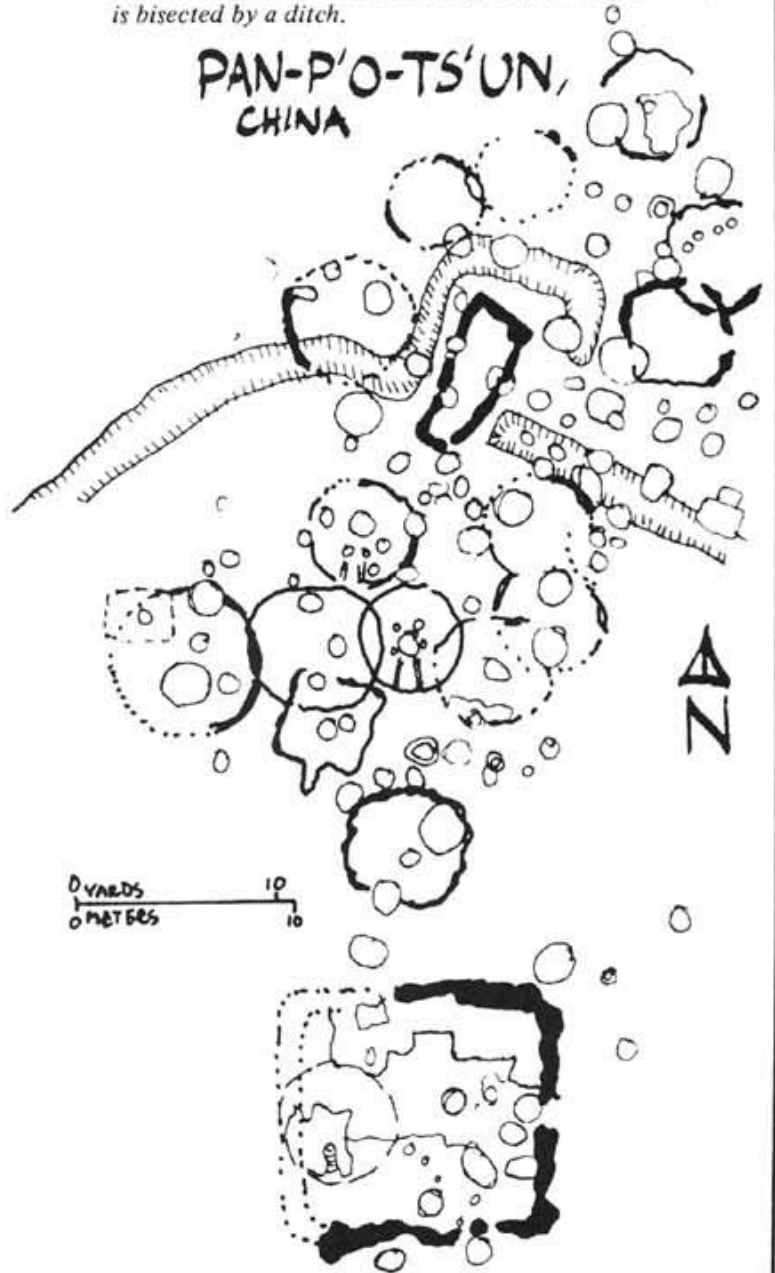

The Moundbuilders of the Mississippi Valley may have been influenced by the brilliant Mexican cultures to the south, but they were indigenous peoples, as eyewitness reports in the 16th and 18th centuries make clear. Like the early Nile cultures, the villagers worked land which was annually renewed by floods, and the people were led or ruled by a priestly class obsessed with death. Every pyramid originally had some sort of sacred temple or religious structure atop, made of wood and thatch. In the example of the Moundville structures, they appear to be grouped around an open ceremonial center. Note that one mound is circular, not pyramidal.

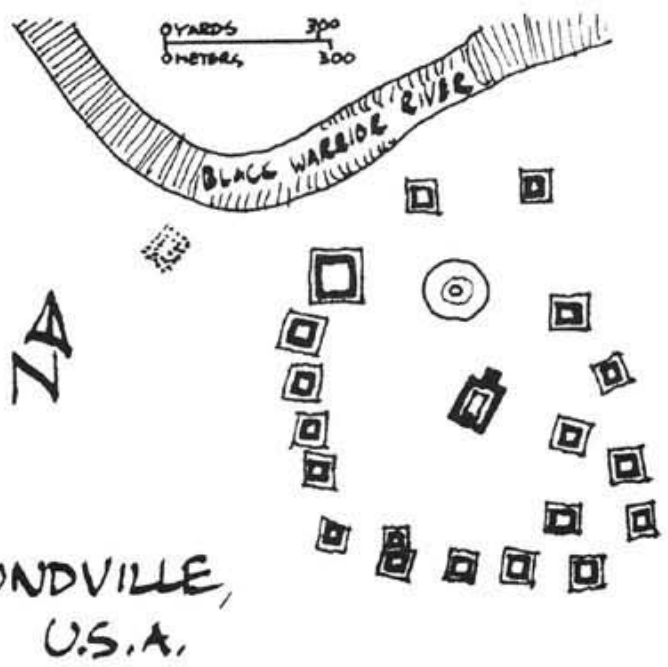

### MOUNDVILLE, U.S.A.



# NOTES



Slightly out of period, the Hindenburg plan is a model of the kind of airship that an arch-villain (or an arch-hero) might plan and build. In place of passenger cabins might be hangars for special aircraft which take off and land by cable and winch, chart rooms, extra-powerful telescopes, electroscopes for detecting approaching enemies and storms, perhaps giant loudspeakers with which to broadcast to the ground, and so on. (Be sure to load your gas cells with helium, not hydrogen.) Given pre-planning, such airships were perfectly capable of soaring thousands of miles, or even around the world. Bon voyage!

The ship is covered by rubberized fabric, wire netting, and cable bracing, then by longitudinal stringers under the outer layer of fabric.

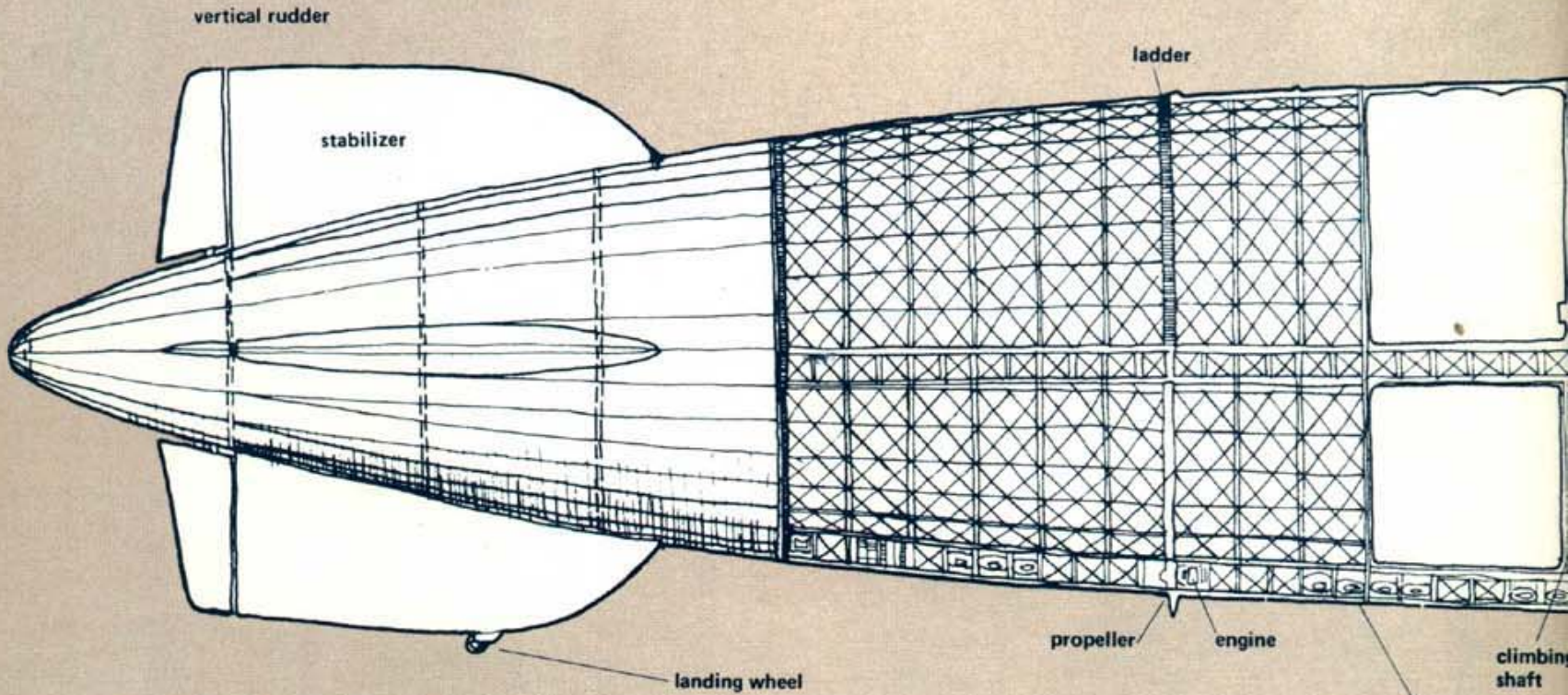

Side View, HINDENBURG

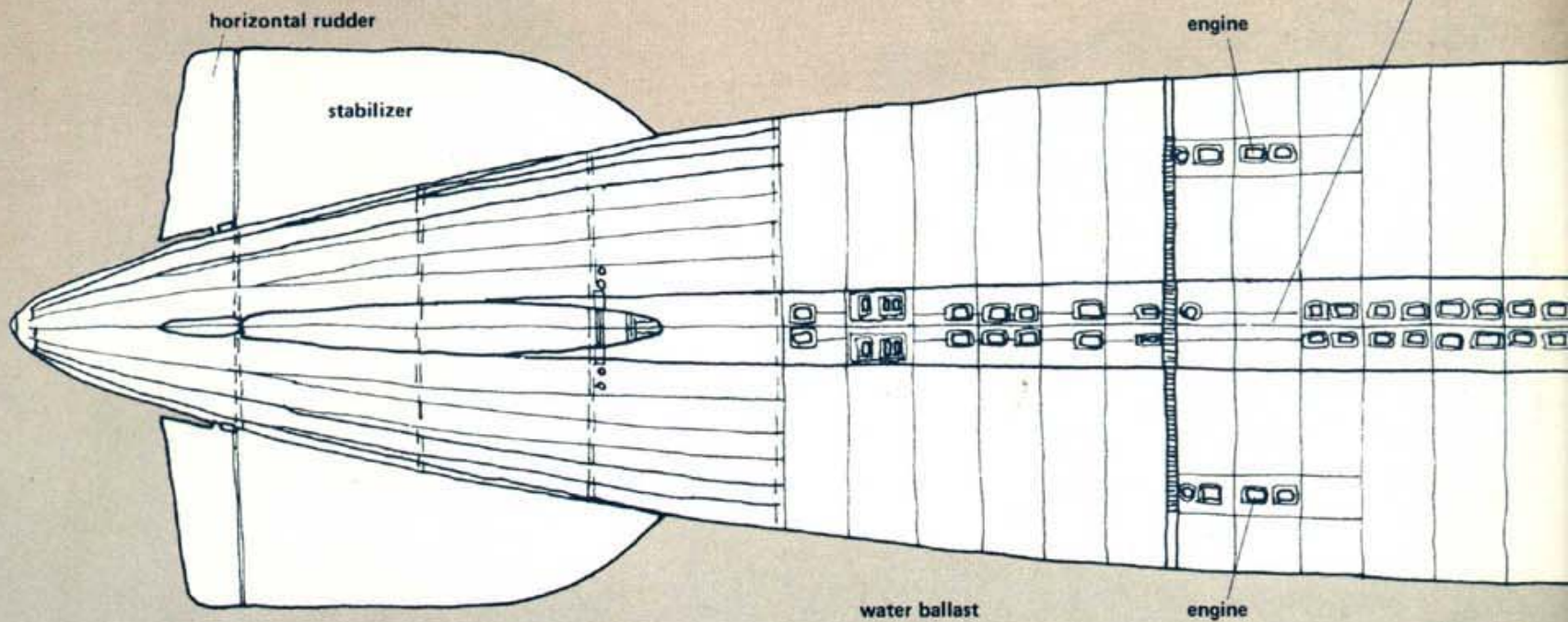

Bottom View, HINDENBURG