

**Tickets-of-Leave** are small self-contained additions to the **Convicts & Cthulhu** setting for Lovecraftian roleplaying in the early penal colonies of Australia. Each includes a selection of game elements which can either be used collectively as a thumbnail sketch of a scenario, or can be used in isolation to provide pieces that enhance a scenario of your own invention.



# Convicts & CTHULHU

## TICKET of LEAVE #14

### Hark, Now Hear The Sailors Cry

#### CREDITS

Ticket-of-Leave #14 is written by Matthew Ruane; original artwork by Reuben Dodd. Copyright © 2019. Published by Cthulhu Reborn Publishing.

([WWW.CTHULHUREBORN.COM](http://WWW.CTHULHUREBORN.COM))

The **Convicts & Cthulhu** setting is published by Cthulhu Reborn Publishing and is available via RPNOW and DrivethruRPG as a "Pay-What-You-Want" title.

This PDF uses trademarks and/or copyrights owned by Chaosium Inc/Moon Design Publications LLC, which are used under Chaosium Inc's Fan Material Policy. We are expressly prohibited from charging you to use or access this content. This PDF is not published, endorsed, or specifically approved by Chaosium Inc. For more information about Chaosium Inc's products, please visit [www.chaosium.com](http://www.chaosium.com).

## Introduction

One of the earliest industries to gain a foothold after Europeans first settled the Australian continent was the maritime hunt for whales and seals. In the late 18th and early 19th Centuries, the demand for resources derived from slaughtered whales was well-established. Most valuable was the whale blubber which could be melted down to make oil for lamps, several types of lubricants, candles, and also be used as the base for products such as perfume or soap. Whale bones (also called

baalen) were most famously used for ladies' corsets but were also a component in the production of umbrellas, whips, and hoops for ladies' skirts. With so many valuable whale-derived products, catching a large whale was a substantial windfall to a hunting ship's captain and crew. At the same time (and frequently in the same places), seals were hunted, primarily for their pelts but also for their blubber. Pelts could be made into furs for winter clothing as well as leather for shoes and other uses; seal blubber could be rendered into oil in much the same way as whale blubber.





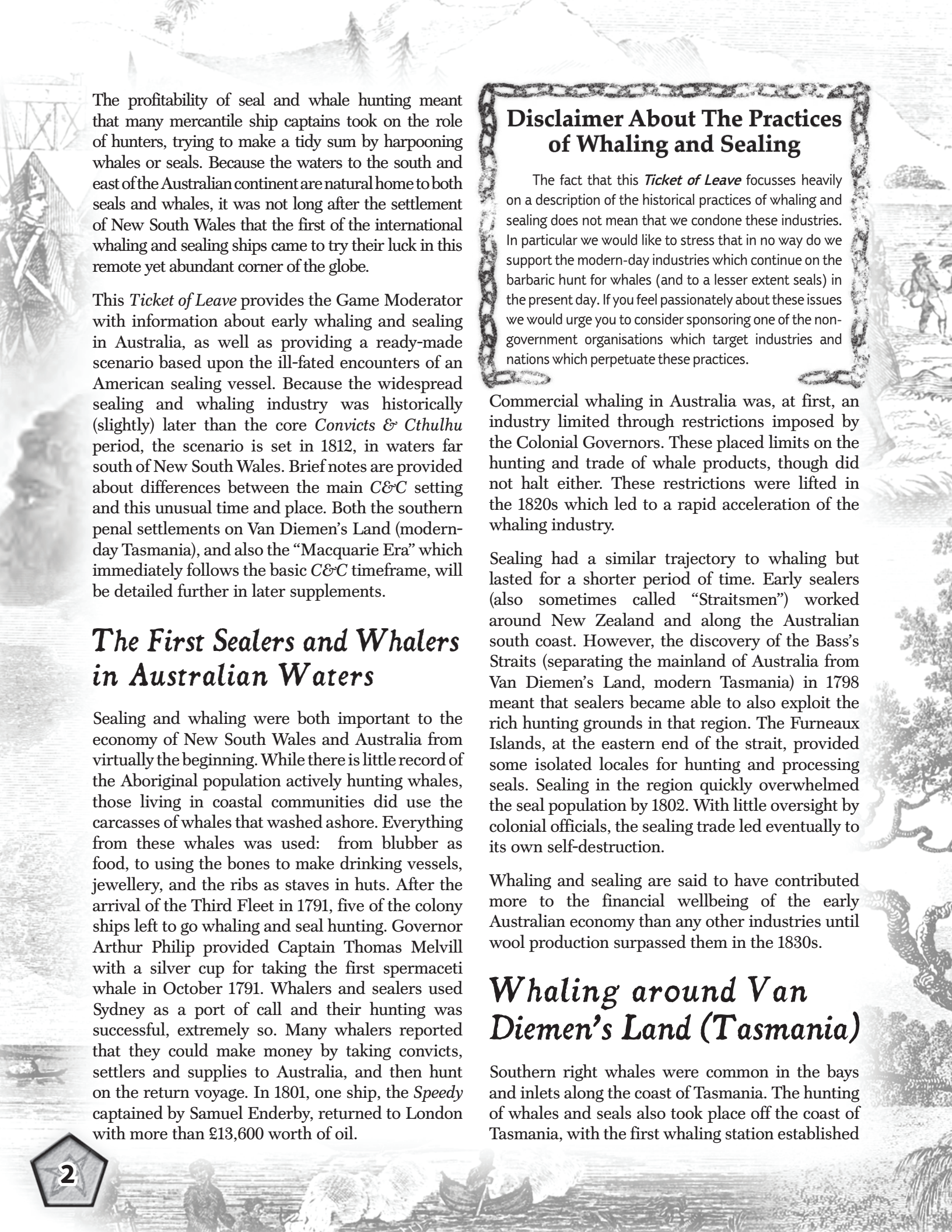

The profitability of seal and whale hunting meant that many mercantile ship captains took on the role of hunters, trying to make a tidy sum by harpooning whales or seals. Because the waters to the south and east of the Australian continent are natural home to both seals and whales, it was not long after the settlement of New South Wales that the first of the international whaling and sealing ships came to try their luck in this remote yet abundant corner of the globe.

This *Ticket of Leave* provides the Game Moderator with information about early whaling and sealing in Australia, as well as providing a ready-made scenario based upon the ill-fated encounters of an American sealing vessel. Because the widespread sealing and whaling industry was historically (slightly) later than the core *Convicts & Cthulhu* period, the scenario is set in 1812, in waters far south of New South Wales. Brief notes are provided about differences between the main *C&C* setting and this unusual time and place. Both the southern penal settlements on Van Diemen's Land (modern-day Tasmania), and also the "Macquarie Era" which immediately follows the basic *C&C* timeframe, will be detailed further in later supplements.

## The First Sealers and Whalers in Australian Waters

Sealing and whaling were both important to the economy of New South Wales and Australia from virtually the beginning. While there is little record of the Aboriginal population actively hunting whales, those living in coastal communities did use the carcasses of whales that washed ashore. Everything from these whales was used: from blubber as food, to using the bones to make drinking vessels, jewellery, and the ribs as staves in huts. After the arrival of the Third Fleet in 1791, five of the colony ships left to go whaling and seal hunting. Governor Arthur Philip provided Captain Thomas Melville with a silver cup for taking the first sperm whale in October 1791. Whalers and sealers used Sydney as a port of call and their hunting was successful, extremely so. Many whalers reported that they could make money by taking convicts, settlers and supplies to Australia, and then hunt on the return voyage. In 1801, one ship, the *Speedy* captained by Samuel Enderby, returned to London with more than £13,600 worth of oil.

### Disclaimer About The Practices of Whaling and Sealing

The fact that this *Ticket of Leave* focusses heavily on a description of the historical practices of whaling and sealing does not mean that we condone these industries. In particular we would like to stress that in no way do we support the modern-day industries which continue on the barbaric hunt for whales (and to a lesser extent seals) in the present day. If you feel passionately about these issues we would urge you to consider sponsoring one of the non-government organisations which target industries and nations which perpetuate these practices.

Commercial whaling in Australia was, at first, an industry limited through restrictions imposed by the Colonial Governors. These placed limits on the hunting and trade of whale products, though did not halt either. These restrictions were lifted in the 1820s which led to a rapid acceleration of the whaling industry.

Sealing had a similar trajectory to whaling but lasted for a shorter period of time. Early sealers (also sometimes called "Straitsmen") worked around New Zealand and along the Australian south coast. However, the discovery of the Bass's Straits (separating the mainland of Australia from Van Diemen's Land, modern Tasmania) in 1798 meant that sealers became able to also exploit the rich hunting grounds in that region. The Furneaux Islands, at the eastern end of the strait, provided some isolated locales for hunting and processing seals. Sealing in the region quickly overwhelmed the seal population by 1802. With little oversight by colonial officials, the sealing trade led eventually to its own self-destruction.

Whaling and sealing are said to have contributed more to the financial wellbeing of the early Australian economy than any other industries until wool production surpassed them in the 1830s.

## Whaling around Van Diemen's Land (Tasmania)

Southern right whales were common in the bays and inlets along the coast of Tasmania. The hunting of whales and seals also took place off the coast of Tasmania, with the first whaling station established



near Hobart Town in 1803. Robert Knopwood, a clergyman and magistrate, reported in his diary for July 1804, that “we passed so many whales that it was dangerous for the boat to go up the river (Derwent) unless you kept very near the shore.”

As the fledgling industry developed, Van Diemen’s Land became the centre of whaling in the Antipodes due to its location near Pacific whaling grounds, with Hobart and Sydney being the principal ports of whaling vessels. Whalers in Bass’s Straits, far from the government centres in Hobart and Sydney, often lived wild and lawless lives.

## Sealing in the Antipodes

Sealing off the coast of Tasmania dates back to before the founding of the European colonies there. By 1798, reports presented to colonial authorities in Sydney from George Bass and Matthew Flinders, remarked on sealing taking place in Bass’s Straits and around the Furneaux Islands. The main seal species hunted was the Tasmanian Fur Seal, with males about 7’ long, and females about 5’ long. Seals were harvested for their skins and oil, both of which had a variety of purposes. By 1803, Sydney merchants John Palmer, Henry Kable, James Underwood, Simeon Lord and Robert Campbell become involved in the sealing trade and began to post announcements in the *Sydney Gazette* seeking men to work as sealers. Much of the product was exported to China or England.

Thousands of seals were killed each year, so many that by 1806 there were complaints that seal numbers were visibly declining. “Since I took command, 16,000 gallons of oil and 27,846 seal skins” had passed through Sydney in May 1803 according to Governor King. In an effort to curb the unregulated slaughter of seals, King tried several measures to reduce the trade.

- Firstly, King banned whalers and sealers from using Sydney as port or depot. No aliens could settle in the territory without the governor’s permission; this was aimed at the increasing number of American and French straitsmen in the area.
- Also, because many of the early sealers were American, King tried to curb the practice by creating a temporary ban on foreign vessels in the waters between New South Wales and Van Diemen’s Land.

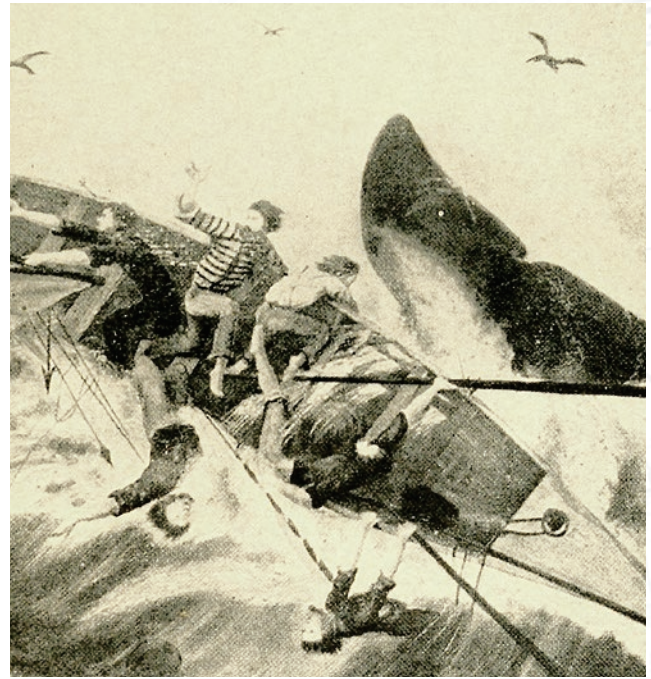

Despite King’s efforts, the mass slaughter of seals continued unabated. This over-hunting meant that sealing as a viable trade was finished by the late 1830s.

## The Life of a Whaler or Sealer

Seafarers who took a job on a whaling and/or sealing vessel led a harsh life. Herman Melville’s famous novel *Moby Dick* describes the whaling industry approximately 50 years after the time of *Convicts & Cthulhu*, but many of the same practices and challenges are common to those who hunted the waters of Australia.

## Temporary Land-Based Settlements

Whalers in Australian waters often established land-based camps to render the blubber into oil. Over the winter months, teams of whalers would work to fill casks of oil and in the spring, their ships would return to pick up the men and the refined products. Some settlements would eventually become permanent, but many others were extremely temporary.

Sealers likewise created temporary camps on shore as places to skin and otherwise process their kills.





Life among the sealing communities based ashore was often dangerous, as many of the sealers were escaped convicts or other dangerous individuals. Many of the local Aboriginal communities were exploited by the sealers, who sometimes took their women as concubines and “wives” while employing the men to help with the seal hunt.

The ashore sealer communities were usually run by groups of men who built temporary shelters, usually huts. These were often built from salvaged materials, along with sails, tarps and sealskins. Historical and archaeological evidence indicates that, if there was a standard construction method, the huts were about 20 feet by 10 feet and consisted of a hearth, a storage area, and a bedstead. The walls were covered with skins of seals and local grasses, while the wooden framework came from ship stores.

According to historical evidence from sites used for Antipodean sealing, these groups usually comprised about 12 men, who spent their time both hunting and rendering their kills. To aid in the rendering, tryworks were created to render the blubber and fat of seals into oil to be casked for shipment. Tryworks usually consisted of two iron trypots set atop a fire to heat blubber to render the fat for oil. Casks would be then filled, and occasionally to aid in the process of producing new casks, a small cooper might be employed to keep a sufficient quantity of casks available.

## The SS *Industry*: A Typical Whaling or Sealing Vessel

Game Moderators who wish to run *Convicts & Cthulhu* adventures involving sealing or whaling will eventually have a need for a ready-made example of a typical whaling/sealing ship. The fictional *SS Industry*, described below, can serve that purpose: it is also the ship which features in the scenario section of this *Ticket of Leave*.

This fictional vessel is based in part on the *Essex*, an American whaler from Nantucket, launched in 1799. She later becomes the source for Melville’s *Moby Dick*, after the *Essex* was sunk by a sperm whale in 1820. The *Industry* is also part-based on the sloop *Essex Junior*, that began her life as whaling ship for Samuel Enderby and Sons, before being captured by the Americans in 1813.

## Investigator Occupations for Sealing/Whaling Vessels

It is quite possible that investigators in your *Convicts & Cthulhu* game could come from a background of sealing or whaling in Australian waters. More ambitiously, a Game Moderator might even consider a campaign featuring the ongoing exploits of a sealing or whaling vessel as it encounters peril and Mythos dangers at sea. For either of those options, the expanded list of professions found in *Ticket of Leave #5 (The Damned & The Degenerate)* is helpful. This supplement is available on DriveThruRPG or direct from the [download page of Cthulhu Reborn](#).

From the *Ticket of Leave #5* professions list, the following are of particular relevance to maritime characters and campaigns of a mercantile variety (page numbers refer to the *ToL#5* PDF): Down-On-Luck Craftsman (p. 8), Labourer (p. 10), Doctor (p. 11), Marine (p. 14), Naval Officer & Naval Rating (p. 16), Ship’s Purser (p. 17), Merchant (p. 18), Merchant Sailor (p. 19), Sealer/Whaler (p. 20) and Supercargo (p. 22).

## THE SHIP

The *Industry* is an American brig-sloop purpose-built as a whaler. She has a crew of 26 including 4 officers (Master, and First through Third Mates). Because of the risk of privateers during the ongoing war with England (see the box on page 14), she has been armed with eight 18-pounder carronades. These lightweight guns need only a small crew, are devastating at short range, and can easily defend the ship from many armed privateers.

Game Statistics for the 18-pounder carronade: Skill Artillery, Damage: 4d10/1 yard, Base Range: 400 yards, Rate of Fire: 1/5 rounds, Bullets: Separate, Malfunction: 95. The carronade is 3 ft. 3 in. long, and weighs 1,176 lbs. including its carriage.

There is enough ready powder and cannonballs on the deck for eight rounds to be fired (roughly one per original gun). Belowdecks are more barrels of powder and cannonballs.

## CREW OF THE INDUSTRY

Aboard the ship, the Master (or Captain) has complete control over the crew, the ship and its operations. The ship also has three Mates, from First to Third, and they not only help to carry out the Master’s orders, but also each commands





a whaleboat (see nearby box) during the hunt. Boatsteerers and Harpooners crew the whaleboats and have more freedom than the regular crew. Beneath them are Mechanics, such as blacksmiths, coopers, carpenters and the cook, who stayed behind when the crew went out to hunt whales. Finally, the Foremast Hands (Crewmen) are the ones who clean the vessels, maintain the sails, and row the whaleboats. Greenhands are the least experienced crewmembers, generally looked down upon by the rest of the crew.

## PASSENGERS

While most of the personnel aboard the *Industry* are involved in the whaling or sealing trade, the ship also has two small cabins in Steerage which can be used to house passengers. These are most likely to be people who have paid the Master to be transported on one of the legs of its travels.

In the event that the *Industry* encounters a British vessel at sea, the Master might “request” that passengers on the British ship transfer to the *Industry* — valid under a letter of marque that allows the capture of vessels (see the box on page 14). Passengers brought to the *Industry* in this fashion may be housed in the passenger cabins (if cooperative or well-to-do), or forced to share one of the Mates’ cabins, or even obliged to bunk in much less comfortable quarters with the ship’s mechanics or foremast hands.

Overall the ship has a maximum total capacity of 34 crew and passengers.

## DECK PLAN OF THE INDUSTRY

The general layout of the *Industry* is depicted in the plans on page 16. There are a number of key locations:

**The Master’s Cabin:** a stateroom at the rear of the ship. The Master’s cabin is usually simply appointed with a sofa, chairs, bed and perhaps a small desk. A table of some sort would also be used to host meals. It is also likely to contain maps and charts, as well as the logbook kept by the Master.

**The Mates’ Cabins:** smaller cabins at the stern of the ship where the ship’s First, Second, and Third Mates sleep. These are likely to contain sea chests holding the sailor’s worldly possessions. Mates usually do not dine in their cabins but instead at the Master’s table.

## Whaleboats

Whaleboats were designed to get close enough to a whale for the harpooner to manually hurl a harpoon to kill the massive creature. Whaling ships usually carry three to five of the whaleboats swinging from davits. Because some were lost in the hunt, vessels often have one to two spares carried on the deck. Each whaleboat is pointed at both ends, about 30 feet long and 6 feet wide. Most are equipped with a mast, sails, and rudder, and all carry oars and emergency paddles. The oars are extra-long, at least 16 feet in length, to propel the boat through the seas and to tow the whale towards the parent vessel. Whaleboats are therefore quite speedy and easy to repair due to their simple design.

The whaleboats usually have a crew of six: a boatsteerer who handled the rudder, a harpooner, and four rowers. The boat also has two wooden tubs filled with approximately 900 feet of line, anywhere up to five harpoons, some lances used to actually kill the whale once harpooned, axes or hatchets for emergencies, a wooden keg of water, a bailing bucket known as a “piggin,” a small keg with supplies (food, tinder, flint and steel), a compass, a float and additional buoys to keep the whale from sinking too easily, an anchor, and something called a fluke spade, to cut a hole in the whale’s line so the carcass can be towed back to the ship.

The *Industry* carries three whaleboats and two spares. One whaleboat may be found on divots on each side of the ship, with the third hanging from the rear of the ship. The spares are stored amidships atop one of the cargo hatches leading below deck.

**Steerage:** The boatsteerers and more skilled members of the crew have bunks in steerage, located in the middle of the ship. They tend to eat meals in the main cabin after the captain and the mates have finished.

**Cookhouse (Kitchen):** The kitchen is a small abovedeck structure in the centre of the ship. This space is filled with traditional shipboard rations: greasy pork, salted beef and horse, hard biscuits, small kegs of molasses, bags of beans, rice and some purple South American potatoes. Barrels of fresh water are also stored in the kitchen space, with additional supplies in the hold.

**The Hold:** If successful in their hunt, the hold of the whaling/sealing ship will be filled with barrels of oil



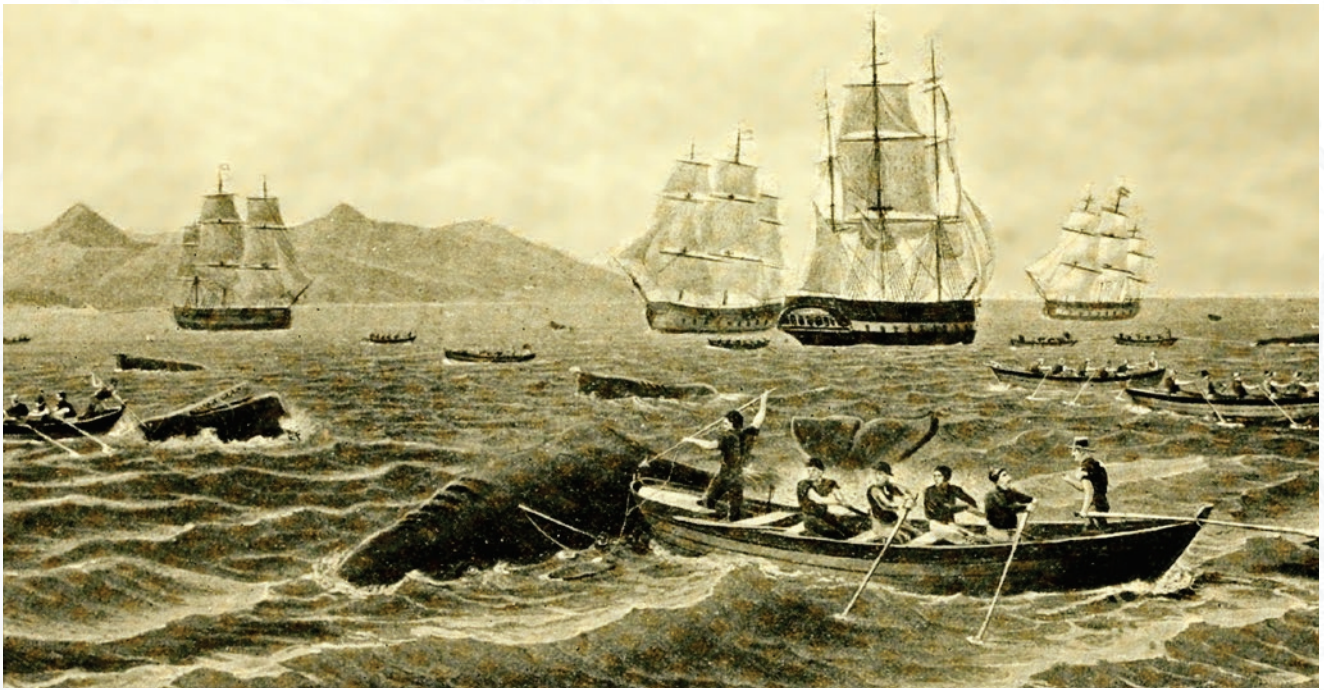

in its hold, as well as the equipment necessary to process caught whales and/or seals. This could be up to 90 barrels of oil. The hold is also likely to contain piles of seal skins and/or whale bones, in a chaotic array waiting to be sorted. The smell in the hold is overpowering to those unfamiliar with the trade.

**The Forecastle (Fo'c'sle):** The foremast hands sleep in the forecandle under the bow of the ship in narrow bunks that line the walls. Lacking any sort of furniture, the men use their sea chests for seating and as impromptu tables. Any remaining crew sleep in hammocks. In fair weather, the crew ate on the main deck, or below decks in foul weather.

## Scenario: Hark, Now Hear the Sailors Cry

This scenario is set in November, 1812 and takes place mostly in Bass's Straits – the stretch of water directly to the north of Van Diemen's Land, separating it from the Australian mainland. Because this time-period and geographical setting are a little different to the normal *Convicts & Cthulhu* core setting, a summary handout is provided to give the Game Moderator and players the necessary historical and regional information to play the scenario. This may be found on page 15.

*Hark, Now Hear the Sailors Cry* was run at GenCon Indy 2019 in a slightly modified format.

## Gamemaster's Introduction

This adventure concerns itself with the discovery of a mysterious, possibly derelict, American whaling ship in the region of Bass's Straits some 50 miles north-east of the permanent outpost at Port Dalrymple on Van Diemen's Land. The vessel has not responded to hails from several passing ships. The authorities at Port Dalrymple are beginning to worry that some terrible calamity has claimed the whaler, or perhaps that the abandoned American ship is part of some larger military plan. To investigate the situation, they have hastily gathered together a mixed crew of sailors and convicts – the Investigators – to approach the eerily silent vessel, locate any crew or passengers, and secure any cargo carried by the ship. Because of the state of war that exists currently between England and America, this trip is being treated as one of capturing an enemy ship, and accordingly the Investigators are given the requisite papers.

The scenario begins in Port Dalrymple with the Investigator party being assembled, provisioned, and hastily briefed about their mission. The majority of the action, however, plays out in the waters of Bass's Straits and on some of its smaller islands.

## The Truth of the Matter

The *Industry* is an American whaling vessel homeported in Kingsport, Massachusetts. She is an armed whaler set to hunt in the Pacific Ocean,



but the captain has also acquired a letter of marque which also allows him to “hunt” British ships.

The captain of the *Industry* is one Ebenezer Marsh, a successful sailor who served in the American Revolution and acquired his own ship in 1799. His First Mate is Amaziah Gardner of Nantucket; Second Mate is Jethro Clark of Marblehead; Third Mate is Edmund Perkins of Kingsport.

About a month ago, the *Industry* left Valpariso, Chile after taking on fresh water and food, as well as acquiring maps and charts necessary for travel through the South Pacific Ocean. Their voyage into the Pacific proved eventful, with the ship first encountering an armed British whaler, from which it was obliged to flee, then a succession of other hostile British ships. Because of the official state of war between America and Britain, Marsh soon came to suspect that a far more fatal encounter with a Royal Navy vessel might not be far off.

Seeking to effect some repairs from the skirmishes, and to lay low from the British for a time, the *Industry* set sail for the Society Islands (or the *Îles de la Société*, part of modern-day French Polynesia). They soon discovered an out-of-the-way and previously unexplored islet in the leeward chain of the Society group (one of the islands collectively called the *Îles sous-le-Vent*). This was a perfect place to undertake repairs, and also for Marsh to give his crew some much-needed shore leave.

## THE CONCUBINES

Unknown to the crew of the *Industry*, the native Polynesian islanders of this remote place are tainted, having interbred with Deep Ones for as long as living memory. The islanders had long been converted to the worship of Mother Hydra believing her to be a fertility goddess who increases their harvests and catches from the sea. The islanders managed to keep their secrets well hidden, presenting the visiting Americans only the most human-looking of their women — this group included several stunningly beautiful Deep One Hybrids.

At the end of their stay on the island, the officers of the *Industry* voted to take four of these beautiful Polynesian girls (Deep One Hybrids) as concubines, bringing them onto the ship. While originally hesitant to allow women aboard, once Marsh was promised his own concubine (another young Deep One Hybrid),

## When Was Bass's Straits Discovered?

It should go without saying that the Aboriginal peoples of Australia knew about the geography of the southern coastline of Australia long before Europeans arrived. Indeed, some 40,000 years ago they crossed from mainland Australia into Tasmania via a land bridge that linked the two together in the region that is now the eastern end of Bass Strait.

The first European to detect the existence of the strait was likely to have been the Dutchman Abel Tasman, who charted much of the coastline of Tasmania in 1642. Independently, the strait was discovered and entered by James Cook in 1770, during his voyage on the *Endeavour*. At the time of the discovery, Britain was in the grip of one of its many periods of intense rivalry with France, and there was great importance placed on ensuring that news of new discoveries did not reveal strategically important information to the Gallic foes. Thus, Cook's discovery of the strait was shrouded in secrecy: it was masked in his journal by a riddle and on his navigational charts by a fake stretch of coastline that joined Tasmania to the mainland at a fictional point named Point Hicks.

After the European settlement of New South Wales, there were further voyages of discovery around the coastlines of Australia. In 1798–99, explorer Matthew Flinders led an expedition to circumnavigate Tasmania (Van Diemen's Land), comprehensively proving that it was an island. The ship's surgeon on this voyage was one George Bass, after whom Flinders suggested that the strait between Australia and Tasmania be named. News of the circumnavigation made its way back to Europe relatively quickly, and almost immediately a French scientific expedition under Nicholas Baudin was sent to explore the region around Van Diemen's Land (see *Ticket of Leave #2*). Fears raised by this bold move played a large part in the decision to found a second penal settlement on Van Diemen's Land — to claim the island and avoid the possibility of a French settlement there.





he reluctantly agreed. Neither the women nor the islanders objected to this plan, since secretly they knew that the opportunity to travel also meant the opportunity to discover and perhaps establish contact with other Deep One enclaves around the world. The Hybrids brought with them several “good luck charms” which they generously gave to crewmembers, and a more substantial gift — one of Mother Hydra’s sacred fetishes — for Marsh himself.

The four Deep One Hybrids were named:

- *Airoro*, or “*Emma*” — taken to become the “wife” of Gardner, the First Mate. Speaks a bit of English (25%), and some French (20%), in addition to Tahitian. She is the most attractive of the four (APP 75) with elongated eyes and a faint dapple of scale-like skin along her brow and back of the neck.
- *Purahi*, or “*Penny*” — taken to become the “wife” of Clark, the Second Mate. Speaks only French (20%), and a tiny amount of English (10%), in addition to Tahitian. She is fairly attractive (APP 65), with faint webbing between her fingers and toes that is only noticeable in the most intimate of inspections.
- *Taia*, or “*Thérèse*” — taken to become the “wife” of Perkins, the Third Mate. Speaks only pidgin French (25%) and Tahitian. But due to a speech impediment, she is usually quiet, but speaks speaking with a lisp when questions questioned. She is the least attractive of the group (APP 45), somewhat heavysset, with long, thick fingers, and some scales along her spine. However, she is the best swimmer in the group and will likely fully transform in the next 2–3 years.
- *Ura*, or “*Sophie*” — taken to become the “wife” of captain Marsh himself. Speaks pidgin English and French (both at 50%), and Tahitian. The youngest of the group (17 years old) and quite attractive (APP 70), only her sharpened teeth and long nails giving away her Deep One heritage. She is already dead when the adventure begins (see “The Third Mate’s Cabin” on page 19).

## AN ENCOUNTER AT SEA

After departing the Society Islands, Marsh ordered the *Industry* westward. His goal was to capture some whales in the waters surrounding

Australia and New Zealand, which he had heard were particularly rich hunting grounds. Almost as soon as the ship entered the region it makes unprecedented hauls, capturing four whales within the space of three days. The Polynesian women claimed that this is not mere luck, but the “bounty of the seas” that they had brought along with them. The crew were jubilant, picturing the rich purse that each would later receive from such a catch.

On the fourth day of this abundant hunt, the *Industry* landed a prize of a different kind. Exploring an area closer to the eastern shore of Australia the ship caught sight of a British passenger vessel travelling southwards, bound for Port Dalrymple. Approaching this vessel, the *Pride of Poole*, Marsh ordered them to stop or be fired upon. The unarmed ship had little choice but to comply. The crew of the *Industry* boarded the British ship and took as much of its cargo as they could carry. They also took four British passengers from the *Pride of Poole*. The Americans were quick to point out that these were not “captives” but instead passengers who would be completing the remainder of their journey on the whaler instead, with pay going accordingly to the *Industry*’s crew.

## CALAMITY IN THE ANTIPODES

Despite the continued success of the *Industry*’s whale hunt captain Marsh, a god-fearing man, began to suspect the four Polynesian women of being something more than they seemed. The crew considered them a wonderful “good luck charm,” however Marsh vowed that the four — even his own concubine Sophie — should be put off the ship at the next landfall. This was a mistake which would cost Marsh his life.

The Deep One Hybrids were quick to recognize the threat to themselves, and also to develop a plot to subvert the situation. Some of the crew were already on friendly terms with the Polynesian girls, and it was to those men that they insinuated the idea that the ship’s Master was working against their best wishes. The idea of a mutiny soon began to be discussed in secret by a few officers, each of them working on others to win them over to the notion. It was not long before the uprising occurred, led by Gardner and Clark (the First and Second Mates). Though they expected most of the ship to side with them, the mutineers found that they only had support from about half the crew.



## Antipodean Deep Ones vs Lovecraft's Deep Ones

An important plot point in this scenario is the significant difference between the Deep One species as found in Australian waters and the traditional "Lovecraftian" Deep Ones as described in "The Shadow Over Innsmouth" and other stories.

For reasons that are not well understood, the Deep Ones in the Antipodes are a much more primitive and less sophisticated progenitor of the more common species found elsewhere in the world. The two species are related, but neither feels kinship, trust, or loyalty to the other. Both types of Deep Ones worship Dagon and Hydra, however.

In this scenario, the Deep One Hybrids from Polynesia are descended from the Lovecraftian species, while Deep Ones who are native to Bass's Straits or nearby stretches of sea will almost always be the primitive Antipodean variety. This may become important late in the scenario when Investigators might come into the possession of artefacts from the Hybrids which have magical powers to attract Deep Ones. Although these are designed to call traditional Deep Ones, when used in Australia they are very likely to attract Antipodean Deep Ones instead.

The Antipodean Deep Ones are not pleased that these "foreign" Deep Ones are conducting rituals in their waters. While they will never willingly assist Investigators, skilful use of Summon/Contact spells might attract Antipodean Deep Ones to disrupt the Hybrids' ritual at the finale of this scenario (see "A Sacrifice and an Unexpected Party" on page 25).

Havoc ensued. When the initial mutiny did not go as well as expected, two of the Hybrids called for Deep One assistance. Two of the aquatic species answered their call ... but they were not the civilized amphibian creatures the Polynesians were familiar with. Instead they were large, primal, and bestial things — related somehow to the Deep Ones they knew, but also markedly different. These were Antipodean Deep Ones (see the box above), and while the beasts hated and feared mankind they held no particular kinship with the Hybrid women either. The wild creatures attacked indiscriminately, savaging everyone they could get their claws on.

The chaos worked in the favour of the mutineers. The Antipodean Deep Ones killed several of the crew. Marsh's concubine Sophie was killed in the fighting by the Third Mate (who himself perished), and the captain died by his own hand. By the time the fighting had stopped the remaining Hybrids — along with the human survivors — had all abandoned ship and were packed into two of the *Industry's* whaleboats. The boats rowed towards land just visible on the eastern horizon, a pair of small islands in the Furneaux group in Bass's Straits.

### NO REST ON LAND

The first island that the fleeing whaleboats reached was a small landmass named Goose Island on the charts. They found this island to be inhospitable, despite the presence of a (currently disused) sealer's camp. The camp was tiny — just a few huts — and

nowhere near suitable for housing such a large group. The group decided to push on, leaving Goose Island for the second nearby island, Badger Island. This larger island is the site of a more substantial sealer's camp (also currently disused).

After the horrors of the preceding day, the survivors (crew, Hybrids, and passengers) found their first night in the primitive sealer's camp a relief. However, when morning broke Gardner and Clark, the notional leaders of the group, make a terrible discovery: all the whaleboats had been damaged in a night-time storm. The group was faced suddenly with their isolation and forced quickly to figure out what they were going to do.

The group quickly determined that the whaleboats were utterly ruined beyond their ability to repair, given the materials available on Badger Island. To escape the island, they would need to survive long enough for one of the infrequently passing sealing ships to pull into the island camp: realistically this could take months or even years. Their plight was put into even more sharp relief when, during the next day, the pod of Antipodean Deep Ones that had attacked the *Industry* tracked the survivors to the island. The force that attacked was small but extremely vicious, and the Hybrids were able to fend them off with certain ritual war chants used by the common breed of Deep Ones. The Hybrids knew that this was a temporary measure — sooner or later their Antipodean cousins would return with a larger force which they could not repel by sorcery.



## THE ULTIMATE PLAN

In desperation the Polynesian Hybrids hit upon a desperate plan: to escape the island they must attract the attention of one of their unclean “gods,” the huge and terrible being known as Mother Hydra. The ritual to summon their great Mother was well known to the Hybrids, but it required time and human sacrifices. While the former was in short supply, the existence of the captive crew and passengers means the latter requirement is easily satisfied. To enact this unholy ceremony, the group located a secluded cove on Badger Island and on its unspoiled sand erected some stakes to which sacrifices can be bound. Then they began to chant. When the Investigators (most likely) track down the survivors at the conclusion of the scenario, this ceremony will be coming to its climax. If they fail to put a stop to the ritual, Mother Hydra will soon arrive to wreak havoc upon the Furneaux Islands and beyond ...

## A DERELICT AT SEA

In the meantime, while those who fled from the *Industry* cower in fear on their island prison, other ships passing through Bass’s Straits have spotted the abandoned ship floating aimlessly on the sea. One of the vessels was an East Indiaman doing the regular supply run from Sydney to Port Dalrymple. That particular ship arrived in the tiny outpost port with a dramatic tale to tell — not only had they sighted the (possibly derelict) outlines of the *Industry* but they had hailed the vessel with no reply. The Master of the supply ship describes how they even pulled alongside the vessel and, while they could spot no signs of life aboard, they saw enough to conclude that the ship was not only of American origins but also heavily armed.

The military Commandant in charge of Port Dalrymple is alarmed by this news. What mischief could an armed American ship be planning in these waters? Is it somehow tied to the recent declaration of war between Britain and America half a world away? And why had the ship seemingly been left abandoned as a derelict? Could it be part of some elaborate deception?

Clearly there is an imperative to get answers to these questions — something that can only be achieved by sending an expedition to board her.

## Involving the Investigators

The investigators become involved in this scenario by direct means: they are chosen to be members of an expedition party to investigate the mysterious derelict ship. This mission is to be led by an NPC, Ensign Peregrine Plumrose.

The most obvious types of characters to be selected for such a task would be those who are comfortable on or around boats, or at sea, or who have otherwise distinguished themselves as suitable. This could include:

- Experienced mariners who can be called upon to help navigate and guide the rescuers
- Royal Navy sailors and His Majesty’s Marines (who can represent the Colonial government)
- Anyone with a bit of scientific knowledge
- Sealers and whalers who know the area are also extremely welcome to join the expedition

Convicts can be assigned to the expedition either for specific expertise (perhaps gained from working the docks, or working as a carpenter). Alternatively, they can be assigned simply to do the manual labour and grubby tasks which no-one else will do.

If the Investigator group is lacking in skills, the Colonial authorities in Port Dalrymple can assign NPC naval personnel to help fill out the ranks (see the Statistics section at the end of the scenario for some examples).

Unfortunately, fitting female Investigators into this specific scenario is more difficult than most — however that is not to stop a creative Game Moderator from introducing a plausible reason for including such a character. The same is true for Aboriginal Investigators.

## Scenario Overview

The scenario follows a straightforward structure: after being briefed on their mission by the authorities at Port Dalrymple, the Investigators have a short time to ask around town for additional information about sightings of the mystery derelict. Soon, however they will be aboard a ship making its way to the location where the doomed vessel was last spotted. Finding the *Industry* adrift in seas



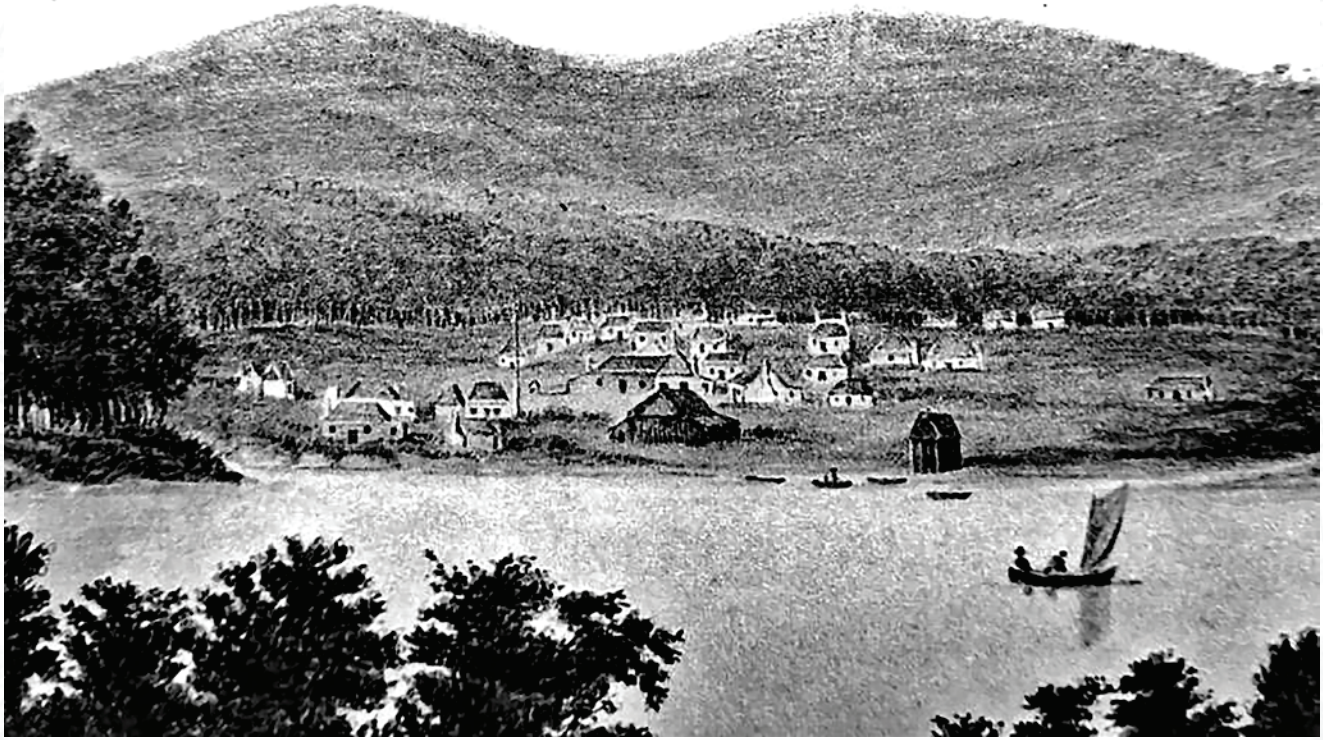

Port Dalrymple in 1808

close to the Furneaux Island group the Investigators can board and search the vessel, likely discovering some clues as to its fate, as well as some of the Deep One artefacts left behind in the rushed evacuation. They will also find many dead bodies and may also discover a cowering survivor.

It should become clear that most of the *Industry's* crew and passengers abandoned ship, which leads to a hunt to track them down. The trail first leads to Goose Island where, despite having only a few traces of the survivors from the derelict will bring the Investigators into contact with a crew of rowdy sealers who arrive to use the ramshackle base on the island (which they built). Eventually the Investigators track the mutineers and Hybrids to Badger Island and a secluded cove half-way along the northern coast where an inhuman ritual is being carried out.

If the ritual goes according to plan, Mother Hydra will rampage through the Bass Strait, perhaps even severely destroying the settlements on Van Diemen's Land as well as culling most of the seal and whale population in the area. But there is something important that the Hybrids have not reckoned upon, namely that pureblood Deep Ones in nearby waters will hear their impassioned calls to Hydra. In these unfamiliar waters, they cannot assume that all who so detect their presence will be allies to

their cause. The culmination of their ceremony will instead herald the arrival of a rampaging horde of Antipodean Deep Ones who will happily slay the sacrifices and the Hybrids. They will gladly kill the Investigators too, if they get the chance.

## Getting Started: A Summons in Port Dalrymple

The scenario begins for each Investigator in roughly the same manner. They are in Port Dalrymple, either as a resident of the remote and threadbare settlement, or as a temporary visitor. Regardless of their station, each is woken by a malodorous and clearly-hungover Navy officer accompanied by four Royal Marines. This is the young Ensign Plumrose, who is notorious around Port Dalrymple for being a plodder who cannot hold his drink.

Ensign Plumrose explains tersely that the reason for his visit at this infernal hour is that the Investigator has been chosen to participate in a mission for the settlement's Commandant. The Ensign himself was awoken at first light by an impolite summons to attend the Commandant's home, whereupon he learned of a matter which will shortly be gossip on every tongue in Port Dalrymple. Last evening, just before sunset an East Indiaman arrived in port with



# Timeline of Events

30 Days Ago: Pitcairn Island	The <i>Industry</i> arrives in the South Seas having left from Valpariso, Chile several weeks earlier. Near to Pitcairn Island, they capture their first whale and begin processing the carcass. Using charts from the American sealing ship <i>Topaz</i> , they briefly visit and trade with the residents of Pitcairn. The crew learns of two British whalers in the area, so their stay is cut short.
21 Days Ago: Leeward islands chain, Society Islands (French Polynesia)	After a brief encounter with an armed British whaler, the <i>Industry</i> looks for a friendly port and decides that the Society Islands are the safest destination. Patrolling British warships around Tahiti and Bora Bora force the <i>Industry</i> to put into a more remote island in the leeward chain. After getting fresh water, food and some supplies, Master Marsh orders the crew ashore for leave while repairs are undertaken.
16 Days Ago: Leeward islands chain, Society Islands (French Polynesia)	Marsh orders the crew back aboard. His Mates Gardner, Clark and Perkins have made "friends" with three local women, and they petition Marsh to allow them to bring the women aboard. Marsh agrees, only if they find another willing woman for his use. The crew comes aboard with trinkets and other gifts from the islanders, including a number connected to Deep One cults.
11 Days Ago: Near Tonga	Marsh and the crew begin to hunt whales, capturing four within the space of three days. The island women claim that this is the "bounty of the sea" coming back to them. Perkins notices that two crewmembers have fallen overboard while on night watch. One of the dead crewmembers was Archie, a Native American sailor from near Kingsport who was suspicious of the Deep One Hybrids and was planning to inform Marsh of his suspicions. A thorough search of the ship does not turn up any sign of them. The rest of the crew have no idea what happened to the missing sailors. All of this is recounted in Marsh's ship log.
8 Days Ago: Western Tasman Sea	The <i>Industry</i> crosses paths with a British passenger ship, the <i>Pride of Poole</i> , forcing her to stop. The American whalers board and claim the ship's cargo as allowed under the letter of marque which they carry. Master Marsh decides that he can make additional money by also compelling four of the wealthier passengers from the <i>Pride of Poole</i> to "complete their journey" on the <i>Industry</i> instead, with a modest additional fee being charged to each such passenger (payable on arrival).
5 Days Ago: Western Tasman Sea, near the Furneaux Islands.	The four Polynesian women, who are Deep One Hybrids, convince two of the <i>Industry's</i> Mates (Gardner and Clark) that the captain wants to put them ashore because he is "afraid of them." Marsh, in fact, believes the four women are somehow involved with the death of the two crewmembers and several other odd occurrences. The Hybrid women encourage some of the crew to mutiny, and in the turmoil they attempt to summon some pure-blood Deep Ones to aid them in the battle. They are shocked when bestial creatures rise up from the waves and attack both sides with primitive fury. The ship plunges into madness and mayhem. The fighting is intense, and the Antipodean Deep Ones are driven off, while the hybrids escape the ship with their allies from the crew ... and several prisoners.
4 Days Ago: Passage through the Furneaux Islands	The party that escaped from the <i>Industry</i> in a pair of whaleboats makes land on one of the Furneaux Islands, a small uninhabited rock named Goose Island on navigational charts. After surveying their surrounds they quickly abandon the island's small (and currently disused) sealer's encampment and head onwards in search of a more comfortable place to hide out.
3 Days Ago: Furneaux Islands	The survivors land on a larger island called Badger Island. This place is home to a larger sealer camp (also currently not being used) which the survivors soon locate. They occupy the camp, figuring to use it as a base until they can figure out what to do next.
2 Days Ago: Bass's Straits	On Badger Island, the survivors find that their whaleboats have been extensively wrecked by an overnight storm. They are also attacked by the Antipodean Deep Ones, who seem to have tracked them down following the previous fight. Ritual chants barely fend the amphibious beasts off. The survivors and the three remaining Hybrids start to search for a way off the island.  In Bass's Straits, the drifting <i>Industry</i> is hailed by an East Indiaman traveling from Sydney to Port Dalrymple. The captain and crew receive no response. They pull alongside and determine the ship is likely a derelict, but also spot that it is both American and heavily armed. The captain reports the encounter to officials in Port Dalrymple on arrival.
Today	Leaving port in a whaling boat, the Investigators arrive nearly 12 hours later at the location of the adrift whaler. Light is fading as the journey took longer than expected due to increasingly bad weather.  On Badger Island, the surviving mutineers and passengers are led by the Hybrids to an isolated cove where they plan to perform a ritual to summon Mother Hydra. Most of the men and women are earmarked as sacrifices.
Day +1	Clues discovered aboard the <i>Industry</i> lead to the Furneaux Islands some distance to the east. Charts show the derelict ship has been drifting for 2–3 days.
Day +2	The Investigators arrive to find remnants of a recent campfire on Goose Island. They also uncover further signs that at least some the crew of the <i>Industry</i> stayed here in an old sealer's camp. Searching the area reveals that none of the <i>Industry's</i> crew are now present. The nearest island they could have gone to is Badger Island a few miles away. While exploring the sealer's camp on Goose Island, the Investigators will unexpectedly encounter a group of sealers pulling in to use the camp.
Day +3 and later	The ceremony to summon up Mother Hydra from the depths of the sea reaches its glorious conclusion. Investigators should confront and stop the ritual, and in the process hopefully rescue the remaining crew and passengers. A complicating factor is that the final phase of the ceremony, designed to call upon a chorus of pureblood Deep Ones to prepare the way for Hydra, instead summons a group of bestial Antipodean Deep Ones. This creates a frantic three-way conflict.



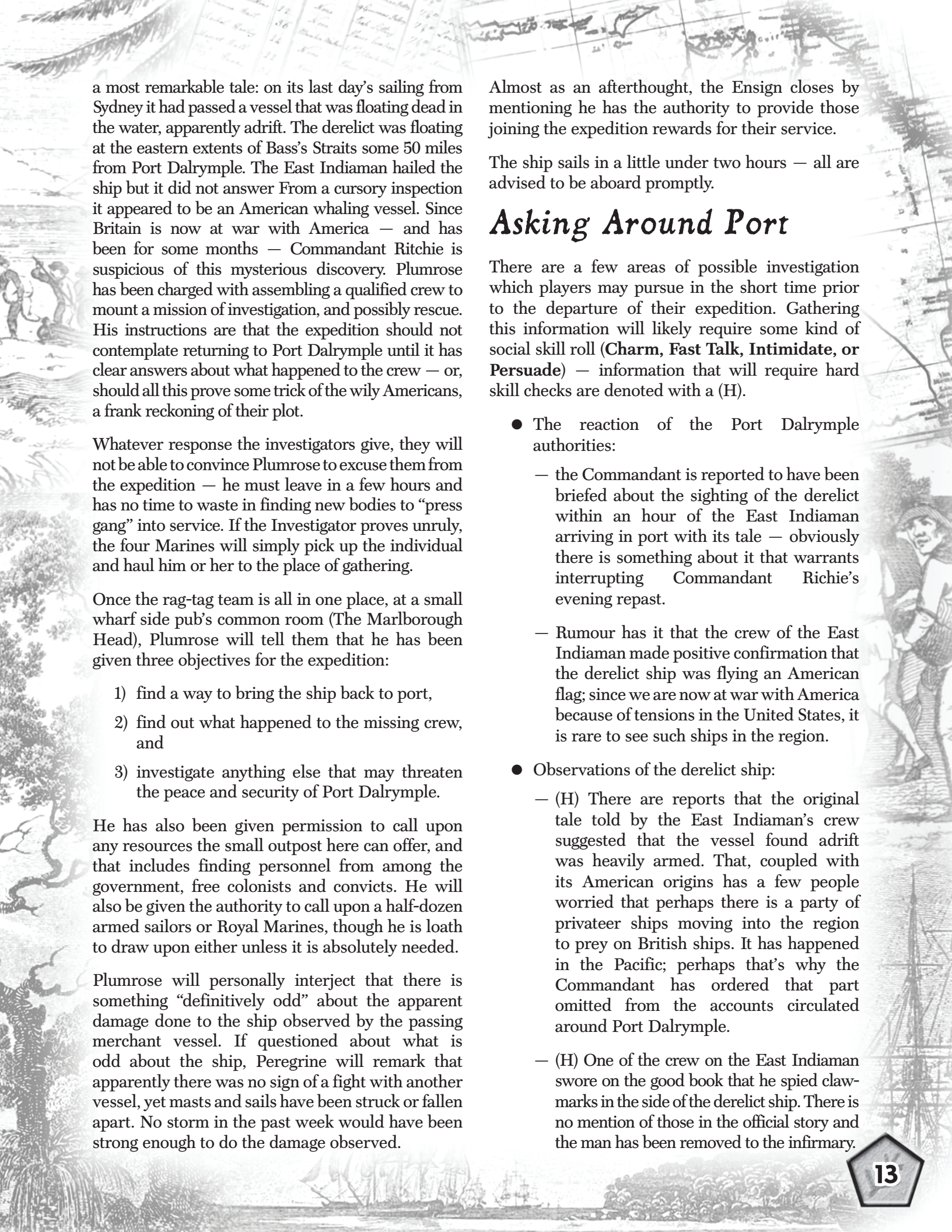

a most remarkable tale: on its last day's sailing from Sydney it had passed a vessel that was floating dead in the water, apparently adrift. The derelict was floating at the eastern extents of Bass's Straits some 50 miles from Port Dalrymple. The East Indiaman hailed the ship but it did not answer. From a cursory inspection it appeared to be an American whaling vessel. Since Britain is now at war with America — and has been for some months — Commandant Ritchie is suspicious of this mysterious discovery. Plumrose has been charged with assembling a qualified crew to mount a mission of investigation, and possibly rescue. His instructions are that the expedition should not contemplate returning to Port Dalrymple until it has clear answers about what happened to the crew — or, should all this prove some trick of the wily Americans, a frank reckoning of their plot.

Whatever response the investigators give, they will not be able to convince Plumrose to excuse them from the expedition — he must leave in a few hours and has no time to waste in finding new bodies to “press gang” into service. If the Investigator proves unruly, the four Marines will simply pick up the individual and haul him or her to the place of gathering.

Once the rag-tag team is all in one place, at a small wharf side pub's common room (The Marlborough Head), Plumrose will tell them that he has been given three objectives for the expedition:

- 1) find a way to bring the ship back to port,
- 2) find out what happened to the missing crew, and
- 3) investigate anything else that may threaten the peace and security of Port Dalrymple.

He has also been given permission to call upon any resources the small outpost here can offer, and that includes finding personnel from among the government, free colonists and convicts. He will also be given the authority to call upon a half-dozen armed sailors or Royal Marines, though he is loath to draw upon either unless it is absolutely needed.

Plumrose will personally interject that there is something “definitively odd” about the apparent damage done to the ship observed by the passing merchant vessel. If questioned about what is odd about the ship, Peregrine will remark that apparently there was no sign of a fight with another vessel, yet masts and sails have been struck or fallen apart. No storm in the past week would have been strong enough to do the damage observed.

Almost as an afterthought, the Ensign closes by mentioning he has the authority to provide those joining the expedition rewards for their service.

The ship sails in a little under two hours — all are advised to be aboard promptly.

## Asking Around Port

There are a few areas of possible investigation which players may pursue in the short time prior to the departure of their expedition. Gathering this information will likely require some kind of social skill roll (**Charm, Fast Talk, Intimidate, or Persuade**) — information that will require hard skill checks are denoted with a (H).

- The reaction of the Port Dalrymple authorities:
  - the Commandant is reported to have been briefed about the sighting of the derelict within an hour of the East Indiaman arriving in port with its tale — obviously there is something about it that warrants interrupting Commandant Ritchie's evening repast.
  - Rumour has it that the crew of the East Indiaman made positive confirmation that the derelict ship was flying an American flag; since we are now at war with America because of tensions in the United States, it is rare to see such ships in the region.
- Observations of the derelict ship:
  - (H) There are reports that the original tale told by the East Indiaman's crew suggested that the vessel found adrift was heavily armed. That, coupled with its American origins has a few people worried that perhaps there is a party of privateer ships moving into the region to prey on British ships. It has happened in the Pacific; perhaps that's why the Commandant has ordered that part omitted from the accounts circulated around Port Dalrymple.
  - (H) One of the crew on the East Indiaman swore on the good book that he spied claw-marks in the side of the derelict ship. There is no mention of those in the official story and the man has been removed to the infirmary.



● Other activity in Bass's Straits:

- It's common knowledge that the waters of Bass's Straits are common hunting ground for whaling and sealing crews. The comings and goings of such vessels have been observed by several ships sailing on government business, but because the whaling and sealing vessels seldom come to port the exact number active in any area is largely unknown.
- The islands in Bass's Straits are all uninhabited ... or at least officially so. The Aboriginal peoples of Van Diemen's Land sometimes row out to them in canoes to hunt the wildlife there, but nobody stays out there.
- (H) There are persistent tales told of ships spotting crews of white men camped on the shores of some of the islands in Bass's Straits. Exactly who these men are and what they are doing on the islands is a mystery.
- A few days ago, a ship called the *Pride of Poole* arrived at Port Dalrymple with reports that they had been raided on their trip from Sydney by an uncouth band of American privateers. The ship lost not only most of its cargo but four of its wealthiest passengers, whose current fate is unknown.

## The Derelict Ship

The expedition sails just after 8 A.M., rowing and sailing through open sea towards the point where the derelict whaler was last sighted. The trip, while tiring for the men on the oars, proves uneventful. After twelve hours, the American whaler comes into view close to the position recorded by the East Indiaman. The sight of the vessel on the horizon invigorates everyone with a new surge of energy that fills limbs and brains. By the time the boat has reached its target, night is fast approaching, and a storm is gathering on the horizon. There is still, however, enough light left to begin investigating the enigmatic vessel.

The seas are a bit rough, with cold water spray soaking all aboard the boats assigned to the party. From 50 yards away, it is obvious the ship is adrift, its main mast broken, hanging over the side, the lines and sails acting as a sea anchor.

## The War of 1812

As noted elsewhere, the time period of this scenario marks a period when Britain was at war with the United States. This conflict is generally known as The War of 1812 and lasted from June 1812 to February 1815. The causes of this conflict are many, including the impressment of American merchant sailors into the British Navy, the blockade of European ports controlled by Napoleon, the encouragement of Native Americans to attack frontier settlements, and dreams of manifest destiny. The war was unpopular in New England, and for the British, the majority of the military forces were fighting Napoleon Bonaparte on the continent.

As far as the colonies in Australia are concerned, the biggest direct impact of the war was a decline in the number of American whaling vessels putting into port at Sydney and elsewhere. British naval forces were stationed in the Pacific to stop U.S. Navy and commerce raiding. British whalers were armed and granted letters of marque to prey on American whalers, and nearly shut down the American whaling industry in the Pacific in the initial years of the war. American merchant vessels were also issued letters of marque, and they captured dozens of ships and hundreds of British merchant sailors.

One of the more infamous encounters was in November 1812, when the *Emu* (a British armed brig converted from a merchant vessel), was stopped on its way to Australia and searched by the American privateer *Holkar*. The *Emu* was seized by the American boarding party without a fight, along with its cargo of 49 female convicts. The female convicts and crew were deposited on the Cape Verde Islands, but were eventually rescued by a passing British ship. The *Emu* itself was towed to the United States. The convicts were returned to Portsmouth, where they waited for months until a new ship could be found to re-transport them to New South Wales.

The remaining mast and sails are hanging loose, flapping in the wind, but still keep the ship slowly moving westward. There is no sign of movement aboard the ship.

As they get within 50 yards of the boat, they bump into a dead sailor floating in the waves. On close investigation it is obvious that the man has had his stomach torn open by claws, his entrails now being eaten by crabs (SAN 0/1). There is more debris including barrels and pieces of crates and boxes floating away from the vessel.



# Handout: Setting Details

## The Penal Colonies in 1812

This adventure takes place in November 1812. The English penal settlements of Australia are now some 24 years old. Whereas the primary purpose of the colonies — to serve as a prison for British and Irish prisoners — has not changed, the steady arrival of free settlers has added a (somewhat unexpected) dimension to the settlement. Similarly, the substantial numbers of convicts who have served out the terms of their transportation but decided to stay in Australia, has added further diversity to the social make-up of the colonies. It is now apparent to most people that the settlements in Australia are not just prisons and not just temporary.

The original settlement at New South Wales is still the principal colony, but a combination of factors has made it desirable to found additional penal settlements further south on the island known as Van Diemen's Land (modern-day Tasmania).

The tenure of William Bligh as Governor of New South Wales (1806—1808) was a turbulent time which inexorably led to an uprising which saw the military gaolers of the colony seize control through armed rebellion. Law and order were restored, however, in 1810 with the arrival of a new official Governor from England, Lachlan Macquarie. Although the chaos of the Rum Rebellion is still fresh in people's minds, the forward-looking actions of Macquarie have done much to establish a more stable and fair society in the colonies. One of the most significant innovations is the notion that "emancipated" convicts (i.e., those who have served out their sentence) should have the same rights as free settlers — this is a notion that has been embraced by some and derided by others. A more recent source of gossip among colonists is the recent declaration of war between Britain and America, a conflict being fought half a world away but still of considerable interest to all British subjects.

## Northern Coast of Van Diemen's Land

There has been interest in the island of Van Diemen's Land for some time, which only intensified after explorer Matthew Flinders circumnavigated the island in 1788—9, proving beyond any doubt that it actually was an island and not joined to the mainland. The stretch of water which separates Van Diemen's Land from the Australian continent was named Bass's Straits, in honour of the ship's surgeon on Flinders' voyage. French interest in the area shortly thereafter led to concerns that the dreaded enemies of Britain

might lay claim to Van Diemen's Land as a colony of their own. In response the Colonial Government in New South Wales sent ships to settle on Van Diemen's land in 1802 and 1803. By the time of this scenario these are well established, and Van Diemen's Land is an independent (albeit small) colony in its own right.

There are two main settled areas on Van Diemen's Land — the region around Hobart Town (on river Derwent at the island's south-east coast) and the area around Port Dalrymple (on the river Tamar at the island's north coast, facing Bass's Straits). This scenario begins in the latter settlement, which is by far the smaller of the two, housing 242 souls (in comparison with Hobart Town with a population around 500). Each settlement is run somewhat independently: the southern settlement is run by Commandant Murray while the Port Dalrymple Settlement is under the command of Captain John Ritchie.

Port Dalrymple at this time serves as a civil and military port. The port is the mouth of the Tamar River and open to Bass's Straits. It is known to receive significant and damaging winds at times. The harbor is said by many to be dangerous in bad weather, because of the rocks and reefs at the mouth of the river. Port Dalrymple is used mostly as a stop-over point for ships sailing between Sydney and Hobart Town, but some goods (including salted meat, flour, rice and iron ore) are unloaded here to be distributed to settlements in northern Van Diemen's Land.

There is a small permanent military detachment at Dalrymple as well as a pilot service that ensures that ships safely enter and leave the harbour. The settlement has an allocation of assigned convicts, although it is not itself a penal settlement — rather the convicts provide much-needed manual labour, and in some cases assist with the operation of the pilot station.

## Bass's Straits

The stretch of water known as Bass's Straits has reputation for being perilous at times, although many ships ply its waters as part of their passage. In addition to passenger and cargo ships travelling between Sydney and Hobart Town, the region is frequently used by whaling and sealing ships.

There are several islands in Bass's Straits, the most notable being King Island at the western end of the strait and a cluster known as the Furneaux Group at the eastern end. All of these islands are uninhabited, home to wildlife but little else. There is some suggestion that sealer crews occasionally set up camps on these islands for temporary use.



# The *INDUSTRY*, An American Whaleship

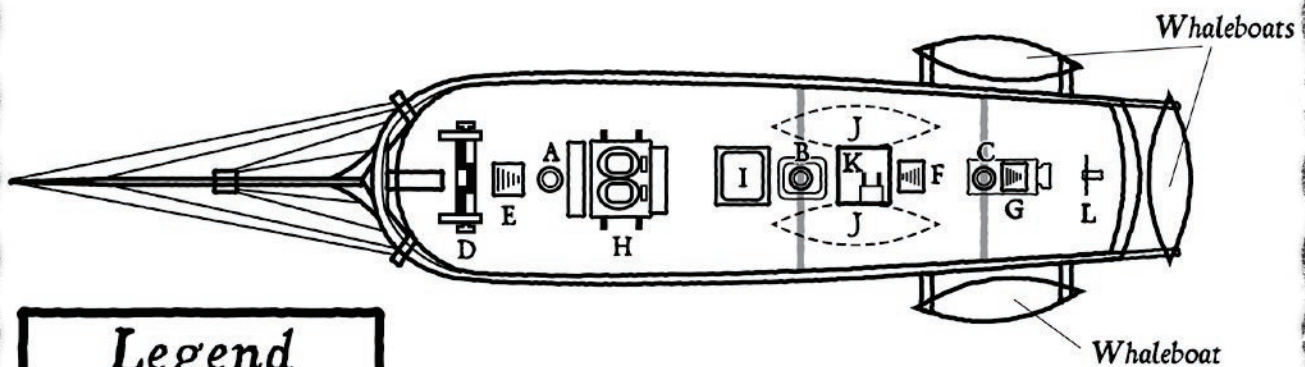

## Legend

- A. Foremast
- B. Mainmast & pumps
- C. Mizzenmast
- D. Windlass
- E. Fo'c'sle Companionway
- F. Midship Companionway
- G. Aft Companionway
- H. Tryworks
- I. Main Hatch
- J. Stowed Whaleboat (in overhead rigging)
- K. Cookhouse
- L. Wheel

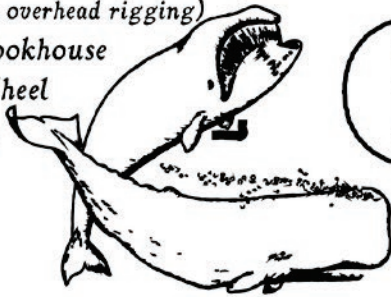
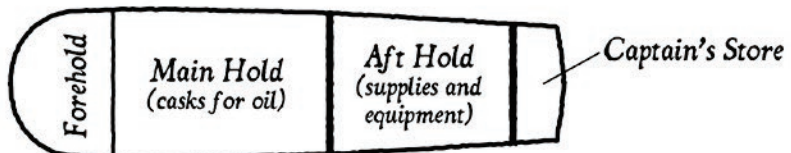
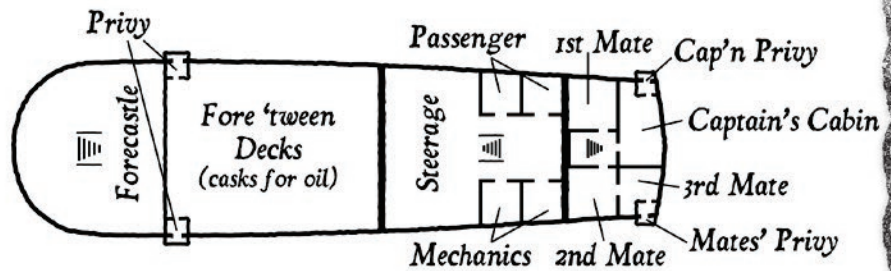

## Boarding the Industry

Upon boarding the ship, two things immediately become apparent. The first is that this vessel is heavily armed, having seven 18-pounder carronades (and signs of an eighth that seems to have plowed through the hull of the ship). The second obvious fact is that there has been some sort of struggle on-board. There are four partially dismembered — and seemingly part devoured — sailors scattered on the deck. Two of the corpses are being eaten by gulls, while another is being gnawed by a pair of large rats. Rain is falling down on the deck and small waves of red water are sloshing back and forth as the ship rocks in the waves.

Investigators who scrutinize the carnage will also easily spot a bloody trail leading away from the site. If followed this leads to a fifth dead sailor, this one hidden under an overturned whaleboat lashed to the deck.

While it is hard to tell what killed the four sailors in the open, the fifth sailor has very obviously had his entrails ripped free by something with large and sharp claws (an Antipodean Deep One). The unfortunate disembowelled man seems to have survived the attack for a time and managed to write a short bloody inscription on the inside of the whaleboat. It reads: "Beware what comes from the sea."



## EXPLORING THE DERELICT

The general layout of the *Industry* is described in “Deck Plan” on page 16. The Game Moderator can use this as a general guide to the typical items that will be found in each area. Notes on specific areas of the ravaged derelict are described below.

### The Ship’s Whaleboats

Even a cursory exploration of the deck of the *Industry* will reveal that two of her whaleboats are missing. If examined, the one boat left on davits at the rear of the ship contains the bloody remains of one of the crew.

One of two spare boats has also been pulled from its stowage in overhead rigging and lies overturned on the deck. This is the boat mentioned above, with the bloody trail leading to it and the dead man underneath.

### The Cookhouse (Kitchen)

Investigators exploring the cookhouse will find another dead body, in similar condition to those found outside on the main deck.

Aside from this gruesome discovery there is nothing particularly remarkable about the derelict’s kitchen. Investigators who have a nautical background can (with an INT roll) notice that there is a surprising lack of pests in the kitchen. Apart from a few rats, the place — and the rest of the ship for that matter — seems free of them. Although there is no way the Investigator would know, but this is a side effect of the presence of the Hybrids and Antipodean Deep Ones: normal fauna shuns proximity to their unnatural influence.

## AFT SECTION BELOWDECKS

At the aft of the *Industry* there is a companionway (ladder) leading downwards to the area where the ship’s Master and Mates have their personal cabins.

### The Master’s Cabin

This cabin was used by used by Ebenezer Marsh and still contains has navigation equipment. This is arranged on his desk, along with charts of New South Wales, Tasmania, New Zealand, and the South Seas. It is relatively easy (with an INT or **Navigate** check) to trace the ship’s voyage from Chile to the Furneaux Islands through annotations on the map.

Aside from the neatly-arranged desk, everything else in the cabin is in a state of disarray as if someone had hastily rifled through the room.

The cabin contains two sea chests. One holds Marsh’s clothing, personal belongings, the ship’s log, a sextant and other navigation tools. The other sea chest is mostly empty, but there are some Islander and European women’s attire within, as well as a small traditional Polynesian tattooing kit in an ornately-carved wooden box.

A detailed account of recent weeks aboard the *Industry* can be pieced together from the ship’s log. Information to be found in the log includes:

- An outline of the events described in the timeline on page 12.
- A list of the crew and passengers: 26 sailors (2 African Americans, 4 Native Americans, 18 Americans, and 2 British sailors), plus the four officers. Two of the 26 crew are listed as missing, presumed dead: Archie, a Native American sailor from Kingsport, and Thomas Flynn, a British sailor originally from Bristol. The front page of the log records that the *Industry* is home ported in Kingsport, Massachusetts, but the majority of the American crew are from Nantucket and Marblehead.
- The names of the *Industry*’s officers: Master Ebenezer Marsh of Kingsport, First Mate Amaziah Gardner of Nantucket, Second Mate Jethro Clark of Marblehead, and Third Mate Edmund Perkins of Kingsport.
- A note indicating the presence of 4 passengers, who “chose to come aboard” when the *Industry* encountered the British vessel *Pride of Poole* a little over a week ago. Marsh’s notes suggest he plans, if possible, to deliver them to Sydney or at least drop them ashore where they can make their way to civilization.
- Earlier entries in the log also describe the circumstances of the *Industry*’s visit to the Society Islands, and especially the impassioned demands by his officers to bring aboard native female concubines “with exotic and occasionally odd looks.” He speaks of the crew trading food and supplies for gold and jewellery, and that many of the crew traded personal items for protective charms and items from the islanders.





One of the final entries in the ship's log is disconcerting (SAN loss 0/1D3). Marsh speaks of hearing voices in the night, and feels drawn to the sea, as if voices from the water surrounding the ship are calling to him. He also mentions that his concubine, Sophie, had often been missing from his bed at night, and when he confronted her, she said she need to get some air. He had increasingly come to believe she was plotting with her "sisters" and that they were subverting his officers and crew. While a **Psychology** check might reveal that Marsh was sane, the writing certainly gives the impression that he is losing his mind. The last line ends "I am going to confront Gardner and Clark in the morning, for they are the ones who seem to be at the centre of the recent disturbances. They will answer me, or I will put them off with those horrid women."

If Investigators thoroughly explore the Master's cabin they may (with a **Spot Hidden** roll) notice a small door hidden behind other debris and equipment. This leads to a private privy at the rear of the ship. The privy is basically a small space built along the rear curve of the ship, consisting of a wooden toilet over the open water. Inside the small space, if the door is forced open or taken off its hinges, is the body of Master Marsh. There is a flintlock pistol in one hand, his brains partly blown out and covering the wall of the privy.

### The First Mate's Cabin

This cabin belonged to Gardner, the First Mate, and shows obvious signs of having been packed up hastily. It also shows definite signs of a feminine presence in the cabin.

Gardner's sea chest is still present and can be searched by Investigators. At the bottom can be found the *Mother Hydra's Fetish* (see the box nearby) wrapped up in some of Gardner's shirts and undergarments. The chest also contains some scribbled notes made by Gardner that indicate that he has been dreaming about the ocean "and the allure of the sea."

Atop Gardner's compact desk are a small clay pipe with a black tarry residue in it, several burnt tapers, and a small sealed waxed paper pouch containing a small black tarry ball. (These are signs that cabin's occupants have been consuming opium by smoking it, as any **Medicine** roll will determine.)

## Mother Hydra's Fetish

This four-inch carved statuette depicts a foul fish-human hybrid, carved in an unidentifiable green soapy stone. The fetish is unpleasant to the touch, seeming to subtly squirm in the holder's grasp (despite never visibly moving). If an individual holds the statuette for longer than five minutes, its innate unnatural force will attempt to infiltrate his or her mind. The holder must make a series of **opposed POW** rolls against the statuette's POW of 75; the first failure causes a vision of a vast green undersea realm, teeming with attractive members of the opposite sex; the second failure compels the holder of the statuette to travel to the nearest coastal region.

If the fetish successfully causes its bearer to reach the sea, one final **opposed POW** roll is allowed — success by the afflicted individual allows him or her a moment of clarity where the enormity of the horror of Mother Hydra is a sufficient shock to break the connection (causing a loss of 2/2D6 Sanity Points but allowing the holder to drop the fetish). If this final roll fails, however, the bearer of the fetish is compelled to walk into the briny depths loudly chanting an invocation entreating Mother Hydra to rise from the waves (and involuntarily sacrificing 3 Magic Points). Whether the great Mother chooses to heed the call is left as a question for the Game Moderator to decide.

If Mother Hydra is successfully summoned via the fetish, use the statistics provided on page 286–7 of *Call of Cthulhu, 7th Edition*.

(Reprinted from *Convicts & Cthulhu: Ticket of Leave #4*, page 11).

### The Second Mate's Cabin

As with First Mate's cabin, the compartment allocated to Second Mate Clark looks as though somebody has rapidly collected items hastily as if to flee the ship.

Clark's sea chest contains two pouches of American tobacco, two clay pipes, and a small snuffbox filled with six small gold finger rings. The rings are of a strange design, hammered from raw gold, and they have a slight cold and damp feel to them. If an Investigator chooses to wear one or more of the rings, he or she will feel a strange sensation of connection with an alien mind (SAN 0/1). This is the Investigator's consciousness making contact with one of the Antipodean Deep Ones that is still circling in the waters close to the *Industry*,



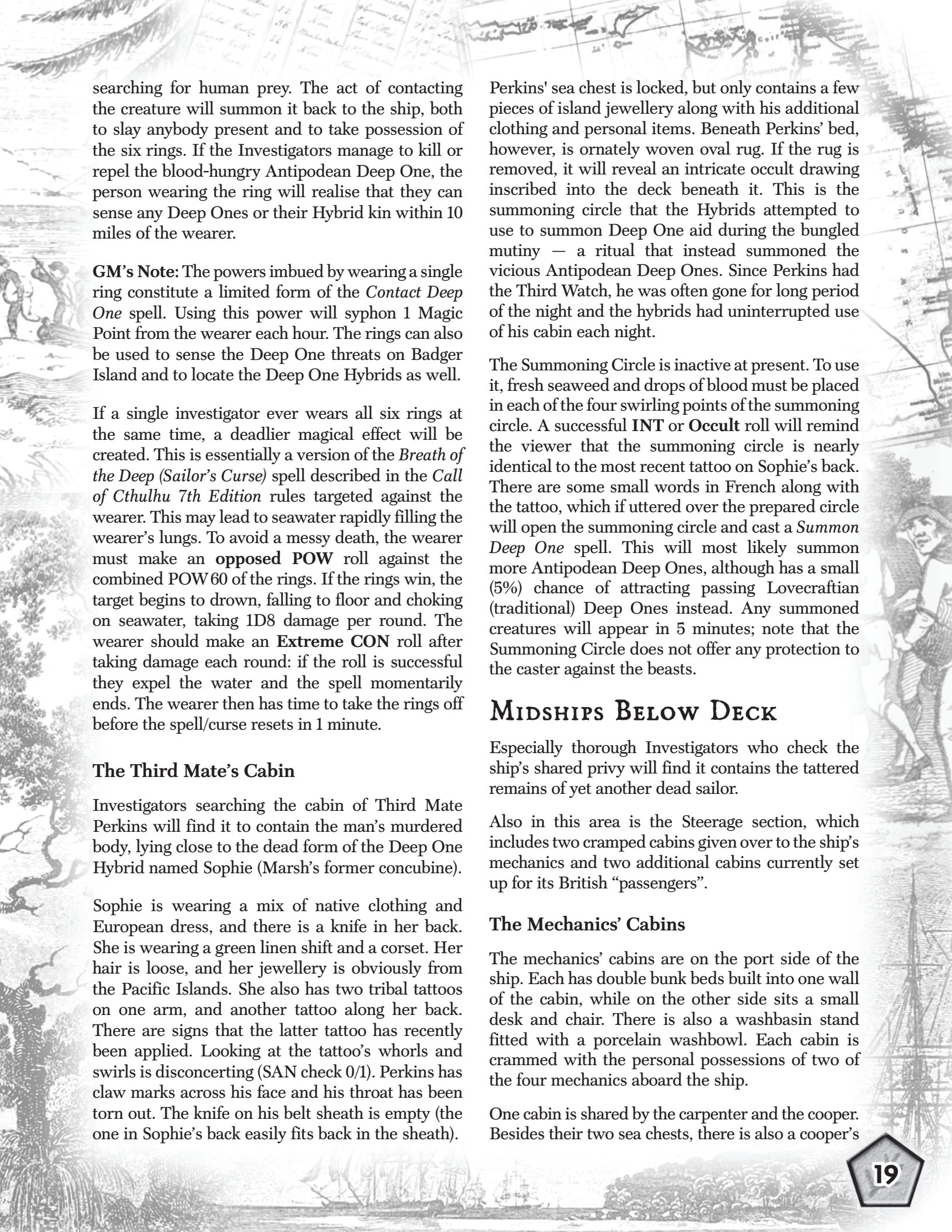

searching for human prey. The act of contacting the creature will summon it back to the ship, both to slay anybody present and to take possession of the six rings. If the Investigators manage to kill or repel the blood-hungry Antipodean Deep One, the person wearing the ring will realise that they can sense any Deep Ones or their Hybrid kin within 10 miles of the wearer.

**GM's Note:** The powers imbued by wearing a single ring constitute a limited form of the *Contact Deep One* spell. Using this power will syphon 1 Magic Point from the wearer each hour. The rings can also be used to sense the Deep One threats on Badger Island and to locate the Deep One Hybrids as well.

If a single investigator ever wears all six rings at the same time, a deadlier magical effect will be created. This is essentially a version of the *Breath of the Deep (Sailor's Curse)* spell described in the *Call of Cthulhu 7th Edition* rules targeted against the wearer. This may lead to seawater rapidly filling the wearer's lungs. To avoid a messy death, the wearer must make an **opposed POW** roll against the combined POW60 of the rings. If the rings win, the target begins to drown, falling to floor and choking on seawater, taking 1D8 damage per round. The wearer should make an **Extreme CON** roll after taking damage each round: if the roll is successful they expel the water and the spell momentarily ends. The wearer then has time to take the rings off before the spell/curse resets in 1 minute.

### The Third Mate's Cabin

Investigators searching the cabin of Third Mate Perkins will find it to contain the man's murdered body, lying close to the dead form of the Deep One Hybrid named Sophie (Marsh's former concubine).

Sophie is wearing a mix of native clothing and European dress, and there is a knife in her back. She is wearing a green linen shift and a corset. Her hair is loose, and her jewellery is obviously from the Pacific Islands. She also has two tribal tattoos on one arm, and another tattoo along her back. There are signs that the latter tattoo has recently been applied. Looking at the tattoo's whorls and swirls is disconcerting (SAN check 0/1). Perkins has claw marks across his face and his throat has been torn out. The knife on his belt sheath is empty (the one in Sophie's back easily fits back in the sheath).

Perkins' sea chest is locked, but only contains a few pieces of island jewellery along with his additional clothing and personal items. Beneath Perkins' bed, however, is ornately woven oval rug. If the rug is removed, it will reveal an intricate occult drawing inscribed into the deck beneath it. This is the summoning circle that the Hybrids attempted to use to summon Deep One aid during the bungled mutiny — a ritual that instead summoned the vicious Antipodean Deep Ones. Since Perkins had the Third Watch, he was often gone for long period of the night and the hybrids had uninterrupted use of his cabin each night.

The Summoning Circle is inactive at present. To use it, fresh seaweed and drops of blood must be placed in each of the four swirling points of the summoning circle. A successful **INT** or **Occult** roll will remind the viewer that the summoning circle is nearly identical to the most recent tattoo on Sophie's back. There are some small words in French along with the tattoo, which if uttered over the prepared circle will open the summoning circle and cast a *Summon Deep One* spell. This will most likely summon more Antipodean Deep Ones, although has a small (5%) chance of attracting passing Lovecraftian (traditional) Deep Ones instead. Any summoned creatures will appear in 5 minutes; note that the Summoning Circle does not offer any protection to the caster against the beasts.

## MIDSHIPS BELOW DECK

Especially thorough Investigators who check the ship's shared privy will find it contains the tattered remains of yet another dead sailor.

Also in this area is the Steerage section, which includes two cramped cabins given over to the ship's mechanics and two additional cabins currently set up for its British "passengers".

### The Mechanics' Cabins

The mechanics' cabins are on the port side of the ship. Each has double bunk beds built into one wall of the cabin, while on the other side sits a small desk and chair. There is also a washbasin stand fitted with a porcelain washbowl. Each cabin is crammed with the personal possessions of two of the four mechanics aboard the ship.

One cabin is shared by the carpenter and the cooper. Besides their two sea chests, there is also a cooper's





tool box full of tools. The carpenter's tools are missing. (**Game Moderator note:** The cooper is the body discovered under the overturned whaleboat on the deck. The carpenter left with the mutineers).

The second cabin was shared by the cook and the surgeon's mate. Besides their two sea chests, there is the surgeon's mate's box of medical supplies and a satchel with some basic surgery tools. There is also a box, rifled through, that has some dried spices and herbs, as well as a small box of sweet biscuits in waxed paper, and two small waxed pouches of dried dates. (**Game Moderator note:** Both men escaped with the mutineers).

## The Passenger Cabins

On the starboard side of the ship, directly opposite from the mechanics' cabins are a pair of cabins decked out as cramped yet serviceable sleeping quarters for passengers. Each cabin holds bunks for two persons. Both cabins are currently empty, but both were obviously occupied recently.

One of the cabins contains several feminine touches, and for the past week or so has been home to the two female passengers taken from the *Pride of Poole* — Miss Davinia Brookes and Miss Mavis Poole. Sea chests belonging to each of the ladies may be found in the cabins; searching through either reveals that the two passengers were young women from England. The contents include sundry personal belongings, mostly clothing. Miss Brookes' chest reveals that she was reading a book by Jane Austen, *Sense and Sensibility*.

The second cabin was used recently as the quarters for the two male passengers taken from the *Pride of Poole* — Lieutenant Trevor Jewett and Reverend Cedric Brookes. The sea chests for both Jewett and the Reverend are still in the cabin.

- Jewett's chest holds some changes of clothing and personal items. Beneath his folded clothes is a silver locket with a painting of a pretty young woman within. Jewett also carried a small handwritten note from Miss Davinia Brookes asking Jewett to keep an eye on her brother, the Reverend.
- Reverend Brookes' chest contains a few sparse personal belongings. A small bible has some scribbled markings on the end papers, basically a brief journal talking about the medicines he was given by the Polynesian girl Penny, while aboard the *Industry*. The notes also include an account of discussions the Reverend had with Penny about religion and life on the islands. There is no hint in his writings of anything improper happening between the two, merely that Brookes was fond of the strange young woman and concerned for her immortal soul. There is a small amulet of native island manufacture in the bottom of his sea chest.

## THE HOLD

The ship's hold can most easily be accessed by opening the main hatch on the deck.

While filled with barrels of oil and whalebone, there are also two Antipodean Deep Ones who were trapped below decks during the mutiny. Anyone who opens the main hold cover will be assailed by the smell of oil and fish and will soon be attacked by the two trapped Antipodean Deep Ones. See the statistics at the end of the adventure.

## THE FO'C'SLE (FORE SECTION BELOWDECKS)

The Forecastle can be reached by descending the forecastle companionway from the main deck. This area is where half of the crew lived (12), their bunks small, narrow, with only a thin straw filled mattress to provide comfort. There are a dozen or so sea chests of varying sizes scattered around this space, each containing the personal belongings of one of the crewmen. About half of them have been opened, their contents hastily rifled through, while the other half remain closed, some locked, some not. Other than personal belongings, there are some small primitive trinkets and items bartered for from the local natives along





their journey. At least one or two of the men were evidently excellent scrimshaw carvers.

Investigators thoroughly searching the bunks in this section may discover that under one of the mattresses of a top bunk is a series of hastily drawn occult symbols. A successful **Occult** roll will indicate that they are protective wards against possession and the evil eye; if the roll is a **Hard** success, it can be determined that these marks have been drawn by someone with only a limited knowledge of the Occult.

## The Survivor

There is a more significant discovery to be made in the Fo'c'sle. Towards the front of area — in the narrowest section of the ship — an impromptu barrier has been constructed through the arrangement of five sea chests. If the Investigators make a cursory inspection of the area they will only notice this detail with a successful **Spot Hidden** roll. However, if they methodically go through every one of the trunks, they will certainly notice it by the end of their 15-minute search.

If the Investigators remove the barrier they will discover the frightened form of a woman in her early 20s huddling behind the sea trunks, wearing a dress partially torn. She is holding a wooden canteen and a handful of hardtack biscuits which are crumbled and gnawed upon. Her hair is a mess, dishevelled and wild, and her eyes show little rational thought. She will scream when exposed but can be calmed with the use of **Psychology** or another reasonable skill.

The woman in question is Miss Mavis Poole, one of the passengers who “chose” to join the *Industry* when it raided the British vessel *Pride of Poole*. Once she is calmed down she can provide an account of her week-long ordeal (see page 27).

If asked for additional information about the other passengers taken from the *Pride of Poole*, Mavis knows the following:

- Miss Davinia Brookes is 19 years old, and the sister of Reverend Cedric Brookes who was also taken. The minister was headed to Port Dalrymple where he was to take up a new parish.
- Lieutenant Trevor Jewett is a young (25-year-old) officer in the 73rd Regiment of Foot based in Van Diemen's Land. He has spent

some time in the new colonies, but most recently was obliged to return to England due to illness. He was returning to his regiment, despite still bearing a badly broken arm. He tried to put up resistance against the raiders, but his impairment made it a futile gesture.

- Reverend Cedric Brookes, brother of Davinia, is a young Anglican minister dispatched by the church to assume parish duties in a place called Port Dalrymple. Throughout the whole of the voyage from England, the Reverend has suffered most severely from seasickness. Ironically this malady abated once aboard the *Industry* thanks to tribal medicine supplied by the exotic island girls.

## Who Died, Who Survived?

At the time of the mutiny and the attack of the Antipodean Deep Ones, there were 36 people aboard the *Industry*, made up of:

- 4 officers (Marsh and the three Mates)
- 24 crew
- 4 Deep One Hybrids
- 4 British passengers taken from the *Pride of Poole*

Of the officers, two died aboard the ship — captain Marsh and the Third Mate Perkins. The bodies of these two may be found in their respective cabins. That leaves two officers unaccounted for: Gardner and Clark.

Four crew can be found decomposed and floating in the water, while three more are dead on the open deck. The cooper's body can be found under the overturned whaleboat on the main deck (as described above). Another of the crew can be found dead in the bottom of the remaining whaleboat still hanging from davits. That leaves fifteen crew unaccounted for, including the ship's carpenter and surgeon's mate.

Of the four Polynesian women (Deep One Hybrids), only one is to be found dead aboard the *Industry*; the other three are unaccounted for.

The British passengers are all missing except for Miss Mavis Poole.

In all that means there are some 23 persons whose whereabouts are still unknown.



# Mavis' Story

*My name is Mavis Poole, and I am headed for Hobart Town where my cousin Major Henry Eastlake awaits me. He is a soldier in the 73rd Regiment of Foot. I sailed from England some five months ago aboard a British ship called the Pride of Poole. The passage was unpleasant for everyone, a combination of terrible seas, outbreaks of disease, and cramped quarters making the journey taxing. All that was, however, nothing compared to what transpired a week ago when the Pride of Poole was making its last leg from Sydney to Hobart Town. While out in open waters a vessel approached our ship, seeming to come from nowhere. She flew an American flag and our crew said it was fiercely armed. That ship was the one we are currently sat upon. Out of fear of a broadside from the American cannons, the Pride of Poole's Master dropped sail and allowed the rough and uncouth men to board.*

*The Americans were of the lowest class and smelled terrible. They were evidently whalers and bore the disgusting odour of that trade. The Master of the whaler told the British sailors that he carried a "letter of marque" from the United States, allowing for the legal seizure of all cargo from the Pride of Poole. Many people objected, of course, but the force of arms aboard the Poole was not great and was hopelessly outnumbered by the disgusting Americans.*

*Once the whalers had finished pilfering whatever they wished from the hold of our ship, they came back for one last trip. This time, they said, they wanted passengers. The crude way that they put it was that theirs was a superior vessel and that four "lucky" passengers were to be given the chance to complete their journey on the fast whaling ship, with additional payment for that service owed at the return to an Antipodean port. Although their words were masked in guile it was plain that those chosen by the unclean privateers — myself, the Reverend Brookes and his sister, and the injured Lieutenant Jewett — truthfully had no say in the matter.*

*We joined this whaling ship, which I believe is called the Industry, over a week ago and were given cramped but clean quarters in Steerage. The officers of the vessel, although brutish to the extreme, did not treat us unkindly as all of us had feared. The rougher men who crewed the ship seemed to go out of their way to avoid us. We quickly learned that we were not the only "passengers" on the Industry — at some earlier South Seas port, the officers had acquired for themselves "wives" from among the island people. There were four young island girls, one for the Master and one for each of the Mates. The arrangement was most unclean and ungodly, and the Reverend told the officers of the Industry in no uncertain terms that by resorting to their baser natures they were damning themselves to Hell. If only he knew how soon that damnation might arrive.*

*After his initial outbursts the Reverend took to speaking at length with one of the South Seas girls and came to understand that despite not yet having accepted the Christian God, they were in their own way victims of the foul Americans. One of the islander girls even helped the Reverend cure his perennial*

*sea sickness, providing him with a folk remedy of their peoples. From speaking with his frequent visitor Reverend learned that the presence of the islander girls aboard the Industry had created a schism among the crew and that to settle it the Master of the ship, a crude man called Marsh, had resolved to cast the women off the ship at the next island they passed. This plan, once widely known among the crew, only served to boil the rebellious American blood ... and before any action could be taken to calm matters, fully half the crew were in mutiny.*

*The fighting among the American sailors was fierce, as one would expect. Barricading ourselves in the passenger cabins kept us safe from most of the battle although not from the terrible sounds of conflict throughout the ship. At some point in the mutiny, other combatants joined the fray and the sounds of fighting were replaced by blood-curdling screams of terror from the mouths of stolid seafaring men. Here I must beg some indulgence from you, for I doubt that you shall believe the remainder of my tale though I saw it with my very own eyes.*

*Our safehold in the passenger cabins was soon breached by frantic American sailors. According to them, horrors from the sea had boarded the Industry and had taken it upon themselves to slay every soul, mutineer or loyalist. These sailors and many others had decided that the only chance to preserve their lives was by abandoning the Industry in one of the ship's whaleboats. All four of us "passengers" were taken by these men up onto the deck. I was at the back of the group being protected by the ship's cook while the others were transferred to one of the boats. Without warning, I heard a bestial howl — the like of which nothing on God's green earth could make — and an enormous form, part-man, part-fish launched itself upon the cook. Two of the other crew pulled me away from the horror, though I still caught sight of the razor-sharp claws of that terrible amphibian devil slicing through the stomach of the cook and his innards spilling to the deck.*

*The two sailors who had drawn me away from the conflict showed me down here, to the place where the lower orders of crew bunk down. Here they left me with a cask of water and some food, telling me to barricade myself against the ship's hull and pray that the devils did not find me. After making the hiding place for myself, where you yourselves discovered me, I fell into a faint. When I awoke I was most afeared. It was dark, and no sounds of life came from anywhere on the ship. Neither the demonic fishmen nor any American sailors could I hear. I have spent days in this self-confinement, too frightened to venture forth lest the horrors from the sea assail me with their rapacious claws. My only forays from the place of safety have been brief escapes to use a "honey bucket" in the main hold.*

*I ask of you kind and godly folk just one thing — help this beleaguered soul make it back to civilization, as soon as can be arranged. I plead that you do this as an act of mercy for someone who has experienced more than any young girl should ever need to endure.*



The background of the page features a detailed illustration. At the top, there is a map showing a coastline with various points of interest. Below the map, the scene transitions to a ship's deck, where several figures are visible, some appearing to be working or observing. The overall style is that of a historical or nautical-themed illustration.

# Tracking the Survivors

Once the expedition has explored the *Industry*, it should have been learned that a substantial number of persons from that vessel (crew and passengers) remain unaccounted for — most likely having abandoned ship. While some Investigators may argue the mystery of the derelict as solved, Ensign Plumrose will disagree. According to his orders nobody can return to Port Dalrymple without having tracked down the crew of the derelict. Furthermore, information unearthed during the search of the ship points to a clear possibility of a hazard or danger to shipping in the region: this, too, needs to be investigated. Naturally, the Ensign will in no way believe wild tales of “fish devils” but some great force of nature must have been involved in the death and destruction witnessed aboard the derelict.

Consulting the navigation charts brought by Plumrose, Investigators will quickly note that there are a group of small islands quite close to the position where the *Industry* was discovered. Assuming the men who fled the ship were experienced maritime men — which they seem to have been — there is no question that they would have made for the nearest land, even if only as a temporary stopover before heading onwards in the missing whaleboats. Clearly the best chance of tracking down the survivors from the derelict is to search those islands.

## On Goose Island

The landmass closest to the *Industry*'s current position is a small (270 acre) uninhabited island called Goose Island. This is very likely where the mutineers would have gone. This place is little more than an elongated granite island, which the Investigators can reach with less than an hour's rowing from the derelict.

The first thing that will become apparent to the Investigators as they approach Goose Island is that it is currently uninhabited — although there is a small sealer's camp clearly visible on one of the beaches. This small station on consists of two huts made of sailcloth and whalebones, and three broken sets of whale bone supports for two more buildings. The camp contains lots of bones of dead seals (overall, sealers killed about 25,000/year!), as well as other debris that shows that sealers still occasionally visit from time to time.

There does not appear to be any sign of anyone currently using the camp. If Investigators make landfall and undertake a thorough search of the camp, however, there are very clear signs that someone has been here in the past two days, including a recent campfire. This was, in fact, where the mutineers briefly stopped. After just an hour on Goose Island, Gardner (who has assumed leadership of the group) realised that this tiny camp was not big enough to adequately house everyone. It was also too rundown and damaged by storms. He ordered his rag-tag bunch back into the whaleboats to row to the much larger island which could now be seen as lying just two miles further east.

Investigators may spend an hour or more sifting through the remains of recent campfires and the debris left behind by the mutineers. At the end of their search they learn nothing more than the group set a fire here but did not use the buildings for accommodation.

## AN UNEXPECTED INTERRUPTION

As the expedition prepares to leave Goose Island, the Investigators are startled to see a jolly boat pulling up to the beach. This is a party of sealers — the same group who built this camp originally. This four-man team are opportunists who travel from sealing camp to sealing camp raiding supplies and occasionally hunting seals to harvest skins and meat. The camp on Goose Island is their ‘home base’ and they will naturally be suspicious of anyone who is poking around.

Depending on how the Investigators deal with these new arrivals, they can be allies or potential enemies. The four are independent operators and will be wary of any government officials. Two of the four are escaped convicts from around Hobart Town, while the other two are American sealers whose ship left them behind as it attempted to flee a winter storm several months ago.

If the Investigators infuriate the sealers or attack them, use the statistics at the end of the scenario to resolve the conflict.

On the other hand, if they somehow convince the sealers they pose no threat (and have no intention of reporting their presence to the colonial authorities), the rough sealers will be friendly. The statistics at the end of the scenario also provide backgrounds for these NPCs. The sealers will show the Investigators how they have concealed, beneath one of the camp's



crude huts, a stockpile of seal hides and Aboriginal items they have collected. The former are bound for sale in Port Dalrymple, but they will happily sell them to the Investigators for a fair price. The same is true of the Aboriginal artefacts.

The most helpful consequence of befriending the renegade sealers, though, is the ability to question them about recent activity in the region. When quizzing the group, any success with a social skill (**Charm, Fast Talk, Intimidate, or Persuade**) will learn that just yesterday the team tried to pull in at the larger sealer camp on neighbouring Badger Island only to be rebuffed by a large group of strangers. The renegades spotted two large whale boats and signs of cook fires as well as several men. If the Investigators describe the collection of survivors from the *Industry*, the sealers will nod and confirm the group they saw was greatly similar.

Depending on the relationship between the expedition and the sealers, Snow (their *de facto* leader), may volunteer to join the expedition on condition that his group can take whatever they can plunder from the camp on Badger Island. If the expedition has been depleted by earlier encounters, Ensign Plumrose may even ask the sealers to join the team; in this case the negotiations will hinge upon whether the government man can make assurances that the sealers can get what they want back on Van Diemen's Land.

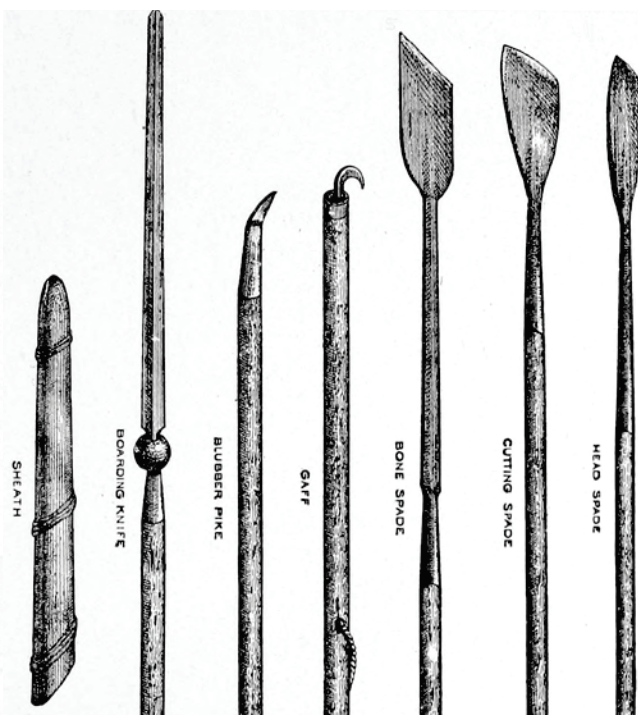

## On Badger Island

The expedition should eventually find their way to Badger Island, which is where the party of mutineers is currently encamped (having commenced a multi-day ritual to summon Mother Hydra). The group might decide to visit this place because it is the next-closest island to the site of the mutiny, or they may have heard the first-hand account of the renegade sealers that suggests a large party has recently arrived there.

Badger Island is much larger than Goose Island, incorporating some 3,100 acres of land. It is well-wooded and visited on a seasonal basis by Aboriginal groups for hunting. It hosts an extensive population of Tasmanian pademelons (smaller than wallabies) and wallabies (smaller than kangaroos), along with seabirds and reptiles. Seals can still be found here in large numbers, along with mutton birds.

The sealer's camp on the north-western coast of Badger Island is much larger than that on Goose Island, and currently unused by sealers. By the time that the Investigators arrive there, it has also been abandoned by the mutineers — who were viciously attacked here by Antipodean Deep Ones. The survivors of that attack have relocated to a secluded cove some 2 miles to the north-east.

## THE SEALER'S CAMP ON BADGER ISLAND

The sealer's camp consists of four 10 ft. by 20 ft. structures used as housing for the sealers. Each is made of sailcloth, with whalebone and wooden supports. Each has a driftwood floor atop the sand. There are also two try pots, brick fire pits, and several drying racks for skins and hides. Two large, rusting try pots are left on their side. There is also a smaller 10 ft. by 10 ft. wooden structure that is currently empty but was used for stores.

On the beach adjacent to the camp can be seen the broken remains of two large whaleboats. Both have been extensively holed and damaged, intentionally so. They are obviously no longer seaworthy. Off to the right side of the camp, above the high tide line, are two large dirty sails stretched over items piled on the ground.

Inside the four huts are most of the personal belongings of the crew and passengers from the *Industry*. This includes bed rolls, some spare clothes, satchels with personal belongings, and the occasional knife or belaying pin. There are signs that everything was hastily abandoned.





## GREEN BOTTLES

A **Spot Hidden** roll will notice that there are a number of empty green glass bottles scattered about. Inspecting any of these bottles will show that a small amount of liquid remains within, something smelling of alcohol but also something astringent. Tasting the liquid will numb the tongue. Anyone sampling the brew must make a **CON** check or suffer unpleasant effects: the liquid will send the imbibor into a fit of animalistic frenzy, making them easily irritated by anyone and everyone around them. If anyone tries to forcibly stop the frenzied individual, he or she will strike back at those trying to stop or restrain them. The frenzy lasts for 1D6+1 minutes, after which the affected person will pass out for an hour. Upon awakening, he or she will have no idea what they may or may not have done.

**GM's Note:** During the attack by the Antipodean Deep Ones, the remaining Hybrids tried to employ a semi-magical brew which instils a berserker-like frenzy. They gave this concoction to several of the mutineer sailors to engineer an orgy of violence at the sealer's camp as a distraction, allowing everyone else to escape.

## A MAKESHIFT MASS GRAVE

Five of the *Industry's* sailors are found dead beneath one of the large dirty sails, as well as a man dressed in a white shirt and breeches, with a broken arm in a sling (Lieutenant Jewett). Each has been slashed, throats cut by razor-like blades, or heads smashed in by rocks or clubs/belaying pins. There are also signs that some web-footed creatures were also present on the beach.

## A NARROW TRACK

Investigators searching the area around the sealer's camp may (with a **Spot Hidden** roll) detect a narrow track leaving the clearing and cutting through the dense bushland. This appears to have been made by a group of barefoot people moving through the grass and dirt towards the north-east. If followed, this trail of broken foliage and disturbed terrain will lead to the campsite at the cove (see below).

## A Sacrifice and an Unexpected Party

There are a few ways in which the expedition may find their way to the present location of the mutineer party and its Hybrid-led ceremony. The most obvious method is by following the trail from the sealer's camp — this leads about 2 miles through scrubby grass and light wood before descending into a secluded cove with a wide sandy beach. The Investigators may also locate this hidden site if they undertake a circumnavigation of Badger Island in their whaling boat, or if they scour the island in search parties (although both of these methods will require skill rolls, either **Navigate** or **Spot Hidden**). Reaching the cove by sea will require some significant exertion by rowers, since they will be pushing against some strong currents. Finally, if the ritual being run by the Deep One Hybrids is nearing its completion it may be creating some spectacular meteorological phenomena — perhaps localized thunder or huge black clouds — which are centred directly above the concealed cove.

No matter how the Investigators reach the beach-side spot, the same remarkable sight will greet them upon their arrival. The remaining ship's five surviving crew members and two remaining passengers (Reverend Brookes and his sister) are all tied upright to thick stakes driven into the sandy soil. Nearby, close to the steep escarpment at the back of the cove there stand two small and decrepit huts made of sealskin and whalebone. In the center of the semi-circle made by the restrained crew is an unburied stone altar.

Two of the Deep One Hybrids — Penny and Thérèse — are standing among the restrained crew and passengers, painting the bare torsos of the humans with thick inky paint. The whorls and sigils are disconcerting (SAN loss 0/1) and represent components of the final stage of the ritual. The third of the Hybrids — Emma — is with First Mate Gardner and Second Mate Clark in the hut to the left facing the water, where she is in the middle of a final orgy with the two brainwashed and insane sailors. These two men have almost outlived their usefulness: the ceremony calls for them to become the first to be sacrificed atop the altar.

Investigators who look out towards the water of the cove (or have arrived on boats still floating in the shallows) will likely spot several dark shapes lurking just below the water.





## Things Move Towards Their End

The Investigators will arrive at the cove at a crucial time, when the ritual to summon Mother Hydra is reaching its ultimate climax. As they watch on (or rush towards the beach) they first see Penny and Thérèse emerge from the hut trailing behind them the naked Gardner and Clark. The bodies of both men are covered with parallel scratch marks. As the Hybrid pair pass by one of the sailors tied to a stake they casually slay the crewman by plunging a strangely carved dagger deep into his heart. Gardner and Clark sway and drool slightly as they watch the sacrifice, perhaps sensing that they are to be next.

If left unmolested, the Hybrids gather at the altar and summon the two ships Mates to join them; they silently follow the command, kneeling next to the unclean stone. One by one the Hybrids will slit the throats of these men, allowing their lifeblood to flow out across the altar.

One of the Hybrids will then stand behind the stone and cry out in a loud voice “Now let the children

of Hydra rise from the waves to take their victims, to be consumed in the sight of the Great Mother who shall join us for the feast!” This is the point in the ritual where Deep Ones are supposed to rise from out of the waters to disembowel and devour the sacrifices. This will occur — but the Deep Ones that emerge from the waves and begin marching onto the beach are not those akin to the Hybrids, but rather the bestial forms of 10+2D10 Antipodean Deep Ones. These wild creatures howl in defiance at the Hybrids’ call to their own sacred mother. They beasts are hell bent on killing everyone they can get their razor-sharp claws upon, but especially the Hybrids, who they see as abominations.

At this point, the Hybrids will realise that things have gone awry, and that the only chance of a successfully finishing the ritual is to rapidly dispatch the sacrifices and give the final inhuman cry that serves as the verbal component of the ritual call to Hydra. Accordingly, they will become imbued with a bitter frenzy. If left unchecked, the Antipodean Deep Ones will likely take five minutes or more to make their way from the waters of the cove to the surf and thence to the ceremonial site. If the



Hybrids can kill the remaining six tied-up sacrifices and cast their bodies onto the altar (so their blood stains its surface) before they are interrupted, their summons will doubtless succeed.

One of the Hybrid women, Emma, will begin the Deep One war chant which fended off the small group of Antipodeans which earlier attacked the nearby sealer camp. Against a large group, however, this will do little more than delay their progress (giving 10 minutes rather than 5 to complete the slaying of sacrifices). The other two Hybrids will race between the captives in an impassioned killing spree. To accelerate the process, the Hybrids will first untie Reverend Brookes — who is a convert to their cause (see nearby box) — and instruct him to first slay his own sister Davinia (“so the two of you can be together for eternity”) then turn the knife on himself.

If the Investigators stand by and spectate, the Game Moderator should assume that the Hybrids working in parallel with one another can achieve the necessary murders in the time required. If that is allowed to happen, the chant of the Hybrids will rise into a fever pitch, and the sky will suddenly echo with a booming sound as the previously-calm waters of the cove roil and roll. In a few short moments, Mother Hydra will arise from the depths to answer the summons of her (Lovecraftian) children and simultaneously revel in the bestial power of her more primitive (Antipodean) children. She will gleefully watch on as carnage erupts across the beach — Hydra loves all of her children equally, playing no favourites. Regardless of how the situation plays out, she will begin her own primal reign of terror whose effects will be felt far and wide.

## Halting the Ritual

It is unlikely that Investigators will allow the ritual to reach its terrible conclusion without at least putting up a fight. There are several different ways in which things could play out:

- If the Investigators delay the Hybrids for long enough that the Antipodean Deep Ones arrive, the pitched battle between the two species will begin before the ceremony has completed. This will be accelerated if the Investigators can halt Emma’s Deep One war chant (since stopping it will allow the Antipodeans to storm the beach even faster). If forced into a battle, the Hybrids will still

## The Passion of Reverend Brookes

Although he will be found tied up like the rest of the prisoners at the cove, Reverend Brookes has somewhat fallen under the spell of the Hybrids and is more than likely to cast his lot with them if given the choice. The fall of the Reverend began shortly after the mutiny when Penny, the Hybrid he had formed a bond of friendship with aboard the *Industry*, began to work on him. Making use of natural charms and magical enhancements she was able to overcome the will of Brookes, turning him into ally. Now, the Reverend is a broken man believing he is in love with his “fiancée,” Penny, whom he wants to marry and take to Hobart.

When found by the Investigators, Brookes will pretend to help any rescuers, while waiting for the right moment to turn on them. Any threat to Penny will send Brookes into a frenzy to protect his “true love.”

desperately try to open the arteries of the remaining victims, but they will be hideously outnumbered and are likely to fall before achieving this goal.

- If the Investigators are able to kill all of the Hybrids before they make their invocation “let the children of Hydra rise” then they will effectively prevent the Antipodean Deep Ones from coming ashore. Earlier phases of the ceremony completed by the Hybrids have brought them to this place but if the invocation is never given then the bestial creatures will not remain in the area for long, especially if they can sense that the much-hated Hybrids are all dead.
- If the Investigators use the rings and/or knowledge of the summoning circles, either of which they could have obtained on the *Industry*, they have their own way of bringing the Antipodean Deep Ones forth from the waters regardless of anything else that is happening with the ritual. This could be a useful strategy if the Hybrids are delayed by actions on the beach and do not give their invocation to the waiting Deep Ones, but present a foe which the Investigators cannot themselves easily vanquish.



- Finally, if the Investigators have somehow gotten the *Industry* working again they can sail it to the cove and use its powerful cannons to lob cannonballs at both the Hybrids and the Antipodean Deep Ones (and even Mother Hydra, should she appear).

In the event that the Investigators have had it too easy during the final confrontation, e.g., by sitting back in safety and watching the two Deep One factions destroy one another, the Game Moderator can always throw a wrench into the situation. There is always the chance that once the Hybrids are all dead, the Antipodean Deep Ones decide that it is in their interests to complete the ceremony under their own steam. After all, Mother Hydra is their goddess too, and they would be only too pleased to see her summoned under their own terms and by their own chants.

## Rewards and Penalties

If the Investigators are successful in stopping the ritual, defeating the Deep One Hybrids, and bringing any surviving crew and passengers back to Port Dalrymple, government officials will richly reward them. Survivors should be rewarded with +2D6 Sanity Points. In addition, success should bring a boost to Credit Rating of +1D6 percentiles, and an additional +2D6 percentiles if they manage to bring the *Industry* back to port with its cargo relatively intact.

If they bring back any of the Deep One Hybrids, they will be rewarded by the Commandant with +1D6 percentiles to their Credit Rating. However, he will seize the logs, maps and any journals the Investigators have gathered together and pledge them to silence about the presence of “sea devils”, especially the hybrid creatures. Any convict will either have their sentence reduced by 1D3 years, or will receive a Conditional Pardon, but they will also be threatened with harsher work assignments if they do not remain silent about what they saw.

On the other hand, if the Investigators fail to stop the ritual, Mother Hydra will rampage through the Furneaux Islands, destroying any presence of human existence, and will even submerge some of the islands. She will also call up a tidal wave 75 feet high to sweep along the northern coast of Van Diemen’s Land. Port Dalrymple will be destroyed

utterly. The destruction will be horrific, and any surviving Investigators will lose a further 1D10 Sanity knowing that they were responsible for the damage and suffering. Mother Hydra will return the ocean depths 48 hours after she is summoned ...

## Statistics

Game statistics for *Call of Cthulhu 7th Edition* are shown below.

### *Ensign Peregrine Plumrose*

ROYAL NAVY OFFICER, AGED 28.

Plumrose is from a middle-class English family and went to sea at the age of 12. As a young man Midshipman, caught up with the fleet mutiny at the Nore in 1797, he has had a black mark on his record ever since. Hoping to finally get ahead, he agreed to join one of the naval vessels heading to Australia in 1805, having been promoted to Ensign after serving during Trafalgar. Once he arrived in New South Wales, he was soon sent to Port Dalrymple to oversee the naval trade going in and out of the port. Having helped with salvage of the wreck of the Hebe in 1808, caught on the reefs near Low Head, he has some experience dealing with derelict ships. Plumrose is competent enough, but not the most inspiring leader of men.

The Ensign has been assigned four Royal Navy sailors to help row the two long boats assigned to his command. The four NPC sailors should each have basic sailing skills and be armed with a knife of sorts as well as a cutlass.

---

STR 60 CON 50 SIZ 65 DEX 50 INT 80  
 APP 65 POW 60 EDU 55 SAN 60 Hit Points: 11  
 Damage Bonus: +1D4 Build:1 Move: 7 Magic Points: 12

---

Brawl 35% (17/7), damage 1D3 + Damage Bonus  
 Cutlass 50% (25/10), damage 1D8 + Damage Bonus  
 Carbine 55% (27/11), damage 1D10+4 [base range 70 yards, 1 shot per 4 rounds, malf 95]  
 Dodge 55% (27/11)

Skills: Credit Rating 65%, Insight 55%, Intimidate 45%, Listen 45%, Natural World 50%, Science: Botany 35%, Stealth 40%, Spot Hidden 55%.



## Additional Sailors for the Expedition

If the expedition needs some additional members to fill out its numbers, any or all of the following NPCs can be selected by Plumrose to join the party.

### DESMOND DAVITT

ROYAL NAVY SURGEON'S MATE, AGED 24.

STR 55 CON 50 SIZ 65 DEX 75 INT 75  
 APP 55 POW 65 EDU 80 SAN 65 Hit Points: 11  
 Damage Bonus: none Build:0 Move: 8 Magic Points: 13

Brawl 50% (25/10), damage 1D3 + Damage Bonus  
 Knife 50% (25/10), damage 1D4 + Damage Bonus  
 Cutlass 45% (22/9), damage 1D8 + Damage Bonus  
 Dodge 40% (20/8)

Skills: Boating 50%, First Aid 60%, Swim 25%.

Possessions: Shirt, Sailor Slops, Stockings, Shoes, Jacket, Healer's Case.

### IVOR INGRAM

ROYAL NAVY ABLE SEAMAN, AGED 19.

STR 60 CON 50 SIZ 65 DEX 55 INT 40  
 APP 40 POW 45 EDU 35 SAN 45 Hit Points: 11  
 Damage Bonus: +1D4 Build:1 Move: 7 Magic Points: 9

Brawl 50% (25/10), damage 1D3 + Damage Bonus  
 Knife 50% (25/10), damage 1D4 + Damage Bonus  
 Cutlass 45% (22/9), damage 1D8 + Damage Bonus  
 Dodge 45% (22/9)

Skills: Artillery: Cannon 35%, Boating 50%, Swim 25%.

Possessions: Shirt, Sailor Slops, Stockings, Shoes, Jacket.

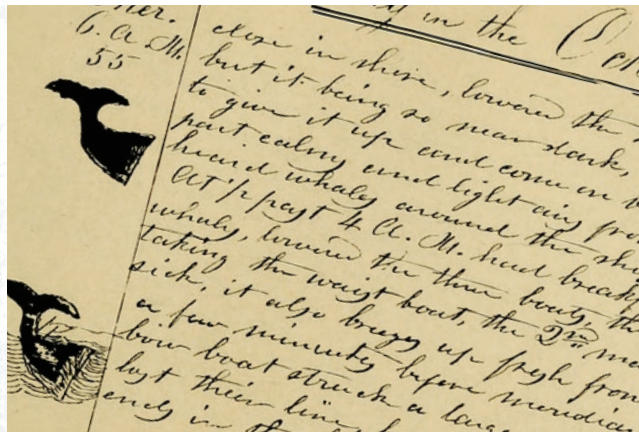

### NEVILLE NORTON

ROYAL NAVY BOS'UN, AGED 30.

STR 80 CON 55 SIZ 75 DEX 45 INT 50  
 APP 70 POW 55 EDU 45 SAN 55 Hit Points: 13  
 Damage Bonus: +1D4 Build:1 Move: 8 Magic Points: 11

Brawl 50% (25/10), damage 1D3 + Damage Bonus  
 Knife 50% (25/10), damage 1D4 + Damage Bonus  
 Cutlass 45% (22/9), damage 1D8 + Damage Bonus

Flintlock (x2) 45% (22/9), damage 1D6+1 [base range 10 yards, 1 shot per 4 rounds, malf 95]

Dodge 35% (17/7)

Skills: Boating 60%, Natural World 35%, Swim 25%.

Possessions: Shirt, Sailor Slops, Stockings, Shoes, Jacket.

### SIMON SHARPE

ROYAL NAVY CARPENTER'S MATE, AGED 20.

STR 75 CON 40 SIZ 70 DEX 60 INT 55  
 APP 55 POW 60 EDU 55 SAN 60 Hit Points: 11  
 Damage Bonus: +1D4 Build:1 Move: 8 Magic Points: 12

Brawl 50% (25/10), damage 1D3 + Damage Bonus  
 Knife 50% (25/10), damage 1D4 + Damage Bonus  
 Cutlass 45% (22/9), damage 1D8 + Damage Bonus  
 Dodge 40% (20/8)

Skills: Boating 50%, Carpentry 55%, Mechanical Repair 65%, Swim 25%.

Possessions: Shirt, Sailor Slops, Stockings, Shoes, Jacket, Carpenter's Box (Basic tool box).

## The Sealing Gang

This four-man band of cut-throat sealers/raiders which may be encountered at their camp on Goose Island.

### FERGAL NOWLAN, ESCAPED CONVICT

Nowlan was sent to Australia as punishment for acts of rebellion in Ireland. Six months ago he was being transported from Sydney to Hobart when he managed to escape from a work party, along with Alastair Biggs (below). He will scowl at any authority figures and remain relatively quiet, letting the others speak first. He just wants to have his freedom back, even a Ticket of Leave, to do what he wants: start a farm.



---

STR 75 CON 45 SIZ 75 DEX 60 INT 55  
APP 35 POW 60 EDU 25 SAN 45 Hit Points: 12  
Damage Bonus: +1D4 Build:1 Move: 8 Magic Points: 12

---

Brawl 40% (20/8), damage 1D3 + Damage Bonus  
Knife 40% (20/8), damage 1D4 + Damage Bonus  
Axe 40% (20/8), damage 1D8+1 + Damage Bonus  
Dodge 65% (32/13)

## ALASTAIR BIGGS, ESCAPED CONVICT

Biggs was transported after having been convicted as a thief. He has not been a model prisoner and has had his sentence extended by the colonial authorities. He escaped from a work party six months ago along with Fergal Nowlan. He wants to go back home to England, believing he has served his time, but will settle for a pardon.

---

STR 60 CON 65 SIZ 75 DEX 80 INT 65  
APP 50 POW 75 EDU 45 SAN 60 Hit Points: 14  
Damage Bonus: +1D4 Build:1 Move: 8 Magic Points: 15

---

Brawl 50% (25/10), damage 1D3 + Damage Bonus  
Wood Staff 25% (12/5), damage 1D8 + Damage Bonus  
Small Knife 50% (25/10), damage 1D3+1 + Damage Bonus  
Dodge 60% (30/12)

## RICHARD SNOW, RENEGADE AMERICAN SEALER

Snow has spent years in these waters, bouncing around Bass's Straits and to Sydney and back. He believes he is the leader of the group. However, the eruption of the War of 1812 means he is caught in an awkward situation. If he learns Americans are involved in the Investigators' mission, he will be willing to join the expedition, hoping they can return him to Martha's Vineyard. Snow is the most practical of the group and will treat honestly with the group, and if they promise to find a way to get him back to the United States, he will fight to the very end.

---

STR 60 CON 70 SIZ 90 DEX 65 INT 55  
APP 55 POW 80 EDU 50 SAN 65 Hit Points: 16  
Damage Bonus: +1D4 Build:1 Move: 7 Magic Points: 16

---

Brawl 50% (25/12), damage 1D3 + Damage Bonus  
Harpoon 65% (32/13), damage 1D8+1 + Damage Bonus  
Flintlock (x1)\* 35% (17/7), damage 1D6+1 [base range 10 yards,  
1 shot per 4 rounds, Malf 95]  
Dodge 40% (20/8)

\* Snow carries only enough powder for two shots.

## WINSTON YATES, AFRICAN-AMERICAN SAILOR & SEALER

Yates hails from Nantucket in Massachusetts. He was aboard a vessel that foundered in Bass's Straits about a year ago. Since that time, he has been associating with Richard Snow, and more recently with Nowlan and Biggs. He is probably the most competent among the four, but also the most mercenary. Yates likes Van Diemen's Land, but he also knows he will probably go with Snow if no other option is presented.

---

STR 60 CON 65 SIZ 65 DEX 50 INT 70  
APP 60 POW 65 EDU 60 SAN 50 Hit Points: 13  
Damage Bonus: +1D4 Build:1 Move: 7 Magic Points: 13

---

Brawl 55% (27/11), damage 1D3 + Damage Bonus  
Pocket Knife 55% (27/11), damage 1D3 + Damage Bonus  
Impr. Spear\* 55% (27/11), damage 1D6+1 + Damage Bonus  
Dodge 40% (20/8)

\* Yates' spear is an impromptu lash-up made with a broad-bladed knife strapped to a wooden staff. It is liable to break if placed under any pressure.

## Prisoners on the Industry

Of the four British subjects obliged to transfer to the *Industry*, three may be encountered alive during the scenario.

## REVEREND CEDRIC BROOKES, ANGLICAN MINISTER, AGED 28.

---

STR 60 CON 75 SIZ 65 DEX 50 INT 70  
APP 55 POW 70 EDU 75 SAN 15 Hit Points: 14  
Damage Bonus: +1D4 Build:1 Move: 7 Magic Points: 14

---

Brawl 50% (25/10), damage 1D3 + Damage Bonus  
Knife\* 50% (25/10), damage 1D4+1 + Damage Bonus  
Dodge 30% (15/6)

\*The Reverend usually keeps his knife concealed beneath the torn coat that was provided by his beloved Penny for his "protection."

Skills: History 25%, Insight 60%, Natural World 35%, Persuade 65%, Language: Latin 55%, Religion 65%, Stealth 45%, Swim 25%.



## MISS DAVINIA BROOKES, AGED 19.

STR 35 CON 80 SIZ 60 DEX 80 INT 85  
 APP 75 POW 40 EDU 75 SAN 30 Hit Points: 14  
 Damage Bonus: none Build:0 Move: 8 Magic Points: 8

Brawl 25% (15/5), damage 1D3 + Damage Bonus  
 Dodge 60% (30/12)

## MISS MAVIS POOLE, AGED 22.

STR 40 CON 50 SIZ 45 DEX 70 INT 65  
 APP 80 POW 75 EDU 80 SAN 52 Hit Points: 9  
 Damage Bonus: none Build:0 Move: 8 Magic Points: 15

Brawl 25% (15/5), damage 1D3 + Damage Bonus  
 Dodge 40% (20/8)

## The Polynesian Hybrids

BEAUTIFUL-YET-DOOMED LADIES OF THE SEA, AGED ??

	STR	CON	SIZ	DEX	INT	POW	APP	HP	MP
Emma	80	80	60	90	50	65	75	14	13
Penny	75	80	50	80	75	50	65	13	10
Thérèse	70	90	65	80	50	70	45	15	14

Damage Bonus: +1D4 Build: 1

Move: 8/8 Swimming

Spells: Brew Frenzy Juice, Contact Mother Hydra, Chant to Ward Off Rival Deep Ones

**Hold Breath:** Deep One Hybrids cannot breathe underwater until they complete change, but they can hold their breath twice as long as the average human.

### ATTACKS

Attacks per round: 1

**Fighting Attacks:** A Deep One Hybrid can use weapons as humans do.

Fighting 45% (22/9), damage by weapon type/brawl  
 Dodge 30% (15/6)

Armour: None

Skills: Jump 45%, Listen 50%, Stealth 46%, Swim 60%

Sanity Loss: 0/1D4 Sanity points to see a Deep One Hybrid.



## Antipodean Deep Ones

Ten examples of Antipodean Deep Ones are shown below. The Game Moderator should reuse these statistics as needed for the small army that assaults the cove.

	STR	CON	SIZ	DEX	INT	POW	HP	MP	Build	DB
One	80	65	90	80	55	45	15	09	2	+1D6
Two	100	75	70	75	55	50	14	10	2	+1D6
Three	100	45	85	80	45	30	13	06	2	+1D6
Four	110	65	90	70	60	60	15	12	2	+1D6
Five	100	50	75	75	50	35	12	07	2	+1D6
Six	60	45	75	70	50	35	12	07	1	+1D4
Seven	105	55	75	60	50	45	13	09	2	+1D6
Eight	110	75	70	55	45	40	14	08	2	+1D6
Nine	70	80	80	70	60	35	16	07	1	+1D4
Ten	100	55	60	65	55	45	11	09	1	+1D4

Move: 9/12 Swimming

Spells: None

**Amphibian:** Dwelling under the sea, Deep Ones can breathe underwater without assistance and are capable of breathing on land.

### ATTACKS

Attacks per round: 1

Claws 45% (22/9), damage 1D6 + Damage Bonus  
 Dodge 30% (15/6)

Armour: 1-point skin.

Sanity Loss: 0/1D6 Sanity points to see an Antipodean Deep One.



# Bibliography

There are several other places where a Game Moderator can find further historical information about whaling and Van Diemen's Land. A few selected sources are provided below.

## Books

Eric Jay Dolin, *Leviathan: The History of Whaling in America*, WW Norton & Company, 2008.

Nathaniel Philbrick, Thomas Nickerson, Owen Chase, et al., *The Loss of the Ship Essex, Sunk by a Whale: First Person Accounts*, Penguin Classics, 2000.

*These are the first-person accounts of the loss of the whaler Essex in the South Pacific and the source material for Melville's Moby Dick.*

## ONLINE RESOURCES

Whaling Vessels & Terminology: <https://www.whalingmuseum.org/learn/research-topics/overview-of-north-american-whaling/vessels-and-terminology>

"Life aboard a Whaling Ship," <https://www.whalingmuseum.org/learn/research-topics/overview-of-north-american-whaling/life-aboard>

"Sealing," The Companion to Tasmanian History, [http://www.utas.edu.au/library/companion\\_to\\_tasmanian\\_history/S/Sealing.htm](http://www.utas.edu.au/library/companion_to_tasmanian_history/S/Sealing.htm)

"Whaling," The Companion to Tasmanian History, [http://www.utas.edu.au/library/companion\\_to\\_tasmanian\\_history/W/Whaling.htm](http://www.utas.edu.au/library/companion_to_tasmanian_history/W/Whaling.htm)

Townrow, K., "Sealing Sites on Macquarie Island: An Archaeological Survey", *Papers and Proceedings of the Royal Society of Tasmania*, Volume 122 (1), 1988, retrieved from: [https://eprints.utas.edu.au/13861/2/1988\\_Townrow\\_Sealing\\_sites.pdf](https://eprints.utas.edu.au/13861/2/1988_Townrow_Sealing_sites.pdf)

---

Like what you've read, but don't yet own the core Convicts & Cthulhu sourcebook? [Head over to RPGNow or DrivethruRPG and grab yourself a copy](#), either in PDF or softcover Print-On-Demand. Either can be obtained under a "Pay-What-You-Want" pricing model where you pay only the basic cost of creating the copy (\$0 for PDF, or about USD \$4 for the softcover book) plus whatever extra you'd like to send the way of Cthulhu Reborn as a "thank you" donation.