

THE CAIRO GUIDEBOOK

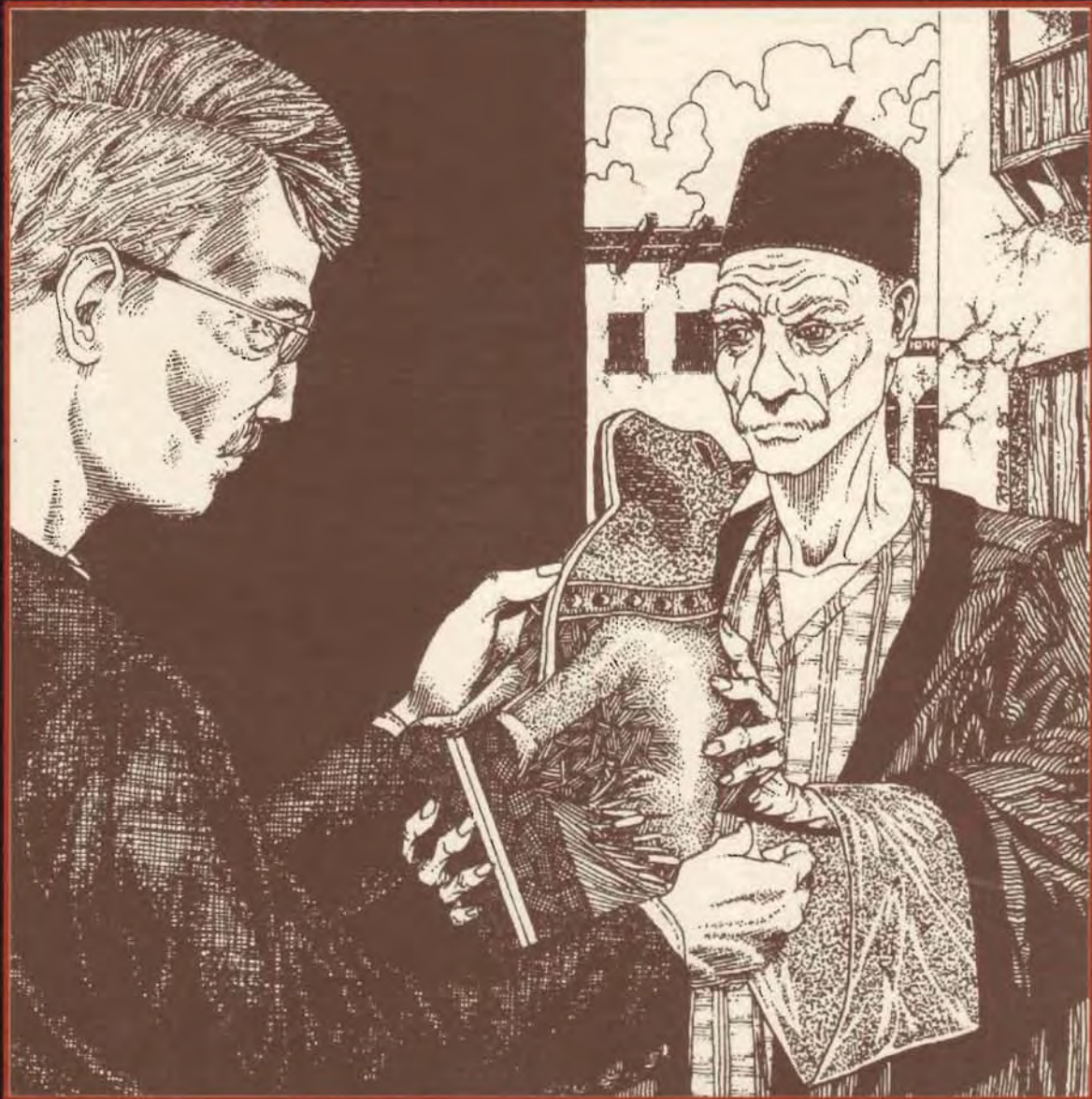

Marion Anderson

WITH PHIL ANDERSON & MARK RYBERG



The Cairo Guidebook

The Lure of the Nile





H. P. LOVECRAFT 1890-1937

The Cairo Guidebook

The Lure of the Nile

by
Marion Anderson

interior illustrations **MARK RYBERG**
maps **PHIL ANDERSON**

project leader and editorial **LYNN WILLIS**
editor and layout **JANICE SELLERS**
Egyptology consultant **CHRISTOPHER HANRAHAN**
proofreading **ANNE Φ. MERRITT**
cover design and layout **CHARLIE KRANK** and **ERIC VOGT**



Chaosium Inc.
1995

Contents

Forewordv	Excursions from Cairo58
	Giza 58
Going to Cairo1	Up the Nile 61
Getting There from Here 1	Tel el-Amarna 63
Alexandria 4	Luxor and Environs 66
Port Said and the Nile Delta 9	Aswan 76
British Control in Egypt During the 1920's 11	
Welcome!13	People in Egypt78
Cost of Living 13	Who's Who in the 1920's 78
Getting Around 13	The Bedouin of the Deserts 80
Hotels 16	Secret Groups 82
	Magic in Egypt 83
The Sights of the City21	Gods of Ancient Egypt85
The Ezbekiya 21	
Medieval Cairo 23	Glossary95
Citadel of Cairo 29	
Old Cairo 31	Bibliography99
Museums 33	
Mosques 37	Index100
Hospitals and Asylums 41	
Coffee Shops 42	
Universities 44	
Animals 48	
Cemeteries 50	
The Darker Side of Cairo 56	



The Cairo Guidebook is published by Chaosium, Inc.

The Cairo Guidebook original manuscript © 1995 by Marion Anderson; all rights reserved. Additional material © 1995 by Chaosium, Inc.; all rights reserved.

Call of *Cthulhu*® is the registered trademark of Chaosium, Inc.

Similarities between characters in The Cairo Guidebook and persons living or dead are strictly coincidental.

Chapterhead quotes are from "Imprisoned with the Pharaohs", in *The Tomb and Other Tales*, by H. P. Lovecraft. H. P. Lovecraft's works are © 1963, 1964, 1965 by August Derleth and are quoted for purpose of illustration.

Special thanks to Chris Williams of R. Talsorian Games, Inc. for researching the Arabic proverbs, and for allowing use of his work in this book.

Except in this publication and in related advertising, artwork original to *The Cairo Guidebook* remains the property of the artists, and is copyright by them under their separate copyrights.

The reproduction of material from within this book for the purpose of personal or corporate profit, by photographic, electronic, or other methods of retrieval, is prohibited.

Address questions and comments concerning this book as well as requests for free catalogs of Chaosium books, games, and supplements to Chaosium, Inc., 950-A 56th Street, Oakland CA 94608-3129, U.S.A.

Chaosium Publication 2351. Published in May 1995.

ISBN 1-56882-025-9

Foreword

Cairo and Egypt are very much a **part of international** life and gossip in the 1920's. Few people are **unaffected by the romance and glamor** attached to the ancient pharaohs of Egypt.

The opening of the tomb of **Tutankhamun** in November 1922, and the breathtaking beauty of the treasures within, sparks a wave of Egyptomania **that** washes over the entire world. Egyptian jewelry is worn by flappers and dowagers alike; men wear tarbouches to work on Wall Street and smoke hashish from nargeeleh water pipes. The animalistic motifs of ancient Egyptian **art** are blended with the clean lines of **Art Nouveau** to create a whole new interior decorating style.

Archaeologists flock to the Valley of the Kings to take part in excavations that can make or break a career. Many others gather there to share the excitement of the daily uncovering of more treasures of the past. Many artisans make fortunes from copies of tomb items sold as genuine artifacts. Others make a fortune from stealing and reselling artifacts to private collectors.

The interest in Egypt extends to secret societies, who incorporate ancient Egyptian rituals into their ceremonies and attract many of the gullible with promises of ancient magics and eternal life. Many send representatives to visit Cairo and Egypt in order to gain the secret knowledge of the ancients.

Cairo, the capital of Egypt, profits from the attention of the rest of the world. Tourists fill its hotels and its bazaars. However, the 1920's are a time of turmoil, with frequent riots and political killings. Egypt is in the transition between British rule and self government. Members of rival political parties fight each other in the streets.

Investigators visiting Cairo in the 1920's are thrown into the middle of a powder keg of political intrigue in a city of ancient romance. This is a time rich in high adventure, a time of anarchy gradually becoming order. It is a time when guns can be carried openly in the streets by Westerners, but are forbidden to locals.

Amid all the chaos is the allure of the city of Cairo itself. This is the city of the Arabian Nights, a city with a storyteller on every **street** corner **and** jugglers **and** snake charmers plying their trade. It has the largest bazaar district of any in the world. This is a city of danger in **true** storybook style, where **white** slavers still kidnap young foreign women, and respectable **Cairene** women travel the streets veiled and swathed in secrets.

Many adventures await the investigator in Cairo. This book provides Keepers with all the details needed to bring Cairo and Egypt in the 1920's alive in the minds of their players: from the **first arrival** on the shores of Egypt to train trips up the Nile; from where to stay and eat, to the inhabitants and smells of the bazaars. Museums, universities, and secret societies are all described. Also included are the gods of ancient Egypt, their magic and their worshippers. Beyond Cairo the lure of ancient Egypt beckons the investigator, its ancient temples to forgotten gods testimony to the decay of all things made by man, and to the futility of man's striving towards immortality.

Please note: The Cairo in this book is very much the real 1920's Cairo. Historical facts and figures are given as they were known in the 1920's (with some modern information in parentheses), and attitudes stated reflect those of the people of the 1920's. In many ways Cairo is now a very different city. Keepers may especially wish to soften the **attitudes** of locals towards women in their versions of Cairo.

Thanks to David **Godley** for extra last-minute research, to Richard Watts for the Brotherhood of Seth, and to Mark and Penny for getting me into this in the first place and **making** me stick to it! Extra thanks to Phil, Rusden and **Taran** for keeping me vaguely sane throughout.

This book is dedicated to my grandfather, who had an office off the **Muski**, and to my father, who played in the streets of Cairo as a child. I wish I could have been there with them!

— Marion Anderson

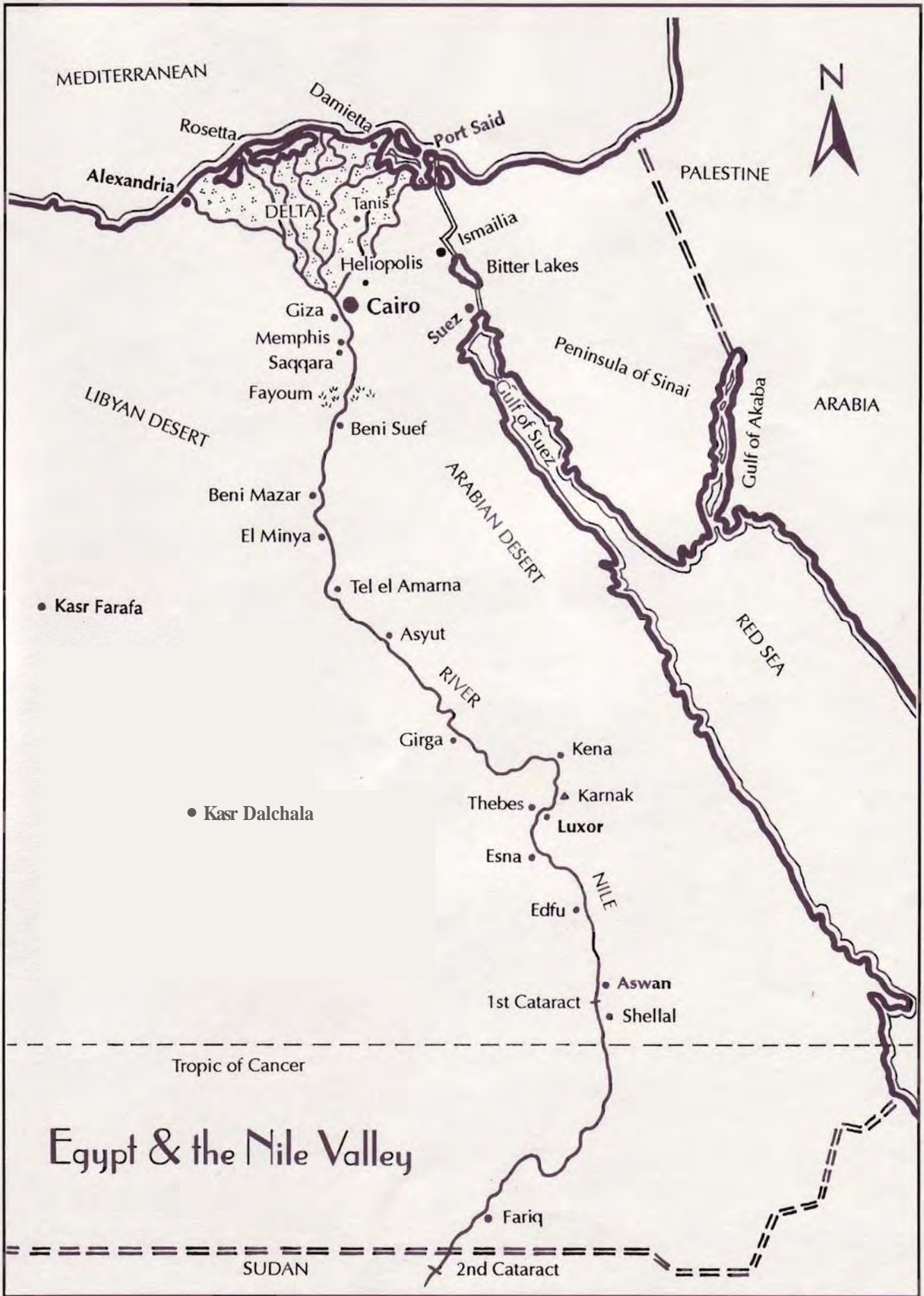

Egypt & the Nile Valley

SUDAN

2nd Cataract

1st Cataract

Aswan

Shellal

Edfu

Esna

Luxor

Thebes

Karnak

Girga

Kena

Asyut

RIVER

Tel el Amarna

El Minya

Beni Mazar

Beni Suef

Fayoum

Saqqara

Memphis

Giza

Cairo

Heliopolis

Ismailia

Bitter Lakes

Tanis

Port Said

Damietta

Rosetta

Alexandria

MEDITERRANEAN

PALESTINE

N

ARABIA

Peninsula of Sinai

Gulf of Akaba

Gulf of Suez

ARABIAN DESERT

LIBYAN DESERT

RED SEA

Tropic of Cancer

Going to Cairo

"I drifted pleasantly down the Continent and embarked at Marseilles on the P. & O. steamer Malwa, bound for Port Said."

Getting There from Here

Why travel to Cairo? It is a city of antiquities, gateway to the lands of the ancient gods. Where better to search for rare or previously unknown **Mythos** tomes and artifacts? The pharaonic deities of Egypt have, over the millennia, been overcome by newer gods, but perhaps there are other, older gods that walk the shifting sands of the great deserts surrounding Cairo: gods waiting for those who believe to find them once more.

Cairo is a city of markets, of bazaars, of people skilled in the art of selling and of **finding** things to sell. Here can be found all the treasures of the known world, and perhaps treasures of worlds waiting to be known.

Traveling to Cairo

The investigator arriving in **1920's Cairo** will most commonly have reached Egypt by **sea**, through the **Nile Delta** ports of Alexandria or Port Said. From both of these **ports** steam-driven passenger and freight trains run frequently to Cairo, the **trip** taking approximately half a day and costing 131 Egyptian piastres (**P.T.**) for first class, and 77 P.T. for second class. **Many** of these trains are run and owned by the **steamship** companies they **meet**. **Arrival** to Egypt by land commonly involves a train journey through Palestine, **possibly** on the extension of the Simplon-Orient Express.

Travel to Egypt by car is highly unusual, as roads through Palestine to the east and Libya to the west are **virtually** nonexistent. These areas are more commonly traveled by camel caravans.

Air travel is rare but possible in the early **1920's**, only being commonplace by 1929, with an airstrip being built at **Dikheila** south of Alexandria in that year. There are infrequent Imperial Airways flights from the Heliopolis Aerodrome to India and London from 1925 on.

Travel from London or New York by sea is via the Straits of Gibraltar into the Mediterranean Sea, with most vessels stopping at Marseilles and one or two other Mediterranean **ports** before arriving at Alexandria or Port Said. Most stopovers are of three to five hours' duration, but

breaks in the **journey** can be made at any of the **ports** visited, with the voyage continued on the next ship of the same line to visit (this may be three weeks in **some cases**). Small tramp steamers can be chartered at any port in the **Mediterranean**, at a **cost per passenger** half that of a liner. The surroundings, however, are far **from salubrious**, and the ship owners are not always above **offloading** foreign passengers at gunpoint and **departing** with their belongings.

TO CAIRO ON THE ORIENT EXPRESS

The most common route used for land travel from **Europe** is the extension of the Simplon-Orient Express, **from** London to Calais, Paris, **Lausanne, Simplon**, Milan, Venice, Trieste, Belgrade, Sofia, and ending in Constantinople. From Constantinople a ferry boat carries passengers across the **Bosphorus**; they then travel by railway to **Tripolis** (Syria), where they are carried by automobiles of the International Sleeping Car Company to either Haifa or **Jaffa** in Palestine. Next is a hip by railway to Qantara **East**, where they cross the Suez Canal by ferry and board the final train to Cairo.

The **trip** from **Calais** to Cairo takes one week in total, with average costs from London of **first class 44£/15s/7d**, and mixed class (first class London to Paris and **Tripolis** to Qantara, second class the rest of the way) **35£/5s/9d**. **Fares** from Calais are two to three **pounds** cheaper. All of these prices include the sleeping **car** supplement. The extension service runs twice weekly from Constantinople, on Mondays and Fridays. The **service** delivers, as always, the utmost in luxury, with sleeping berths provided even on the automobile section of the journey. There are silver service meals and fine entertainment; your assigned conductor stays with the group until it reaches the **final** destination and ensures that you are not bothered by the **riffraff** in the stations. Enterprising Keepers may wish to use some of the material supplied with the **Horror on the Orient Express** campaign for inspiration.

Traveling by sea can vary **from** extremely luxurious (first class on the **P&O**, White Star, or Orient Lines) to squalid (tramp steamers chartered at any Mediterranean port). The first class traveler is wined and dined and can dance the night away or gamble in casinos among the rich and famous bedecked in evening gowns and dripping with diamonds. The steerage passenger is lucky if he sees daylight from his cabins, and is restricted to the lower dining areas, where the food is



Travel Information

Average sea travel times to Alexandria or Port Said from:

- London: 12 days to port plus half a day train trip to Cairo
- New York (also Boston or Providence): 3 weeks
- Medierranean ports:
 - Marseilles: 5 days
 - Genoa: 6 days
 - Constantinople: 4 to 12 days (**direct** or mail run)

Average sea passage fares from:

- London (UK £): 1st class **38**, 2nd Class **24**, 3rd Class **16**
- New York (US \$): **300**, - , **160** (2nd class not available)
- Mediterranean ports (UK £):
 - Marseilles: **24, 16, 12**
 - Genoa: **29, 19, 11**
 - Constantinople: **20, 12, 9**

Fares to Port Said are usually 2 LUK more than to Alexandria when traveling east, and *vice versa* when traveling west. Discounted fares are provided by some carriers in the low season of April to August.

Companies providing sea travel services to Egypt (in descending order of luxury and cost):

- from London to Port Said:
 - Pacific and Orient Line (**P&O**) (each Friday)
 - Orient Line (every second Saturday)
 - Nippon **Yusen Kaisha** (fortnightly)
 - British India Steam Navigation Co. (**3-4 times** monthly)
 - Union Castle Line (monthly)
 - W from London to Alexandria:
 - Prince Line (every 3 weeks)
 - from New York to Alexandria and then to Port Said:
 - White Star Line (monthly)
 - Ellerman & Bucknall** Steamship Company (monthly)
 - Fabre Line (monthly, via Boston and Providence)
 - from Mediterranean ports to Alexandria:
 - Sitmar** Steamship Company (twice weekly, SS *Ausonia* and SS *Esperia*, Genoa, Naples and Syracuse)
 - Prince Line (weekly. **Constantinople** to Alexandria **direct**)
 - Khedivial **Mail** Company (fortnightly; Constantinople to Port Said, stopping at all minor towns)
- All of the London and New York carriers stop at Marseilles and Gibraltar; the Fabre Line also stops at Constantinople.

adequate but never glamorous. A charter passenger may share the hold with salted fish and rats.

Custom inspections at Alexandria and Port Said are rigorous, and **permits** are required for firearms and explosives. After 1925 the **import** and **export** of **drugs** is prohibited, with death the usual penalty for **traffickers**. There is always a chance, however, that the **inspector** may be **bribeable**.

The export of antiquities is usually prohibited, but licenses **are** available from the Egyptian Museum for genuine **items** **deemed** to be of little interest (there is a thriving underground **trade** in these licenses). **On** leaving the country a sanitary **tax** of 20 **P.T.** and passport duty of 2 **P.T.** are payable.

SIGHTS AND SOUNDS

On arrival in Egypt the traveler is immediately struck by the number of people at the stations or ports. Arriving **ships** are met by flotillas of **small**, unseaworthy and overloaded **craft**, each bearing the banner of a major or **minor** hotel or travel business. Each hotel in the city or port has its representatives touting for business: Tourist guides ("dragomans") extol the virtues of their abilities, porters and carters squabble over luggage being unloaded, and water sellers push through **the** crowd to be **the first** to sell the newcomer a "taste of the **Nile**", a treat that usually results in incapacitation for up to seven days. The water sellers usually have cousins who sell tonics that purport to remove these symptoms.

An arriving investigator not only has to get through customs, he then has to wade through the press of human flesh to fight for his luggage and retrieve it from as many **different carriers** as he has bags. Major hotels and travel agencies, such as **Shepherd's** Hotel and Thomas Cook & Son, have a well-ordered baggage handling service, and investigators need not concern themselves with their bags once they pass through **customs**—**they** appear miraculously at the hotel before the investigators do. In other cases, there is a good chance that at least some of their belongings go astray.

These crowds **are** also the ideal cover for pickpockets. Small items in external pockets may never be seen again.

At the ports a strong smell of fish is omnipresent, and at times in midsummer (June to August) quite nauseating.

DRAGOMANS

These tour guides range in age from 12 to 70, and are invariably Arab males. **Their** ability to speak English (or other European languages) is the **determining** factor on their cost, and bears no relationship to their knowledge of the city. The best come recommended by the hotel the investigators **are** staying in; the worst are **the** unlicensed dragomans that surround the **unescorted** investigator in the street touting for business. There is always a chance that **some** may be thieves and cutthroats.

Investigators can expect to pay 30 **P.T.** per **half-day** and 40 **P.T.** per day for the best, with most hotels able to add this charge to their bills. The official charges for a licensed dragoman are 8 **P.T./hour**, 20 **P.T./day** in Cairo, and 30 **P.T./day** outside of Cairo. Lists of licensed dragomans **are** available at good hotels. Few dragomans are available on public or religious holidays (see page 40 for religious holidays).

The main use for dragomans is in gaining permission for investigators (males only) to enter mosques, and in finding shops for investigators to purchase needed supplies from. Such establishments **are** generally run by **rela-**

tives; the observant investigator will begin to notice family similarities after a while. Dragomans hold the monopoly for hiring almost anything to tourists. It is possible to hire animals and other services without a dragoman, but it is not advisable, as the odds are increased that you are hiring from thieves who will rob you blind.

Saleem Naziz

Saleem is a professional dragoman. His family has worked as guides to tourists for many generations. He takes his profession seriously and is scrupulously honest and forthright. He has traveled extensively within Egypt, and knows Cairo better than he knows the back of his own hand.



SALEEM NAZIZ, Dragoman, age 25

STR 12 CON13 SIZ 10 INT 14 POW11
DEX 11 APP 12 EDU 14 SAN 55 HP 12

Damage Bonus: None

Weapons: Dagger 50%, damage 1d4+2

Rifle 45%, damage 1d6+2

Club 40%, damage 1d6

Skills: Archaeology 15%, Bargain 60%, Climb 60%, Fast Talk 65%, History 40%, Natural History 15%, Navigate 80%, Ride 40%, Track 20%; Languages: Arabic 70%, English 30%, French 25%, German 25%

Egypt's Seasons & Climate

Egypt and Cairo are dry and hot, with typical desert conditions. It is only the presence of the Nile River that makes Egypt inhabitable. It almost never rains. Days are almost always sunny, clouds rarely appear, and nights are crisp and cool with the infinite stars blazing overhead.

In the desert the sun becomes the travelers' worst enemy. They are scorched and desiccated by day, with temperatures commonly exceeding 110° F (42° C). By night they are chilled to the bone, with temperatures dropping to near freezing when skies are clear.

The high season for tourists in Cairo is late autumn to early spring: November to the end of April. Temperatures during this period are comfortable, and cooling breezes flow in from the desert every evening. This is the season for archaeological digs, for Nile cruises, for dancing all night beneath the stars. In summer the richest Egyptians move to Europe to escape the endless heat.

Summer in Egypt is a time of long rests between midday and late afternoon. All shops close during these hours, and locals rest at home in tiled courtyards cooled by the spray of central fountains. This is the best time for painters and photographers to visit Egypt and Cairo. The light has an incredible clarity and shadows are crisp and sharp. In the cities, days are hot and often oppressively humid. Clothes become drenched in sweat; the slightest exercise is exhausting. There is an almost audible sigh of relief from the inhabitants of Cairo when the stifling heat of the day turns to the cool of the night.

Average Temperatures in Egypt (Day/Night) in Fahrenheit

	Winter	Spring	Summer	Autumn
Alexandria	69/51	80/58	86/69	86/62
Cairo	69/51	90/51	96/68	89/57
Luxor	79/42	103/50	107/72	103/54
Aswan	79/149	103/57	108/77	103/51

TIME ZONES

Noon (12:00 midday) in Cairo is:

2:00 a.m. in San Francisco

5:00 a.m. in New York

10:00 a.m. in London and Paris

11:00 a.m. in Rome

8:00 p.m. in Sydney and Melbourne

Money

Egypt uses a decimal currency system. The standard units of currency are the Egyptian pound (£E), the piastre (P.T., 100 to the £E), and the millieme (mill., 10 to the P.T., 1000 to the EE). The £E is a gold coin, the P.T. is a silver or nickel coin (the nickel is more commonly found in circulation), and the mill. is a nickel or bronze coin (bronze is common). Individual coins are also used for the half EE, the double P.T. (2 P.T.), the half P.T. (1/2 P.T., 5 mill.), 2 mill., and 1/2 mill.

Standard rates of exchange during the 1920's vary constantly. Travelers will usually get more for their foreign currency with money changers in the market place than at banks, but they may later find the coins they have been given by street money changers are worthless.

Average Exchange Rates

	British shillings, pence	American \$, ¢	French francs, centimes
£Egyptian	2016	\$5.00	25,92
Piastre	0/2-1/2	\$0.05	0,26
Millieme	01114	\$0.005	0,025

Alexandria

Alexandria is the oldest major port in Egypt, founded in 331 B.C. by Alexander the Great during his conquest of Egypt. The Greek city and port was a focus for artists and scholars. The lighthouse on the island of Pharos was one of the seven wonders of the ancient world,



and the legendary Library of Alexandria is said to have once contained all of the knowledge of the ancient world. Its 700,000 volumes were largely destroyed with the bulk of the library by fire in 391 A.D. The final destruction of its remains took place at the orders of Caliph Omar in 640

MEDITERRANEAN SEA

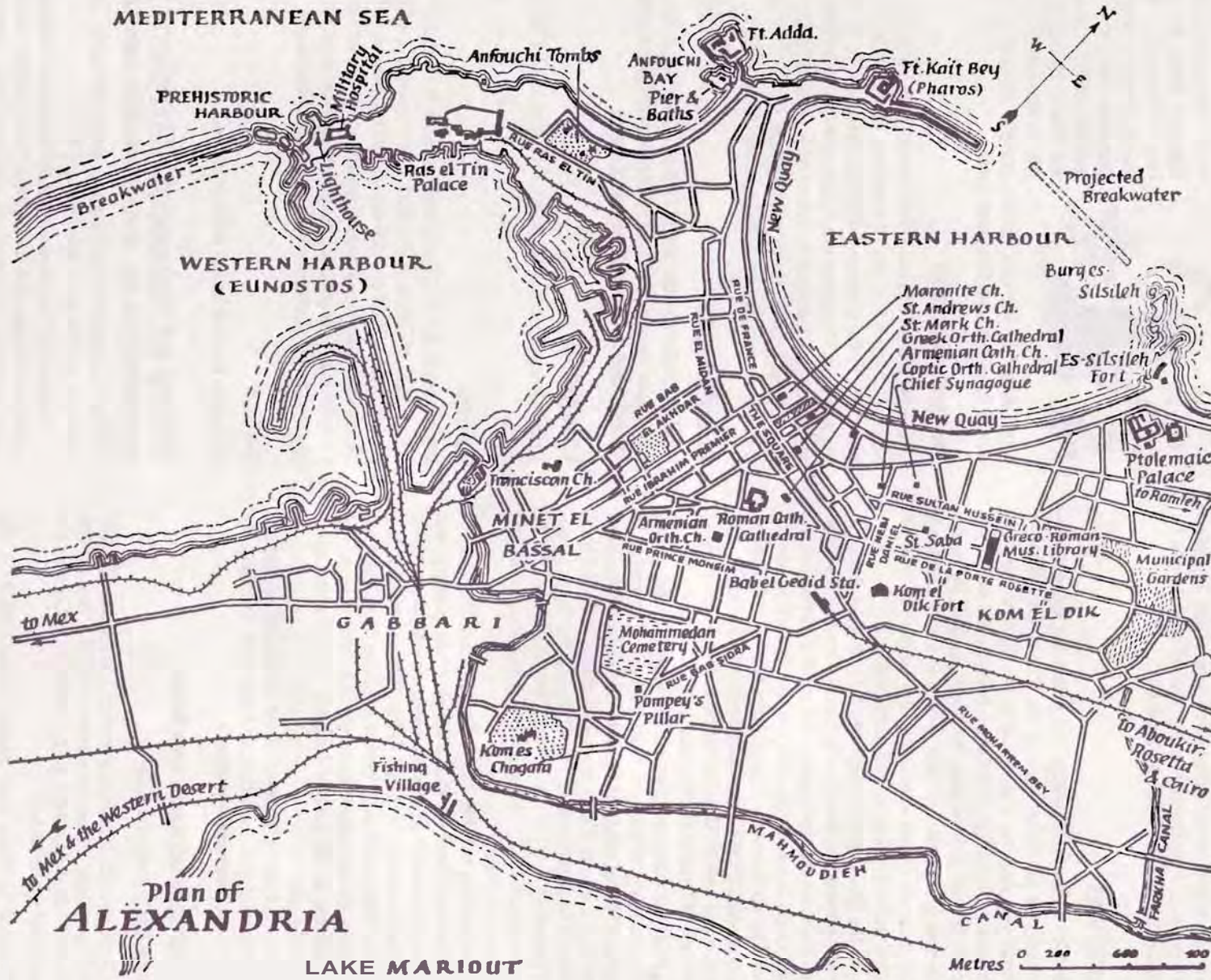

Plan of ALEXANDRIA

LAKE MARIOUT

A.D. Rumors persist that some volumes of ancient lore, looted before the ~~fire~~, may still exist hidden in the city.

While foreign tourists flock to Cairo during the high season (the winter months), the rich and powerful of Cairo move to Alexandria for the summer. Here they occupy their summer houses, bask on the sandy beaches, and party the nights away. Most members of the Egyptian parliament and diplomatic **attachés** of all nations *can* be found here between June and September.

Arrival

The first sight of Alexandria that greets the **seaborne** investigator is the white walls of the Ras **el-Tin** palace, a fortress that rises on a headland to the right of the ship, just above the modern lighthouse built on the site of the ancient temple to Poseidon. At dawn or dusk the walls glow red, and some say they appear to **run** with blood. (The palace is closed to tourists after early 1925 while it undergoes renovation by Italian craftsmen.)

As the investigator's ship sails into the inner harbor to berth, it passes two warships berthed here since the Great War. Immediately, **the** vessel is surrounded by numberless small boats representing every travel agency known to man. The air becomes vibrant with Arabic and English exhortations: "Take up a tour with our agency!", and "Stay at our hotel!" The view from on deck is like looking into a pit of lions at feeding time.

Railway tickets to Cairo are available from the purser before landing; during the tourist season (November to late April) trains run **from** Cairo to meet all **arriving** ships. Trains also **run** to Cairo from the central **Bab el-Gedid** Station. The express takes 3 to 3-1/2 hours to Cairo; standard takes 6 to 7-1/2 hours. Fares: first class 1 **£E** 23 P.T., second class 66 P.T.; dining and **pullman cars** are attached to express services.

The railway to Cairo (130 miles) follows the course of the **Khandaq** Canal for the first half of the journey, and fellahin (farmers) can be seen along its length, **pumping** water and working irrigated fields. The second half follows the Nile, and shortly before reaching Cairo the ruins of Heliopolis **are** passed, although little can be seen. The train **arrives** at the Central Railway Station at the north end of the city.

Representatives of most of the steamship companies arriving in Egypt have **offices** in Alexandria, and there **are** British and American consulates.

ACCOMMODATIONS AND FOOD

Alexandria's hotels include:

- **Claridge's** (35 Rue **Fuad** Premier; 150 rooms, 120-180 P.T. per night, motor from harbor 40 P.T.), fine accommodations with a roof garden looking out across the city and to the harbor.
- **Majestic** (4 Place Saad Zaghlul [before 1925 "4 The Square"]; 200 rooms, 100-150 P.T. per night), good accommodations.

- **Hôtel de France** (west side Place Saad Zaghlul ["The Square"]; **50** rooms, 20-30 P.T. per night), cheap accommodations.

Aside **from** the excellent hotel restaurants, **good food** can also be obtained at **Giovannides** (33 Boulevard Saad



Zaghlul), which serves both European and Egyptian food, **the** Union (2 Rue de l'**An-cienne** Bourse), *serv*ing European food; and numerous Arabic *cafes* in the Place **Muhammed** Ali. A number of "**beer**

restaurants" in the city center provide lager beer and mixed Egyptian and **European** food.

TRANSPORTATION

Transport around Alexandria is provided by horse-drawn carriages (3 to 6 P.T. per 10 minutes), motor taxis (3 P.T. per mile), or the extensive tramway system (5 to 10 mill. per journey). Most places in Alexandria can be reached by a tram journey followed by a short **walk**; women must ride in a separate compartment on **the** trams. Each of the tram routes is denoted by a colored symbol on the tram.

BOOKSELLERS

Mr. L. Schuler (6 Rue Sherif **Pasha**) sells antiquities and rare **books**. **Spiros N. Grivas** (11 Boulevard Saad Zaghlul) sells old and new **books** and travel maps.

LIBRARIES

British Book Club (5 Rue Adib), **9:00** a.m. until **1:00** p.m. daily.

SHOPS

Davies Bryan & Co. (Rue Sherif Pasha), S. **Sednaoui** & Co. (Rue Sidi el-Mitwalli), and Rothernberg's (Place **Muhammed** Ali) all **provide** expedition supplies as well as clothes and European goods. Egyptian goods *can* be bought from the many shops lining the Rue Sherif Pasha; **prices** are probably highly inflated unless bought by a dragoman.

BANKS

All major English **banks** are represented.

Sites of Interest (Ancient) POMPEY'S PILLAR, SERAPEUM AND LIBRARY

Via the Karmous Tram (symbol: green lozenge). Open **9:00** a.m. to **5:30** p.m.; admission is 3 P.T.

Pompey's Pillar at the ruins of the **Serapeum** (the temple to the god **Serapis**, a **Greek** blend of **Osiris** and **the** bull god **Apis**, later part of **Mithraism**) **marks** the spot where the **Library** of Alexandria once stood. The pillar was believed to have been erected on the **ruins** by **the** **Byzantine Emperor Theodosius** in 391 A.D., to **mark** the **conquest** of **Christianity** over the old pagan **gods** and knowledge: During **the** middle

ages it was thought that the pillar also marked the site of the tomb of **Pompey** the Great, the Roman general responsible for the crushing of the slaves' revolt led by Spartacus. Pompey (**Pompeius Magnus**) was assassinated as soon as he set foot on Egyptian soil in Alexandria (48 B.C.) by one of his most trusted **centurions**.

The most recent excavations here took place between 1905 and 1907, with the bulk of the excavating having **occurred** between 1898 and 1902. Near the pillar are an ancient water basin, two sphinxes of red granite, and a number of headless figures, all of which **are** thought to have been brought here from Heliopolis by Alexander the Great. Fifty-five yards west of the pillar are a number of granite columns marking the entrance to the subterranean passages that are all that remain of the library and **Scrapium**. A flight of wooden steps leads down into an open court where passages lead off to the north and south; small niches line the passages, which end in rubble falls.

Scenario Hook: These passages have never been fully excavated or explored.

CATACOMBS OF KOM ESH CHOGAFA

A ten-minute walk from Pompey's Pillar towards the canal, these were only discovered in 1900. Entry fee is 5 P.T.

The well preserved tombs at Kom esh Chogafa (Hill of Potsherds) blend Egyptian and Classical **Greek** designs, and are thought to have been built around the second century A.D. Their size and the eerie sculptures within **make** a profound impression on all who visit them. The main tomb consists of three levels of catacombs reached by stairs; this tomb lies at the bottom of a black, glassy-walled well shaft. Due to the proximity of the tombs to the **Mah-moudieh Canal**, the lower of the two levels open to the public is often partially flooded. The third level is always flooded and has never been explored.

Another tomb can be entered by a break in the wall of the rotunda, and there **are** four additional tombs that can be reached from separate stairways nearby. Above ground, the **excavation** is a hill of rubble, strewn with fragments of broken tiles and a largely ruined mosaic of black and white stones. The pattern of this mosaic is unknown. Before the entrance to the tombs is

reached the investigators pass four immense sarcophagi of purple granite, all in excellent condition.

The tomb decorations show a bizarre mixture of **Roman**, Greek and Egyptian themes, with statues of Anubis and Sebek in centurion armor guarding the main tomb chamber; huge stone serpents bearing **the** beards and crowns of Upper and Lower Egypt; the enfolding pine cones of Dionysis and **the** winged **rods** of Hermes; and sarcophagi intricately carved in Egyptian style but with the heads of medusae. More than four hundred mummies would have been here originally; most have been looted over the years, with **the** few surviving on display in the Museum of **Greco-Roman** Antiquities.

Scenario Hook: The unexplored and inundated level is a tomb dedicated to Father Dagon, used by a community of deep ones since ancient times. It is connected to the sea via the adjacent canal.

ANCIENT HARBOR (1300 B.C.)

This harbor from 1300 **B.C.** was thought to have been built by **Rameses II**, but has also been attributed to the Minoans and to the lost culture of Atlantis. It may also be one of the harbors mentioned in **Homer's Odyssey**. The harbor was used by pirates during the 13th to 15th centuries A.D.

Investigators who hire a small boat and row out just past the modern breakwater **will** be able to see the ruins of the harbor walls and many colonnaded buildings a further ten yards out under the water, at depths of 4' -25'. These structures were partially excavated in the mid-1800's, but not fully explored.

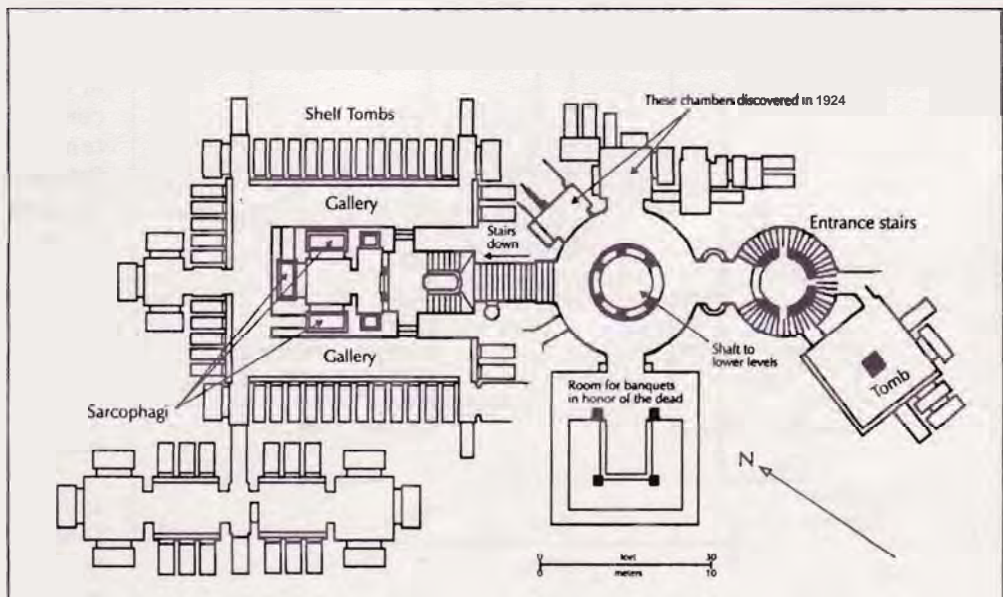

Kom esh Chogafa Catacombs

Scenario Hook: What enigmatic—even horrific—statuary may be revealed in the morning if the covering sand is washed away by a storm the previous night?

FORT KAIT BEY AND THE PHAROS

The Pharos can be reached via the Circular Tram (symbol: green triangle); this goes past the Ras el-Tm palace and the ancient harbor to the Fort. This tram then completes the circuit to the Catacombs and to the modern inner harbor.

The fabled lighthouse (or "pharos") of Alexandria stood where the Fort of Kait Bey—a impressive high-walled medieval fort—now stands. The lighthouse, built in 279 B.C., stood more than 400' high, contained all the technology known to science, and stood intact until 700 A.D. Legend says the lighthouse sat on a giant glass crab and that atop the lighthouse was a "magic mirror" that was

able to detect enemy ships at a distance and, some say, destroy them. Stories also tell of an invading force of horsemen determined to seek out the secret of the mirror who lost their way in the "three hundred rooms" below the lighthouse, and who were eventually devoured by the crab. Following a series of earthquakes from 700–1400 A.D. all that remains is a mosque (open rooms with wood latticework) built in the late 1100's on the rubble of the lighthouse, and the adjacent Arabic castle built in 1480 and damaged by British bombardment in 1882.

Scenario Hook: What lies in the three hundred rooms accessible through the rubble beneath the mosque? What is the great glass crab and how do you awaken it? What was the power of the mirror? Can any of these secrets be unearthed, and at what cost?

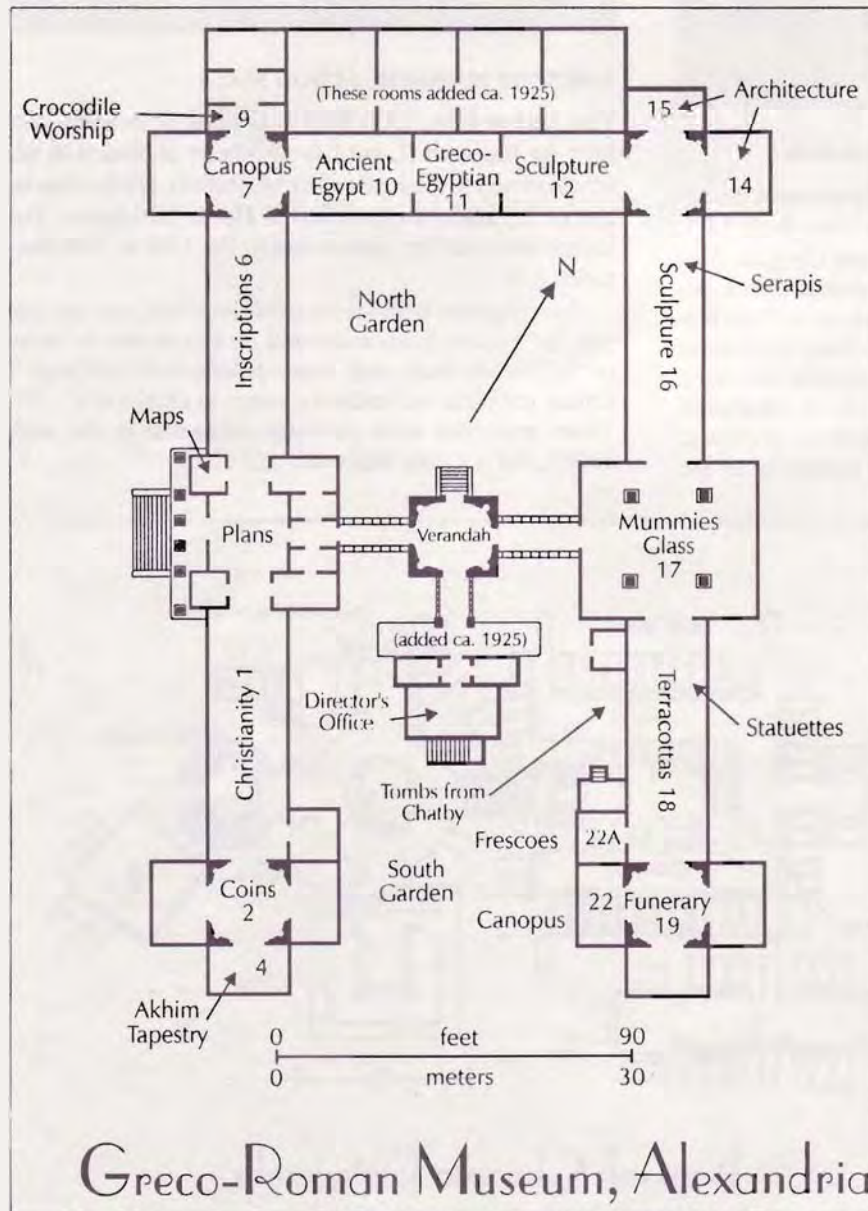

Sites of Interest (Modern)

MUSEUM OF GRECO-ROMAN ANTIQUITIES

Rue de Musée, adjacent to the town hall; established 1903. Open from 9:00 a.m.–12:30 p.m. and 3:00 p.m.–5:30 p.m. daily; admission is 2 P.T. Combination tickets may be bought here (8 P.T.) for the Museum, Pompey's Pillar and the Catacombs.

The museum contains the best artifacts from the Greco-Roman occupation of Alexandria, although ancient Egyptian relics can be found in rooms 7, 8, 9, and 10. Room 9 contains items from the Payoum temple to the crocodile god Petesouchos. The Fayoum was an irrigated area southwest of Cairo where Greek and Egyptian gods mixed, their worshipers taking the worst aspects of both pantheons. In the center of the room is a mummified crocodile on an ornate wooden stretcher atop a wooden chest. Many find this room and its contents unsettling.

The museum director is Professor E. Breccia. He is an expert on Greco-Roman Alexandria and can be found in his office during open hours.

Greco-Roman Museum, Alexandria

Scenario Hook: Among the newly acquired Fayoum artifacts is an item that is the most valued artifact of the petesouchi (the crocodile people of the Nile). They have recently learned of its presence here and are traveling down the Nile to take it back to its traditional shrine. Their travels take them through the lands of their traditional enemies, the deep ones. The fights between them are to the death, the bodies of the dead being washed down the Nile.

MOSQUE OF THE PROPHET DANIEL

Rue Nebi Daniel: walking distance from accommodations. This mosque is said to stand on the site of the tomb of Alexander the Great. The cellars of the mosque have never been explored.

The stairs to the basement lead to two tombs, identified as those of the prophet Daniel and Lukman the Wise (a legendary, possibly fictitious, scholar). It is unlikely that either tomb holds whom it claims to.

Scenario Hook: The investigators' dragoman says that the body of Alexander still lies in a glass sarcophagus beneath the mosque. He insists it's true; his grandfather—a dragoman for the Russian Consulate in 1850—peered through a hole in a wooden door and there saw a body clad in gold sitting on a throne, with the crown of Alexander on its head, and around its feet were scattered hundreds of papyrus scrolls.

If disturbed, Alexander will prevent the scrolls from being taken or read (treat him as a mummy; see *Call of Cthulhu* 5.1 page 133). These are the forbidden scrolls from the Library, "things man was not meant to know", and they are under his protection. Among them is a scroll of water breathing.

Scenario Hook: A secret passageway may be opened by attempting to lift the lid of the tomb of Lukman the Wise—perhaps a passageway to the scrolls of Alexander and ancient wisdom?

Port Said and the Nile Delta

We had come to Egypt in search of the picturesque and the mystically impressive, but found little enough when the ship edged up to Port Said and discharged its passengers in small boats. Low dunes of sand, bobbing buoys in shallow water, and a dreariness European small town with nothing of interest --"Trapped with the Pharaohs"



Port Said

The Egyptian port used by the majority of passenger vessels from England, Port Said is at the easternmost edge of the Nile Delta, and is the entry point to the Suez Canal. The town, founded in 1859 and named after Said Pasha, is built on top of a mud bank formed of canal debris. It is an unimpressive and uninspiring place, where the offices of the Suez Canal Company stand out as architectural



P. & O. and B.I. AGENTS—THE ENGLISH COALING CO., LTD

jewels. It is in no way a typical Egyptian town, largely existing to service the canal and the ships that pass through it.

Representatives of all the steamship companies operating in Egypt have offices in the town, and there are British and American consulates. Port Said is laid out in grid fashion and is largely uninteresting, with no ruins of note.

As ships approach the harbor, the low rolling sandhills of the coast are apparent, and the sea is muddy with silt from the Nile. Ships do not berth at the pier; passengers disembark via a flotilla of small craft (2-4 P.T. per person, 1-112 P.T. per trunk). Some shipping companies and the major Cairo hotels can arrange for the handling and landing of all luggage for a fee. Customs inspections take place once ashore (see Alexandria for customs regulations and departure taxes).

TRANSPORTATION

Horse cabs and motor cabs are available for the same fares as in Alexandria (see page 6). A limited tramway runs through the town.

Trains to Cairo (148-112 miles) depart from the railway station, ten minutes' walk west of the Customs House. Express trains take 4-112 hours, and ordinary trains 4-314 hours (there are few stops). The fare to Cairo is 135-112 P.T. first class. 73 P.T. second class. Dining cars and pullman cars are attached to express services.

The train to Cairo follows the Suez Canal, with Lake Manzala to the right, and connects with the Palestine Railway at Qantara (Orient Express passengers join the train here). At Qantara trains can be boarded for the journey to Jerusalem via Gaza and Ludd (9-1/2 hours), and to Haifa (10 hours). The train runs along an embankment and then (at the 48-mile mark) turns inland and southwest to the town of Ismailia, the site of a large British garrison. The journey continues through fertile irrigated land into an area of stark desert and then back into irrigated land as it joins the Alexandria line (120 miles) and then into the Cairo Central Railway Station.

HOTELS AND RESTAURANTS

Eastern Exchange (Shari Fuad el-Auwal; 80 rooms, 80 to 100 P.T.), good quality.

Casino Palace (North Shore; 85 beds, 60 to 150 P.T.), good quality, some rooms with balconies facing the sea.

- Hôtel de la Poste (27 Shari Fuad el-Auwal; 60 rooms, 70 to 90 P.T.), average quality.

There are some Arabic restaurants in Port Said. Most foreign visitors eat at the hotel restaurants.

SHOPS

An abundance of artifact vendors crowd the streets; almost all sell fakes as originals. Real antiquities can be found at Simon Arzt's, and good quality Chinese and Japanese antiques can be bought from either Au Nippon (prop. Fioravanti & Chiminez) or Au Mikado (prop. G.



C. Sarolides). Newspapers and novels can be found, but no rare or unusual books.

The Suez Canal

The Suez Canal links the Mediterranean with the Red Sea. It is 101 miles long and was completed in 1869, having taken ten years to build. The first part of the canal, starting at Port Said, runs almost due south to Ismailia, and then follows the route of a canal originally built in 500 B.C. by Darius I of Persia. The controlling interest in the canal was bought by Britain in 1875, and it is still run by the British government in Egypt.

Scenario Hook: Ships using the canal begin reporting strange sightings and attacks on their passengers and crews during the night. One or two ships have even been sunk; some say that it's just pirates. In actuality, a deep one colony has dwelt in the Red Sea since time immemorial. The construction of the Canal caused a great deal of environmental disruption to their domain. After many years, they have regained strength, and begin to attack—even sink—ships using the resented canal.

The Nile Delta

The vast delta at the mouth of the Nile River is the breadbasket of Egypt; almost all food consumed in Cairo is grown here. The delta was formed by the silt carried down the Nile on the annual floods, the new layers of fertile river mud rejuvenating the farmlands. Every arable inch is farmed, with rice, cotton, date palms, maize, wheat, barley, beans and other grains visible from the trains. Irrigation canals and wells run through the fields and water is pumped constantly onto the crops by the fellahin on treadmills, or by oxen, mules, horses or camels harnessed to windlasses. The fellahin usually wear loose shirts and trousers, although when working in the fields they often resort to only a small breechcloth.

Most fellahin are able to harvest twice each year instead of the single harvest possible in most other places in the world. During these harvest times (mid-spring and late autumn) the chanting associated with reaping, winnowing, or threshing fills the air. The calls of frogs, ducks, ibis, and cicadas can be heard all year around, and hunting is excellent.

The fertility of the land led in ancient times to the worship of animal gods (see "The Gods of Egypt" on page 85). The fellahin are mainly Mohammedan, although a thread of animism persists in some of the many villages located on the spits of high ground between the fields that survive uninundated during the annual floods. The houses are built of sun-baked mud bricks, and are spartan in furnishing. All have flat roofs, often walled, on which the whole family can sleep in the cool of a summer's night. Outside the houses old women

sit and spin cotton or weave intricate cloth and **carpets**, while naked children play. Men make large pots from river clay to be fired in huge ovens, and exchange tales of the harvest and other gossip.

The delta area, very much a maze of farms and ever shifting river canals, is not a place usually on the tourist itinerary, and travelers are treated initially with suspicion by the fellahin. Once proven friendly, however, rules of hospitality result in investigators being invited to share a hovel for the night, and a feast is held in their honor.

Produce from the delta farms is carried upriver to Cairo on the ubiquitous lateen-rigged feluccas. These small sailing craft carry loads of fruit, vegetables, and grains, along with pottery, bolts of cloth, livestock, and whole families on their way to important festivals.

Scenario Hook: A community of deep ones dwell among the fellahin of the delta. Shunned by most, they are a secretive and closed community. Their houses and villages are crumbling and decayed, and only the most "human" of them make trips to Alexandria for the occasional necessary supplies. They are the sworn enemies of the petesouchi, the crocodile men that dwell in the Fayoum upriver.

British Control in Egypt during the 1920's

Formerly part of the Turkish empire, Egypt became a British protectorate in 1914. During the Great War (World War I) Egyptian troops fought alongside Allied forces in the Sudan. In return for Egypt's cooperation, a number of favors were promised by the British, one of which was self government.

A Promise Broken

At the end of the war the British conveniently forgot many of the promises that had been made to the Egyptians, and returned to governing Egypt as a colonial outpost in Africa. Understandably, the locals were not at all happy with this state of affairs. Chief among the dissidents was Saad Zaghlul Pasha, a minister in the government from 1906–1913, when he was elected to the National Assembly. At the end of the war he began to lobby for Egyptian self-determination, and as a consequence of the militant activities of his followers (street marches, general strikes, and violence against the British) in March 1919 was exiled from Egypt.

RIOTS

Street marches continued in early 1920, with all Europeans advised to stay indoors and armed guards at the doors of all hotels. Throughout 1920 ministers sympathetic to the British were bombed, British officers and troops were assassinated, and there were violent riots in most towns and villages. In May 1921 there were violent riots in Alexandria following the shooting of Egyptians by police in Tanta. Windows and heads were broken, shops looted and unaccompanied Europeans attacked. British troops eventually managed to clear the streets and restore order.

THE EXILE RETURNS

In 1922 Zaghlul was allowed to return to Egypt, but further riots broke out wherever he spoke to crowds. On 23 December 1922 he was once again deported, this time to the Seychelles. More English officers and tourists were killed in November 1922, and political murders averaged two per month throughout 1922.

Self Rule

On 28 February 1922 Lord Allenby, the British High commissioner in Egypt from April 1919 to mid-1925, declared the sovereignty of Egypt, and Sarwat Pasha was made the leader of the government. Prince Fuad of Egypt was declared King. In December 1922 there was a call for a boycott of Englishmen and all items of British manufacture until Zaghlul was permitted to return from exile. This resulted in further street riots, and the leaders of the call were imprisoned. More murders of Englishmen followed.

In January 1923 Sarwat was replaced by Tewfic Pasha Nessim, who was himself replaced in April 1923 by Yehia Pasha Ibrahim. On 19 April 1923 the constitution was published, along with a bill of indemnity for all involved in the uprisings. Zaghlul was free to return, which he did in September. The elections in September 1923 saw Zaghlul Pasha elected Prime Minister, and he then traveled to London to talk to the British parliament. On arriving at Victoria Station he was the target of an unsuccessful assassination attempt, the news of which caused minor street riots in some parts of Cairo. He returned to Egypt in October 1924.

ASSASSINATION

In September 1924 the Egyptian army rioted at the Atbara barracks, with widespread looting and pillaging. On 19 November 1924 the Governor General of the Sudan, Sir Lee Stack, was assassinated by Egyptian nationalists in Cairo, just outside the British Residency near the Garden City. At his funeral, Allenby reprimanded the Egyptian government, and shortly afterwards Zaghlul resigned as Prime Minister. All Egyptian military units were ordered out of the Sudan by the British in retaliation. The new (appointed) Prime Minister was Ahmed Pasha Ziwar.

New elections were held in the spring of 1925, and Zaghlul was re-elected Prime Minister by a substantial majority. Ziwar called for King Fuad to dissolve the par-

liament and to investigate corruption in the election. Ziwar then left for a holiday in Europe.

Lord **Allenby** ended his term in mid-1925 and was replaced by Lord Lloyd in October of that year. By November 1925 there was still no parliament or **true** Prime Minister, although Ziwar was still the acting PM.

CORRUPTION

New elections were held in 1926. Zaghlul announced that he would not accept the leadership, but when his party, the Wafd (Al-Wafd **Al-Misri**, "The Egyptian Delegation"), won by a landslide he rapidly changed his mind. The terrorism **trial** of two Wafd party **members** closely associated with Zaghlul shortly after the elections resulted in both of them being **acquitted**. This caused a general outcry; the British judge resigned from the case, and the King dismissed Zaghlul as Prime Minister, and appointed **Adli Yeghen** in his place.

King **Fuad** visited England in July 1927 and a draft treaty was proposed between Britain and Egypt.

Zaghlul died on 23 August 1927. Yeghen resigned in 1927 and was replaced by **Sarwat Pasha**.

In February 1928 Sarwat was in trouble over a previous promise to support the new Egyptian-British treaty, when he spoke out against it in public. This led to student demonstrations in Cairo and a call for scrapping the treaty. Sarwat resigned in March, and Mustafa **en-Nahas** Pasha became Prime Minister on 16 March. His ministry was dismissed on 24 June, and **Mahmud** Pasha was appointed **Prime** Minister. On 19 July 1928 parliament was **dis**solved by royal decree, and the **parliamentary** regime was formally suspended for three years.

In May 1929 an agreement was reached between Britain and Egypt regarding the water rights of Egypt and Sudan, and **the use** of **Nile** water in irrigation.

POLITICAL TURMOIL AND INVESTIGATORS

Throughout the **1920's** there is on average one foreign national killed per month, and a street march or riot every two months. The marches rarely result in violence but can often be spectacular, with thousands of students and workers **involved**. At night the tops are **knocked** from gas street lights, and the escaping gas lit to create immense gas torches with flames that leap yards into the air.

While investigators will rarely be in danger from this trouble, there is always a chance that one will be in the wrong place at the **wrong** time, and an angry mob is rarely capable of rational thought. Guards at the hotels accompany tourists during times of trouble, and will actively discourage investigators from venturing out during the worst of the violence.

Scenario Hook: Political unrest and cultist activities make a deadly brew. The consequences of one secret agenda after another, layer upon layer, may be far from the kind of horror the investigators expect, but it could well be more deadly and sanity-eroding!

Welcome!

"Then at last we saw Cairo glimmering through the growing dusk; a twinkling constellation which became a blaze as we halted at the great Gare Centrale."

Cost of Living

The cost of living in Cairo depends on the **circles** you move in. For the foreigner, the prices of most everyday **items** are only **10%** to **20%** less than in England or America. For the local, the prices are as much as **80%** less than in England or America. Locals gain a definite advantage in bargaining, and also know where to go to get the best **prices**. They also generally buy different items. **Western (imported)** goods and foods and tourist items are sold at high prices. Locally made everyday items (**pots**, pans, clothes, shoes) and Egyptian food are considerably cheaper than **western** goods. A meal for two in a good hotel **will** cost as much as **20 P.T.**; a **meal** for two **from** a street stall or an Egyptian restaurant will **cost** less than **2 P.T.**

Getting Around

Finding Your Way

Navigating around Cairo is difficult at best, with most instructions taking the form of, "walk along this street until you pass the house of **Ahmed**, turn right three houses after, continue until you see the house of **Hasim**, turn left and head towards the Mosque of **Berkih** and then for three alleys after until you see the orange seller and then ask for further directions" Most alleyways are dead ends, and during riot periods investigators should take great care not to get herded into them.

SAMPLE TRAVEL TIMES

These are all per kilometer. On foot: main roads 15 minutes; side roads and alleys 20 minutes; markets 30 to 45 minutes. By cab (horse or motor): main roads 8 minutes, side roads 12 minutes, markets and **alleys** impassible. By tram or bus: 12 minutes with frequent stops.

Transportation

HORSE CABS

The most common way of **getting around** Cairo is still the horsecab. These have either one or two horses drawing them and **can** be **obtained** at any station or hotel, or hailed in the street. Most are open **cabs**, closed **cabs (landaus)** must be booked ahead of time and **cost** more. A price should be agreed on before **commencing** the trip, and baksheesh (a tip) is only given for long journeys. Most **cabmen** are illiterate and usually rely on the passengers for mute instructions. This **can** be a problem for new visitors.

Prices: 1 to 3 passengers, **3-1/2 P.T.** first km, 1 P.T. per additional **400m**; up to 1 hour 12 P.T.; whole day 85 P.T.

Sample journeys and costs: Opera Square to Citadel 11 P.T. (16 P.T. return), Old Cairo 15 P.T. (25 P.T.), Tombs of Caliphs 13 P.T. (20 P.T.), Pyramids of Giza and Mina House 46 P.T. (60 P.T.).

MOTORING

Motor cabs, or taxis, are rare in the early **1920's**, but by the end of the decade they are beginning to replace the horse cabs. They are unable to enter most of the old parts of Cairo due to the narrow winding streets, and the press of people on most of the roads makes travel slow at the best of times. They can be found outside most hotels and at stations, or may be booked by the day. They are not usually hailed in the street. Drivers are also illiterate and largely unable to navigate around Cairo. Prices: 4 P.T. first km, 1 **P.T.** per additional **333m**. Day hire 3 **£E**.

Motorbuses travel most main roads through the city to the pyramids and can be hailed at any point on their route. They are often dirty.

RAILROAD

Trains run from the Central Railway Station to Alexandria, Port Said, Suez, the Delta and Upper Egypt. Pont **Limon** Station, adjacent to the Central Station, has trains to Shihin el-Qanatir, **Qubba**, Zeitun, **Matariya** (Old Heliopolis) and El-Marg. Bab el-Luk Station, near Abdin Square, has trains to Helwan and Ain es Sira. Prices: vary with season and class, from 1 **£E** 23 P.T. to Alexandria first class, to a few **mill.** for a short trip in third class.

The Electric Express Railway runs from the city center to Heliopolis Oasis or New Heliopolis, a suburb, which has the only airstrip in Cairo.

Welcome Letter

A copy of this letter, personally signed by an assistant to the British High Commissioner, is sent to all foreign tourists upon their arrival in Cairo.

Dear Honoured Guest,

Welcome to Cairo. Cairo is a city of contrasts. A modern metropolis peppered with ancient treasures, Cairo is a city to be experienced and enjoyed.

Modern Cairo is the equal of any city in Europe or America. Its hotels offer all the comforts of home, its restaurants and cafes the flavours of Europe as well as those of Egypt. The Opera House and Theatres play host to the **finest** performers in the world. Modern tramways operate twenty-four hours a day, and reach every point of the city. Its streets are safe to walk, and travellers are welcome everywhere.

The Old City has changed little since the days of The Arabian Nights. **Walking** through its streets, one is transported to the Cairo of **Sinbad** the Sailor. Its bazaars hold treasures from ancient and modern times, and you will find the shop keepers are courteous and keen to please.

Cairo can be an educational experience as well. Its excellent museums and libraries are open to all, and I urge all visitors to take advantage of them during their stay. The oldest university in the world, **Al Azhar** University, a seat of learning since the **10th** century, is now complemented by one of the newest, The American University of Cairo.

I encourage you to take a little extra time, and to visit the nearby pyramids at Giza. These Wonders of the Ancient World should be a compulsory part of any visit to this marvellous metropolis. Should you have a fortnight to spare I **can** recommend the excellent cruise trips up the Nile river to the cities of the Ancient Pharaohs. This is the real Egypt, and should not be overlooked.

Cairo is a city of growth; growth towards a strong and vibrant future firmly built with the traditions of the past. I hope that you enjoy your stay in Cairo, and that you will return again. Should you require my assistance do not hesitate to contact me.

Your servant,

(1920-1925) Lord Allenby

(1925-1929) Lord Lloyd

(1929-1930) Sir P. Loraine

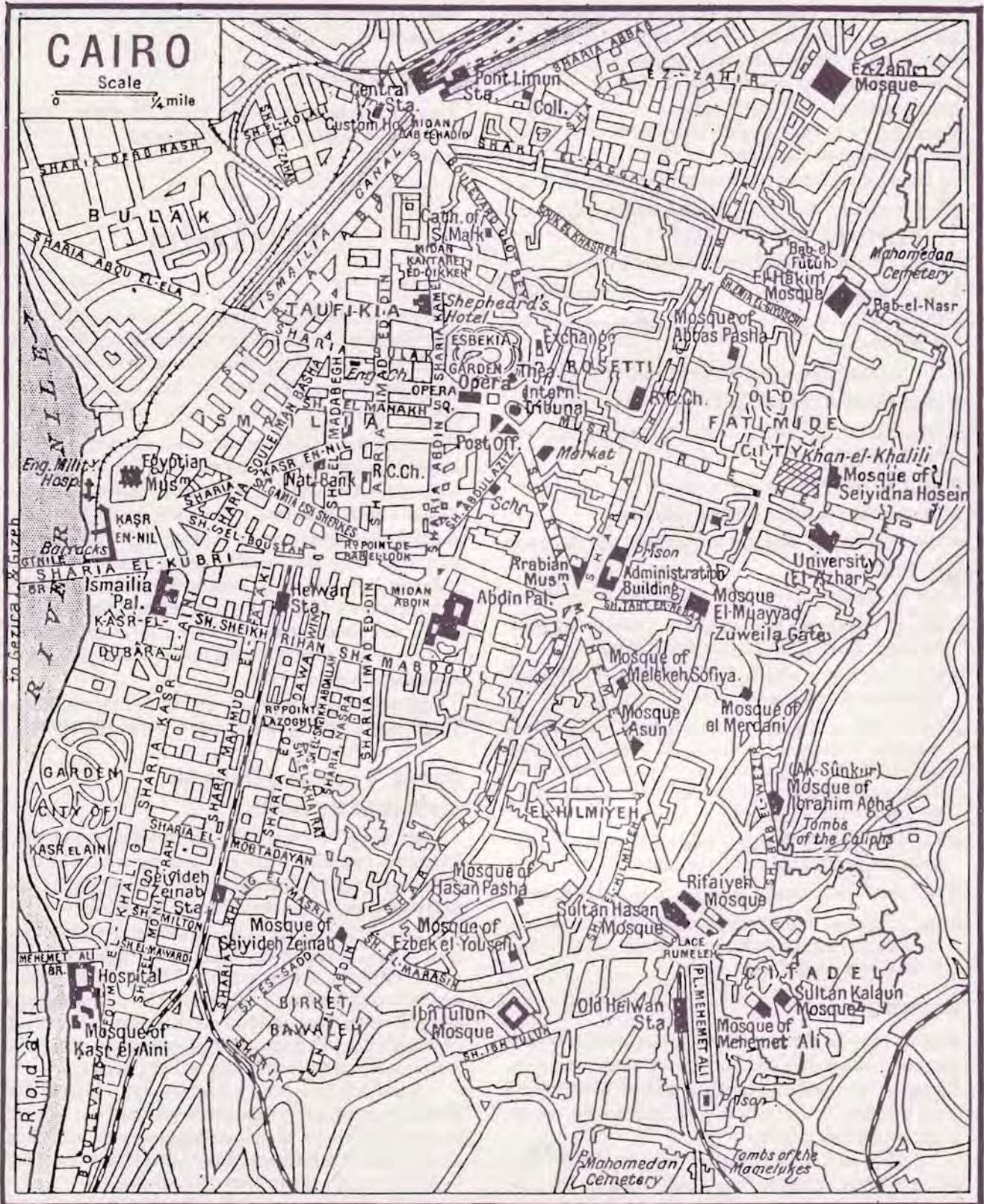

TRAMWAY

There is an extensive tramway system in Cairo, first established in the mid-1800's and completed in 1917. Trams run along most of the **main** streets and to all tourist destinations (except the Tombs of the Caliphs), including to the pyramids. They have separate compartments for women, and female investigators traveling in **the** main compartment may be objects of ridicule by good Mohammedan men. **The** trams run every six to twelve **min-**utes, depending on the route.

Each tram is color coded and numbered as follows:

- No. 1 (White Disk): past the Egyptian Museum and south along the east bank of the Nile
- No. 2 (Green): to the Gezireh Sporting Club
- No. 3 (Red): **Ezbekiya** to Abbassiya via Central Station
- No. 4 (White & Red): circles the central city past the Arab Museum
- No. 5 (Orange): slaughterhouse to **Shamra** Place
- No. 6 (Green & Orange): Embaba via Gezireh to Citadel
- (There is no No. 7 tram. It was incorporated into another route in **the** late 1890's.)
- No. 8 (Blue): west city route
- No. 9 (White & Blue): **Shubra** to Ezbekiya
- No. 10 (Red & White): North Cairo via **El-Zaher** Mosque
- No. 11 (White & Green): Central Station to Citadel
- No. 12 (White & Orange): Central Station, Egyptian Museum, **Kasr** en Nil, Sayeda **Zeneb** Mosque
- No. 13 (Green & White): Citadel, **Ezbekiya** to Technical School (North Cairo)
- No. 14 (Green & Red): **Pyramids** Line. Ezbekiya, **Gezireh**, **Giza**, Zoological Gardens, to Mena House Hotel and pyramids. 1 hour, **cars** run every half hour 6:00 a.m. to 10:00 pm. (Sundays and holidays every quarter hour, extra cars when full moon)
- No. 15 (Green & Orange): Nile circle, east and west **banks**, Museum, Gezireh, Zoological Gardens
- No. 16 (White & Green): Ezbekiya to Technical School
- No. 17 (Yellow & Red): Central Station, Museum, **Ab-**din Palace, American University. Price: 12 mill. first class, 6 mill. second class

WALKING

Walking is by far the best way to get around Cairo after the trams, although it can also be the most dangerous. Streets are crowded and largely unnamed. Most traders speak English, but may choose not to unless some reward is offered for their efforts.

In the **muski**, or market areas, beggars and children crowd around calling for "Baksheesh!" (alms). The professional beggars all appear to be suffering from hideous diseases, and threaten to rub themselves on investigators unless money is thrown at them **from** a distance.

DONKEY

Donkeys **are** no longer **used** by Europeans within Cairo, although they are often employed at the pyramids. They should only be hired **through** a dragoman, and all bargaining should be **left to him**.

RIVER TRAVEL

Steamers run daily from **Cairo** to the Nile Delta. Excursions upriver can be **arranged** at any hotel.

Hotels

*We stopped at **Shepherd's Hotel** reached in a taxi that sped along broad, smartly built-up sheets; and amidst the perfect service of its restaurant, elevators, and generally Anglo-American luxuries the mysterious East and immemorial past seemed very far away. — "Trapped with the Pharaohs"*

The best hotels in Cairo **are** of world standard. Evening dress is compulsory for dinner. Even the second class hotels **are** well fitted **out**, having electric lights, baths, and in-suite toilets. Most hotels **are** usually booked up in the tourist high season (January to March). **Investigators** **are** recommended to wire ahead for rooms on arrival in Alexandria or Port Said, or to book reservations in advance through a travel agent. In summer many of the hotels are closed; those that remain open lower their prices to attract the few visitors around. Rooms used by children and servants **are** usually half price.

All prices quoted below **are** for full board (room, breakfast and evening meals) unless stated otherwise.

First Class Hotels**SHEPHEARD'S HOTEL**

8 **Sharia** Kamil, **between Sharia** Alfi Bey and **Sharia** Dubre. 350 rooms, **apartment** suites available, prices **from** 160 P.T. per room per night. **Some** suites 1 £E to 2 £E per night. **Open** 1 November to 15 May, closed **during** the summer.

The hotel's spacious terrace is the site of nightly **con-**certs; a ball is held every night in the high season. A garden in back **provides** **al** fresco dining, and also has a large raised dance floor in the center. There is a restaurant and grill room, a bar, and post and telegraph offices open 24 hours a day. All major theaters, **most** night clubs, and the **Cairo Opera** **are** within easy walking distance.

Shepherd's hotel is **the** place to stay in Cairo. The starting point for every expedition, **safari**, or tour of note, its corridors bustle with the pith-helmeted rich and idle of **all** nations. It has been said **that** "Alexandria is merely a signal stop on the tourist road to **Shepherd's**."

While the **accommodations** and food are no better than many other hotels in Cairo, it is the place to meet people of influence. Five minutes from the railway station, and the **center** of social life for Cairo's well-to-do, the serious traveler cannot afford not to stay at



Shepherd's. This reputation is well **earned**, but fails to hide the fact that the hotel **backs** on to a block where the desperately poor live crammed together, their livestock tethered on their rooftops, and that the prostitutes' quarter tethers just across **the** road to the west.

A bulletin board in the foyer holds public and private notices of interest to the European community of Cairo. **The** board lists houseboats to let, flats available, notices of meetings at clubs, and when and where forthcoming social functions are to be held.

Doors at the hotel are never locked, although keys are always provided. **All** staff are scrupulously honest, as far as the belongings of guests are concerned. The only thefts occurring during the 1920's are conducted by a small gang of French jewel thieves. A Chubb safe, located in an office behind the hotel desk, is at the disposal of all guests and staff. Advertised as being the most burglar-proof safe in Cairo, it was never robbed during its existence.

At four stories high, with round cupola towers at each corner and a colonnaded entry foyer and portico, Shepherd's is **an** impressive building. From **the** upper floors the whole vista of Cairo can be enjoyed, **the** flat-roofed houses **gleaming** in the midday sun or moonlight. From west-facing rooms, the pyramids lurk on the southwestern horizon, beckoning to the tourist with promises of ancient mysteries and marvels waiting to be uncovered.

The smell of hot dust rises into the air as **the** **parade** of human, motor and beast **traffic** passes in **the** **street** below, and at regular intervals the constant murmur of life is punctuated by the ululations of the muezzins in their minarets calling the faithful to prayer. Stables and garages at the side of the hotel house the cars and donkeys of **expeditions** preparing to set out into the **unknown** deserts,

and huge caravans of people and **goods** assemble in **front** of the hotel when the adventurous prepare to leave.

Special function **rooms** at Shepherd's include the **Isis** Room and the Moorish Hall. These are often booked for private functions, **dances**, or club meetings, and are lavishly furnished in typical Egyptian decor. **The** hotel is redecorated each year during **the** summer, and reopens each winter newly polished and **finer** than the year before.

The original Shepherd's Hotel was built in **1849–1852** on the site of the Palace of **Alfi** Bey (1750's). There were a smaller palace and a temple on this site (dating from 900 A.D.), which were leveled **before** the **newer** palace was built. Bey's palace was Napoleon's **headquarters** during **the** French occupation (**1798–1799**), and later became Muhammed **Ali's** School of **Languages** (1815–1847). When the **first** hotel was built, the **palace** was leveled; the current building sits over the previous ruins. The cellars excavated for the hotel cut through and across the ancient temple and palace cellars, **as** well as **tunnels** excavated by Bey, Napoleon, and Ali. The original hotel, only two stories high, was replaced in the late **1800's** by the current building.

Note: Shepherd's Hotel burns to the ground in 1952 during the revolution that forces the British out of **Egypt**. The modern Shepherd's Hotel stands on an entirely different site.

Scenario Hook: The tunnels have not been explored, and it is not known to whom the ancient temple was dedicated. Napoleon's troops looted the city for valuables, many of which have never been recovered.

The Staff

Doorman: A huge **Montenegrin** man, the **doorman** keeps beggars and unwanted visitors out. There **are** actually several of these men; selected for their size and demeanor, they **all** look nearly identical, dressed in scarlet and white uniforms with curved daggers at their sides. The **Montenegrins** are doormen to the best hotels in Cairo. **If** one of them is found to be untrustworthy he is immediately put to death by the others.

During marches or riots the foyer is full of **armed** British troops.

Barman: Gasparini, an Italian, commands the Long Bar at the rear of the hotel. He is always able to lend a few piastres to those short of change for a **taxi**, and even extends this to a few pounds for a night on the town. His boast is that he is always paid back, and he is an expert at judging the honesty of people he **speaks** to. He appears to be always on duty. First thing in the morning he is standing at



the bar with a cherubic smile on his face, ready with his famous "pick-me-up" called the "Corpse Reviver." The unfortunate overimbiber leans on the **bar** while Gasparini ties a white napkin around his neck, mixes the drink, pours it down his throat, wipes his mouth with the napkin, and then gently escorts him to a nearby lounge chair. Within half an hour the **hangover** gentleman is feeling surprisingly better.

Chief Porters: Hans, Sven and Lars Meyer are the chief porters at Shepherd's. These Swiss brothers take their jobs as Hall Porter, Under Porter and Luggage Porter, respectively, very seriously. Little goes on at Shepherd's that the Meyer brothers don't know about.

Managers: Charles Behler is the manager in the early to mid-1920's. Originally from Switzerland, he rose through the ranks to head waiter in the 1880's before becoming manager and a major shareholder of the hotel in the early 1900's. He turns over running of the hotel to another Swiss national, Freddy Elwert, in the late 1920's.

Elwert cannot tolerate guests who smoke between courses at meals, and employs extra staff to move among the patrons and snuff out any offending cigarettes or cigars. Elwert is also an inveterate practical joker, and cannot resist pulling small jokes on visitors considered too **stuffy** for their own good.

Staff are eager to assist investigators in any legal, and most illegal, activities not involving other hotel guests. The latter can be arranged for a fee of approximately one week's accommodation in foreign currency.

The Clientele

Travelers staying at Shepherd's in the 1920's include Lord **Carnarvon**, Howard Carter, Robert Graves, Winston Churchill, Dr. Julian **Huxley**, T. E. Lawrence, members of many European and British royal families, and ex-King Ferdinand of Bulgaria and his niece (frequent guests). A number of Turkish princes are also regulars; **Prince** Fuad (later King Fuad) often calls at the hotel to visit them.

The discoveries of many rare and unusual artifacts were first announced to patrons on the balcony of Shepherd's Hotel, including that of **Tutankhamun's** tomb by a very excited Howard Carter in 1922. He waited for Lord **Carnarvon** to join him in Egypt, so that they could both be present when **the** tomb was opened.

Parties: Balls **are** held every night of the season, some more opulent than others. The greatest held during the twenties is the "Faerie **Cingalaise**", held on 17 March 1928, the night of the **Allenby** Cup horse race, which was won by a horse bred by the hotelier, Charles Behler. This is a ball attended by all the best people in Cairo, with others traveling from afar to attend. Among the guests **are** the Maharaja of **Mysore**, the Maharaja of **Kapurthala** and the wealthy industrialist About Pasha, seventh richest man in the world.

The main restaurant is transformed for the event into a tropical rainforest of giant palm trees and vines. Demon masks lit from behind are hidden among the fronds; lifelike stuffed animals (lions, tigers, baboons and gazelles) appear to move as fans waft the vegetation to and fro. Brilliant birds perch in the trees, and snakes coil around the candles on each table. Native huts flank the central archway to the ballroom, which resembles a temple to Kali. A giant statue of the Indian goddess takes a place of pride, with glowing lights shining from her mouth and eyes.

Costumes **are** distributed to all the guests as they enter: headdresses for the ladies, turbans for the men, silver snake bracelets, fans of feathers shaped like butterflies, and **drums** on all the tables.

A ball two weeks later has the theme of **faery** tales, and the ballroom is converted into a wonderland of Red Riding Hood and Puss-in-Boots' delight. The guests include Prince Stolberg Wernigerode, Prince Stolberg Fossila, the Comtesse de **Salverte**, Count Nostitz, and the officers and ladies of the 15/17 Hussars.

Costume dances are also very popular. Themes include "**Fête des Corsairs**" (pirates), "**Sous les Ailes**" (the ballroom is Heaven, a second room is Hades), and "A Night at the Trianon" (Marie Antoinette's court). Hundreds of pounds **are** spent on some costumes. All tables **are** always full, and the hotel responds with thematic gifts, or favors, to all attendees. The first ball of the winter season is always held by Shepherd's. The dance bands pride themselves on being the first in Cairo to play all the latest tunes; as one band member says, "**Last** year's **dance** tune is like last year's flirtation—best forgotten." Bands playing regularly include the Lotus Band and Joe **Rainer's** Hill Billies.

SEMIRAMIS HOTEL

On the east bank of the Nile, just south of the **Kasr el-Nil** Bridge. 200 rooms, central heating; prices from 190 P.T. per room per night. Bar, post office, garden, restaurant, roof terrace grill. Open 1 December to April 15. Owned and operated by the same company as **Shepherd's**

This is a high class hotel, with views overlooking the Nile from half the rooms. Guests can watch the passing parade of river traffic and enjoy cooling breezes at night. This hotel is only one block from the American University and the Egyptian Museum. Cabs are required to travel to theaters, nightclubs, or the opera, but the view and the quality of food and service easily overcome this. It is rumored during the **1920's** that the royal suites on the top floor **are** occupied by the survivors of the Russian royal family, and armed guards at all entrances to this floor refuse to allow any strangers to pass.

Scenario Hook: Lady Bramwell has traveled to Cairo to find her son Cuthbert (Berty), missing since the start of the decade. An athletic and energetic young man and heir to the Bramwell millions, he showed great interest in the treasures of the Valley of the Kings, and was a keen archaeologist. He has not been seen or heard of since October 1920, and the private investigators she has hired have had no success. She returns to Egypt each season in the hope of finding some trace of him. She always stays at the Semiramis.

Berty has become a member of the Children of the Sphinx and has no intention of returning with his mother, preferring the power he experiences while performing rituals to the lure of a rich but boring lifestyle. He can be traced to the Egyptian Museum laboratories at Thebes but no further, unless the investigators speak to Batty Gunn at the Museum. Batty saw him near the grotto in the Zoological Gardens a few weeks ago. Batty called out to him, but Berty turned and ran.

Good Quality Hotels

CONTINENTAL SAVOY

2 Sharia **Kamel** in the Opera Square, between Sharia **Bulak** and Sharia **Maghrabi**. 400 rooms, suites of **apartments**; price 140 P.T. per room per night, **cheaper from** May to November.

A good hotel, frequented by **German** and European tourists and by British middle class.

VICTORIA & NEW KHEDIVAL

2 Sharia **Nubar** Pasha. 120 rooms; prices from 100 P.T. per room per night. Proprietor J. Vocles. Open all year around.

A good hotel, popular with wealthy visitors from other African and Oriental **countries**. The food here is excellent, although largely local delicacies. Away from the general rush of tourists, this hotel is frequented also by many involved in excavating for, or connected with, the Antiquities

Department. Several government ministers have permanent accommodations here.

"Hôtels Garnis"

These establishments usually provide bed and breakfast only. Although evening meals can be arranged for entirely negotiable prices the traveler is advised to eat out—it's easier on the stomach.

MODERNE

Sharia **Imad el-Din**, corner of Sharia **el-Malika Nazli**. 55 rooms; from 30 P.T., extra 7 P.T. to 10 P.T. for breakfast. One block from the main railway station.

HÔTEL DU NORD

Sharia **Imad el-Din**, near the main railway station. 76 rooms; from 20 P.T.

Just across the road from the station, this establishment hires very large and loud touts; it is very likely that **arriving** travelers will notice them.

HÔTEL DE PARIS

10 Sharia el-Maghrabi, Passage **Groppi** (down alleyway). 30 rooms, 38 P.T. to 54 P.T., breakfast extra 8 P.T. to 12 P.T. Near **Groppi's** (a very popular place to be seen) and the Continental Savoy Hotel.

Guest Houses

These establishments provide a minimum of services, with no in-suite bathrooms or toilets. **Breakfast** and evening meals can be arranged with the proprietors for negotiable fees, but **are** of widely varying quality. Guests staying for long periods of time become part of the family, and the proprietors **will** look after them as if they were their own sons and daughters. This can be extremely useful if investigators get into trouble. Prices vary considerably, but are usually in the range of 60 P.T. to 100 P.T. per **night**, or 12 **£E** to 15 **£E** per month.

DRUMMOND HOUSE

6 Midan Suliman Pasha. **Proprietress** Mme. Frizell. **On** Suli-man Square one block from the Egyptian Museum.

Madame Frizell is a middle-aged French-Egyptian Jewish woman, with two very attractive and marriageable daughters.

BRITANNIA

13 Sharia el-Maghrabi. Proprietress Mme. E. **Rosenfeld**. In the heart of town, near **all** the best places and nightspots.

Madame Rosenfeld is a typical Jewish mama. Guests are not permitted to leave the house hungry.

MORISSON

9 Sharia Nahassin, 3rd floor. Proprietor M. **Morisson**. In the bazaar district.

Monsieur **Morrison** is a collector of rare and unusual books on Egyptian history; he keeps a library in the cellar. This may prove invaluable to investigators. In the heart of the bazaar district, an easy walk to the Al-Azhar University, this is a noisy but exciting place to stay. The passing flow of shoppers begins an hour before dawn and ends just after midnight; sleeping may prove difficult.

Budget Accommodations

Inexpensive accommodations can be found at the Y.M.C.A. (for men only) or the Y.W.C.A (women only). Both of these are in the **Ezbekiya**, near Opera Square. Accommodation is in open dormitories, and costs **10 P.T.** per night. Meals are not included.

Extra cheap lodgings may be found at the Catholic Sisters of St. Charles **Borromeo**, 8 **Sharia el-Quasid** (Kasid), at a cost of 6 P.T. per night. They will aid wounded travelers, but frown upon any occult or dubious activities.

Heliopolis Oasis

One of the popular resorts just outside Cairo, this is fast becoming the favorite out-of-town haunt of the young and wealthy. The hotels here are full of bright young things doing what bright young things do: staying up all night and crashing all day.

HEUOPOLIS PALACE

500 rooms; prices from 140 P.T. per room per night. A first-class hotel with restaurant, gardens, etc. At the end of the electric railway. Open December to April.

HELIOPOLIS HOUSE

80 rooms; prices from 80 P.T. to 100 P.T. An excellent hotel, with a large terrace on which concerts are held each night (formal dress compulsory), a restaurant, and bar.

Near the Pyramids

MENA HOUSE HOTEL

200 rooms; prices from **130 P.T.** per room per night. All facilities are available, including post office, gardens, baths and swimming pool, grass golf course (a rarity in the desert), and tennis courts. Open all year round. At the terminus of the No. 14 tram to the pyramids from Cairo. Hotel motorbus from the station costs **15 P.T.** Run by the same owners as **Shepherd's**.

This hotel attracts a wide variety of wealthy travelers, historians, antiquarians, and crackpots due to its proximity to the pyramids, which dominate the horizon to the southwest. It is also considered to be one of the best curative resorts, the dry desert air and heat being especially good for chest complaints. The wealthy sick and infirm from all over Europe spend the winter here, and there is no shortage of fashionably gaunt beautiful young women escorted by doting elderly maiden aunts.

Camels and donkeys can be hired from here for tours into the desert and to the pyramids, and the forecourt outside the hotel is packed every morning with a variety of dragomans touting for business.

On moonlit nights, tours of the pyramids and Sphinx are especially popular, and at solstices and equinoxes occultist recreationalist groups meet here before reenacting "ancient" ceremonies in front of the Sphinx.



The Sights of the City

"We had struck east past the Ezbekiyeh Gardens along the Mouski in quest of the native quarter ..."

The Ezbekiya

Dining in Cairo

The **Ezbekiya**, or New Quarter, of Cairo is the hub of European life. The hotel and entertainment district here are the necessities of life for the traveler abroad.

Cairo in the **1920's** is the equal of any European city in the quality of its restaurants, cafes, and theaters. Most of these are to be found in the **Ezbekiya**. There are many in Cairo who simply do not exist in public until after dark, and spend the night moving from one fine restaurant to another, finishing up at a dance until dawn. The young and frivolous wear the latest Paris and London fashions, drink the most expensive cocktails, and take opium and hashish. There is no shortage of companions for investigators of either sex, many being introduced to the investigator by their older relatives.

HOTEL RESTAURANTS

These are the most common places to dine while in Cairo. The quality of the food is directly related to the quality of the hotel. In many cases the cost of accommodation includes the evening meal, although wines, cocktails and after dinner drinks are extra. Hotel restaurants are good places to meet patrons of the hotel. Dining alone or in small groups may result in sharing a table with other guests if so inclined; the resulting conversation may lead investigators into an adventure.

All of the best hotels hold dinner dances and concerts during the season, many featuring internationally renowned artists. These evening dances are frequented by gigolos and expensive prostitutes. Dress is formal, and dances begin at dusk and continue well into the early morning.

GROPPI'S

This is the place to be seen in the 1920's in Cairo. Groppi's is a luxurious catering establishment, founded in Cairo around the turn of the century by an Alexandrian Swiss family. Originally housed in a single location (Groppi's) at 11 Sharia **Manakh**, a second establishment opens in 1924, on Suliman Pasha Square (**Midan Suliman**) and is named Groppi's Comer House.

In addition to fine food, both shops also sell fine china and glassware (**Sèvres, Meissen, Lalique**) and silverware. Their primary stock in trade during the day are afternoon teas, aperitifs, **confectionary**, patisserie and **delicatessen**-style food. At night they serve fine cuisine in the French and British tradition. At the rear of the new restaurant, a garden surrounds a rotunda with a stained glass ceiling. Concerts are held here three times a week during the season, with dinner and supper dances on the other four nights. Dances and concerts are also held at the original restaurant until late 1924, when they are replaced by a string quartet playing nightly.

OTHER RESTAURANTS

Celestino: 4 Sharia Alfi Bey, behind Shephard's Hotel. Excellent European food and wine, dancing nightly.

Flasch: above Celestino. A more lively dining and party experience, popular with the under thirties. **Flasch** has private rooms available for meetings.

Ritz: 14 Sharia Tawfiq. An expensive restaurant, with the cost to dine defined by the place's reputation rather than its food.

El-Hati: Sharia Alfi Bey. The best "native" restaurant in Cairo, serving local delicacies in a way that European palates can tolerate. Silver service and modern decor clash with traditional Arab food, which is best eaten with the fingers while seated on the floor.

Luna Park, **Parisiana**, **Suisse**, and **Brasserie du Nil**: all also in Sharia Alfi Bey.

BARS AND EUROPEAN CAFES

(women not welcome)

New Bar, **Mahroussa Bar**, and **Cafe Khedivial**: all in Opera Square. Fine wines, beers and spirits mingle with thick cigar and cigarette smoke. Food available in private booths, mainly European style.

Opera Bar: Opera Square. Drinks only. Popular with the British military.

Many other cafes in the European style crowd the streets in the Ezbekiya district. None welcome women.

PRIVATE HOUSES, EGYPTIAN RESTAURANTS

When befriended by an Egyptian, an invitation to a meal follows soon after. This will usually be for men only; women dine with the wives of the host if they are invited at all, although the meal is identical in content and style. Whether the meal is to be eaten at his home or at a native restaurant, it is advisable to arrive with an empty stomach and eat sparingly of the **first** courses, unless you wish to bloat before the third and fourth courses, not to mention the fifth to ninth courses.

At the start of the meal Mohammedan grace is said by the host: *Bi-smi-llahi-r-rahman i-r-raheem* ("In the name of God the compassionate and the merciful"). The host first tastes the dish, and then the guests may eat. Food is eaten by breaking off a piece of the thin flat bread served with the meal and dipping it into the dish to hook a piece of meat. All food is eaten with the **fingers** of the right hand; it is considered disgusting to eat with the left, that being traditionally used instead of toilet paper.

The typical meal consists of alternating sweet and savory dishes. If you slow down and stop eating, the host will pick out the tastiest morsels of food and pass them to you; it is extremely impolite to refuse these. At the end of the meal the host declares *El-hamdu li-llah* ("Praise be to God"), and servants come with copper basins of water and towels for the guests to wash their hands. It is a great insult to leave before the meal is finished.

Entertainment is usually provided with the meal. Musicians (*alatiya*) are present at every Egyptian restaurant or private celebration. Playing the *zembr* (oboe), *zumarra* (double flute), *tabl baladi* (drum), *riqq* (tambourine with bells) and *darabukka* (funnel-shaped drum), they accompany the meal and speeches, as well as the singer who often has composed a special ballad in honor of the host or occasion. Female dancers (*ghawazia*, or belly dancers) are found in all Egyptian restaurants, although they are considered to be inferior to the ones who were there even twenty years ago. The dancer's main aim is to titillate and flatter the host, while making every other man feel that she is dancing for him alone. Waving her body in a sinuous and seductive style to the music, the dancer begins slowly at first and gradually builds to a frenetic crescendo, complementing the music by stamping, twirling and writhing in time, eventually collapsing to the ground at the feet of the host as the last note sounds.

Female singers (*awalim*) perform only to other women in the harems of the wealthy. Their songs tell of the power that women have over men in the use of their bodies and the control of their lusts; men would be **horrified** if they ever heard them.

Other entertainers include storytellers and jugglers (*huwa*), as well as snake charmers (*rifaiya*) who seem to defy death in the way they handle and **charm** deadly cobras.

Mohareb Todrus

A Turkish Mohammedan with three wives and somewhere around **fifteen** children ("I lost count years ago!"), Mohareb is a jovial and helpful host. He is also one of the most useful contacts the investigators could make in Cairo. He is aware of the darker underside to the city and



can put them in contact with a small enclave of his friends, the Sons of the **Mamluks**. They are all descendants of the mamluk rulers of Cairo, dedicated to fighting Mythos activities and controlling Mythos worshippers. Mohareb is well known in all of the markets; shopping with him, or his assistant and son Alim, results in **substantial** discounts and better quality goods. Once he gets to **know** and trust the investigators they are welcome in his restaurant and home at any time of day or night: "You are all part of my family now."

MOHAREB TODRUS, Manager and Host of The Prophet's Grace, an Egyptian restaurant in the Ezbekiya, age 46

STR 16 CON 12 SIZ 17 INT 14 POW 11
DEX 12 APP 12 EDU 10 SAN 45 HP 15

Damage Bonus: +1d6

Weapons: Kitchen Knife 70%, damage 1d6 + 1d6
Rifle 45%, damage 2d6 + 4

Skills: Bargain 90%, Cook 85%, Cthulhu Mythos 10%, Evaluate 85%, Occult 50%; Languages: Arabic 60%, English 43%

Entertainment

CINEMAS

There are many new cinemas in Cairo, most in the new district of the **Ezbekiya**. All show a good variety of European films and newsreels. Admission prices of 1 P.T.–3 P.T. ensure that the cinemas are usually **patronized** by Europeans.

THEATER AND OPERA

Cairo Opera House: Opera Square. Hosts a good French or Italian opera company **during the second half** of each winter season. **Tickets** may cost as much as 5 £E for a private box, or 20 P.T. for the stalls. Evening dress is compulsory. Closed boxes are available for Mohammedan women.

Kursaal Theatre: Sharia Emad el-Din. A variety theater hosting French and Italian companies. Popular with **middle-aged** Europeans.

Pelote Basque: Opera Square. A music hall and casino, frequented by the wealthy after the opera or theater. Heavy gambling takes place in the private **rooms** upstairs. Private rooms are also available for **entertaining** ladies or gentlemen of the night. Discretion is assured.

Bands: The British Military Band performs every weekend and on Mondays, Wednesdays and Fridays in the evening in the Ezbekiya gardens.

PRIVATE CLUBS

There are a number of private clubs in Cairo in the 1920's. Admission is usually by introduction of a member, but most good hotels **can arrange** temporary memberships for clients of good character. Most are men-only clubs; a few allow

women to lunch when accompanied by a member, but they **are** not permitted anywhere else in the building and must leave the premises after the meal. Some clubs have extensive libraries and antiquities collections, and **all** will aid a member at **all** costs, even when doing so may go against local law.

Muhammed Ali Club: Sharia **Suliman** Pasha. Very exclusive; frequented by the Egyptian royal family (until late 1924) and the director of the museum. Decorated with English and French antiques, it is the finest and most expensive club to dine in, with meals frequently costing 20 £E–100 £E per person. Service is impeccable, and it is a place to meet those who really run the country, not the ministers who think they do.

Turf Club: 12 Sharia **Machraby**. An exclusive club, popular with the British in Egypt. A casino on the second floor is **busy** most nights.

Royal Automobile Club: Sharia **Kasr** el-Nil. Founded in 1924, it becomes the place to be seen soon after. The royal family frequent it from early 1925 onward. Poker games in private rooms upstairs are held for thousands of **Egyptian** pounds per hand.

Gezireh Sporing Club: Gezireh Island. **The** ultimate sporting club—**equipped** with a golf course, race course, swimming pools, squash and tennis courts, polo fields, cricket pitches, and football fields—this is the place for those interested in sports. Horse racing is held here twice weekly. A world class restaurant and nightly dances are additional attractions; most members keep a **room** in **the** palatial club house during the season. All of **the** best people in Cairo are members, and proposed members are thoroughly investigated before membership is granted. Temporary memberships **are** available through the British and American embassies. An excellent place to **meet** people of power and influence, recruiters for the secret societies in Cairo check **the** talent here regularly. Membership is men only, but wives and girlfriends of members share all privileges.

SCIENTIFIC SOCIETIES

An alternative to the private clubs—and just as exclusive and tightly knit—these societies are comprised both of professionals working in the area and keen but rich amateurs. Membership is available by invitation only, but those who have made sizeable donations to the societies are automatically invited to join.

Société Royale de Géographie d'Égypte: Sharia **Kasr** el-Aini. Founded in 1875 by the explorer Georg **Schweinfurth**. An excellent library and reading room is open only to members and contains many rare books of extreme interest to investigators. A plant collection and a small ethnographic collection are open to the public daily from 9:00 a.m.–12:00 noon. **Battiscombe Gunn** (Museum Curator) is a member, and is happy to nominate worthy investigators for membership. The president is Dr. W. F. Hume; the secretary is H. Munier.

Institut d'Égypte: Sharia Sheikh **Rihan**. Founded in 1859 at Alexandria, it has an extensive library of **books** on Egyptian history, o v a **27,000** volumes, which is open only to members or **bona fide** researchers. The president is M. **Mosseri**.

Institut Français d'Archéologie Orientale: Opposite **the** Egyptian **Museum** (adjoining museum by a network of cellar tunnels). A library of over **20,000** volumes on archaeology in Egypt and the Orient is open only to **members**. The librarian is St. Paul **Girard**; the director is Pierre Jouget. The Museum director and all **the** curators at the Museum are members.

Medieval Cairo

... a story-book and a dream—labyrinths of narrow alleys redolent of aromatic secrets; Arabesque balconies and oriels nearly meeting above the cobble streets; maelstroms of Oriental traffic with strange cries, cracking whips, rattling carts, jingling money, and braying donkeys; kaleidoscopes of polychrome robes, veils, turbans



and tarbushes; water-carriers and dervishes, dogs and cats, soothsayers and barbers; and over all the whining of blind beggars crouched in alcoves, and the sonorous chanting of muezzins from minarets limned delicately against a sky of deep, unchanging blue. — "Trapped with the Pharaohs"

Traveling east down the Sharia **Muski** from the **Ezbekiya**, the investigator enters the part of Cairo built during **the** Middle Ages. Extending from the Avenue Reine **Nazli** (Avenue Abbas) in the north to the Square of **Muhammed Ali** in the south, and from the **Sharia Khalig el-Masri** to the Wall of **Saladin** in the east, the medieval section of Cairo is a place of markets and shops at street level, and cramped housing tenements above.

Like most European medieval cities, the streets **are** narrow and winding with the occasional wider straight thoroughfare running through the quarter. Overhanging second stories shadow part of the street at all times of the day, and waste water is still thrown from windows on upper floors into the street in the poorer sections. Unlike European cities, the roofs of the buildings **are flat**, and on hot summer nights the occupants of the buildings seek refuge from the heat of the day by sleeping on the rooftops. Upper story windows **are** covered by intricately carved wooden lattices, designed so that the women of the Arab harems still kept in this quarter cannot see down to the street below, and that those in the street are unable to see them. Traders come to stand below the windows, and baskets are lowered to allow the women to inspect the

goods for sale. If they are suitable an appropriate sum of money is lowered in the basket in the place of the goods purchased. What the trader considers appropriate is not always what the purchaser wishes to pay, and loud disagreements often result.

This is the true heart of Cairo, the section of the city where the traveler can experience all that it has to offer. Here are the bazaars and the craftsmen, the spice merchants and the animal sellers. Here there is a mosque on almost every corner and the call of the beggar is punctuated only by the call of the muezzin that summons the faithful to prayer five times a day. Home to the Al-Azhar University, said to be the oldest in the world, this is also a quarter of learning, both secular and Mohammedan. Storytellers ply their trade on most streets, surrounded by children and adults alike. They recite the ancient tales of heroes and djinn, of prophets and martyrs, of princesses and caliphs, and all for a sparse handful of milliemes. Water sellers move among the crowds carrying overflowing water jugs; some merely ask the traveler to drink in favor of the rich merchant that has paid for them to pass out the water in his hope of gaining favor with the Almighty, while others charge whatever they think the thirsty can pay.

Most of the streets in this quarter are too narrow for carriages or vehicles. The traffic is largely pedestrian, with the occasional donkey or mule carrying impossibly large loads pushing through the crowds. Shops spill out into the street, the wares for sale often occupying more space in the street than is possible inside the tiny cubicle that has been run by the vendor's family for ten generations or more. Friends of the stall keeper are invited to sit on cushions or stools alongside the shops; a boy is sent running to a nearby cafe to bring back thick strong coffee, and the nargeeleh (or hookah) is lit and passed around.

Women in the streets are usually covered from head to toe, their faces invisible behind opaque veils. The wealthy are accompanied by large bodyguards; the poor travel in groups for protection from infidels. Unescorted and unveiled women in the street are often spat upon by the faithful; in the company of men, unveiled women may hear themselves called "whore."

Beggars and urchins ply their trade in most streets; small children make foot travel difficult by flocking around foreigners that are foolish enough to give money to anyone. Investigators may feel small hands searching in pockets, and any loose objects disappear into the throng of giggling faces. Serious robbery and assault is rare but not unknown, and investigators are most likely to be attacked during periods of civil disturbance in the early 1920's.

Smells

The tenible fear of smells causes many tourists to recoil in horror, thereby missing much of the true experience of Cairo. Many foreigners travel with a Kodak in one hand and a handkerchief in the other.

Cairo would lose much of its charm if not for the smells from the bazaars and the marketplaces. The aromas of moka and ma'assil waft from the coffee stalls. The spice bazaar is evocative of warm tropical islands and

perfumed nights. The fruit stalls are merely piles of gold and russet without the mouthwatering aromas of peaches and grapes. The smell of the tanning agents enhances the colors of the hides in the leather-workers' bazaar. The smells of the beggars are necessary to remind the visitor that this is a real place, and not merely a movie of the Arabian Nights.

The Muski

Starting at the square of Ataba el-Khadra, the Sharia Muski changes names several times before reaching Saladin's Wall. Built in the early 1800's, this street is an amalgam of earlier, less direct streets, and although the official maps list its names as Sharia Muski and Sharia Sikka el-Gedida, the furthest parts are also known as the Sharia esh Shanawani and Sharia ed Darassa. The use by locals of the old names can be very confusing for travelers. The total length of the street is one mile, but it takes over an hour to travel it from one end to the other at the best of times.

The old city of the Fatimids, Medieval Cairo is entered when the Sharia Khalig el-Masri (once the El-Khalig Canal) is crossed. The original walls of the city, erected in 1074, are still seen at the gates of Bab el-Futuh, Bab en Nasr in the north and the Bab Zuweila in the south.

To the north of the Sharia Sikka el-Gedida is the Jewish quarter, called the "Ghetto" in the 1920's. Numerous synagogues replace mosques in this section of the city.

Turning north into the Sharia Nahassin (Sharia el-Kurdagiya at this point) and then turning east into the first cross street (Sharia el-Qumsanwiya) leads the investigator into the covered bazaar of Khan el-Khalili.

Bazaar of Khan El-Khalili

Founded in 1400 by Gharkas el-Khalili, master of the horse to Sultan Barquq, this bazaar is a maze of main streets and numberless cross-lanes and alleyways. Most of the streets forming the bazaar are covered to protect shoppers and stall holders alike from the sun, and trading continues from dawn to well past dusk.

This is the first stop of the tourist to Cairo, and the shops on the Ezbekiya side of the market reflect this. Its stalls are cluttered with gaudy tourist goods, imitation papyrus scrolls, replica pyramids, and postcards by the thousands. During festivals it is lit by hundreds of lamps in and around the shops. At any time, the eye is caught by bright colors: gold-plated charm bracelets, and copper goods imported from India or Greece but sold as local product. Most antiquities sold in these shops are fakes, the closest they have been to the Valley of the Kings is the postcard in the next stall along. Prices paid here for fakes can often be higher than those paid for the real items elsewhere.

Everything that the tourist desires can be found along the main streets, in shops run by Greek, Armenian, and Jewish merchants. Carpets, beaten copper, amber, ivory, silks, jewels of rough gold and silver, and the essence of roses and other flowers vie for attention with the aromas of sweets, cakes, and fried meats. Stalls selling typical

Arabic clothing **are** bedecked with colorful leather shoes, long **cotton** shirts, and the ubiquitous red **tarbouch** (or **fez**). This felt hat of Turkish origin is becoming more popular with the Egyptians dealing with **westerners** and is fast replacing the turban, much to the dismay of older traditional Arabs.

Once the investigator gets off the main streets and into the covered bazaar proper, past the **first** few turns a wholly different vista appears. Here are the quality import shops, the vendors of European goods to the locals and the better quality merchants of each type. Like many other medieval markets, the bazaars of Cairo are divided into distinct sections by trade.

SHOEMAKERS' BAZAAR

The **first** street to the north after entering the market holds the bazaar of the shoemakers. The pungent aromas of leather dyes fill the air, and leather hides and shoes in all possible colors cover the stalls and spill out into the street. Red shoes (**markub**) are favored by the local Arabs, but my color is fair game when **attracting** tourists to buy.

CARPET BAZAAR

Opposite the shoemakers is the carpet bazaar. Intricately decorated and woven designs in reds and earthy tones catch the eye of passersby, and their arms are also caught by the hands of the carpet merchants pulling them into their stalls to inspect the finest silk and wool carpets the Orient has to offer. All claim to be selling carpets of great antiquity and value. "carpets from the days of the Arabian Nights that have belonged to my **family** for hundreds of years." Most are selling carpets made last week which have been professionally scuffed and worn by stiff wire brushes to simulate **the** wear from countless feet over the decades.

Many of the carpets made from Damascene **silks**, especially those made from the most vivid colors, are manufactured in Lyons (France) or **Krefeld** (Germany). Bargaining skills **are** essential, as is a knowledge of quality if the purchaser is not to be fleeced.

COPPERSMITH STREET

Turning right when leaving the carpet bazaar leads through the coppersmith, or brass, bazaar (**Sharia al-Muizz**). A gateway decorated with stalactites leads into the **Sikka** el-Qabawa. Here the sound of hammers against metal can be heard long before the first stalls are seen. Boys of seven and eight sit cross-legged at anvils beating copper sheeting into bowls, platters and jugs. Older boys decorate the objects with intricate stamped and carved designs. The stall holders cry above the din of the **hammer-**

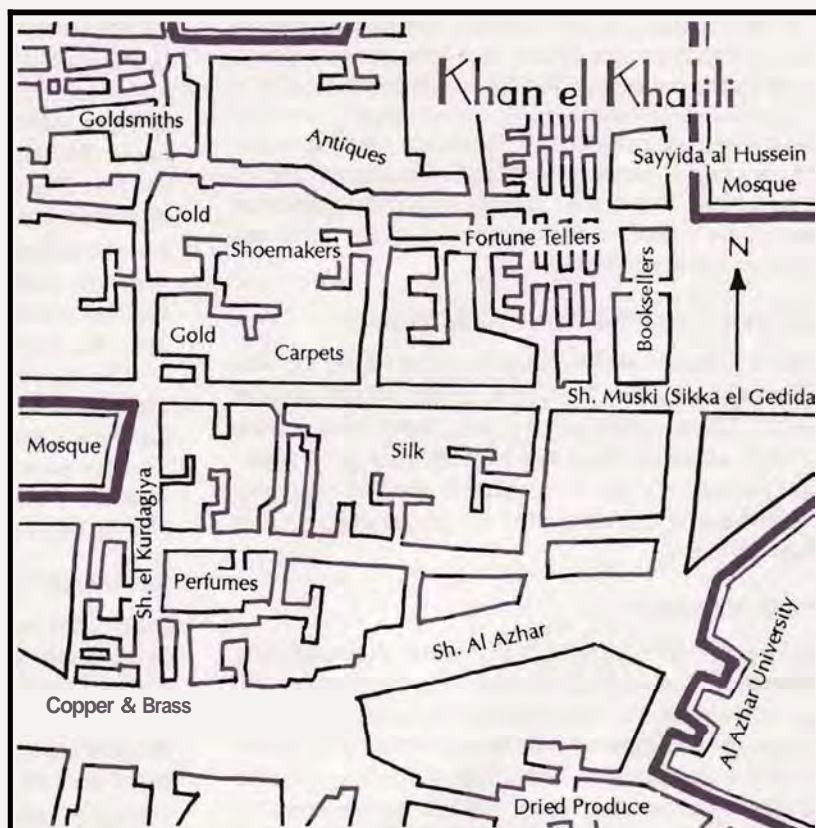

ing for passing shoppers to inspect their wares, "... each the **finest** in the land-i-i any land, have any seen finer?"

GOLDSMITHS' BAZAAR

On each **main** street surrounding the coppersmiths' bazaar, the stalls are filled with gold and silver instead of the cheaper metals. Fine filigree work and delicate beaten silver is on display beside massive gold bracelets and gold rings set with brilliant gems. Hired **guards** stand outside most stalls, and undercover guards mingle with the crowds. The stall holders, mainly Greeks and Arabs, drive very hard bargains.

BAZAAR OF M E BOOKSELLERS

At the eastern end of the Khan **el-Khalili** is the bazaar of the booksellers. These shops are mainly run by scholars, and each shop reflects the interests and specialties of its owner. Most shops stock **mainly** Mohammedan texts and manuscripts; a few stock rarer treasures.

Prices are entirely set by bargaining, and no distinction is made between new and second-hand books. **A book** is considered new if it is less than ten years old, regardless of how many have owned or read it. Most books are piled haphazardly without any sorting, but **the** shop owners know exactly where every tome in **the** shop is to be **found**; it may just take them a little time to locate some of them. They keep full lists of **all items** in stock in the **form** of catalogs many **yards** long, and will happily spend frustrating **minutes** pacing around the shops dragging the catalog behind them. The time to **find** an item in stock can be reduced markedly if a higher **price** is offered for the book in question.

Books published locally consist of folded stacks of loose sheets. It is up to the purchaser to have them bound, although the bookseller can arrange this for an additional fee. Red is the favorite color for bookbindings, which usually consist of leather, **sheepskin** or cardboard. Extremely valuable or rare books are kept in ornately tooled and embroidered cases of red **sheepskin**. Tomes with magical or occult **significance** usually have protective sigils engraved on the cases and covers, and on every page as well.

BAZAAR OF CHRISTIAN MERCHANTS

To the southwest of the Mosque of Bars Bey, the Suq el-Hamzawi contains the bazaar of the Syrians and the Copts. Cloth, porcelain pottery, and drugs of all kinds are sold here, although drugs can be found for a price at any of the bazaars. The prices charged for goods **are** the same as elsewhere, and investigators are just as likely to lose money on a deal.

SPICE MARKET

The Suq al-Attarin, to the left of the Suq el-Hamzawi, is a covered market dealing exclusively in the essences and oils of the Orient. The air is redolent with perfume, and in midsummer investigators may be overcome by the intensity of the aromatic fog. Perfumes of Arabia—genuine and fake—wax candles, drugs, and oils are the items for sale here. All unguents required to duplicate ancient mummification rituals can be found as well, at a price. Those who attempt to bargain down prices on items required for rituals will be given goods that will not work.

SILK BAZAAR

Back towards the Khan el-Khalili is the bazaar of the silk merchants. Here banners of multicolored silk waft in the breezes channeled by the three-story buildings that surround the market. Colored scarves and shirts gleam like jewels in the sunlight, and the silk caresses the **skin** like a lover. Customers are encouraged to try on goods. The stall holders are sure of a sale once the items have been worn; either the customer will enjoy the feel of the clothes, or the clothes are now "soiled and cannot be sold to another", so the person **must** buy them!

BAZAAR OF DRIED PRODUCE

Here in the Sharia es **Sukkariya** can be purchased dried fruits, fish, nuts, sugar, and candles. Expedition supplies can be bargained for with the stall holders, but most expeditions choose to use the European suppliers in the modern quarter.

BAZAAR OF M E TENTMAKERS

Near the Bab el-Zuweila at the southern end of the medieval quarter is the bazaar of the **tentmakers**. Tents and traditional Bedouin accommodations are made to order. Tents made here **are** designed to withstand **desert** conditions better than those provided by European suppliers. It takes three days to make one tent to order, one week to make four tents.

TOBACCO BAZAAR

To the north of the Khan **el-Khalili** is the tobacco (*tumbaki-yeh*) bazaar. Here coarse Persian **tobacco** is sold to smokers of the **nargeeleh** and the **sheeshesh**. Other drugs for smoking can be obtained, openly before 1924, under the counter after **this** year. **The** old-world look of this area frightens off sellers of shoddy European smoking accessories. Massive doors, nail-studded and heavily hinged, close in the *welekas* (yards) where the tumbak is **stored** and dried. **Dilapidated** gateways lead into spacious khans (storehouses) where caravans from Syria and Arabia once **unloaded** their merchandise.

The Mosque of **Beybars** the Taster dominates this district. From its minaret, investigators can look down on extensive warehouses now partitioned into tenements of the very poor: the decayed houses of merchant princes with their gardens now used as rope walks (for rolling and plaiting rope) or as bleaching grounds.

GUN-MAKERS' BAZAAR

In the oldest part of the medieval quarter, next to the walls of **Saladin**, **gun** merchants and manufacturers crowd three streets in the Suq es Selah. Any firearm can be bought here, along with any variety of ammunition desired. As **many** of the guns **are** second-hand or reconstructed from parts scavenged **from** the desert **after** the Great War, **the** quality can be extremely variable and some are quite dangerous to use. Reputable merchants make their house yards available for buyers to test fire **the** guns; as a consequence the **sounds** of gunshots in this district **are** completely ignored. Prices **are** variable and bear absolutely no relationship to the quality of the gun. In theory, licenses **are** required to be able to purchase guns here; in practice **this** is ignored unless police **are** in the area. As the area is old and very dilapidated, buildings **are** in bad repair. House collapses are not uncommon; on average one will fall every month, often trapping and killing the occupants and **unfortunate passersby**.

THE NORTH GATES

At the north end of the Sharia Bab el-Futuh is the Bab el-Futuh, or Gate of Conquests. The ancient city wall links this with the Bab en **Nasr**, or Gate of Victory. These two linked gates, along with the Bab Zuweila to the south, **are** all that remain of the sixty gates in the **Fatimid** walls built at the end of the **11th** century by the vizier **Badr** el-Garnali. They provided the main base for Napoleon's troops in 1799, and the names of Napoleon's aides-de-camp are immortalized in the towers of the **Hakim** Mosque (Tour Corbin, Tour Julien, Tour **Milhaud**, and Fort Vaile).

From the east gate tower of the Bab en Nasr, a **stairway** leads up onto the top of the wall to the Bab el-Futuh. Some of the battlements are still intact, and the view **from** the battlements over the rubbish hills and slums of Cairo to the Tombs of the Caliphs is unforgettable. Designed in Roman style, the blocks that make up much of the walls **were** taken from ancient buildings, and many still show the original inscriptions in hieroglyphics.

Scenario Hook: At the Keeper's discretion, some of these inscriptions may be relevant to an investigator's researches.

QUICK GENERATION OF MARKET STALLS

Stall sells (roll 1d10): 1 Antiques 2 Shoes or hats 3 Books 4 Silks or carpets 5 Dried or **fresh** foods 6 General clothing 7 Tobacco or perfumes 8 Copper or brass 9 Jewelry 10 Weapons (**knives** or guns)

Stall is run by (roll 1d10): 1 Mustafa 2 **Seleem** 3 **Hakim** 4 Ali 5 **Muhammed** 6 **Rashid** 7 **Ahmed** 8 Giuseppe 9 Iannous 10 Joseph

Quality of goods (roll %): This is **the** percentage of items that are of good quality or genuine. An Evaluator roll is still required **from** the investigators to determine the quality of specific items.

Stall holder's attitude to investigators (roll 1d10): 1 Friendly; treats them as long lost family (-5 to roll on next table) 2-6 Neutral to friendly; they are merely customers (no modifier) 7-9 Guarded; he's hiding something (+1 to roll on next table) 10 Hostile; he hates Europeans (+3 to roll on next table)

If investigators are in trouble, the stall holder will (roll 1d10): 1 Aid them 2 Tell other stall holders 3-4 Tell all in vicinity 5-7 Run to the nearest mosque 8-10 Call for the police

PERSONALITIES

Aasim al-Rahman (antiquities merchant)

Owner of an antiquities shop near the entrance to the Khan el-Khalili. A tall elegant Arab in his late forties, with unusually elongate hands and fingers, he is courteous and polite to all. He **specializes** in tomb artifacts from the 14th to 20th Dynasties, with a particular interest in the 18th Dynasty, that of **Tutankhamun** and his stepfather (father-in-law, according to modern scholarship) the heretic pharaoh **Akhenaten**. He has a wide range of shabti, **canopic** jars, stele, scarabs, and papyri. Most items are of no great interest. The best items **are** in his private collection in the house above the shop; these he will not part with for any cost. His prices are fair, and the majority of the things he sells **are** genuine.

Prior to December 1922 he **has** heard rumors of a new, great tomb that two Englishmen are **searching** the Valley of Kings for. He suspects it may be that of **Tutankhamun**, who is said to have been buried with many riches.

After December 1922 he **has** heard of several items removed **from Tutankhamun's tomb**: "Ahh, what a magnificent thing it is **too!**" Some of these items are said to portray strange **and previously unknown** ancient gods, unlike any



found in other tombs. The curators at the Museum deny the existence of these pieces, but he has his sources and one of them **knows someone** who saw one of the item, and not two days later **fled screaming into the desert—he has not been seen since**. Aasim suspects that these **statuettes are still being held at** the Museum's laboratories at Thebes. He **has been unable to acquire them no matter how high the price; if he could, they would already be in his collection**.

In a basket of oddments at the back of his shop is a small lump of coral-encrusted something. **When handled**, a piece of the encrustation breaks off to reveal a tiny, exquisitely formed, webbed and clawed hand. If asked, **Aasim** tells investigators that it was sold to him along with a collection of items **from the Alexandria catacombs**; he does not value it highly **and will part with it for around 60 P.T.** **Once the coral has been removed (he knows a curator at the Museum who will do this overnight for a small fee) the figurine is revealed to portray a "fish-man" in superb detail, with a large fish in one hand raised in offering.**

Scenario Hook: A successful Mythos roll clearly identifies this as a deep one (Sanity loss: 0/1). This may lead to a whole stream of adventure in and around Alexandria!

Tahri Bahrin (bookseller)

A well rounded middle-aged **man** of indeterminate nationality, **Bahrin** dresses in western clothing but seems ill at ease with it. He is helpful, but drives a hard bargain and does not tolerate fools. His stall in the bazaar of booksellers specializes in old travel guides, exploration anecdotes, and ancient maps. Many of the items for sale are old papyrus scrolls, a few rarities dating from just after the time of **Alexander the Great**.



His stock includes tales of the exploration of most Arab countries, and also **from far off Cathay (China)** and the hot lands beyond (early **tales** of Australia?). **His** stock is carefully sorted by category and age; all valuable or unusual items **are** kept in a **room** at the back of the stall. (Keeper's note: This is an ideal place to allow **investigators** to buy anything needed to push them in an appropriate direction.) Examples of his stock include:

- Maps of ancient desert caravan trails showing cities that **are** now in ruins and buried beneath the sand.
- Tales from Arab traders that tell of **magnificent** palaces **and** the treasures within.
- A leaf of handwritten vellum from the **travels** of Marco Polo (an original piece of his diary?) containing **the** route to the city in the Syrian desert that destroyed Pompey **II's** troops.
- A well **worn** and fragile fragment of a copy of **Al-Azif** with no significant information on it, but which leaves

those who have looked at it with strange nightmares and an oily crawling feeling on their hands, no matter how often they wash them.

Bahrin has heard of a library of unusual and arcane books kept by the Masons in their hall across the road from the Egyptian Museum; it wouldn't surprise him if the Museum director and senior curators were members. Other rare manuscripts are held by the librarian at Al-Azhar University, and by the priests at the museum in Old Cairo. He can also put them in touch with an excellent "acquirer of desired items", a young and lithe Arab, **Badr**, who is able to find all sorts of unusual things for a price.

Hasan Karmann (expedition supplier)

Gentleman's outfitter and expedition supplier, with a large shop near the Al-Azhar University. **Hasan** is an Arab in his late sixties; the business has been in his family for twenty generations. He is able to completely outfit an expedition in less than a week, from clothing and footwear to tents, maps, **food**, camels and guides. All items can be delivered to the investigators' hotel. Two fittings are needed for clothing and shoes (these are tailored to order). He advises the use of Arabic and Bedouin-style robes instead of pith helmets and safari suits, but few foreigners pay him any attention, preferring to look proper rather than survive.



The deserts are hostile places, and few who travel them without proper equipment and provisions are able to survive. During fitting sessions he, or his staff, advises the investigators on how to find water in the driest desert (a black oiled sheet draped over a tin placed in a hole dug in the sand, with a stone to weigh down the center of the sheet, will fill the tin with water by the end of the day), or how to survive snake bite ("Do not listen to the talk of cutting and sucking out the wound, or tourniquets. Take strips of your robe and bind the limb soundly from the bite back toward the heart, and lie very still for two days; the poison with nowhere to go will merely give up and leave your body.").

The cost of completely outfitting a party of five for a desert expedition (all transport, guides, and food included) is 10 £E for the first week, and 2 £E per week thereafter. This is not negotiable: "I offer you a fair price! Do you wish to save a few piastres now and die of thirst in five days' time because I had to sell you cheaper canteens to fit your price?"

Mustapha Hamil (silk merchant)

A voluptuous man in his early fifties, dressed in the silks he sells and looking like he has a tangle of fighting tigers under his robe when he moves, Mustapha loves foreigners. As they pass his stall he leans out, blocking the tiny walkway, and shepherds them into the jewel-colored interior of his stall.



He does not **care** if they buy **any**-thing; he wishes to hear tales of the lands beyond the city and stories of their adventures: "Surely you have had many; your faces tell of things you have done that no other has done!" His neighbor Selem brings over a stool and sits down in the entrance; investigators will have to climb over him to leave without **telling** a story. A call goes out to the boy **from the nearby coffee shop to "bring coffee and sweetmeats for my excellent guests!"**

Investigators **find** it impossible to leave politely **without** telling a story. Violence is met with **regretful** disap-

Mustapha's Story

"My elder brother--may Allah protect and keep his **soul**--and I were **sifting** through the great mountains of refuse that our blessed city creates. Many who live here are fools who do not know the measure of a thing's value: Praise Allah that they do **not**! It allowed my brother and I to find things to sell to feed our family.

"**On this particular** day, my brother leaped to his feet with a great **shout**; he held a thing that gleamed brighter than the sun at noon. It was gold, my friends: a jewel of the ancient caliphs set with stones!

How did it get there? Ahh, my friends, Cairo is a city of many people, and when they die, they must be put in the ground. There is little **room**, so when those in the ground are forgotten, the room must be used for the living. The Khalili market is just such a place. When it was built, the old graves and tombs of the caliphs were tom up, and the remains dumped upon the rubbish heaps of the city.

"My brother **would** not show his prize to anyone, and held it close to his **chest** as we ran to the jewel merchant Mubarak faster than the wings of vultures. The old merchant was at first suspicious, accusing us of stealing it, but the dirt that still encrusted the stones in their setting convinced him that we told the truth.

"His eyes looked at the jewel like it was a beautiful woman, but he was a fair man. He told me to bring my mother to witness that he gave us a fair price for it. Well, you can imagine! I ran as fast as I could, but as I **returned** with my mother, we both heard a clap of thunder, an explosion!, but louder than the cannons of the fortress all firing together. The earth trembled beneath our feet.

"When we reached the merchant's house there was nothing but rubble, no fragment of brick remained larger than a man's fist, and of my brother and the merchant there was no sign."

Mustapha closes his eyes for a moment, and leans back. Suddenly he opens his eyes again, and fixes his audience with a piercing **look**.

"But that is not all there was, my friends. As my mother cried out in sorrow, the dust settled, and fell back **onto** the ruin in such a way as to form words--words that I will not forget until Allah takes me to His bosom."

Mustapha takes a pen and inscribes the flowing Arabic characters. They spell **ed dukhul mamnu, djinni binam**: 'Entrance forbidden, a **djinn** sleeps here.'

The rubble of the house is still there. Mustapha can tell the investigators where it is. None have touched it, and none from the city will.

proval, and they are cursed as they leave "with blood on your hands, and all the thousand curses of Allah upon your back!"

In exchange for a story from the investigators, **Mustapha** will tell them one in return. It is an event that happened to him when he was a **small** boy living on the rubbish piles beyond the city walls, for he has not always been as fortunate (or as large) as he is now.

Citadel of Cairo

Abdul took us along the Sharia Mohammed Ali to the ancient mosque of Sultan Hassan, and the tower-flanked Bab-el-Azab, beyond which climbs the steep-walled pass to the mighty citadel that Saladin himself built with the stones of forgotten pyramids. It was sunset when we scaled that cliff, circled the modern mosque of Mohammed Ali, and looked down from the dizzy parapets over mystic Cairo--mystic Cairo all golden with its carved domes, its ethereal minarets, and its flaming gardens. — "Trapped with the Pharaohs"

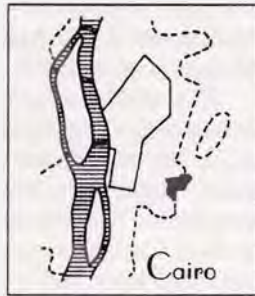

The Citadel of Cairo perches on a rocky spur above the southeast corner of the city. Behind the citadel, the cliffs of the **Moqattam** Heights rise even higher than its walls, and beyond these hills the Tombs of the **Mamluks** lead down to the rubbish hills and into the desert beyond. A high-walled medieval fortress, the Citadel was begun in 1176 by **Saladin** after he conquered Cairo following his departure from Damascus. The oldest parts of the Citadel are built of stones taken from the smaller pyramids at Giza, and many of them still show the cartouches bearing the names of the stone masons who carved them more than three thousand years before.

The area around the Citadel was first occupied in 868 A.D., and is called **El-Katai** (the wards). It is not clear what wards this name refers to, but the Citadel is considered a strong and powerful place. (Keeper's note: The wards are the ones placed by the **Wizir** of **Saladin** to keep in check the magic contained within the **Al-Azif** **Saladin** brought to Cairo.)

Saladin is the hero of many of the tales of the Thousand and One Nights. The King Shahryar and his young and beautiful storyteller wife **Shahrazade** are said to have lived in the Citadel at some time in the 13th Century. The tales she told to save her life are the tales of Old Cairo: tales of djinn and heroes, of lust and passion, of trust and betrayal. All happened here in this city and were first told within the walls of the Citadel. Now they are told by all of the storytellers in Cairo in various censored and uncensored versions, depending on the age of the audience and the size of the payment.

The main entrance to the Citadel in ancient times was the Bab el-Azab; it stands at the south end of Saladin Square. The magnificent bronze doors that once closed off this huge gate from the rest of Cairo are long gone and have been replaced by bronze-studded wooden gates, but the high guard towers still stand on each side of the gateway. **The narrow** and crooked lane beyond the gates was the scene of the massacre of the **mamluk** rulers of Cairo on 1 March 1811, at the order of **Muhammed Ali**. Only one is said to have escaped the troops and the bloodshed, Amin Bey, who rode his horse through a gap in the walls into the moat more than forty feet below.

Built by the Seljuk **Turks** who restored the Islamic orthodoxy, the Citadel was able to withstand the onslaughts of the Crusaders and many attempted invasions, but finally fell to the Ottoman Turks in 1517. In 1811 the massacre of the mamluks by **Muhammed Ali** made Cairo independent of **Turkey** and began the restoration of an Egyptian identity.

A cannon in the hills behind the Citadel is fired daily at noon, set off by an electric signal sent from the observatory at Helwan.

Saladin Square

Saladin Square, in front of the Citadel, was built at the command of Lord **Kitchener** in 1913. It was formed from the original **Rumeila** Square, and by the destruction of several small streets and buildings. It is rumored that the occupant of one of the buildings, reluctant to move, cursed the rulers of Cairo and the British **Army** with a hundred years of endless fighting. The Great War began the following year, and violent acts have been the norm in Cairo since, although Cairo has never truly been at peace at any time in its history.

A market, the Suq el-Kasr, is held in the square each **afternoon**. It is largely a produce market, with baskets of dates, oranges, bananas, apples, and vegetables arrayed in multicolored glory on the ground. Tourist items such as the everpresent replicas of pyramids, sphinxes, and mummy case ashtrays also fill stall after stall.

At the south end of the square is the Cairo Prison. A tall walled building, the walls are topped with evil spikes and broken glass fragments, and are patrolled by armed guards. At dawn and dusk the sounds of gunshots can be heard as condemned prisoners are executed.

From the northeast corner of the square the Sharia el-**Maghar**, and later the winding Sharia Bab el-**Gedid**, leads past the north edge of the Tombs of the **Mamluks** to the Monastery of the **Bektashi** Dervish sect. This monastery is open to the public, and is surrounded by palm-filled gardens. A flight of steps rises to the courtyard, which is connected to the residences of the dervishes. From the height of the gardens there is a magnificent view of the city, the Nile Valley and the desert beyond. From the courtyard a deep cavern, an old stone quarry, enters the mountainside and contains room after room filled with the tombs of the dervishes. As the rooms get deeper in the mountain they become colder, and the tombs give way to mummified bodies piled in heaps and thrown in corners

without apparent care. At the furthest point of the caverns is the tomb of an unnamed sheikh of Cairo. It is simple and unadorned; pilgrims come here to be healed.

Scenario Hook: One of the stall holders at the Suq el-Kasr was recently sold an exquisitely beautiful piece of Arabic calligraphy. Illustrations around the borders of the indecipherable script show a dead pharaoh rising again to live in the lands of the gods. Realizing he could make a bit of money out of it, he has employed a number of children to make copies of the calligraphy and illuminations. He is selling these copies at his stall. The children performing the copying keep falling ill, and he has to replace them every few days with others.

The manuscript is a fragment of the original *Al-Azif* brought to Cairo from Damascus by Saladin. Each time it is copied, the spell on the page causes a dead relative of the copyist to come back to life. The power required to perform this is drawn from the child copying the manuscript, and he becomes "ill." Soon it will be noticed that the dead are beginning to walk the streets of Cairo once more. Destruction of the original manuscript and all copies will reverse the effects of the spell.

The Citadel

The road to the Citadel begins at the northeast corner of Saladin Square. The Sharia el-Maghar, a road wide enough for carriages, and then the narrower Sharia Bab el-Gedid wind and snake up the hillside to the Citadel above. A pedestrian road, the Sharia ed Daftarkhana, also leads to the Citadel. This footpath passes the palace archives, housed in a building built by Muhammed Ali in 1828. The archives are a collection of all documents surviving from the rulers of Cairo since 1100. Here are the diaries of the advisers to the caliphs, the wizirs, said to be magics by some.

The outer court of the Citadel is entered through the Bab el-Gedid (New Gate). This is the main entrance to the Citadel, and beyond this is the Bab el-Wastani (Middle Gate). Passing through this gate, investigators are then in the main courtyard of the Citadel. In front of them is the Muhammed Ali or Alabaster Mosque, and the En Nasir Mosque is on their left.

Behind the En Nasir Mosque, a gateway leads to the former palace of Muhammed Ali, now the military hospital. It has magnificent tiled ceilings and ornate Turkish baths. Further down this lane is the small mosque of Suliman Pasha. The first mosque built after the Turkish conquest of Cairo, it was constructed in 1528. A colonnaded courtyard leads into a domed sanctuary. The walls and ceilings are tiled with script from the Koran.

Behind the Mosque of En Nasir is the Well of Joseph. Exactly which Joseph this well is named after is not known, and it is also called the "well of the winding

stairs", Bir el-Halazon. A spiral passage winds around the square well shaft to a depth of 155'. The well continues to a depth of 290'. At the 155' mark is a ledge where oxen once walked to drive the *saqiya* (or windlass) that raised and lowered buckets in the well. Near the very base of the well, the well shaft connects with a vast network of limestone caverns. These extend for hundreds of yards through the rock and are adorned with stalactites and stalagmites in weird and wonderful shapes.

Heading south from the well there is an open space containing several run-down buildings from the time of Muhammed Ali. The Hall of Justice contains broken and battered furniture, but the cellars below still contain boxes of records of trials and crimes from 1824–1898. At the eastern end of this square is the



mint, again abandoned, but scrabbling around in the dirt one is likely to turn up the occasional misformed coin and stamping die. There are rumors that the basement of the mint contains a fortune in gold and silver. (Keeper's note: There is no basement to the mint.)

The Citadel mount is also considered to be a place of significant power by secret societies, a fact **known** well to the **wizirs** of the sultans, caliphs and mamluks. The energies of the mount are **tapped** unconsciously by the doctors and nurses in the military hospital, which has a **remarkable** success rate in healing **cases** thought to be irreversibly fatal. Various sects hold rituals in the ruins on auspicious nights; they do not like to be interrupted. (Keeper's note: The Magic Point cost to open a gate from the mount of the Citadel is significantly less than from elsewhere in Cairo, but by the same token, it is harder to control things that enter our world through any gate opened at this location.)

Mosque of Muhammed Ali

Topped by extremely slender and tall minarets, this mosque was built in 1830 on the site of a palace that was blown up in 1824. Completed in 1857 by Said, it was immediately hailed as one of the prettiest mosques in Cairo. Inside it is Byzantine in style, and it is believed that the architect was the Greek Yusuf Boshna of **Constantinople**. It is similar in design to the mosque of **Osmaniye** in Constantinople. The interior columns and walls are encrusted with yellow alabaster, and all the wood used in the construction is painted to look like alabaster as well.

At the right of the entrance to the interior mosque is the tomb of **Muhammed Ali**, surrounded by a high, intricately carved wooden railing. At the **western** corner of the mosque the minaret is open to the public and the view of Cairo from the top is unsurpassed.

Mosque of Sultan En Nasir

Built in 1318–1355 by Nasir ed Din **Muhammed ibn Qalaun**, this mosque was used as a military magazine and storehouse for many centuries. It is now extremely dilapidated, and in some parts unsafe. The twin minarets are capped by bulbous cupolas encrusted with brightly **colored** faience in the Persian tradition. The dome in front of the prayer niche **rests on** ten ancient Egyptian granite columns; the dome collapsed in 1487 and only the **hieroglyph-inscribed** columns remain.

Scenario Hook: Large areas of the Citadel are in disarray and partial ruins. Below the Citadel mount are "caverns measureless to man" containing the tombs of many of the minor rulers of Cairo, as well as all sorts of artifacts from their rule.

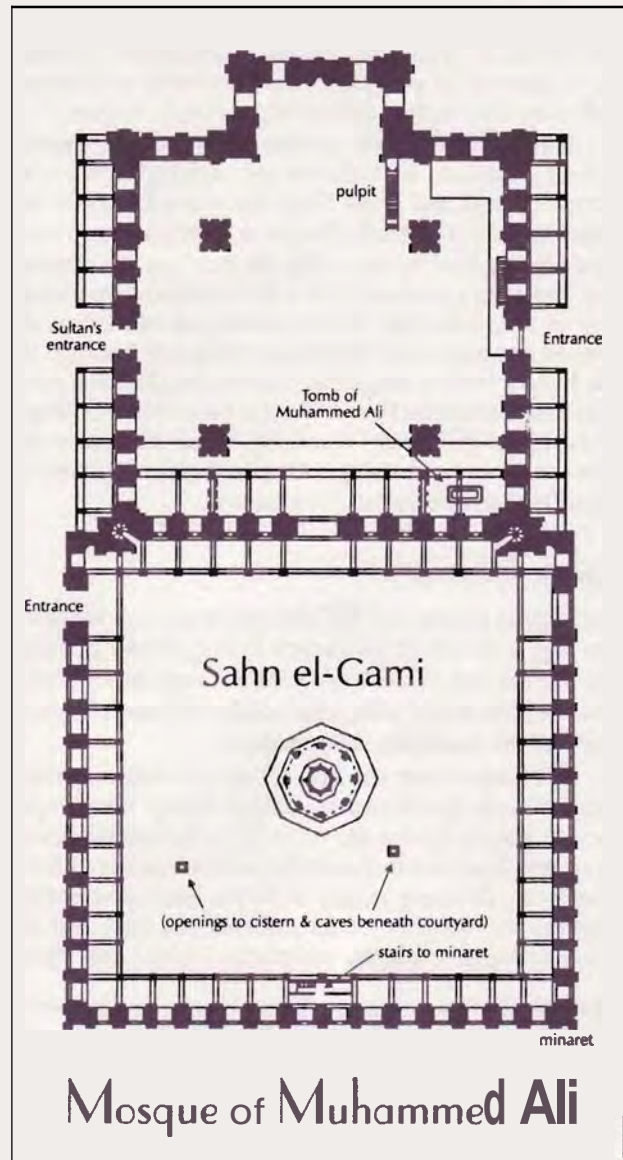

Old Cairo

Also called the Roman **fortress** of Babylon (this name is **no longer used in** modern-day **academic literature**). It can be reached via Tramways No. 1 and 15, or by train from the Bab el-Luk Station to St. George's Station.

Nilometer

On the route to the ruins and bazaars of Old Cairo, a ferry can be taken to the Nilometer on the Island of **Roda**. The cost is 20 mill.; payment is **made** on the return trip.

The Nilometer was built in 716 A.D. by **Suliman**, and now stands at the south end of a magnificent garden. A well with an octagonal column in the center inscribed with **Cufic** symbols, it was used to measure the height of the Nile in all seasons. Land taxes were adjusted according to the height of the water and the subsequent fertility

of the season. The festival of the Nile flood (the *Wafa*) is proclaimed to begin when the Nilometer reaches a height of 15 ells and 16 *qirat*, the height necessary to inundate the entire Nile Valley; this usually occurs in August.

Further north in the garden is the tree of **Sayeda** (Saint) Mandura. Its branches **are** weighed down with scraps of rags and small flags that wave limply in the slight breezes. The tree is thought to have healing powers. One **seeking** healing must offer the bandage that covered the wound, or a piece of cloth with a picture of the illness, and tie this to the tree. She must then pull two leaves off the tree and tie these to the wound with a new bandage. (If the Keeper wishes, doing this may be considered an automatically successful First Aid roll at the cost of one Magic Point to the petitioner.) Ironically, those who come too close to the tree or bandages **are** also at risk of contacting all sorts of temble and exotic diseases.

Old Cairo

The district known as Old Cairo, to the south of the modern city, is the site of the ancient Roman citadel of Babylon and the fort of Fustat el-Kahira. Large docks extend into the Nile at this point, and flotillas of large and small craft fill the river from dawn to dusk.

The narrow and winding streets are home to many dealers in the goods that are unloaded here from Upper Egypt. The docksides are crowded with warehouses of grain and fresh produce, and the pungent smells of fresh and drying fish hang thickly in the air. Narrow alleyways between the warehouses are cobbled unevenly and are home to beggars, thieves, and mangy-looking cats. Some

of these warehouses are used for the drug trade (illegally after 1924), and investigators caught near here without a very good excuse **find** themselves in serious trouble with powerful drug lords or **arms** smugglers. **Small** stalls and shops in the wider streets sell almost anything; most items are at highly elevated prices and bargaining is essential.

Across the railway line (over a rickety wood foot bridge) the walls of the Roman citadel still stand to the east of the station and within the walls are a host of Coptic churches.

At the gate to the old city are two towers. It is said that a saint lives in one, and is reincarnated in the form of a beggar who sits at the foot of the towers. Women in need of healing give the beggar baksheesh, and then nail up fragments of their own clothing. These fragments are then touched and kissed by others in need of healing.

The Church of Abu **Sarga** (built in the 6th Century A.D.) within the Citadel walls is considered to be the model for most of the other Egyptian-Byzantine churches throughout the Orient. The side walls of the basilica **are** built of marble columns taken from ancient Egyptian sites nearby, and are randomly placed in the walls of the church. The ancient inscriptions are still legible, and are silent testament to the ancient gods in a church to the new God.

Scenario Hook: What do these columns say? Where are they from? Do they drain some of the energy of worship being given to the Coptic Christian god and direct it towards the empowering of much older gods?



Steps from the side chapels descend into the crypt. Older than the rest of the church, within is a small vaulted chapel and marble nave dedicated to the Virgin Mary. The chapel is said to have been built on the site the virgin and child rested during their flight from Egypt.

There **are** several other Coptic churches and a Jewish synagogue in the citadel, mainly unremarkable. The Church of el-Muallaqa also contains the Coptic Museum, opened in 1910 by its curator and director **Morkos Pasha Simaika**. Admission is 5 P.T.; it is closed Friday and Sunday.

The museum contains a good collection of religious items and wood carvings from the Coptic churches in the citadel. At the rear of the museum a courtyard leads down a flight of stairs to the South Gate of Old Babylon (29-1/2' below the current street level), which is topped by two watch towers. The courtyard of the church, adorned with marble columns and a fountain, contains the entrance to the museum library. This library contains a good collection of Coptic and Arabic manuscripts (over two thousand in all) taken from Coptic monasteries and churches.

Scenario Hook: There is a good chance that fragments of manuscripts pertaining, perhaps indirectly, to the Mythos will be found here.

Beyond the Roman citadel is the Arabic citadel of Fustat **el-Kahira** (Fortress of Mars). This citadel was built by the Arab General **Amr** during his conquest of Egypt in 640 A.D., and between 650 and 1000 it was the center of Cairo. Excavations of the oldest parts of the city are still underway here, with new buildings being discovered every day. The structures here were filled with sand and rubble after having been deliberately destroyed when the King of Jerusalem invaded in 1166. Admission to the diggings costs 5 P.T.; they are open **from** dawn to dusk.

To the north of the excavation is the Mosque of Amr. An unimpressive building, its only unusual feature is a recess in the northwest corner holding two short columns, the top of which appear to drip blood: the blood of pilgrims who rub their tongues on the columns until they bleed in order to gain healing for other bodily ailments.

Near this mosque are factories where water pots, or *qulla*, are made. These large storage jars are made from a special mixture of clay and ash; the porosity of the **mix-**ture allows the water to be kept cool by evaporation.

Scenario Hook: Rumor says that special jars are made for city sects using the ash from sacrificed infidels.

From the eastern edge of the old town, the cemeteries of Cairo begin. The Greek cemetery blends with that of the caliphs, and to the north the dead continue in the cemetery of the **mamluks**. Between the tombs, any empty land is used as a rubbish dump, and swarms of small black biting flies gather persistently at the corners of the eyes and mouth. Vultures circle overhead constantly during the day; at night they perch on the tombs and monuments.

Museums

The Egyptian Museum

This fine museum, one of the greatest in the world, lies on the banks of the Nile off the Avenue Reine **Nazli** (formerly the **Sharia Abbas**), just north of the Kasrel-Nil Bridge. The Museum was originally founded in 1857 by the French Egyptologist August Mariette at Bulak, two kilometers to the north. It moved to its present location, a massive building in the Greco-Roman style by the French architect M. Dourgnon, in 1902. Expanded and enlarged by its later directors (Grebaut, de Morgan, **Loret**, and **Maspero**), it contains the largest and most comprehensive collection of ancient Egyptian artifacts in the world.

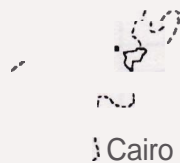

The present director is the renowned French archaeologist Pierre Lacau, who is also Director-General of the Egyptian Department of Antiquities. He presides over a large staff of conservators, including Garth Weder, Reginald Engelbach, Battiscombe "Batty" **Gunn**, **Sumi Effendi Gabra**, and **Mahmud Effendi Hamza**.

Scenario Hook: The original plans of the museum complex are lodged at one of the city departments. Close examination of the plans shows discrepancies from those published in the guide books available. There are four additional rooms on the ground floor (marked by * on the museum map), accessible only from the basement. These contain the museum's collection of Mythos artifacts, a secret closely guarded by both the director and his protégé Garth Weder. The director has little interest in these objects; he merely wishes to keep them out of the hands of the public. Weder has other plans for them, and is gradually working towards a deeper understanding of the Mythos.

Winter hours are 9:00 a.m. to 4:30 p.m. Tuesday, Wednesday, Saturday and Sunday; and 9:00 a.m. to 11:15 a.m. and 11:40 a.m. to 4:00 p.m. on Fridays. From May to October the hours are 8:30 a.m. to 1:00 p.m., and on Fridays from 8:30 a.m. to 11:15 a.m. Admission is 10 P.T. in winter and 1 P.T. in summer. Sketching, copying, and photography of exhibits are allowed in most cases, the exceptions being recently acquired pieces and any pieces associated with **Tutankhamun** (after 1923). Permission is needed to set up a camera tripod or easel **inside** the museum.

Upon leaving the Museum the visitor should have the general impression that there were "too many things to see and not enough time", and an overwhelming knowledge that the ancient Egyptians had an extreme fascination with death.

FIRST IMPRESSIONS

The museum building is huge. Made of white marble, with Greek columns running along all walls, it is a truly massive edifice out of touch with the style and delicacy of the Egyptian pieces stored within. **Two** stories high, each level is the height of a normal two-story building. It towers over the surrounding buildings in the area.

In the garden in front of the museum is a bronze statue of Mariette, the founder; behind it lies a marble sarcophagus containing his body. The main entrance is flanked by two huge pillars, on either side of which are colonnaded porches used for temporary display of recent large acquisitions to the collection.

On either side of the porches, at the front corners of the building, are two pavilions. The left hand one holds the Museum library, which is open to the public during **normal** hours, and after hours by arrangement with the director. The right hand one contains the museum shop, or

Sale Room, which has a good collection of surplus antiquities for sale to the public. All items carry a certificate of authenticity from the museum authorities. Ancient pieces purchased in the bazaars may also carry certification--the certificates and the relics are both forgeries.

The Sale Room also supplies general admission tickets which allow the holder to visit all the temples and tombs of Upper Egypt without further admission charges. These tickets cost 1 £E 80 P.T., and are valid for one year from 1 June to 31 May. These tickets are also available from Thomas Cook & Son, and from the Inspector of Antiquities at Kamak.

THE GROUND FLOOR

The ground floor holds the more massive pieces: vast statues, pillars, sarcophagi, wooden figures, granite and alabaster heads, tomb wall reliefs in glorious color. In the entrance rotunda and the great hall these are all arranged in a fairly haphazard order, by space requirements rather than by theme, age, or by site. The most recent acquisitions are also housed here in the main entrance rotunda, and a curator is always on hand to tell the public about the latest explorations and acquisitions.

Once out of the gigantic chaos of the entrance hall, the rooms and their contents are arranged in order of their historical periods.

Rooms B-D and Gallery A contain items from the 3rd-6th Dynasties, "the pyramid builders", found at Giza, Abydos, and Saqqara. Tomb reliefs, columns, and statues vie for attention with false doors from tombs, small funerary statues, and a particularly nice statue of an ape biting a man in the leg.

Rooms F-G and Gallery J contain monuments of the 11th-17th Dynasties, the Middle Empire (now considered to be the 11th-13th Dynasties; the "Empires" are now called Kingdoms). These include items from Tanis, including a small golden staff headpiece, and an especially interesting group of (frog-headed) water gods offering fishes on lotus stalks and carrying strings of fishes and birds. Room G contains the entire tomb chamber of Harhotep, and ten larger-than-life statues of the Pharaoh Sesosteris I from Lisht. Showcases contain mainly statuary and small sculptures and canopic jars. Gallery J contains several large sphinxes from Tanis in black granite; their eyes watch all who enter until they leave.

Rooms I-O and Galleries K-N contain articles from the New Empire, the 18th-24th Dynasties (now considered to be the 18th-20th). These are considered to be the pinnacle of Egyptian culture. They are finely worked and intricately inlaid, yet show a simplicity of style that is strangely compelling. Sphinxes, chapels to the sacred cow goddess Hathor, and items related to Tutankhamun found before 1920, and unrelated to his tomb, are here.

From here, the staircase to the upper floor is situated between two colossal pink granite statues: one of a seated lion, the other of a baboon.

On the north staircase are colossal figures of Amenhotep III and his consort Tiye. These are considered to be magical by poorer Egyptians, endowed with all sorts of healing powers. Those who can borrow or steal the admission price come here in a never-ending stream to stand with arms outstretched, and touch the toes of the seated figures. The rooms continue, containing sarcophagi, the falcon-headed bed of Osiris, two arms from a colossal statue of Rameses II, and statues of more kings, pharaohs, and the occasional priest or abess.

Rooms Q-S contain treasures from the Late Period, the 25th-30th Dynasties (now seen as the 21st-31st). These are beginning to show recognizable influences from the Greek and Roman periods, but are still mainly Egyptian in style. The "Pithom Stele" in Room R (used primarily as a storeroom) is a small memorial stone to King Ptolemy II. Its inscriptions tell of how the king traveled to Persia to bring back to Egypt the images of gods the Persians had stolen. It implies that he also brought back images of other gods, described on the stele as "the gods older than man himself who are worshipped by those of the dark and nameless lands beyond the known world."

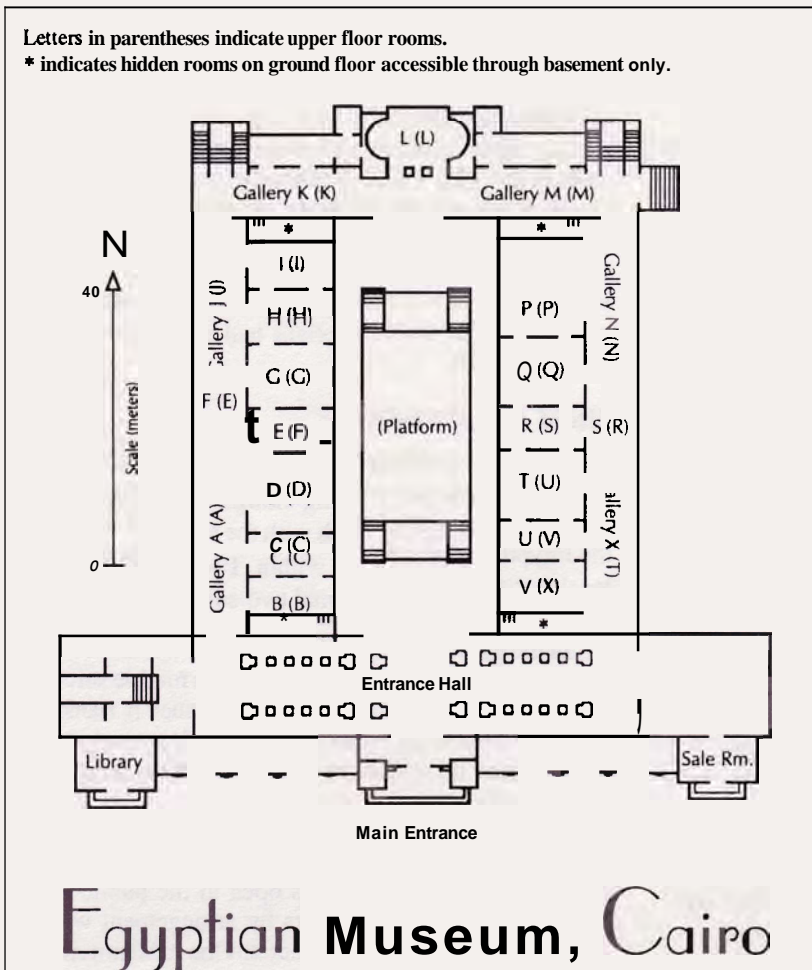

Scenario Hook: Many of the images referred in Room R to can be found in the secret rooms in the Museum (marked with * on the map), and a further section of the stele in these rooms tells of a city buried in the Persian lands that was built by the worshipers of these old and blasphemous gods. It was in this city that Ptolemy II found these images, and lost more than half his army.

Scenario Hook: Items relating to the Cthulhu Mythos have been recovered from the tomb; these can be found at the Thebes workshops. Weder knows all about them and is attempting to divine their meaning.

Room S mainly contains monuments from Ethiopia, alabaster statues and more stele, and a very powerful statue of Osiris in a Nubian style.

Rooms T-V and Gallery X contain monuments of the Greco-Roman and Coptic periods. Those who have visited the Alexandrian museum get the impression that the items here are largely the leftovers, and there is a distinct Roman feel to most of the items. There is also a mixture of ancient and modern styles, disturbing in its strangeness.

The southeast staircase leads to the upper floor.

THE UPPER FLOOR

Here are the major attractions of the museum. The Treasures of Tutankhamun exhibition opens on 14 April 1929. This incredibly valuable exhibition occupies Galleries M, N, R, and T, and the room to the north of Gallery M. Prior to this time these rooms are full of more mummies, sarcophagi, and a large (more than 2000!) collection of mummified cats. Taken from Egypt to England by Howard Carter and Lord Carnarvon, the bulk of the Tutankhamun collection is returned to Egypt in March 1929. There are more items still being prepared and catalogued at the Museum's laboratory at Thebes.

Discovered in November 1922 in the Valley of the Kings by Howard Carter, under the patronage of the Earl of Carnarvon, Tutankhamun's treasure is the greatest of all Egyptian tombs excavated to date. The quality of the artistry is superb, and the funerary furniture and statuary is the most complete. From opening time until closing each day there are queues of visitors waiting to enter these rooms, and it is the "must see" part of the Museum for all tourists to Cairo. The golden sarcophagus and funerary mask of the young king are literally stunning in their beauty, as are the small alabaster and ivory canopic jars and ornaments with their exquisite ornamentation and sculptures of Egyptian women and animals. Chariots and chairs of gold and ebony are in cabinets beside fan handles, trumpets, and staves. The king's throne stands in a separate case and is decorated with figures of the king and queen inlaid in colored stones on the back. Its arms are formed of crowned and winged serpents. There is no evidence of any Mythos influence on the items displayed.

The mask of the king is of burnished gold, inlaid with semi-precious stones and enameled with glass. It reproduces the features of the king exactly: the eyes are inlaid with white and black stone and adorned with lapis lazuli. At the back of the mask is a section of hieroglyphic text from the Egyptian Book of the Dead, describing the manufacture and importance of mummy-masks.

Scenario Hook: The text also predicts that the king will be reborn in the body of anyone who wears the mask.

The south balcony is full of sarcophagi of princesses and minor officials, and small tomb items. The room to the south of the main gallery contains busts of all the famous Egyptologists and explorers and a collection of stone tools. Off of this room is the natural history collection, with mummies of animals, a skeleton of a horse found in a wooden coffin at Saqqara, loaves of bread over 2000 years old, and seeds and oils found in the tombs that have been excavated.

Scenario Hook: Among the oils and unguents is one which induces a sleep through which the Dreamlands may be entered.

Gallery A contains more wooden coffins, mainly from the Middle Empire; all are heavily decorated, and some are inlaid. Rooms B-I and Galleries A-K contain yet more mummies, coffins, sarcophagi, and associated tomb decorations and statuary. The visitor traveling through these rooms is filled with an overwhelming sense of his own mortality, and may even begin to wonder as to his own fate upon leaving the museum.

Room L, the Jewel Room, is heavily guarded and well lit. As the visitor approaches, the gleam of gold and other precious metals can be seen from within. Upon entering the room, the wealth of jewelry is truly staggering. All the pieces are exquisitely detailed, images of animals and birds featuring prominently. Golden pectorals and collars, intricately beaded and enameled necklaces, bracelets, daggers, crowns, scarabs and vultures call to be examined. Vases of gold and silver, drinking cups in the shape of lotus flowers, mirrors of silver, earrings and golden sphinxes are displayed in all their splendor. Despite the presence of guards at the doors, and more roaming through the cabinets, there is

no **immediate** evidence of other security **measures**, although a close inspection of the **cabinets** and skylight show them to be wired for electricity.

Rooms O–Q and S–X contain **Greco-Roman** and Coptic artworks and coffins. The difference between the ancient and modern styles is immediately obvious, as if a great civilization suddenly forgot all that it was capable of.

Room P is the papyrus room. Here can be found original copies of the Book of the **Dead**, and a wide variety of texts and spells referring to life after death.

Scenario Hook: Many spells are on display and, given the appropriate language skills (Ancient Egyptian), can be copied without interference. Some of the required ingredients are difficult to find, but that has not prevented many from trying them. The common requirement of most is a freshly dead corpse and a variety of implements and tools suitable for embalming. Some of these immortality spells actually work.

FORBIDDEN ITEMS

As can be expected in any land as old as civilization itself, the museum excavations occasionally uncover items related to the Cthulhu Mythos. It is the responsibility of the Director and his assistant **Garth** Weder to ensure that these items are properly restored, catalogued, and placed where they will do harm to no one.

Four rooms on the ground floor of the Museum (marked with * on the map) are only accessible from the basement of the museum. They contain a minddestroying collection of Mythos artifacts and are difficult to enter without a key. An elder sign on the door of the stairs leading up into the **first** room provides some protection. There are other wards that have been placed on individual items within each of the rooms.

Among the items in storage here are **small** statues of deep ones and prayers to Father Dagon (from Alexandria and the delta), tablets invoking **Azathoth**, papyri containing prayers to the Black Pharaoh, Nyarlathotep (from Tel el-Amarna and Thebes), and oily fragments of vellum no more than 2" square covered in crabbed Arabic script (pieces of the original *Al-Azif* brought to Cairo from Damascus by **Saladin**). There are many other items here as well.

PERSONALITIES

Garth Weder

An Austrian expert in the restoration of wood, papyrus and cloth relics, **Garth** divides his time between the Museum workshops at Thebes and the Museum in Cairo. A regular at the **Muhammed** Ali Club, Automobile Club, and the Institut **Français d'Archaeologie Orientale**, Garth is also one of the inner circle of the Cairo Masonic Lodge and a founding member of the Golden Dawn in Cairo. He knows of the Brotherhood of the Black Pharaoh, but considers their efforts to **be** amateurish.



Attractive and charismatic, with striking **gray** eyes and strong hands, **Garth** is described by his associates as a "**ladykiller**." This description is **more** accurate than they know: **His** last four **girlfriends** never arrived home after their Egyptian holidays. Should the opportunity arise, **Garth** is quick to ingratiate himself with investigators (even allowing them access to the four hidden rooms in the Museum after hours), and **as-**sists them while monitoring their activities. **The** investigators are in mortal danger if they trust him too far.

GARTH WEDER, Muwum Curator, Murderer, and Cultist, age 44

STR 13	CON 14	SIZ 13	INT 16	POW 15
DEX 10	APP 17	EDU 16	SAN 20	HP 14

Damage Bonus: +1d4

Weapons: Knife 60%, damage 1d4 + 2 + 1d4

Pistol 50%, damage 1d8

Skills: Archaeology 80%, Cthulhu Mythos 40%, Occult 50%.

Restoration 65%, Seduction 60%; Languages: Arabic 20%, English 34%, German 80%

Other Museums

ARAB MUSEUM

Off the Square of Bab **el-Khalq**, near the Citadel. Open daily November to April, **9:00 a.m.–4:30 p.m.** Saturday, Sunday, Tuesday and Wednesday; **9:00 a.m.–2:00 p.m.** Thursday; **9:00 a.m.–11:00 a.m.** and **1:00 p.m.–4:30 p.m.** Friday. Admission is 10 **P.T.**

This museum (the *Dar el-Ahhar el Arabiya* in Arabic) was established in 1915 by **Franz** Pasha, an Austrian technical director in the Cairo Ministry. It contains works of Arabic literature and art from the 7th century onward, which were originally part of the collection of the **El-Hakim** Mosque. Many of the items here are from Fustat and from Medieval Cairo. **Twenty-three** rooms full of papyri and scrolls, weapons and armor, and carpets and intricately carved screens from harems and mosques are surrounded by walls covered with tiles of passages from the Koran. A courtyard contains tombstones from the Turkish period of Cairo.

The current director is Professor **G. Weit**, a French expert on Arabic culture and literature. His curators are Husein **Rashid** and **Hasan Muhammed** el-Hawari.

MUSEUM OF GEOLOGY

Sharia esh Sheikh **Rihan**. Open daily except Friday **8:30 a.m.–1:00 p.m.** Admission is 1 **P.T.**

A comprehensive collection of rock specimens from all parts of Egypt, **as** well as examples of typical stones from the pyramids and other ancient buildings. **The** first floor contains a large collection of fossils, including the enormous skulls of an extinct rhinoceros-like monster from the Fayoum, and two huge tortoise shells, each more than two yards across.

The director is Dr. **W. F. Hume**.

Mosques

Cairo boasts some of the greatest and most magnificent places of worship in all of the Orient. The oldest churches date from the 6th century A.D. and are found in the city of Old Cairo. The oldest mosques date from around the 7th century. Those still in use are magnificently decorated and kept, with superb mosaic wall friezes and Arabic text worked into the tiled roof decorations. Many of the smaller mosques are closed to those not of the Mohammedan faith; larger ones charge entrance fees and are not open to visitors during prayer times. Women are not **admitted** to most mosques under any circumstances.

There are also a large number of disused mosques. Many are now only used once a year for specific rites and festivals, while others are inhabited by the beggars and homeless.



Mosque of Ibn Tulun

This mosque is the second oldest in Cairo, built in 876-879 by Ahmad Ibn Tulun, founder of the Tulunid Dynasty. Almost filling a large square off the Sharia Khodieri, it fell into disarray and was not used as a mosque between 1850 and 1927. In the early years of the 1920's (until

1925) it is used as an asylum for aged men; their screams and cries echo off the high walls that surround the central courtyard. In 1928 the Egyptian **government** renewed the mosque and cleared the square around it.

It is said that the mosque was designed and built by a Christian prisoner in exchange for his **freedom**. It is unusual in that it was built entirely out of new materials; most **Cairene** mosques and churches recycled the ruins of older temples they found around them.

The walls are stuccoed brick, with intricately carved wood ornamentation. The ceilings have been largely rebuilt. The windows date from the 13th century, and are from the same period as the mausoleum-like dome in the center of the court. This dome covers the remains of an earlier wooden dome, which shades an octagonal basin used by the **faithful** to wash prior to praying.

The *sahn el-gami*, or inner mosque court, is surrounded by columns, all intricately decorated with phrases from the Koran. In the sanctuary (*liwan*) at the south end of the mosque is a **frieze** of sycamore wood, also inscribed with texts from the Koran. The Arab historian **El-Maqrizi wrote** in the late 1300's that this was wood from Noah's ark, found by Ibn Tulun on the top of Mt. Ararat.

Scenario Hook: Is this true, or just a legend? Did Ibn Tulun find anything else on the top of Mt. Ararat? How did he locate the ark? Was it really the ark, or something else?

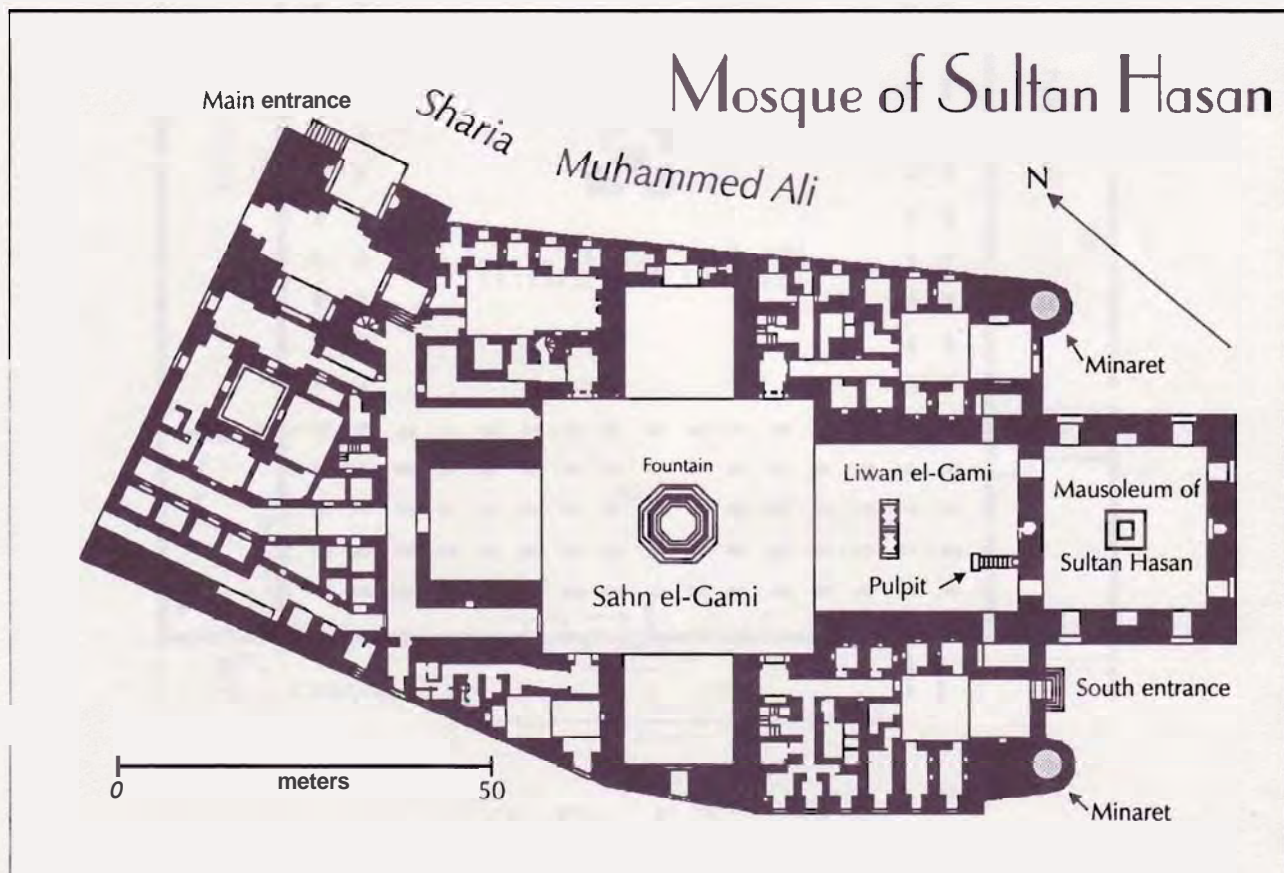

The carved ivory panels that once lined the pulpit were removed in the mid-1800's, and are now on display in the Victoria and Albert Museum in London.

The 131' high minaret can be reached by a stairway at the front of the mosque. From the top, the pyramids of Giza and Dashur dominate the southwestern horizon; to the north the beginnings of the Nile Delta can be seen. All around lies Cairo, with the roofs of the houses visible, each with its own small garden and furniture for sleeping on hot nights.

Sultan Hasan Mosque

At the north end of Saladin Square, this mosque is considered to be one of the finest examples of Egyptian-Arabic architecture. Built between 1356 and 1363 by an unknown Syrian architect, it is now used as a mosque, but

for its first three hundred years it was also used as a school. This huge building, built on a shelf of rock immediately below the Citadel, was restored during the late 1800's. From the exterior it resembles an ancient Egyptian temple, with columns topped by stalactite sculptures. The walls are broken up by recesses and false windows, but are impenetrable everywhere except the main entrance. The original massive bronze gates now stand outside the Mosque of El-Muaiyad and have been replaced by an ordinary wooden gate. The south minaret is the tallest in Cairo (at 285' high) but is not open to visitors.

The building is in the form of an irregular pentagon, with a maze of smaller rooms surrounding the central school-mosque. This takes the form of a cross, the center having the hanafiya (fountain for ritual washing before prayer), and the four arms forming the liwan (halls) used

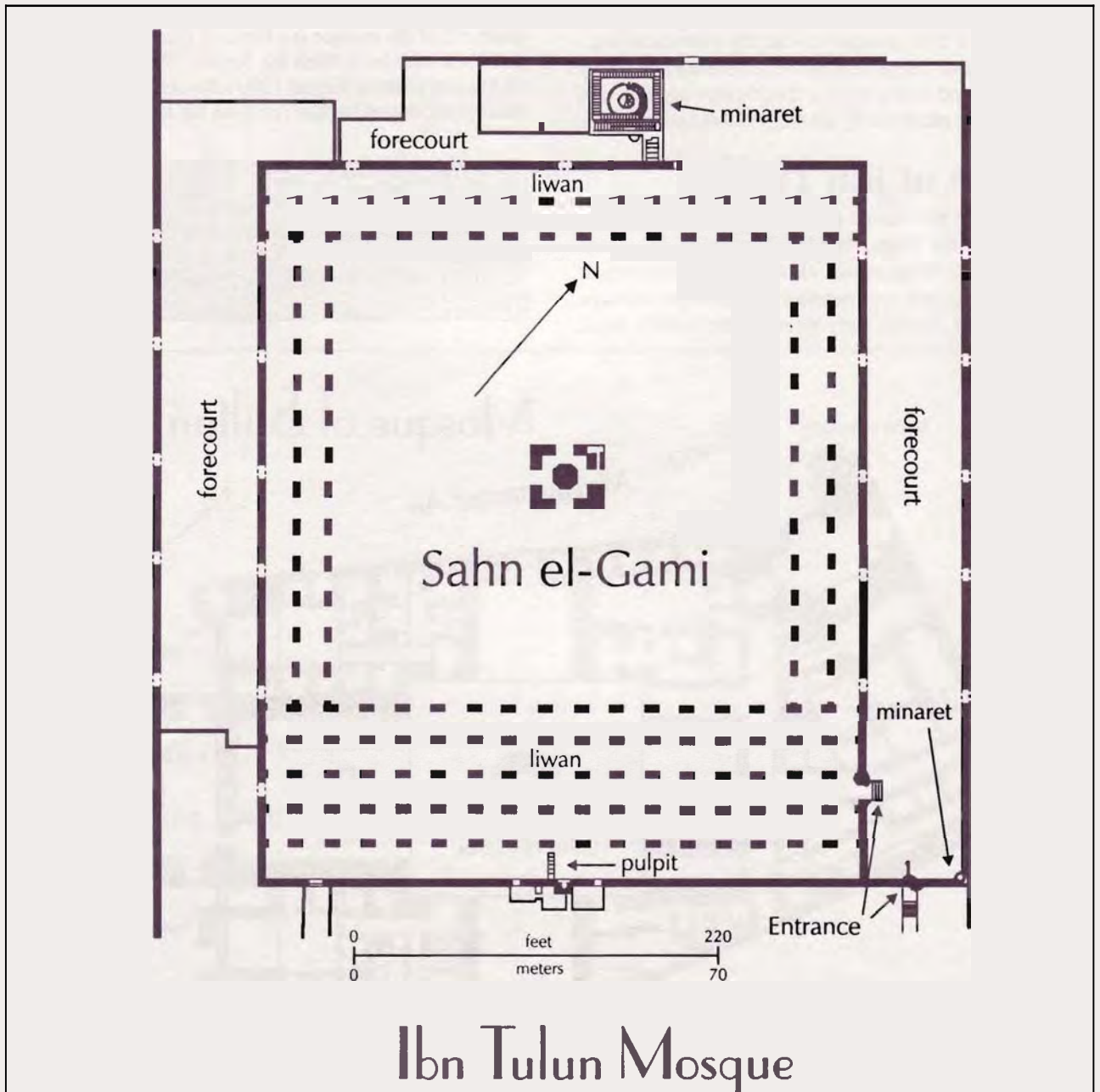

for prayer. Teaching occurred in the smaller rooms off the main cross. The walls and ceiling of the liwan and **sahn el-gami** are intricately decorated with carved and inlaid script from the Koran, and the golden chains from the innumerable lamps cut through the shafts of light that enter the building through high wall slits.

Monastery of the Mewlewi Dervishes

In the Sharia es **Siyufiya (Sharia Muhammed Ali)** on the west side near **Saladin Square**. This monastery is relatively recent, although the orders of dervishes have existed since the 12th century A.D. Originally from **Turkey**, the dervishes are well known for their whirling, stamping, dizzying dance, said by the devotees to lead them into a state of true godliness, or trance. While in this state they are able to perform incredible feats of endurance and self mutilation—piercing their chests and limbs with needles, knives, and swords; **walking** and lying on hot coals; **eating** glass and red hot coals—and all without any apparent blood loss or permanent injury. The souls of those who achieve the true state of ecstasy are considered to be absorbed by their deity. They claim that it is the will of Allah that they are able to do these miracles, and will teach any who wish to learn their methods. Their symbol is a golden five-pointed star.

Those who wish to learn must donate a large amount of money to the monastery, and the lessons last one week. At the end of this time the pupil is able to whirl around at length without feeling too nauseated. The true trance state and immunity to pain and harm cannot be theirs until they have truly embraced the ways of the Prophet.

The **zikr**, or worship display, takes place each Friday **afternoon** at 2:00 p.m.. **Bookings** are essential, and must be obtained through a dragoman (the dervishes will not deal directly with the public). Donations are requested **on** entry.

Mohammedanism

The religion of Mohammedanism, or el-Islam, is based upon the writings of the prophet Mohammed (Muhammad, **Mahomet**), born at Mecca around **570 A.D.**, who announced himself to be a prophet at the age of forty. Rejected by the people of his home city, he based himself at Medina, where he became the highest official in the city. The Mohammedan calendar's year **0** dates from this event in **622 A.D.** He captured Mecca in **630 A.D.** and died two years later. During his life he never professed to be anything other than a mortal man; after his death his followers had other ideas, and he is said to have merely been a vessel for the divine light of the prophet. The Archangel Gabriel brought him the Revelations, the Quran (Koran), which he wrote down as a book. First collated in **650 A.D.**, this work is at the heart of the faith, and is taken as the literal word of God. Mohammed is also said by some to have brought the dead to life (his parents, when reawakened briefly, embraced Islam) and to have split the moon.

The Koran itself contains few restrictions or laws other than those similar to those of the Jewish and Christian religions. The Sunna is **the** book of **the** code of conduct laid down by the prophet and his closest associates, and along with the Koran and the **Igma—the** consensus of the learned **scholars—forms** the basis of Mohammedan Law. The science of law is known **as fiqh** (recognition), and the holy law is known as the Sharia. This law contains all the rules **from** the Koran and **the Sunna** considered **appropriate** by **the Igma**. The canons of these laws are strict, and embrace **all** aspects of ordinary life. The Islamic law **courts are** dominant in daily thought, and punishment for crimes against Islam is swift, and to **Western** eyes cruel. Crimes through ignorance, however, **are** unpunished. Doubts about the word of Islam and crimes against the Prophet's faith **are** punishable by death.

The five pillars of Islam are:

- The profession of true faith,
- The repetition of daily prayers,
The payment of the charitable **tax**,
The fast during Ramadan, and
- The pilgrimage to Mecca.

Other matters dealt with by the Sharia are the laws regarding family duties, marriage, inheritance, the management of religious endowments, and the regulation of ceremonies **and** custom.

CEREMONIES AND CUSTOMS

Every day of the year, five times a day, the hours of prayer are called by the muezzins from atop the minarets of the mosques. The ululating cries of:

Allahu akbar (four times); *ashhadu anna la ilaha illa'llah*; *ashadu anna Muhammadan rasulullah* (twice); *heiya ala s-salah* (twice); *heiya ata l-falah* (twice); *Allahu akbar* (twice); *la ilaha illa'llah* ["Allah is greatest; I testify that there is no God but Allah, I testify that Mohammed is the Prophet of Allah; come to prayer, come to salvation; Allah is greatest; there is no God but Allah"]

can be heard in all parts of the city.

The hours of prayer (*salat*) are:

Maghrib—a little after sunset (the Arab day begins at sunset, not sunrise)

Isha—nightfall, about 1-1/2 hours after sunset

- Subh—daybreak, **first** light

Duhr—midday, and

- **Asr**—**afternoon**, about three hours after midday.

Every Friday the midday prayer takes place three quarters of an hour earlier than usual, and is followed by a sermon. Most businesses are **closed** from 11:00 a.m. to 3:00 p.m. on Fridays. The duty of washing before prayer is a law; in the desert sand is used instead of water. If the faithful are unable to reach a mosque, prayer is permissible anywhere.

When praying, shoes or sandals are removed and the face is turned towards Mecca. Prayers from the Koran, recited by heart, are interspersed with **kneeling** and prostration. The average prayer session takes twenty minutes.

CALENDAR AND HOLIDAYS

The Mohammedan year is **354–355** days long and consists of twelve months of twenty-nine or thirty days each. This throws the cycle of the year out of synchronization with the western year. The beginning of the Mohammedan year cycles through the seasons once every thirty-three years. In 1929 (Mohammedan year 1348) the new year begins on the evening of 8 June. Each month of the year contains important religious festivals; these are observed by all of the faithful, and some greatly disrupt the normal **affairs** of the city.

Muharram (first month): The first ten days are holy; children are not permitted to set foot on the ground, and mothers carry their children on their shoulders. The tenth day of Muharram is Ashura; a procession winds through the streets to and from the Hussein Mosque. Devotees in white robes ritually flagellate themselves with chains and swords until the robes turn red with their blood.

Safar (second month): The Mecca caravan returns at the end of this month. It enters the city through the Bab en Nasr and takes one and a half hours to reach **Saladin** Square. Twelve cannons are fired in salute from the Citadel, and the caravan then enters the Citadel through the Bab el-Wazir.

Rabi el-Auwal (third month): The first half of this month is spent in preparation for the festival of the birthday of the Prophet. The most important ceremonies take place on the eleventh day, when the whole city is lit by lamps and torches, especially the Abbasiya district at the east end of the Avenue Reine **Nazli** at the edge of the desert. Dervishes carrying flags and lanterns dance and whirl through the streets.

Rabi el-Akhir (fourth month): The festival of the birth of the Prophet's grandson. Held at the Mosque of Hussein, the Koran is read aloud for fifteen **days** and fourteen nights. The streets surrounding the mosque are full of jugglers and story tellers, shops are kept open all night, and the surrounding streets are lit by lanterns.

Jamada el-Ula (fifth month) and **Jamada el-Tanye** (sixth month) have no major holidays.

Rajab (seventh month): The festival of the granddaughter of the Prophet. This takes place for the first fourteen days of the month at the Mosque of Sayeda **Zeneb**.

Shaban (eighth month): All mosques are lit on the 14th and 15th of the month.

Ramadan (ninth month): The month of fasting. Ramadan, a fast from sunrise to sunset, begins as soon as a follower of Mohammed declares he has seen the new moon. The **dates** are variable, as they follow the lunar cycle (see the accompanying table for the dates throughout the 1920's). A **procession** led by a band travels through the city to **the Beit** el-Qadi, and witnesses affirm that they have in fact seen the moon. The fast is strictly observed during the day, but the **faithful** feast, drink, and smoke all night. At dusk people begin to fill the streets, there are storytellers in the

Year	Begins
1920	12 December
1921	31 October
1922	20 October
1923	11 September
1924	30 August
1925	22 July
1926	12 June
1927	1 June
1928	22 April
1929	12 March
1930	1 March

cafes, and the mosques are full. On the last Friday of Ramadan, the King (Prince before 1922) prays at the Mosque of Amr (the **oldest in Cairo**).

Shauwal (tenth month): **The first three days of this month are** the feast of Bairam, symbolizing the end of Ramadan. Presents are given to children, there is embracing in the

streets, and families visit **the** graves of their departed relatives. The **kiswa** (holy **carpet**) is repaired and **carried to the** Citadel in preparation for the pilgrimage to Mecca.

Dhu l'Qada (eleventh month): The departure of the pilgrim caravan to Mecca. All true believers spend the day in the streets. Harem women are dressed in their best and veiled as they look down from the open windows of their houses on to the procession below. At **Saladin** Square a tent of velvet and gold is pitched for the reception of the King (Prince before 1922) and officials. The King leads a camel carrying the Mahmal, a pyramidal wooden frame hung with embroideries and with two copies of the Koran attached to the outside. The camel is handed over to **the** Amir el-Hajj, the leader of the pilgrimage. The procession, headed by soldiers and by camels wearing ornate rugs and saddle bags, their humps covered by palm branches and oranges, sets off. Each section of the procession is preceded by musicians. The last section is the **Mahmal**, guarded by more troops. (**The Mahmal** is not sent after 1927.)

Zhul-Hijja (twelfth month): On the tenth and three succeeding days of this month is the festival of El-'id **el-Kebir** (now called **Id al-Adha**), a sacrificial feast similar to that at the end of Ramadan. Celebrating the ransom of **Ismail**, a sheep, camel, or cow is traditionally slaughtered and shared equally with family, friends, the poor, **etc**.

WOMEN AND EL-ISLAM

Mohammedanism is an all-embracing, but mainly masculine, faith. The mosques are open only to men, women are considered to be the property of men, and many laws are stated in ways that make it difficult for women to take a **man** to court. In order to accuse a man of rape, a woman must have three male witnesses to the act willing to testify on her behalf. A woman cannot divorce her husband, but a husband can easily divorce his wife merely by stating that she is divorced. A divorced woman, like a raped woman, is considered unfit to **marry**. Multiple wives are still the norm in the 1920's for most wealthy Mohammedan men. Women must travel veiled from head to foot at all times, and must be escorted by a **man** when outside the house. Many Mohammedan women, however, wield great power within the household, controlling all monetary **affairs** and raising the children.

Hospitals and Asylums

Hospitals

The central hospital in Cairo is the Kasr el-Aini, on the banks of the Nile. The city also has a large number of smaller hospitals, each run by one of the main religious or charitable groups. The main hospitals are:

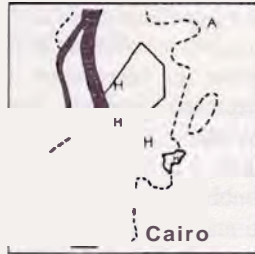

Abbas Hospital, Suliman Square (not recommended for foreigners): Egyptian run and staffed, Mohammedan.

Deaconess' or Victoria Hospital, between Reine Nazli and Wabur el-Mia on Sharia Deir el-Banat (Doctors Hegi, Luchs and Fletcher **Barrett**): German run and staffed, Protestant.

Kasr el-Aini, Sharia Kasr el-Aini, south of Garden City (the major teaching and university hospital, not recommended for foreigners): Egyptian run and staffed, Mohammedan.

Anglo-American Hospital, Gezireh (Doctors Garry, Brown, Pochin, Dolbey, Dobbin and Muirhead): English run and staffed.

St. Vincent de Paul, Abbassiya (Doctor Dunet): French run and staffed, Catholic.

Kitchener Memorial Hospital, Shubra (specializes in women and children): English run and staffed.

The **Military Hospital** in the Citadel has an enviable reputation for saving cases thought to be past saving, but is only open to Egyptian or British military men.

In addition, every church and mosque has an attached sanatorium staffed by volunteers.

GENERAL STANDARDS

The standard of health care varies considerably, and as antibiotics are largely unknown, a sick or injured investigator is more likely to become ill in a hospital than be cured. The best doctors are at the Kasr el-Aini and the **Anglo-American** hospitals: they are skilled in the treatment of rare tropical diseases, as well as the everyday patching up of **unfortunates** on the wrong end of a gun or knife.

House calls to good hotels are preferable to incarceration in a **Cairene** hospital, and there are a large number of good doctors of all nationalities residing in Cairo. Drugs are available without prescription from any of the pharmacies. Most of these cluster around the main hotels; the best are Sinclair's English Pharmacy (opposite Shephard's Hotel) and the **Anglo-American** Pharmacy (on Opera Square). Drugs of addiction are sold openly at pharmacies until 1924.

Nurses in the hospitals are kind and will do anything to help the sick. They dress in the traditional **nunlike** nurses' uniforms, and appear to the sick to glide among the beds and stretchers like angels.

Health care among the poorer inhabitants of Cairo is basic at best, with an infant mortality rate greater than 25% in the first year of life. This is partially due to the Mohammedan custom of not washing a child for the first forty days of its life, and the belief that the small black flies that cluster around the eyes and mouth can carry away disease; these beliefs lead to blindness and hideous **fly-borne** diseases in many infants and adults alike.

Marketplaces house faith healers as well as those with a knowledge of the old herbal medicines. It is **difficult** to tell them apart, and the sums charged for cures vary considerably, bearing no relation to the quality of the healing. There are also numerous beggars who are said to be reincarnations of saints with healing powers, and the sick crowd around them in search of a cure. Ironically, the practice of kissing or fondling the soiled bandages of other petitioners spreads diseases rapidly.

Common ailments of travelers to Cairo are sunstroke, dysentery, pneumonia, malaria, liver flukes (the effects of these water-borne parasites are felt many years later), rabies, and the diseases of **overcrowding**—typhoid, hepatitis, cholera, polio, and tuberculosis.

Asylums

Cairo has two main asylums. The Mosque of **Ibn Tulun** off the Sharia **Khodieri** serves as an asylum for elderly men until 1925, when it is restored to some of its former glory as a mosque. The main Cairo Asylum, or Hospital for the Insane, is at the east end of Avenue Reine Nazli (Sharia Abbas) one mile past the suburb of Abbassiya. The Cairo Asylum houses more than 5,000 patients at any one time in cramped, primitive, and dangerous conditions.

Both asylums are hideously overcrowded and offer little in the way of treatment, being more like prisons than hospitals. Dr. Gunter Fassbinder (Austrian) and Dr. Andre **Mochi** (Italian) do their best to treat foreign patients at the Cairo Asylum, but are overwhelmed by the sheer numbers of other patients with whom they must deal.

Investigators incarcerated here are at best likely to remain stable; at worst, the madness of the other **patients**—the unending screaming, gibbering, wailing, and raving—will cause their condition to deteriorate rapidly. There **are** many others here who have had experiences that may be of use to investigators, if only they can piece together the fragments of truth hidden by the insane ravings of the sufferers.

Scenario Hook: An investigator is admitted to an asylum, and discovers:

a) patients are being used for nameless experiments by sinister members of the staff, and that he is next in line!

b) clues to the identity of cult leaders and the locations of their groups in Cairo.

Coffee Shops

Throughout the heart and suburbs of Cairo every block contains at least one qahwa (coffee shop). These are not the normal western cafes frequented by both sexes; these are establishments that form the main social focus for Cairene men. Here, over sweets and tiny cups of thick Turkish coffee, pleasantries are exchanged, gossip spread, and jokes told. Here also are the games of chance and skill, from checkers and the Egyptian game of *mankaleh*, to cards (*kutschina*), backgammon (*tawla*, or *tric-trac*), and dominoes. Some also specialize in cockfighting, where two cockerels armed with steel spurs fight to the death. Although Mohammedan law prohibits betting, this seems to be ignored in many qahwas.

The size of each qahwa varies, from a collection of benches or stools gathered around a patch of charcoal and a coffee pot, to large formal cafes frequented by the wealthy and powerful. Some are the focus for gangs and sects, while others are the stamping grounds of intellectuals. Each cafe has its dedicated clientele and its patrons are found there nightly; an absence of even one night by a regular client is cause for someone to be sent to his house to make sure he is alive and well.

There are cafes for market sellers, Marxists, fascists and thieves, for generals and privates, for homosexuals and straights, for musicians and artists, for pimps and whores, for poets and police, and even for the deaf and dumb, where conversations occur by animated hand gestures in absolute silence. Every inhabitant of Cairo can find a qahwa that caters to his taste in both coffee and lifestyle.

With one qawha for every 400 people in Cairo, there are over 2,500 qahwas in Cairo in the 1920's. The perfect qawha is entered from a square in the back alleys. From the outside it is drab and unannounced; inside it is tiled with Arabic calligraphy in the Fatimid style in bright and vibrant colors. A central courtyard filled by a large spreading tree gives a sense of calm and greenness to the whole establishment. Fragrant sawdust on the dirt floor absorbs the inevitable spills and the thrown coffee grounds before the cup is refilled. On the counter at the back of the main room the large brass *sarabantina* (similar to a modern espresso machine) heats the water for the coffee. It is polished to a high gloss and is the pride and joy of the owner as it belches steam into the air. The continuous bubble of water acts to hide the exact words of conversations; many illegal acts are planned near the main counter, but only lip-readers are privy to the secrets. The proprietor (qahwagi) sits at a large table near the door, greeting all who enter and "puh-puh"ing at the day's crime figures in the local newspaper.

The term "coffee shop" is a misnomer, as both coffee and tea are served here, along with a wide variety of other drinks. Coffee is served in the Turkish or Arabic style. Introduced to Egypt by the Sufi mystics in the 16th century and used by the dervishes to prolong their trances, it was originally banned by orthodox Mohammedans. As Cairo became the hub of the African coffee trade, this ban became unenforceable in the 19th century, and it is now drunk by most Egyptians. It is prepared by adding sugar and then ground coffee beans to boiling water in a brass pot, or *kanaka*. The *kanaka* is brought to the table by the qahwagi, who pours the coffee into tiny cups while keeping most of the bitter grounds or "wish" in the pot. The customer is expected to say exactly how he would like his coffee when ordering: *ziyada* (with extra sugar), *mazbut*



Scenario Hook: Cafe Maraschino**The Appearance:**

On the corner of the Boulevard Abbas (Avenue Reine Nazli) and the Sharia Zeki, Cafe Maraschino is a three-story establishment in the good part of town. Proprietor Signor Martino, a discharged soldier from the Great War, son of an Italian father and an American mother (not looked upon well in a country where most people can trace their bloodlines back a thousand years and where marriages only occur within small tribal groups), carries on the family business to supplement his war pension. His war experiences have made him a confirmed anarchist, and defiant of the local authorities.

The Cafe is a more European-style qawha, but it is still popular with middle-class Egyptians as well as Italians and Greeks. Maraschino is also a popular hang-out for drug dealers and importers. Advertisements for Ollandia Milk, Olia di Luca and cheap Italian wines fill the windows and cover the doors. The coffee and tea served are excellent, and the establishment usually buzzes with life from midday to well after midnight. Alcoholic drinks are readily available and are comparatively cheap.

The waiters, Gad, Hasan, and Yassin, all very large and well muscled young men, serve the drinks politely and discreetly. They have occasional friends whom they bring in and are permitted to serve at a discounted price.

**The Real Story:**

Cafe Maraschino is a front for the British Secret Service. Signor Martino is in reality Bimbashi (Joseph) McPherson, former head of the Service in Cairo and now operating freelance. The Cafe is used to keep track of opium traffickers and other illicit drug dealers in the city.

Most of its patrons are importers and dealers of drugs, a clientele that "Martino" has carefully cultivated. From time to time, when he requires more information on shipments than can be gathered by conversations overheard by his agents (the waiters), he will ask the young waiters to befriend and bring in useful people. These people are served spiked drinks, and when very drunk are taken upstairs where they are thoroughly interrogated. Having obtained all the information possible they are then fed a drug that causes permanent short term memory loss and dumped in a back alley elsewhere in Cairo.

Bimbashi McPherson is a useful contact for the investigators. He knows a lot about strange events in Cairo, and while never having had any direct Mythos experiences is well aware that there are cults in Cairo dedicated to the revival of the Old Gods. He is a source for locations of secret society headquarters, and knows the home addresses of many cult leaders. He has many useful contacts in government circles, and is welcome in all high circles in Cairo.

(medium), *arriha* (just a dash of sugar), or *saada* (sugarless). The best *qahwas* serve a dark blend of beans spiced with **cardamom**.

Tea is served hot in Egyptian style. This incredibly strong brew will strip the enamel off bone china and teeth alike, and is served as **sweet** as possible in glasses. Most foreigners find Egyptian tea undrinkable. True connoisseurs claim that the finest glass of tea is only vaguely translucent, with an aroma of **kerosene** from prolonged boiling on a kerosene-fueled stove. The cost of tea or coffee varies from 1/2 P.T.—1 P.T. per cup.

Other drinks are the extremely popular hot medicinal infusions available at most cafes. These range from *ganzabeel* (ginger) for **coughs** and *helba* (fenugreek) for stomach complaints, to *yansun* (aniseed) for sore throats. Opium infusions and **teas** are also common in the early 1920's, less so in the later half of the **decade**. *Sahleeb*, a tea made from dried orchids and hibiscus flowers and topped with cream and chopped nuts, is especially popular in the winter months.

Something that hits the traveler when he enters a qawha is the thickness of the smoke that hangs in the air. All who partake of coffee and tea also partake of the sheeshah or nargeeleh, the water pipe also referred to as the hookah, used to smoke all sorts of substances. Coarse

tobacco, or **tumbak**, is common, as is *ma'assil*, a blend of chopped tobacco fermented with molasses, but hashish, marijuana and opium are also widely available. *Ghoraz*, or hashish dens, are separate from the **qawhas**, and are frequented by serious and dedicated users of drugs.

Many cafes also offer alcoholic drinks. These are frowned upon by some of the more orthodox **Mohammedan** sects, but alcohol is widely available. Most **Egyptians** only drink enough to get happily drunk, few get violent. **Home-made** brandy served on the rocks is the most popular *drink*; it varies **considerably** in alcohol content from qawha to qawha. The ice serves to cool the brandy, and the brandy kills most of the bacteria frozen into the ice (usually made from whatever water is in the pipes), but, even so, strangers often come down with severe **dysentery** after a couple of shots.

Entertainment in Qawhas

Games of all sorts are popular, and regulars have their own tables used every night, some of which have deep ruts in them caused by the ceaseless scraping and sorting of domino tiles. The most common **games** played are cards, backgammon, and dominoes, with **mankaleh** a particular favorite; checkers is also popular. Most games are

friendly, with no stakes placed on the outcome. These are merely an excuse to do something with the hands during conversations. Occasionally bets are placed, and in the more upper class qawhas the stakes can be high. Whole estates have been lost or won on the turn of a single card in a game of baccarat, and the night can turn very nasty if cheats are exposed.

Storytellers are found in every qawha. While some merely read the day's newspaper for illiterate customers, and others have been paid by wealthy patrons to recite the Koran, the best tell tales of adventure and passion from the Arabian Nights. It is almost compulsory to donate to the teller after each tale; a good storyteller can be a very wealthy man.

Politics plays a large part of the day's gossip, and in the early 1920's members of the Egyptian separatists, the Wafd, do the rounds, stirring up the populace with hope of self government and telling the locations of the next day's marches or riots. In the mid- to late 1920's all political parties send candidates around the qawhas to press the flesh; some are welcome, while others are carried out bodily and thrown into the streets.

MANKALEH

Mankaleh is played on an oblong board with twelve hollows in two rows of six each; each row forms an opposing faction. Seventy-two cowrie shells or pebbles are placed into the hollows, where they fight the opponent's markers. The game outcome is determined by the player who has won the most hollows when there are no more markers to be placed.

Games and Chances of Winning

Opponent (1d10)

- 1-2 Novice (20% Gambling skill)
- 3-5 Average (40% Gambling skill)
- 6-8 Good (60% Gambling skill)
- 9-10 Champion (80% Gambling skill)

Game Played (1d10)

- 1-4 Cards (1d4)
 - 1 = poker
 - 2 = baccarat
 - 3 = gin rummy
 - 4 = single card draw

- 5-6 Mankaleh

- 7-8 Checkers

- 9-10 Backgammon

Stakes played for

- 1-2 1d10 Milliemes
- 3-7 1d10 Piastres
- 8-9 1d10 Egyptian Pounds
- 10 10d10 Egyptian Pounds (this may be higher in very wealthy areas)

Universities

Al-Azhar University

220 yards down Sharia al-Azhar, to the east of the silk merchants' bazaar in the Mediaeval Quarter, is the University and Mosque of Al-Azhar. The mosque was completed in 971 A.D. and made a university by Caliph El-Aziz in 988. It is the oldest university in continuous use in the world. As with most Cairene mosques, women are not permitted to enter, and infidel men are allowed in only under escort.

The original building was almost entirely rebuilt after the earthquake of 1303 by the Emirs Salar and Sarghatmish, and later by the Sultans Hasan and Kait Bey. Later sultans and wealthy patrons have seen to the restoration of most of the mosque and university. Only the central part of the sanctuary of the mosque with its cupolas can be said to be in any way original.

The university is the most important in the Mohammedan world, with 246 teachers and 4838 students (1927). Of the students, only 700 are non-Egyptian, the bulk of the student body coming from Upper and Lower Egypt. The majority of foreign students come from Syria, Turkey, and northern Africa, with the rest citizens of Afghanistan, Baghdad, India, Java, Persia (Iran), Sennar, Somaliland and other countries with Mohammedan populations.

BUILDINGS

The main entrance to the university is on the northwest side of the building; a guide is allocated to all strangers upon entering. This is the Babel-Mauzaiyin (Gate of the Barbers), named so because all students once had their heads shaved upon entering the university for the first time. The gate leads into a small forecourt, with rooms to each side. To the left is the office of the university steward; it is his responsibility to maintain the ordinary running of the university. The rector of the university and the Sheikh el-Gami, Sheikh Moustapha el-Maraghi, is one of the main Mohammedan leaders of Egypt. He has rooms at the university, but is rarely in attendance.

The forecourt leads into the sahn el-gami; this is an enormous open space leading to the sanctuary. Nine rows of aisles form the principle lecture hall of the sanctuary, and there are 140 marble columns covering the area of about 3,600 square yards. The older part of the sanctuary has low ceilings; towards the rear of the sanctuary the ceiling rises considerably. The colonnaded area is poorly lit and students move like ghosts between the columns.

At the right of the sanctuary is the pulpit; further right a staircase rises to the upper story of the university. The south side of the mosque holds the tomb of Abd er Rahman Kikhya, a wealthy Cairene who paid for the addition of four aisles in the sanctuary in the 18th century. To the north and south of the sanctuary are the liwans; a large basin in the court of ablutions is used for ritual washing before prayer. The outer liwans have been con-

verted into the *riwaqs* (residences) of the Egyptian students at the university and are not open to the public.

Across the road from the mosque are the foreign *riwaqs*, the rooms that house students of el-Islam from all over the Mohammedan world. Four stories high, these tenements are a warren of tiny rooms, each less than 10' by 10' and holding as many as four students.

LIBRARY

Off the entrance forecourt, next to the steward's rooms, is the entrance to the *Madrasa el-Aqbughawiya*, the Al-Azhar Central Library. This library holds more than 52,000 volumes, 15,000 of which are original manuscripts. It is the greatest collection of literature in the Arab world.

The library is closed to foreigners and non-students alike; students of the university must gain the permission of a teacher before manuscripts are made available for examination. The works of all the major followers of

Mohammed are here. In a closed room off of the main library rooms there is a collection of ancient manuscripts from Pharaonic Egypt. These include a full copy of the *Book of the Dead* and numerous papyri containing magical spells and enchantments. The contents of this room are never available to students.

There are rumors, in certain academic and other circles, that a complete copy of the notorious *Al-Azif* is kept here, originally brought to Cairo by *Saladin* from Damascus. No one at the library recalls such a volume ever being part of the collection.

CLASSES

Classes at the university are very different from those at a western university. No fees are charged for tuition, and bread and pocket money is provided to students out of endowments made by wealthy patrons.

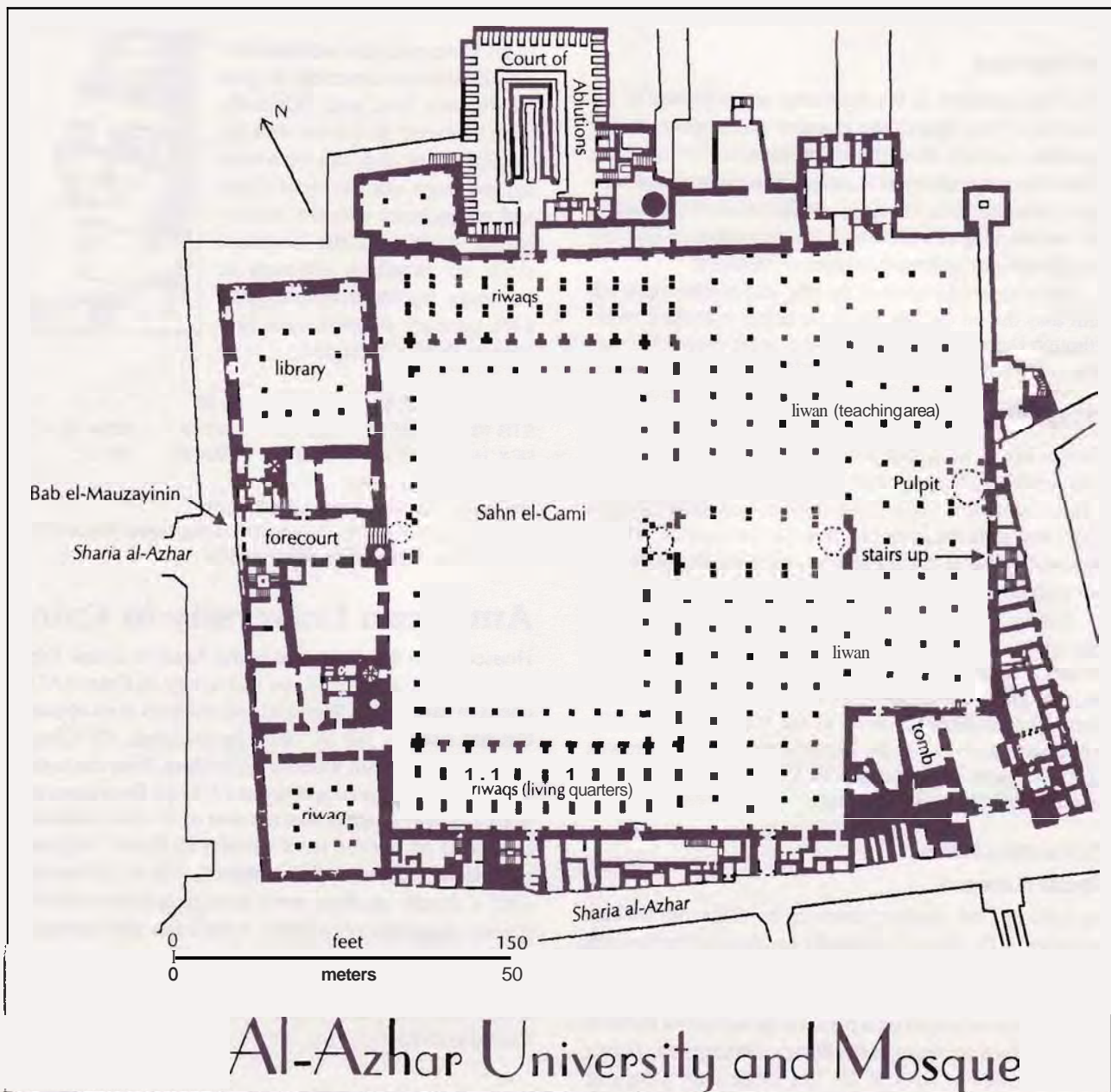

The students are here to learn the Koran and other aspects of Mohammedan law and theology. The complete curriculum of a student takes fifteen years, and the student spends much of his time sitting in a circle around a teacher. The teacher reads to the students from the Koran and other works, a line at a time, and explains each line in detail before moving on to the next one.

As soon as a student learns the lesson, and can explain the content of the book in detail, a mark (*ijaza*) is made in his copy of the work giving him authority to lecture on the subject. The student is unable to lecture until he has also passed a final examination at the end of his twelfth year at the university, which grants him the *Shahadet el-alimiya* (diploma of learning), although he is able to teach at elementary schools after passing the preliminary examination at the end of the eighth year.

The full fifteen years of study allows him to specialize further in an aspect of Mohammedan life or law. After the successful completion of another examination he is granted the *Shahadet et Takhassus* (diploma of specialization).

LECTURERS

All of the lecturers at the university are graduates of the university. They specialize in either preparatory studies (grammar, syntax, rhetoric, logic, versification, algebra, arithmetic and traditional science) or in professional subjects (jurisprudence, theology, explanation of the Koran, and the teaching of traditions). Western subjects like history, geography and mathematics are optional.

All lecturers are tenured for life, and continue to teach until they die on the job. Most are happy with their work, although there are a few who feel that the curriculum has little relevance in the modern world of the 1920's.

STUDENT LIFE

Student life is hard, and few compromises are made for those unable to keep up with the pace set by the lecturers. A firm regimen is maintained from before dawn to midnight, and students have one free day per month. All are expected to live in the university—even locals—and contact with strangers is strictly policed by older students.

During the mid- to late 1920's many student strikes take place, usually involving the students marching en masse through the streets to protest at compulsory changes to the curriculum made by the Egyptian government. The students involved in the marches are usually polite and passive; it is the locals attracted by the crowds who use them as an excuse to loot and pillage as the masses move through the streets.

PERSONAL —

Khalil Kareem

An authority on Arabic manuscripts of the 6th to 12th centuries A.D., Khalil is initially cautious of the investigators. His best student, Ibrahim, accompanies the investigators at all times while they are on university grounds. Once the investigators gain his trust he will allow Ibrahim to do research for them in the library. He recoils in horror at the mention of *Al-Azif*. He has never seen a copy in

Cairo, and does not believe that such a blasphemous thing still exists. He is sure that there is no copy in the university library. He has heard stories of a mamluk group who are said to work against the ancient cults in Cairo, and believes they can be contacted at The Prophet's Grace restaurant.



KHALIL KAREEM, Lecturer at Al-Azhar University, age 59

STR 10 CON12 SIZ 11 INT 15 POW12
DEX 15 APP 12 EDU 19 SAN 60 HP12

Damage Bonus: None

Weapons: Fist 50%, damage 1d3

Skills: Calligraphy 85%, History 80%; Languages: Arabic 95%, English 60%

Ibrahim Amin

In his fourteenth year at the university, Ibrahim is expecting to gain his diploma next year. Originally from Morocco, he knows well the discrimination that can be shown against those not native of Cairo and sympathizes with the investigators' problems. His language skills are excellent, although he has some trouble translating pre-14th century manuscripts into modern Arabic or English.



IBRAHIM AMIN, Senior Student, age 28

STR 13 CON10 SIZ 13 INT 15 POW13
DEX 16 APP 14 EDU 17 SAN 65 HP 12

Damage Bonus: +1d4

Weapons: Fist 55%, damage 1d3 + 1d4

Skills: Calligraphy 70%, History 60%; Languages: Arabic 85%, English 70%, French 60%, German 40%

American University in Cairo

Housed in the former palace of the Khedive Ismail Pasha built in 1878, the American University in Cairo (AUC) opens in early 1920. With just 142 students at its opening, this has risen to 369 by 1930. Its president, Dr. Charles Watson, offers a full western curriculum. Fees are high—16 £E per year plus an additional 13.50 £E for compulsory noon meals—meaning that the cost of an AUC education is beyond all but the most wealthy in Cairo. Originally only male students were admitted, but by the middle 1920's female students were becoming more common, mainly daughters of wealthy Americans and Europeans stationed in Cairo. Emphasis is placed in teaching not only the academic curriculum, but also moral and physical well being, with compulsory classes in physical education and Christian morality. —

The majority of senior staff positions are filled by Americans, with Arabic staff becoming more common towards the end of the 1920's. Faculty and staff in the 1920's include:

Arts and Sciences: Principal Dr. Robert S. McClenahan. Tall and heavily built, he is an outgoing and jovial Scot.

Department heads:

■ Science: Herbert W. Vandersall (Physics and Chemistry), Dr. Carl McQuiston (Biology and Chemistry)

■ Mathematics: Ismail Hussein Mustapha

■ Geography: Ibrahim Messiha

Geology: Dr. Patricia Vickersley (the only female department head at the university)

■ Education: Russell Galt (Masters, Columbia)

English: Dr. Wendell Cleland; most other instructors here are on short term assignments, and include Earl Moser and Roderick Matthews from Grinnell College, Ralph Douglas from Monmouth College, and David Day from Miskatonic University.

■ Oriental Studies (opened in 1921): Arthur Jeffrey. An accomplished linguist and scholar on early Islamic history, Jeffrey is a tall, tanned Australian.

Administration:

■ College Officer: Istafanos Khalil; checks the roll at assembly, delivers messages, and dispenses discipline.

■ Chairman of the Board: Dr. William B. Hill; elderly, rarely at the university.

■ Secretary and Assistant: Anna Lister; a no nonsense woman, able to find any item, no matter how small or insignificant, at a moment's notice.

■ Treasurer: Joseph M. Steele; middle-aged and business-like, rarely on campus.

BUILDINGS

Ornate iron gates on the Kasr el-Aini open onto a courtyard in front of the French-style palace. Three stories high, the building is opulent and impressive from the outside, and equally impressive inside. Large hallways, decorated and tiled in the Arabic style, run down the center of each wing; footsteps echo from the wooden floors. Lecture halls are large and high-roofed, with tiers of seats for students and large wood lecterns for the lecturers at the front. The former Turkish bathhouse has been converted into the men's showers; few other universities allow their football team to wash in such luxury.

Science laboratories are fitted out with the latest equipment, each student having his own basic set of retorts, beakers and test tubes. Athletics fields north of the main building are used by all students at least three times each week, with sports including football, baseball and hockey. Separate basketball and tennis courts are also constantly in use, with the AUC basketball team being described in 1925 as "the strongest, not only in Cairo but in all of Egypt."

Graduation ceremonies take place on the sports field, in the traditional ornately embroidered red tents used by Egyptians for all ceremonies. The British (later Egyptian)

Scenario Hook: An advertisement is placed in the International Student Volunteer "Bulletin" for staff at the new university in Cairo. They require people for "one of the choicest tasks on earth", specifying individuals of "clear, strong, uplifting, and moral and spiritual character." Salaries are not high, but all travel, accommodations and food are provided, and staff members are given eight days free each month for personal research programs.

Army band plays before and after the ceremony and tables outside on the field groan under the weight of cakes and punch bowls.

A new extension to the university, to the south side of the old palace on the Sharia Sheikh Rihan, opens in 1928. With larger lecture halls and purpose-built offices and laboratories, it enables a considerable increase in the number of students the campus can handle.

LIBRARY

The library is large, with donations of books arriving daily from American universities and wealthy patrons. While not a comprehensive collection, there is a good selection of works on the exploration and history of Egypt. David Day (English Department) has a small private collection of occult texts. A separate library in the School of Oriental Studies has an extensive range of Mohammedan texts and manuscripts.

STUDENT LIFE

Classes begin each day at 8:00 a.m. on Monday through Friday. Standard dress for students is suit and tie; many also wear a red tarbouch on their heads. All are greeted at the gate by Istafanos Khalil, who praises those who have done well and encourages those falling behind to study harder. The average student takes over thirty hours of classes each week.

The majority of students are locals, from the Christian, Jewish, Greek and Armenian communities in Cairo. There are no accommodations officially provided for those from outside Cairo until 1925, although some of the staff allow good students into their families and houses. In 1925 the AUC Hostel opens across the road from the university, and houses thirty students and a permanent caretaker and matron.

The low student numbers allow most to know each other by sight if not by name, and strong friendships and loyalties develop. The atmosphere on the campus seems more like that of a private club than that of a traditional university.

Students not meeting the standards of excellence set are expelled, as are those found breaking the strict code of behavior set by the President. Once a student enters the grounds in the morning he is not permitted to leave for any reason until classes end for the day. Smoking is not permitted by students or academics, and gum chewing is actively discouraged. Taking lunch in the cafeteria each day is also compulsory; the only language permitted to be

spoken during lunch is English. Insulting a lecturer results in a four-day suspension; theft is punished by expulsion and the placing of a public notice in the Cairo newspapers. Cheating on examinations is punished by isolation: No one is permitted to acknowledge the student's existence except the lecturer teaching at the time.

Students who wanted to join the protest marches in the early 1920's were initially threatened with expulsion if they failed to attend classes on the days of the marches. On the actual day they were **permitted** to attend if they showed their best behavior and **carried** a placard or banner acknowledging the AUC.

A campus newspaper, the AUC *Review*, begins in 1924, and carries both articles and fiction. Many of the stories are in the style of popular American authors, including H. P. Lovecraft.

The student union encourages the formation of special interest clubs such as the Masker's Club (Drama), the **Rameses Society** (Literature), and the Science Club.

PERSONALITIES

Patricia Vickersley

A strong-minded and athletic woman in her late forties.



Pat is the **chairman** of Geology at the university. An **expert** in the geology (rocks) and palaeontology (fossils) of Egypt, she has led many expeditions to study the geology of the western desert regions. Undaunted by Cairene men and their chauvinism, she does what she wants when she wants, and can regularly be found in her office after midnight. She is able to provide investigators with recent maps (topological and geological) of most parts of Egypt, and also with her own personal sketch maps (incomplete) of the limestone caverns under the Citadel.

Professor PATRICIA VICKERSLEY, Geologist, age 47

STR 12 CON16 SIZ 11 INT 17 POW14

DEX 14 APP 13 EDU 19 SAN 70 HP 14

Damage Bonus: None

Weapons: Pistol 60%, damage 1d6

Shotgun 55%, damage 4d6/2d6/1d6

Skills: Biology 60%, Geology 85%, Navigate 70%, Orate 60%

Margaret Ainsworth

Peggy is the oldest daughter of a senior staff member at the American Embassy. She is in her final year of a Science degree at the American University, and has lived in Cairo for six years. She finds the restrictions placed on her because she is a woman ridiculous and ignores them pointedly. She has been forcefully evicted from most of the best clubs in Cairo and is proud of it. With con-



tacts and fiends in all of the best circles, and with "Papa" a member of all the right clubs, Peggy is a **useful** friend for the **investigators**. **Dressing** in male clothing, she is willing to show the investigators anywhere in Cairo they want to go. Peggy is also a close friend of the son of Russell Pasha (the Chief of Police).

Miss MARGARET (Peggy) AINSWORTH, Student and Feminist, age 22

STR 11 CON13 SIZ 10 INT 14 POW12

DEX 15 APP 15 EDU 16 SAN 60 HP12

Damage Bonus: None

Weapons: Hockey Stick (club) 75%, damage 1d6

Shotgun 50%, damage 2d6/1d6/1d3

Pistol 45%, damage 1d6

Skills: Bribe 90%, Disguise 65%, Fast Talk 50%

Egyptian University

Housed in the palace of Ez **Zafaran**, at Abbassiya, the Egyptian University was founded in 1908 and named the official state university in 1925. Comprised of three different campuses by the end of the **1920's**, it has faculties of Medicine (the **Kasr el-Aini Hospital**), Law (on the west bank of the Nile opposite the Zoological Gardens), and Arts and Sciences (at Abbassiya). Organized in the **western** style, it has over 2000 students by 1929. Teaching staff are both Egyptian and Western, with professors of eleven nationalities. The majority of students are Egyptian. It has few resources of use to investigators.

Animals

Cairo Zoological Gardens

On the west bank of the Nile, on **tram routes** 14 and 15, the Cairo Zoo is one of the best in **Africa**. It is open from 8:00 a.m. to sunset daily. Admission costs 5 mill.; an extra 5 mill. gets the visitor a map of the zoo. It has a large variety of African and Oriental animals—many rare and endangered **species**—**each** kept in the tiny concrete and iron cells so popular in **zoos** of the **1920's**. The animals pace back and forth endlessly along paths worn inches deep in the cement floors of their cages, or lie listlessly in shaded **corners** amid the stench of their own urine and feces.

Elephant and camel rides can be taken around the zoo, and the elephants and apes perform two circus-style shows daily. The gardens surrounding the animal cages are 52 acres of carefully tended and watered, **European**-inspired botanical wonderland, with an excellent collection of palms. At the southern tip of the gardens is an **ornamental grotto**, with cave-like passages, **all** above ground level. Admission to the grotto is an additional 1 PT.

On either side of the zoo are the School of Agriculture and the School of Veterinary Medicine, branches of the American University.

Scenario Hook: A Cairo cult, the Children of the Sphinx, is stealing animals from the zoo. Each night another animal disappears. The cage bars are forced, but other animals in the cage are found cowering in the corners in the morning; they have not escaped. Each animal is the animal half of one of the anthropomorphic ancient gods. Stolen so far are a crocodile (Suchos), a lion (Sekhmet), a wolf (Wep-wawet), a jungle cat (Bast), an Indian cow (Hathor), a mountain sheep (Khnum), an ibis (Thoth), two vultures (Mut and Nekhabet), a falcon (Horus), a frog (Heqit), and a jackal (Seth). Two days after each theft, the decapitated body of each stolen animal is found outside the grotto in the park. Zoo keepers are mystified, and despite patrolling guards no one has seen anyone breaking into the cages or in the grotto at night.

The Children of the Sphinx are conducting nightly ceremonies in which the heads of their members are replaced with the heads of the stolen animals, thus reincarnating the ancient gods. The cultist becomes imbued with the powers of the god, and after a few weeks is able to use them at will. Although magically masked, the thieves can be detected with the aid of talismans available at the market and then followed to their underground temple beneath the grotto. The most recent cult recruit, Guthbert "Berty" Bramwell, is still to be reheaded. His mother, Lady Bramwell, is in Cairo looking for him.

Egyptian Animals

Statistics are provided in the Call of *Cthulhu* rulebook for Nile crocodiles, African elephants, lions, and rhinoceri. Other animals likely to be encountered in Egypt are camels, hippopotami, hyenas, jackals and vultures. For vultures use the condor statistics in the rulebook.

Dromedary Camel (*Camelus dromedarius*)

A native inhabitant of the deserts of Africa, these single-humped camels are invaluable to the desert-dwelling nomads of Egypt and the Saharan and Libyan Deserts. They are readily domesticated and ridden, and provide transport, food, milk, and shelter for their masters. Camels calve every two years, the calf staying at heel until it is weaned after one and a half years.

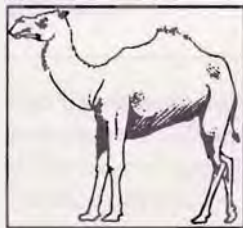

characteristics	rolls	averages
STR	3d6 + 14	24-25
CON	3d6 + 8	21
SIZ	4d6 + 10	26
POW	3d6	10-11
DEX	3d6	10-11
Move 10	HP 23	

Av. Damage Bonus: +2d6

Weapons: Bite 50%, damage 1d6+db

Armor: 2-point skin

Sd: Find Water 60%, Move Quietly 40%

Habitat: Saharan Africa, Middle East, and Australia (introduced in mid-1800's)

Nile Hippopotamus (*Hippopotamus amphibius*)

More at home in the water than on land, these gray barrels with legs are not the comical animals they are often portrayed as in literature. They are fiercely territorial in the mating season, the males attacking anything that ventures into their part of the river with their 8"-12" long tusks. They spend most of the day almost entirely submerged in water, emerging from rivers and lakes at sunset to feed on grasses and low shrubs along the banks. They exude a pink sweat from their heads when stressed; it was once thought they sweated blood.

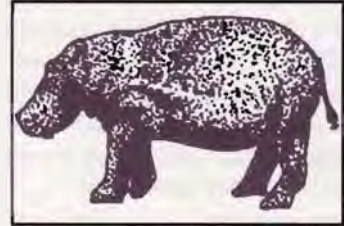

characteristics	rolls	averages
STR	6d6 + 15	33-34
CON	3d6 + 6	20-21
SIZ	6d6 + 15	36
POW	3d6	10-11
DEX	2d6	7
Move 7/12 swimming	HP 28	

Av. Damage Bonus: +2d6

Weapons: Bite 40%, damage 1d8+4+db

Armor: 3-point hide

Skills: Attack Boats 40%, Wallow in Water 80%

Habitat: Rivers and lakes throughout Africa

Hyena (*Hyaena hyaena*)

A pack-hunting dog-like carnivore, the hyena is known best for its cry—a sniggering cackling laugh. When heard at night strong men have been known to quake in fear. Hyenas live and travel in large family groups of 8-14 individuals. The females give birth to two pups every year; the first pup when barely minutes old always attacks and kills its twin as it is being born. They rarely attack humans.



characteristics	rolls	averages
STR	2d6	7
CON	3d6	10-11
SIZ	1d6+2	5-6
POW	1d6+6	9-10
DEX	2d6+6	13
Move 14	HP 8	

Av. Damage Bonus: -1d4

Weapons: Bite 10%, damage 1d6

Skills: Identify Weak Animal 80, Listen 70%, Track 70%

Habitat: Plains Africa

Jackal (*Canis aureus*, *Canis mesomelas*, *Canis adustus*)

Once they were plains hunters, hunting and catching small rodents, lizards, and large insects at night. Now they find a much easier living scavenging off the rubbish dumps that surround human settlements. Their yipping bark travels a long way at night. By day they are shy and secretive. Three species are common to Egypt: the golden jackal, the black-backed jackal, and the side-striped jackal. Their litters are usually six to eight pups. Many jackals that scavenge in Cairo carry rabies; their bite **can** prove fatal.



characteristics	rolls	averages
STR	1d6	3-4
CON	2d6+2	9
SIZ	1d6	3-4
POW	1d6+4	7-8
DEX	2d6+8	15
Move 14	HP 6	

Av. Damage Bonus: -1d6

Weapons: Bite 10%, damage 1d6-2

Skills: Crack Bones 40%. Detect Hidden Food 80%, Dismember Corpse 60%

Habitat: Plains Africa and rubbish dumps

Camel Market & Racetrack

At Embaba, on the west bank of the Nile near the terminus of the No. 6 tram, is the haphazard sprawl of tents and temporary pens that is the Suq **el-Gamal** (camel market). Here **camel** trainers and breeders sell and trade their animals to each other, as well as hire them out to European tourists.

The camels burble and roar as they are led forward for inspection by a rope tied to a wooden peg inserted through their left nostril. They sit and rise on command, and can maintain a running pace for hours through the desert if required to. These are dromedary camels, the short-haired single-humped camels of Africa; their humps are fat stores, not water-filled as some old tales say.

It costs between 15 P.T. and 30 P.T. per day to hire a camel, and they are sold for prices varying from 20 £E to 2000 £E; their owners drive very hard bargains. The quality of the camel and its usefulness is directly related to the amount paid for it. A good camel is able to travel for up to a week without water, but must be fed daily on grain or straw. It **can** travel up to 50 miles per day in good conditions, and a female camel with calf in tow can be milked for two pints of drinkable **milk** daily. A **camel** can carry up to 500 pounds of goods and rider, but prefers to travel with less than 300 pounds.

A male camel in "must" (in heat) is a strange and terrifying sight. A special pouch under his tongue inflates with his breath, and this monstrously swollen and bulbous tongue wobbles out of the corner of his mouth. In addition he secretes an incredibly sticky, foul-smelling, thick white saliva that bubbles and oozes out of his mouth and spatters on anyone or anything nearby. While in must a camel is

uncontrollable, and makes an unusual wobbling hooting cry. He will mount any female camels nearby, and fights break out between rival males for the females. They are totally oblivious of any unfortunate humans caught between them and their intended targets.

Behind the camel market, a fenced oval **racetrack** is used for weekly camel **races**. Jockeys three and four **years** old ride the camels at blinding speeds **around** the **track**, and **tens** of thousands of pounds are gambled by wealthy Arabs at each meet. The royal family are regular attendees.

Muhammed Yehya

A Bedouin Arab, he is dark and dashing handsome. Women find him attractive, and he knows it. The deserts



of Egypt and all Arabia are his home; he recognizes no national boundaries, **armies** or police. Able to read the changing sands and moods of the desert as another reads the morning paper, he can find his way to anywhere the investigators wish to go by the **mini**-mal path. He is entirely **trustworth**y, which is more than **can** be said for his assistant Salib Hannah. Salib is always **looking** for a way

to better his place in life and is entirely **open** to **bribery** and **corruption**. Salib will happily lose the investigators for a price.

MUHAMMED YEHYA, Bedouin Camel Driver and Breeder, age 31

STR 14	CON 14	SIZ 13	INT 14	POW 14
DEX 14	APP 16	EDU 11	SAN 70	HP 14

Damage Bonus: +1d4

Weapons: Rifle 70%, damage 2d6 + 4

Knife 60%, damage 1d4 + 2 + 1d4

Skills: Navigate (Desert) 90%, Ride 90%, Seduction 60%, Survival (Desert) 85%; Languages: Arabic 55%, English 20%, French 25%, German 15%

Cemeteries

We concentrated on the mediaeval Saracenic glories of the Califs whose magnificent tomb-mosques form a glittering faery necropolis on the edge of the Arabian Desert.
— "Trapped with the Pharaohs"

Cities of the Dead

The inhabitants of Cairo and Egyptians in general have historically had a fascination with death, dying, and the certainty of rebirth or resurrection. Ancient Egyptians believed that death was merely another phase in life, and went to extreme lengths to ensure that the departed were properly prepared and equipped for their great journey.

The dead are still an important part of daily life. Funerals are festivals to be celebrated, and funeral processions are noisy and long as they wind their way through the streets towards the cemeteries. Professional mourners precede and follow the coffin, beating their breasts and pulling their hair as they cry and moan for the departed. In the 1920's, as now, on Thursdays, Fridays and Saturdays it is common for families to visit their deceased relatives and to have picnics among the graves and tombs.

Cairo is surrounded to the east and south by cemeteries, both old and new. These are now called the Cities of the Dead. In the 1920's they are referred to separately as the Tombs of the **Mamluks**, the Tombs of the Caliphs, and the more modern Coptic, Presbyterian, Catholic, and Jewish cemeteries. Ornate tombs are a feature in all of the cemeteries; in many cases they are empty, the contents having been looted and the bones used for **everything** from medicines made from ground bone to carved "ivory" beads sold to tourists. Many of these tombs are the size of four-story apartment buildings. Some of them, the **mausoleum-tombs** and the **monastery-tombs**, house the living as well as the dead.

Many tours can be arranged to the older cemeteries. Indeed, tour organizers and travel agents advise those wishing to take them to do so on a night of the full moon "for a **true** appreciation of the Mystic effect", or at least to see them at sunset when they are "most **striking**."

TOMBS OF M E CALIPHS

Travel down the **Muski** and through the market quarter until the city is left behind and the Windmill **Hills**, or Tel Qat el-**Mara**, are reached. These mounds of rubble and potsherds are the remains of the rubbish thrown out by the locals for over 800 years. Small children and whole families make a living sorting through the discards for items once considered to be junk, now sold as treasures. The road winds several times and then reaches the still-used Mohammedan cemeteries of **El-Qarafa** esh **Sharqiya** (East Cemetery). On each side of the main street are large mausoleums, used to house the bodies of the dead during the ceremonies that must be conducted before interment.

Further east is the Northern Cemetery, or the Tombs of the Caliphs. In the 13th century A.D. this area was a hippodrome, with stands for public viewing of spectacles such as horse and camel races; it was only converted to a cemetery in the 14th century.

Despite the popular name, there are no caliphs actually buried here. The occupants of these tombs are the Circassian **mamluks**, not caliphs. The original caliphs of Cairo, the **Fatimid** caliphs of the Shia sect, were buried in El-Kahira. The construction of the **Khan el-Khalili** marketplace and the medieval city resulted in the tombs of the caliphs being destroyed and the bones of the caliphs along with their tomb goods being thrown onto the Windmill Hills, or rubbish hills, that the investigators pass through on their way to this spot.

The first of the older tombs encountered is that of **Kait** Bey, and beyond that are the tombs of Bars Bey and Barquq. Each tomb follows the same design: a square to elongated tomb and mosque beside one or a pair of **three-**

stage minarets, each having a square base, an octagonal second story and a cylindrical upper story (minaret) carved elaborately and topped with a bulb-like dome.

Tomb-Mosque of Kait Bey

Built in 1474 and restored in 1898, this is one of the finest of the Tombs of the Caliphs. Its dome and minaret are long and perfectly proportioned. The main decorative theme is of stalactites, and carved stalactites drip **from** every surface of the tomb. The tomb and mosque complex is a complicated labyrinth of **rooms**, entered by walking down a marble staircase. Inside the **sahn el-gami** a marble mosaic of Koran text covers the walls. Within the tomb itself there is a finely carved table and two stones said to have been brought from Mecca by Kait Bey. They bear the impressions of the feet of the Prophet and have been **attributed** with all sorts of healing and miraculous powers. An adjacent hall contains the tombs of Kait Bey's four wives. Off of the **sahn el-gami** is a small staircase leading down into a library. This once contained handwritten **copies** of the Koran and other Mohammedan texts, but it has since been emptied.

Tomb of Bars Bey

Completed in 1432, this tomb includes a mosque, a mausoleum, and the ruins of a convent and of a sibil (fountain). The wall also houses the tombs of the relatives of Bars Bey. The convent was dedicated to Mohammed, and fell into ruin after 1700. It is possible that various artifacts may still exist in the ruins of the convent.

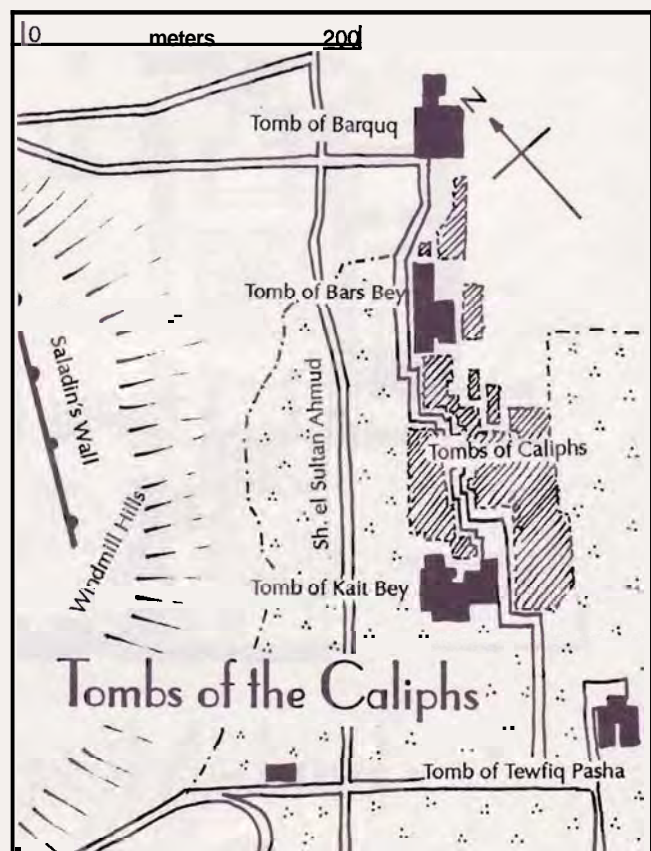

Scenario Hook: Sealed behind a false wall, a small room at the far end of the library in the Mosque of Kait Bey has not been raided. It contains Arabic texts and scrolls, including rare texts on the signs leading to the final apocalypse and rituals that can be performed by the faithful to ensure their acceptance into heaven. These rituals also provide immunity from the attacks of "demons and djinn", and can be used to obtain the jewel mentioned by Mustapha the silk merchant.

Tomb-Mosque & Convent of Sultan Barquq

This structure is partially ruined. The north dome was completed between 1400 and 1405 by Farag and Abd el- Aziz, Barquq's two sons, while the convent was finished by Farag in 1410. Each wall of the building is 240' long, and the building is large and dominating, even though totally abandoned and empty of all moveable fixtures. The top of the mosque is formed of a series of small spherical domes atop columns

decorated with tiled mosaic inscriptions from the Koran. At the rear of the large sahn el-gami is the entrance to the four-story monk's hall and a smaller hall. One of the two minarets was restored in 1900; the other is still in ruins.

TOMBS OF THE MAMLUKS

The Tombs of the Mamluks, or the South Cemetery, is in much worse repair than the North Cemetery. Few of the tombs have been restored, and many have been broken into in order to reuse the space inside for more burials.

Reached by tram 11 from Saladin Square, the most impressive of the remaining old structures are the Mosque and Mausoleum of Imam esh Shafi'i, the founder of one of the four orthodox rites of el-Islam, and the Hosh al-Basha (Mausoleum of the Pasha).

Mosque & Mausoleum of Imam esh Shafi'i

The mosque is dominated by a large modern minaret, lavished with decorations in the typical mamluk style. This minaret was built in the 1890's by Khedive Taufiq. A passage from the mosque leads underground to the tomb

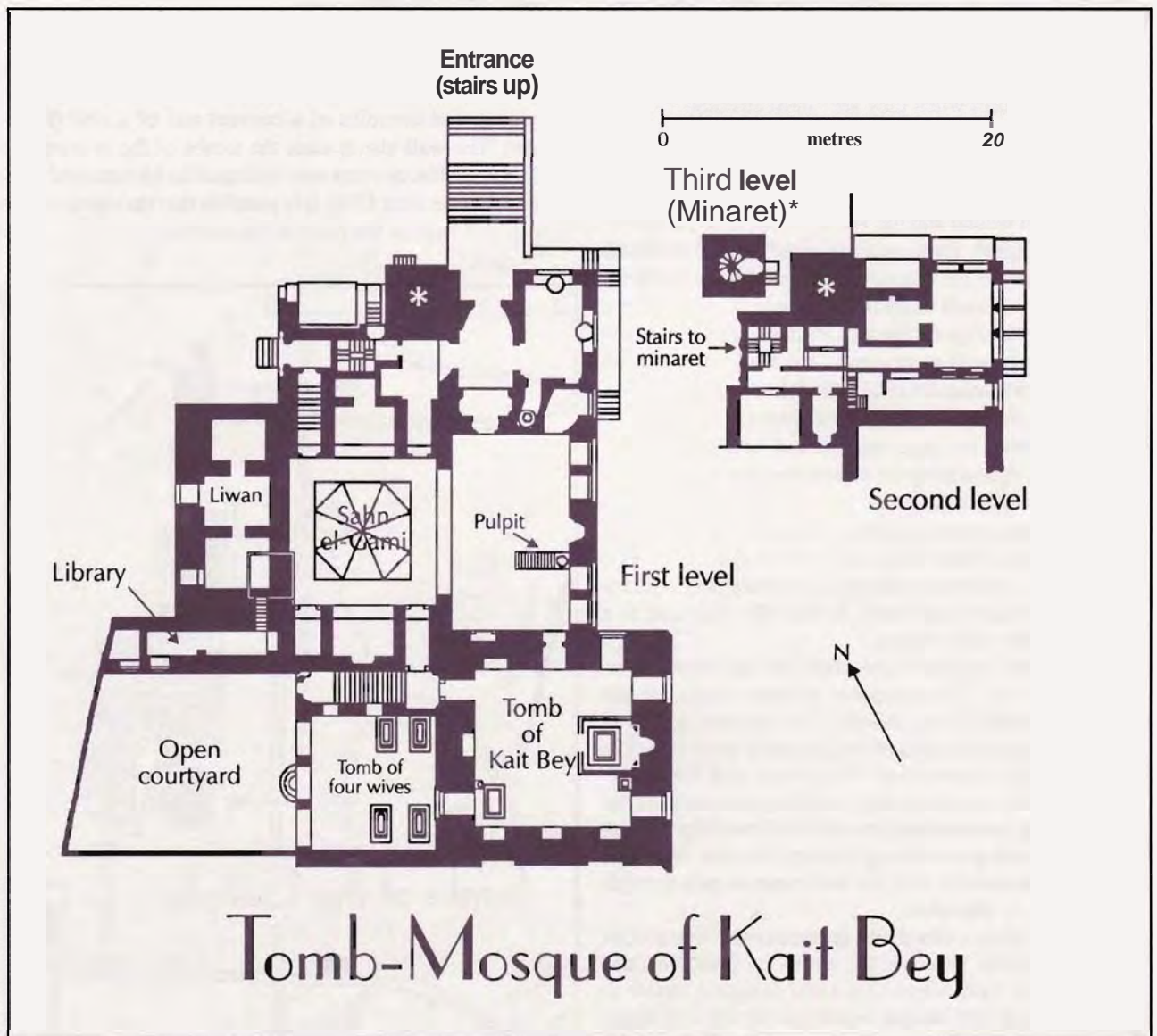

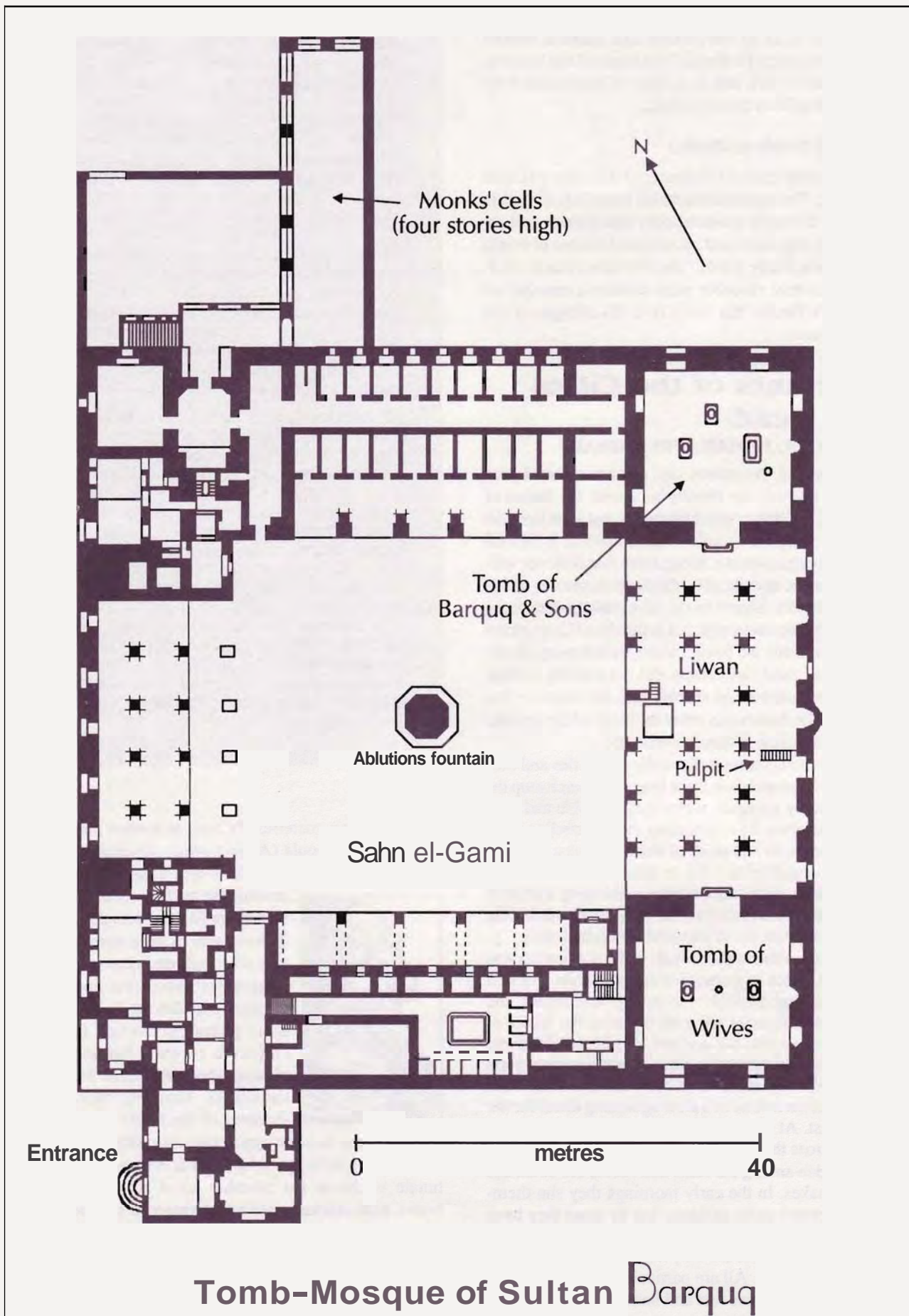

chambers, superbly decorated and domed. They were constructed in 1211 by the Sultana **Esh Shamsa**, mother of the **Ayubid** Sultan **El-Kamil**. The tomb of the Imam is closed to unbelievers, and is a place of pilgrimage with queues forming from dawn to dusk.

Mosque of Hosh al-Basha

This is the family **tomb** of Muhammed Ali, ruler of Cairo in the 1800's. The monuments inside are of white marble and are in a distinctly modern style. Inscriptions and ornamentations are gilded and **painted**, and the use of bright color appears initially gaudy. The individual tombs leading off the central chamber each contain a member of **Muhammed's** family. His tomb is in **his** mosque at the Citadel of Cairo.

Inhabitants of the Cities of the Dead

SCAVENGERS, HUMAN AND ANIMAL

Cairo is a **growing**, prosperous city, and has attracted poor people from all over **the country** to it with the dream of getting rich. They arrive with high hopes, but soon find that there is little work for unskilled **labor**, **housing** is beyond their **means**, beggars have a strong caste that does not welcome newcomers, and the only chance of survival is **squatting** outside the city. **Shanty** towns have built up outside the city walls to **the east** and south, and as the city of Cairo grows outwards even these are **being** moved further away. In the 1920's most of these newcomers eke out a living picking through the cemeteries and rubbish hills for anything that can be sold to the dealers that patrol the limits of the city, like **the vultures** that circle endlessly **overhead**.

Vultures are **everpresent** above the **cemeteries** and **rubbish** hills. At **dawn** and dusk these huge birds perch atop the tombs and nearby mosques, **where they** squabble and fight for favored positions. By **midmorning** they are circling overhead, their **keen** eyes and **sense of smell** searching for **fresh** kills and **unguarded** bodies. Up to fifty at a time **surround** **unburied** corpses, their raucous cries combining with their blood-spattered featherless necks as they argue over human entrails to make even the strongest of stomachs queasy.

Around the vultures the jackals **stalk**, waiting for opportunities to snatch an unguarded morsel or two. The size of small dogs and riddled with mange and rabies, the jackals of **the** cemeteries are a far cry from the image of the jackal-headed Set, the ancient lord of the dead and guardian of the underworld. Set's modern counterparts play their part in the removal of the dead, but a bite from one of them often results in a slow agonizing death for the unwary tourist. At night their harsh yipping and howling cries float across the hot still air of Cairo.

Also hidden **among** the **ruins** and rubble are countless venomous snakes. In the early mornings they sun themselves on exposed stone surfaces, but by noon they have **retreated** again into the coolness of **the** tombs and under ancient potsherds. Some are only mildly venomous, while others kill in seconds. All are particularly annoyed at being **disturbed** by careless feet and hands.

Scenario Hook: Tombs and graves are always a good source of Mythos adventures. From things as simple as being buried while still alive, to complex rituals conducted over the newly departed to reanimate them (or ensure they stay dead), cemeteries seem to attract a variety of weird and unusual people. Here can be found the madmen who collect body parts, the beggar who has a collection of spinal columns nailed to the walls of his hut, the ancient and withered woman surrounded by cats who cuts opium powder with the white powder of ground human bones, and the truly mystical who dedicate their lives to preventing those involved in occult practices from taking the hands and organs of the newly dead, patrolling the cemeteries by night armed with protective talismans and rituals of warding.

The vigilante guards have never quite stopped the occasional attempt at reanimation or resurrection, and cult members meet here on certain nights to recite their spells and bend the path of the future further towards their aims. Those who scavenge the cemeteries find a ready market for fresh body parts—hearts, hands, spleens, livers—among the cultists and mystic healers of Cairo, as well as among the rich and idle who dabble in things that they were never meant to know. There is also a market for extremely fresh, in fact live, bodies for rituals, and lost tourists in the wilderness of the old cemeteries may find themselves being hunted by those who know they can get a better price for a live body than a dead one.

GHULS

Present in the **cemeteries** of Cairo, as in **other** places of the dead, are the **ghouls** (Arabic: *ghul*). At **dusk** they **creep** from their **hiding** places, **their eyes** gleaming in the **pale**



moonlight as they scan their surroundings for **new** burials to **devour**. **The** remains of **once-human** scavengers who perhaps became a little too hungry for their own good, these **hideous** parodies of **humanity** drag their **pustulent** bodies from one **corpse** to another, fighting for the choicest morsels **such as** the lips and the cheeks. **They** flee back into the **shadows of the tombs** when anyone **passes** By, the boldest **sometimes** venturing out to attack the unwary tourist by night. All that is found of the **unfortunate** victim in the morning are a few gnawed limb bones, each cracked open and the **marrow** scooped out by **grime-covered** fingernails grown **long** for just that purpose. Their extensive **tunnels** below the **cemeteries** connect directly with **the Dreamlands**, if those who **explore** them can survive the journey.

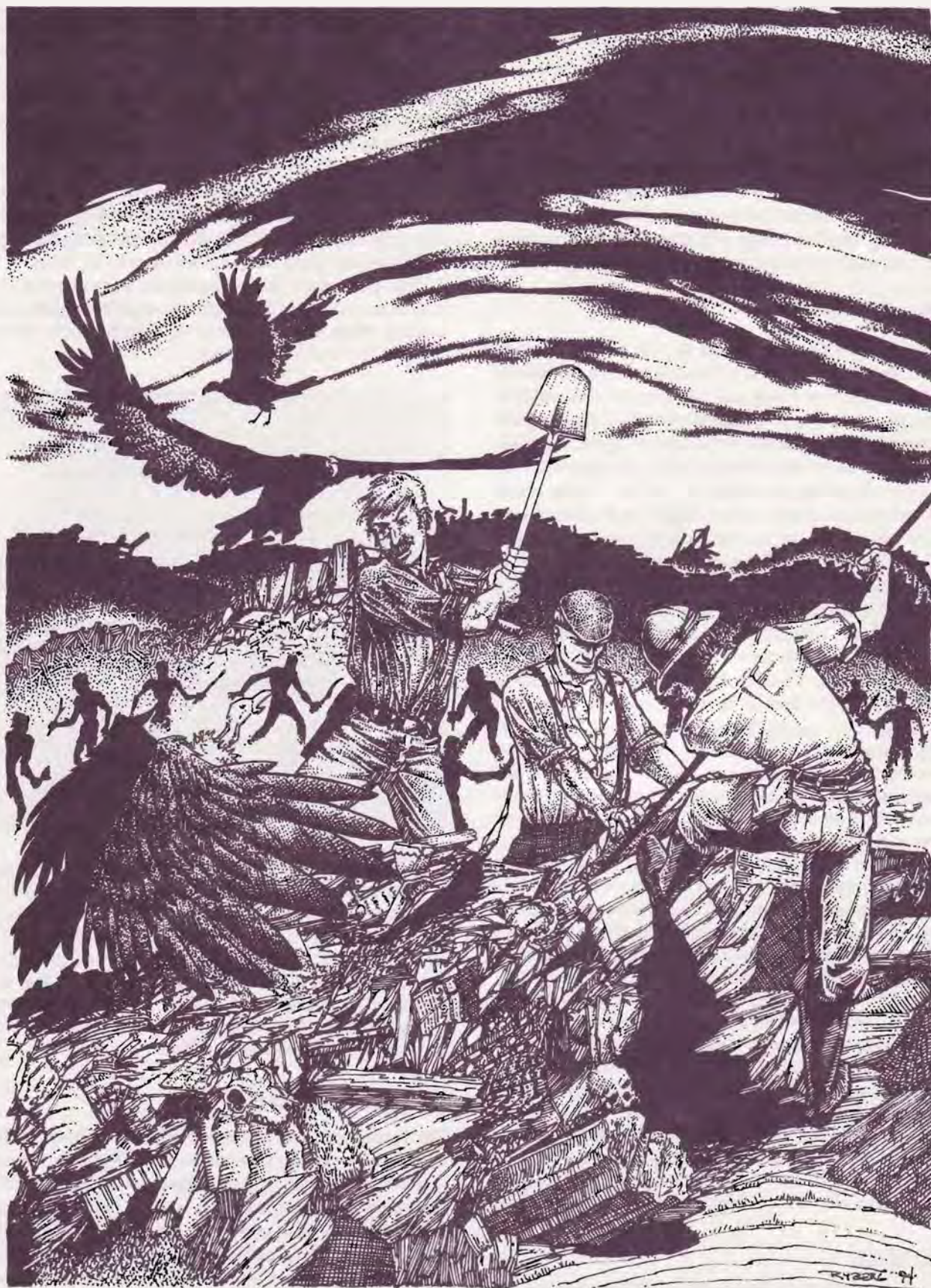

The Darker Side of Cairo

As in most large cities of the world, Cairo has its share of problems with the professional underworld. Thieves work the streets **and** the houses of the rich, drug-taking is a common pastime of the richest and poorest alike, and prostitution is the only way that women who have been thrown out by their husbands for real or imagined flaws can survive.

Theft

There are two types of thieves in Cairo: those who live there, and those who don't. The thieves who are natives of Cairo adhere to a very strict set of guidelines and consider themselves to be members of a profession or guild in their own right, similar to the thieves' guilds in medieval times. Their code is never to steal from those too poor to replace what has been taken, and never to cause physical harm unless in self defense. These are the thieves who work the tourists in the markets, the pickpockets and swindlers, and the professional beggars who simulate ghastly sores or crippled limbs with the assistance of a few everyday ointments and concealed bandages. These **are** the thieves who specialize in stealing from the houses of the wealthy, whether natives or travelers, the ones who took the pearl necklace or that book on occult practices that you just can't **find** the next time you look for it.

Objects are quickly passed on to fences in the markets, and **are** usually available for sale within a few days. Jewelry is always altered to make it unrecognizable; books and antiquities have usually been taken for specific purchasers who don't care where the items come from as long as they now have them.

Thieves from outside Cairo are less picky and strict about their thieving. These **are** the ones who will rob a starving woman of her last **millieme**, rape her children and then leave laughing. They know that they can always leave for another city if things get too hot. They **are** hated by the local thieves, and are frequently killed if caught by them. International jewel thieves occasionally work over the large hotels, booking in as tourists and leaving in the early hours of the morning with the contents of the safe. Surprisingly, none of the treasures of **Tutankhamun** are stolen during the 1920's; the security put in place by the Museum is considered too formidable.

Police do what they can to control theft; they mainly catch those who steal from the middle-class homes. The thieves who work the markets **are** too **poor** to bother with, and the ones who work the rich **are** too smart to get caught.

Drugs

Throughout the early years of the 1920's all drugs are legal in Cairo. Hashish, laudanum, opium and its deriva-

tives cocaine and heroin can be purchased from any pharmacy and **from** most stalls in any market. The going price for a kilogram of heroin in 1925 is 120 **£E**. Heroin is by far the drug of fashion in the **1920's**, with queues of high-class carriages outside pharmacies every night. At 10 **P.T.**—**20 P.T.** **per** shot, many of the gilded youth spend every night totally out of it. Some contractors pay their laborers in heroin. Its use by the poor is widespread; an epidemic of malaria in the poorer districts of Cairo in the early 1920's is spread by transmission of the parasite through the sharing of needles. Hashish is smoked in most of the city cafes, groups of six to ten men sharing the **goza** (hashish water pipe). This is rarely seen in the country.

The prevalence of drug use in the early twenties results in an underclass of addicts who exist by begging and stealing. Many survive by scavenging the trash cans at the backs of hotels and restaurants.

Scenario Hook: It's amazing what you can find written on notepaper thrown out of the richest hotels. A drug addict dying of malaria passes or sells a fragment of paper to one of the investigators. It contains a cryptic message regarding a meeting and summoning to be held at the Museum that night.

Scenario Hook: A woman in the suburb of Kahlifa sells large quantities of powdered heroin; she cuts it with the ground up skulls of mamluks taken from the nearby cemetery. She also finds many other things when searching for bones through the ruined tombs. These she sells to her sources in the market.

The Egyptian government makes the selling of drugs of addiction illegal at the end of 1925. The penalty for being caught is five years imprisonment, **and/or** a **1000 £E** fine. This results in the market price of heroin immediately jumping to **300 £E** per kilogram. The Chief of Police, Russell Pasha, also begins a crackdown on the importers and traffickers, with nightly raids on warehouses by the docks in 1928. His men travel the markets daily, and arrests **are** frequent and sudden.

Prostitution

The women, girls, and boys who work the streets and brothels of Cairo **are** largely poor and desperate. Egyptian women **—and their** daughters and sons—have been driven into prostitution by no support **from** their families, and by the Mohammedan laws that make it easy for a **man** to divorce his wife and almost impossible for a divorced woman to re-**marry**. Foreign women, mainly **from** other Mediterranean countries, **are** attracted by the profits to be made.



The main district is in the northeastern **Ezbekiya**, between **Shepherd's** and the Nile, and along the **Muski** by night. It is **described** by a **traveler** as being "like strolling through a **zoo** with painted harlots sitting like **beasts** of prey behind the **iron** grilles of their **ground** floor brothels, while a noisy crowd of natives, soldiers and tourists **make** their way along **the** narrow lanes."

All tastes **can** be catered to; those poor enough to become **street** prostitutes in Cairo **are** rarely picky about what happens next. There are also families for whom prostitution is a tradition. The fathers go and solicit **the** clients, who **are** then brought back to their daughters and sons; the **mothers** look fifty **or** more when they are still in their late twenties. Their business is generally referred to as the "one shilling trade" by most locals.

Higher class prostitutes and gigolos work the best hotels, posing as lonely travelers at first and later demanding money to prevent the inevitable scandal. Some have also been recruited to spy on diplomats **from** foreign embassies, and these glamorous **and** beautiful women hang off the arms of their targets at the hotel balls.

Slums

The dangerous part of Cairo is the slum area of **the** northeastern Abbassiya, north of the medieval quarter and outside the old city walls. This district is one **that** no foreigner should walk through **unescorted** if he wishes to walk **again**. The people who live here **are** rumored to eat **human** flesh in **preference** to the rats that **are** their staple diet. Police rarely go here, and most other locals shun this district.

A smaller slum and rough district is the northeastern **Ezbekiya**, also **known as** the Wasa, a "little island of ruffianism in the heart of Cairo." The same streets that house the flesh trade by night are dangerous to walk by day, and most tourists are advised to stick to the main roads when traveling through this district.

Scenario Hook: The "King of the Wasa", a huge fat Nubian who controls most of the organized prostitution and drug trade in Cairo, can be found each day sitting outside one of his palatial houses in the Sharia Abd el-Khalig. He sits cross-legged on a bench, dressed as a woman, and veiled with the finest white silks. This ebony idol is worshiped by those he employs, who flock around him like wasps around a honey jar. He occasionally holds out a bejeweled hand to passersby whom he recognizes. Those whom he sees who particularly take his fancy are invited into his house for a cool drink or to inspect his fine collection of ancient artifacts; many never reappear. He controls and supplies the white slave trade, and provides cults with young white women for sacrificial rites. The police have tried to stop him but have yet to succeed; many of the top judges are in his debt.

Excursions from Cairo

"The next morning we visited the Pyramids Down the shore road we drove, between great rows of lebbakhs and past the vast Zoological Gardens to the suburb of Gizeh"

Giza

We saw silhouetted against its vermeil holocaust the black outlines of the Pyramids of Gizeh Then we knew that we were done with Saracen Cairo, and that we must taste the deeper mysteries of primal Egypt—the black Kem of Re and Amen, Isis and Osiris. — "Trapped with the Pharaohs"

If the traveler to Egypt **knows** of nothing else, he has heard of the famed Pyramids of Giza. These three huge **structures** were one of the seven wonders of the ancient world and still have an almost magnetic attraction, bringing visitors to Egypt from all over the globe.

Built by the pharaohs of the 4th and 5th Dynasties, they have survived over 4,500 years despite being constantly looted for their tomb goods, and raided for stone to build many of the medieval and modern structures in nearby Cairo. Originally, the pyramids at Giza were covered with highly polished white limestone, and capped with gold leaf; they gleamed brightly in the ceaseless sun of summer. This facade was the first thing to go, and now only a tiny fragment of marble cladding remains at the very apex of the Pyramid of Chephren (the middle of the three monoliths).

Getting There

Giza can be reached easily from Cairo by trams No. 14 or 15, or by motor bus, and the road to the pyramids is in excellent condition by the end of the 1920's. The Mena House Hotel, at the end of the No. 14 tramway, provides refreshments to tourists and allows them to escape from the press of guides and camel masters exhorting tourists to allow them to reveal the wonders of the ancients.

Camel and donkey tours are by far the most common way to view the area, and it is advised that travelers wear clothing appropriate for walking and riding. Ladies intending to ascend the pyramids should dress as they would for mountain climbing. Some **days** can be quite **windy**; the driving sand blowing in from the desert beyond the pyramids can be dangerous to those unused to dry conditions. Sunglasses are highly recommended.

Tickets for inspection tours of the pyramids are sold in a small office at the upper end of the same street as the Mena House Hotel. The standard expedition—ascend of the Great Pyramid, visit to its **interior**, and guided tour of the Sphinx and the other **monuments**—costs 20 P.T.

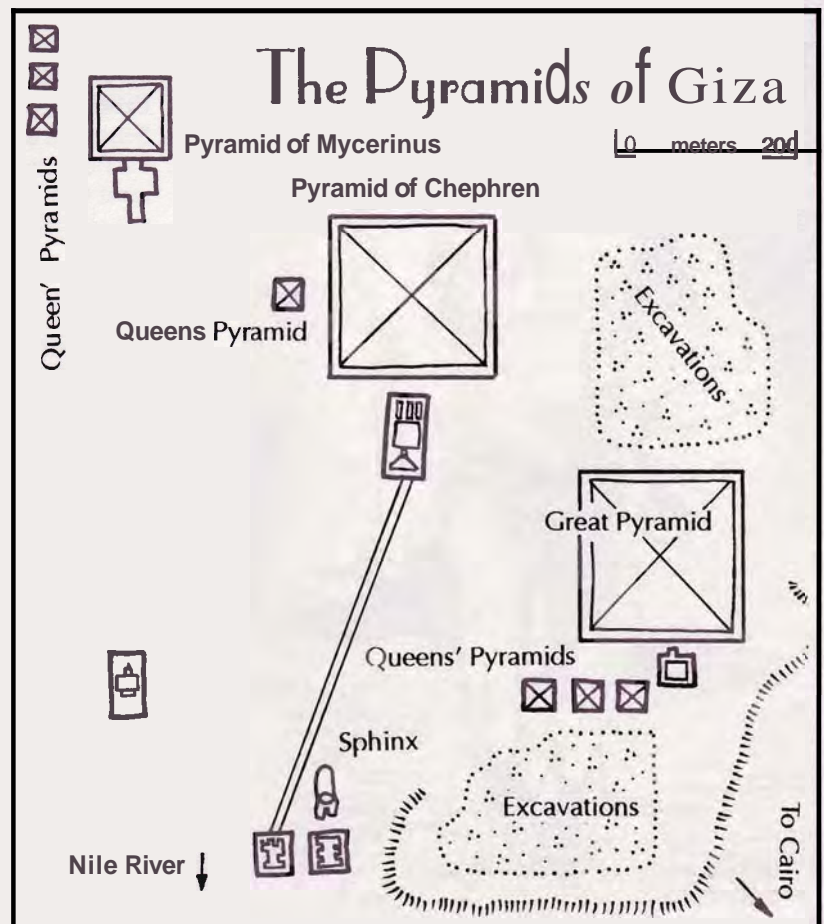

A Bedouin from the village at the **tran** terminus, Ahmed has spent most of his life showing visitors around the pyramids. His English is good, and he **knows** the best ways to climb all of the pyramids (+20% to Climb rolls). He is proud of his profession and tries to learn all he can from those excavating the sites around the pyramids. He is a regular visitor to the dig sites, and his older brother **Ali** is a foreman at the current dig.



AHMED, Bedouin Guide, age 28

STR 14 CON10 SIZ 14 INT 12 POW10
DEX 13 APP 9 EDU 10 SAN 50 HP 12

Damage Bonus: +1d4

Weapons: Knife 60%, damage 1d4 + 2 + 1d4

Skills: Bargain 55%. Fast Talk 60%, History (Pyramids)30%;

Languages: Arabic 50%, English 30%. French 20%. German 35%

Excavations

The public is not admitted to areas being excavated. The main expedition is that of the Harvard-Boston Expedition and the Vienna Academy of Sciences, who are conducting a joint excavation to the east of the Great Pyramid. Led by Dr. George A. Reisner of Harvard, their expedition is uncovering the tombs and temples built by **Cheops** for his household and servants, as well as the funerary temples used in the preparation of his body for mummification and

the **afterlife**. A large number of embalming tools and artifacts have been found, and **all finds are being** catalogued at the site before shipment to the Egyptian Museum.

Travel guides of the 1920's mention that detailed wall paintings and hieroglyphics in the pyramid of **Cheops** contain the full text of the Book of the Dead as well as all spells required for the resurrection of the Pharaoh in the afterlife. Inspection of the pyramid finds no trace of any text, and inquiries to staff at the universities result in blank stares and a lecture on how the text is thought to be Middle Empire in origin, not earlier. To find the full text, investigators will need to travel to the Valley of the Kings and inspect the papyri recovered there. Inquiries of pyramid guides, however, result in stories of how the text was there in **the times** of their fathers and grandfathers, and how it simply vanished one night during a fierce **sandstorm**.

The Pyramids

Each pyramid is the burial tomb of a pharaoh and his wives (it is now generally accepted that what were thought in the 1920's to be wives' tombs were really false tombs set up as decoys for grave robbers). The rest of their servants and household were buried in smaller tombs clustering around the foot of each pyramid. The sloping passages within the pyramids leading to the tombs **are** regularly traversed by tourists; **the** smoke from the burning torches carried by their guides has stained the walls and the ceilings, in some cases obscuring the bright wall paintings.

The three pyramids at Giza were built at different times; each needed the labor of thousands of men to complete. Contrary to popular belief, they were not slaves, but **free** men employed for the duration of their lives in the construction of these timeless monuments to their God

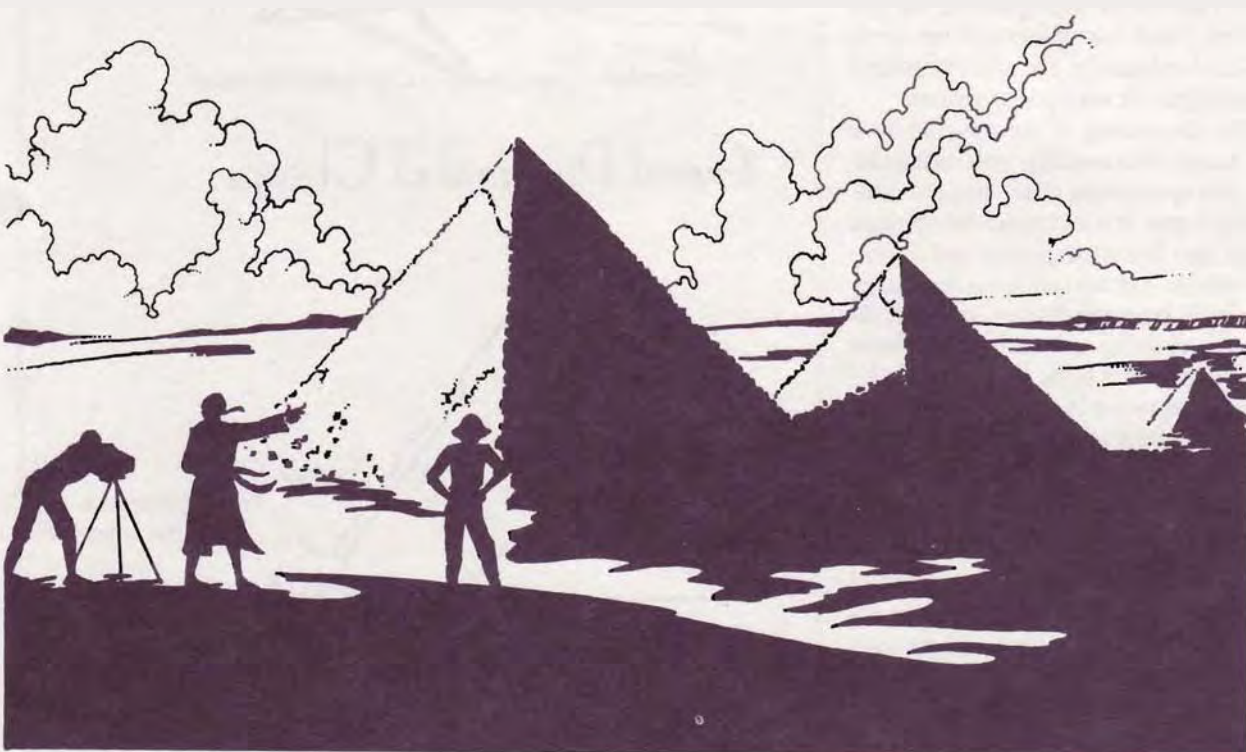

Kings. Huge limestone blocks were quarried further up the Nile, loaded onto barges and floated downriver to Giza. The stones were trimmed to shape, and then moved into place using wooden rollers and ropes to man-haul them up huge, temporary earthen ramps that gradually spiraled their way to the pyramid top. Once the last stone was placed the ramps were removed, and the true shape of the perfect pyramid was revealed to all.

THE GREAT PYRAMID

Largest of the three, the Pyramid of Cheops (or the Great Pyramid) was built in 2690 B.C. and stands **137** meters high. It is estimated that over **2.3** million limestone blocks were used in its construction, weighing more than six million tons in total. The passageways inside lead to the tomb chambers of the Queen and two others, neither one of which is the true King's chamber. There is still speculation as to where the chamber of King Cheops (**Khufu**) actually is, with many archaeologists searching for it over the years.

The entrance in the third tier of stones on the north side of the pyramid was made by Arab treasure hunters about two thousand years ago and is below the original entrance, higher up the pyramid in the thirteenth tier. The more modern passage extends **darkly** into the interior, its stairs making the descent inside easier but no less claustrophobic for some. After 60 meters the great hall is entered; at the far end a small horizontal passage leads to a ladder that is climbed to enter the King's Chamber above. This chamber contains only a badly mutilated granite sarcophagus, the inscriptions faded beyond reading, and the lid of which had disappeared before **1799**. Two air shafts rise out of this chamber, far too small to climb but ensuring fresh air is circulated constantly. The other chambers and passages are not open to visitors.

The dimensions of the pyramid have been keenly measured by both archaeologists and spiritualists alike. The spiritualists claim that it is a channel for spiritual energy, and that its alignment and dimensions enable it to tap and focus the energy emanating from the hidden spiritual dimension. A group of these people have taken up residence at the Mena House Hotel and hold secret ceremonies inside the Great Pyramid during the night of every full moon.

To the Top

Climbing the outside of the pyramid takes about twenty minutes and it is advised to follow a guide; two or three tourists fall to their deaths each year while climbing. Each of the blocks that forms the steps to the top is one meter high, and the

inexperienced climber requires pushing from below as well as pulling from above. After all, that is why you have the guides on **hand**

The space at the top of the pyramid is about 12 meters square, with plenty of room for all in the climbing party to stand and enjoy the **magnificent** view of the Nile Valley and Cairo (before contemplating the strenuous climb down). To the west, south, and northwest, yellow-brown tracts of sand are interspersed with barren cliffs. On the bare plateau of rock in **front** stand the other pyramids and the Sphinx, with **the** layout of the burial ground clearly visible. To the south rise the smaller pyramids of **Saqqara**, Abusir, and Dashur, while to the north are the green and fertile lands of the Nile and the vast palm groves of Kir-dasa. To the east, across the river gleaming brilliant blue in the bright sunlight, the buildings of Cairo squat upon the landscape, punctuated only by the minarets of the mosques and **the** citadel.

THE PYRAMID OF CHEPHREN

The Pyramid of Chephren, southwest of the Great Pyramid, stands **136** meters high and was built in 2660 B.C. The tunnels leading to the single burial chamber are cramped and claustrophobic. Many are too **narrow** to eas-

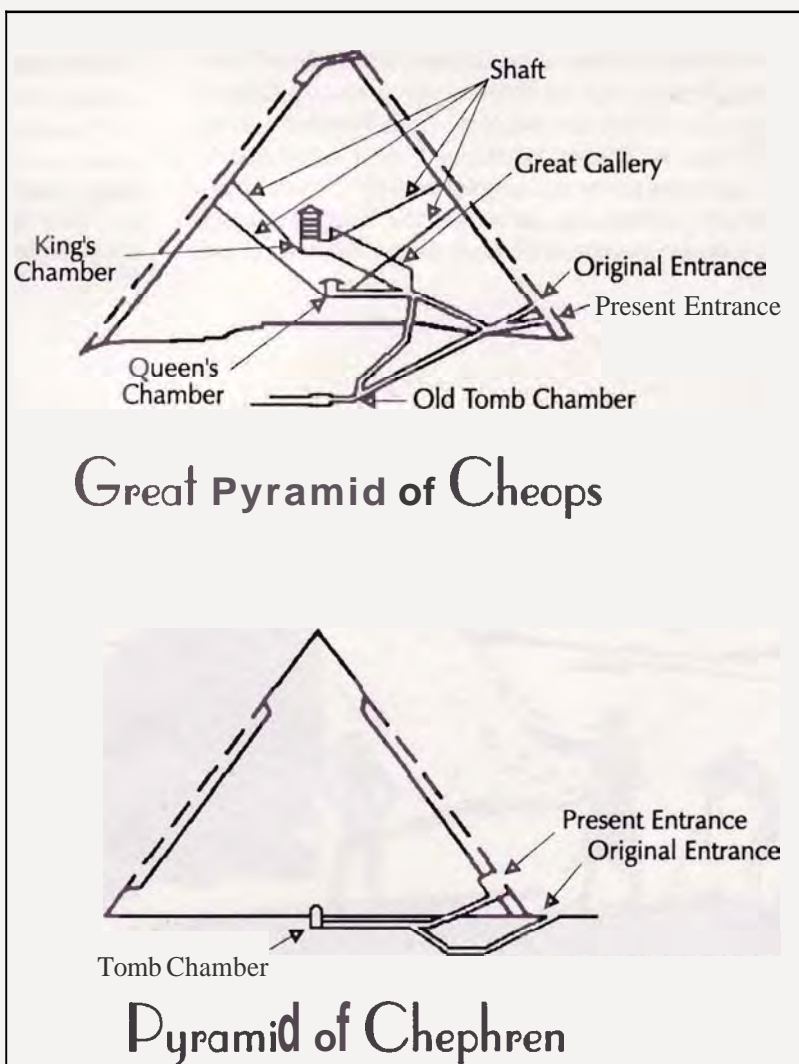

ily turn around in. **Two** passages lead into the north side of the pyramid; one is blocked, the other open to invited tourists only. **The** passage descends into the pyramid for 40 meters, and then opens out into the completely looted tomb chamber. The granite sarcophagus was found broken and empty in 1818. The second passage leads to a tomb chamber, below the base of the pyramid, which was never used.

Chephren (Khefre), the son of Cheops, also built a large mortuary complex to the east, which includes the famed Sphinx. A causeway runs **from** this complex **to** ward the Nile River and ends where the ancient course of the Nile ran.

THE PYRAMID OF MYCERINUS

The Pyramid of **Mycerinus (Menkewre)** is the smallest of the three pyramids at **62** meters, and was built between **2525** and **2500 B.C.** The interior of the pyramid is difficult to enter, with the entrance through a very narrow passage on the north face. A steeply sloping (unstepped) passage descends to below ground level and leads to an **antechamber**. A series of trap doors and smaller chambers leads to a horizontal shaft, at the bottom of which is the tomb chamber. The sarcophagus found here in 1838 was richly decorated and made of basalt. **The** lid was open; the fragments of mummy and the coffin found within it are now in the British **Museum**. **The** ship carrying the sarcophagus itself to England sank off the coast of Spain.

The Sphinx

Presently we descended toward the Sphinx, and sat silent beneath the spell of those terrible unseeing eyes. ... It was then that the smile of the Sphinx vaguely displeased us, and made us wonder about the legends of subterranean passages beneath the monstrous creature, leading down, down, to depths none might dare hint at — Trapped with the Pharaohs

The guardian of the pyramid of **Chephren's** funerary enclosure, the Sphinx is buried up to its neck and back in sand until **1925-1926**, when it is excavated to its base by E. **Baraize** on behalf of the Egyptian Department of Antiquities. Several pieces of **the** statue that had fallen off into the sand are fixed back on with cement and the head-dress is supported by iron rods, but no further reconstruction of missing parts is attempted.

The Sphinx was carved during the construction of the Pyramid of Chephren, from a massive limestone outcropping that occurred naturally at the site. It is rumored that its nose was shot off by one of Napoleon's cannons in 1799. Between its paws is an open temple, enclosed by two partitions connected by a narrow passageway. In the middle of the passage is the remains of a statue of a lion facing the Sphinx.

Scenario Hook: Beneath the Sphinx is a vast network of tunnels and rooms, ending in a vast ceremonial chamber directly below the sphinx itself. This chamber is used by the Brotherhood of the Black Pharaoh and the Children of the Sphinx. Here they pay homage to the terrible and blasphemous gods of the Mythos, older than Egypt itself. The tunnels have a number of hidden entrances, some among the temples around the pyramids. One concealed entrance may be found in the grotto in the Zoological Gardens by the Nile.

Scenario Hook: The whole complex around the pyramids and Sphinx is riddled with the tombs of minor officials, queens, and many small temples. Some have been excavated and mapped; many have not yet been discovered. Two large roofed pits at the foot of the Pyramid of Cheops are discovered in the 1950's: One reveals a life-sized funerary boat, and the other remains sealed and has only recently been examined by optical fiber video to confirm that it holds a second boat. In the 1920's, and even perhaps in modern times, the possibilities for archaeological adventure and the discovery of tombs to Mythos gods are considerable.

Up the Nile

If time allows, most visitors to Cairo take a trip up the Nile River to visit the many sites of ancient Egypt. These include the temples at Tel **el-Amarna** (the city of the heretic Pharaoh **Akhenaten**), **the area** around **Luxor (Thebes, Karnak, and the Valley of the Kings)**, and the first cataract and luxury hotels at **Aswan**.

Those with enough time to spare take a leisurely steamer cruise up the Nile, stopping each **day** at a site of interest and sleeping each night in a luxurious cabin on the steamer. Those with less **time** take the train, breaking the journey to inspect sites along the way and sleeping overnight at cheaper hotels near the stations.

Both travel methods can be organized well in advance through Thomas Cook's travel agencies, or by pursers on board ship before arriving in Egypt.

Traveling up the Nile

A CRUISE UP THE NILE

Steamers to Upper Egypt are mainly operated by **two** companies. Thomas Cook & Son have seven tourist steamers on the Nile: **Sudan** (80 berths), **Arabia** (80),

Egypt (80), *Thebes* (48), *Rosetta* (60), *Damietta* (60), and *Delta* (44). One steamer departs from the docks above the Kasr el-Nil Bridge every week during the tourist season, with extra steamers sailing when the demand is high or when booked by special groups.

Round trip fares (Cairo-Aswan-Cairo) are 70f for a single berth cabin and bath, or 120£ per person for a double berth state cabin with balcony. All expeditions, guides and meals are included in the fare; drinks are extra.

The Anglo-American Nile & Tourist Company has five tourist steamers: *Victoria* (72 berths), *Britannia* (72), *Puritan* (72), *Nubia* (54), and *Mayflower* (54). One steamer departs from the docks at Roda Bridge (Kasr el-Aini Bridge) each week during the tourist season.

Round trip fares are 70£ for a single berth cabin, and 200£ for a double berth deluxe stateroom. Each steamer has its own doctor and pharmacy, and is able to cope with most emergencies that occur during trips and expeditions.

Both companies offer the same itinerary, the voyage taking twenty to twenty-one days with visits to temples or other ruins along the route every day. Perhaps of more interest than the artifacts, though, are the other passengers on the steamers. They are always a mixture of all types,

from the earnest students of archaeology and history to the idle rich bored with the night life of Cairo, from the highly placed government officials entertaining visitors to Egypt to the nearly bankrupt gamblers attempting to make their fortune at the roulette wheels each night. There are always gigolos and prostitutes on board; these are the wealthier of their type and they spend each winter sailing up and down the Nile for the entertainment of the other passengers and for the benefit of their own bank balances.

Scenario Hook: A group booking on the steamer on which the investigators are traveling has been made by a Mythos cult (10-15 people) who are traveling at leisure to conduct a rite at the main temple at Karnak "when the stars are right." They are an odd collection of people from all walks of life and have not met each other in person before embarking on the cruise, having communicated previously only by letters and wires. There is always a chance that investigators may get mistaken for one of their group.

Typical Daily Cruise Stops

- Day 1: Depart Cairo 10:00 a.m., visit Memphis and Saqqara
- Day 2: To Minya
- Day 3: To Benihasan, visit tombs of Ameni-em-Het and Knemhotep
- Day 4: To Asyut, visit town
- Day 5: To Girga
- Day 6: Past Balyana and Abydos to Dendera
- Day 7: Temple of Dendera, steam to Luxor
- Day 8: Luxor, visit Kamak and Temple of Luxor
- Day 9: Luxor, visit Valley of Kings and Deir el Bahari
- Day 10: Luxor, visit Ramesseum, Deir el-Medina, Medinet Habu, and Tombs of the Queens
- Day 11: To Esna, visit temple, to Edfu, visit temple
- Day 12: Past Gebel Silsila to Kom Ombo and Aswan
- Day 13: Aswan, ride to granite quarries and to Shellal, by boat to Philae and Nile Dam, by donkey to Aswan
- Day 14: Aswan, to Elephantine Island and bazaars of Aswan
- Day 15: Begin return voyage, to Luxor
- Day 16: Revisit Kamak or visit Western Thebes, to Nag Hammadi
- Day 17: To Balyana, visit Abydos
- Day 18: To Asyut
- Day 19: To Beni Suf
- Day 20: Arrive in Cairo early evening or on the following morning (passengers may disembark after breakfast)

UP THE NILE BY TRAIN

Trains depart from the Central Cairo Railway Station twice daily, express trains taking 12-1/2-13-1/2 hours from Cairo to Luxor, 17 hours from Cairo to Aswan, and 4-1/2 hours from Luxor to Aswan. Fares to Aswan are first class 3 £E 88-1/2 P.T., second class 2 £E 54-1/2 P.T., sleeping car supplement 1 £E 25 P.T. Travelers are advised to take their own food; the buffet car is crowded and no stops are made for meals.

The railway follows the Nile Valley, and most of the major sites of interest can be seen from the trains as they pass. Travelers can alight at any station and rejoin any later train if they wish to inspect the ruins in more detail. Accommodations at the small towns along the line are basic and far more expensive than they should be.

UP THE NILE BY MOTOR CAR

This is not possible. Even at the end of the 1920's the roads are appalling, and many are impassable to wheeled vehicles for most of the year. Short stretches of usable road link the railway stations with sites of archaeological interest, but between sites the railway and river are the main transport routes. Camel travel up the Nile Valley is possible but extremely slow, and prices and availability of camels are not always in the traveler's favor.

UP THE NILE BY FELUCCA

Sailing up the Nile in the typical lateen-rigged felucca is an adventure in itself. The journey to Aswan takes fifteen days, and the close proximity to the water makes the passenger very conscious of the largeness of the crocodiles and hippopotami that inhabit the brown waters. The boat is taken ashore each night, and accommodations are

bargained for in the houses of those who live on the river banks (often relatives of the boat master). Food and accommodations are Egyptian style; no concessions are made for Western taste or comfort. The round trip (Cairo-Aswan-Cairo) will cost around 1 £E, but it brings the investigator closer to the real Egypt.

Tel el-Amarna

City of the "heretic" pharaoh Akhenaten (or Amenhotep IV), the name of the city is a Bedouin one; its original name, Akhetaten, is never spoken by the Bedouin, and is only found on stele found around the city's perimeter during excavations in the 19th century. The main tombs and sites are a short donkey ride from the Nile River. Train travelers alight at the station of **Deir Mawas**—on the west bank of the Nile, 188 miles upriver from Cairo. After a twenty-minute donkey ride they reach the river, where a ferry is provided for tourists to cross (5 P.T.). The cost of hiring a donkey for the duration of the visit is between 15 and 20 P.T. (donkey hire is included in river cruises). The ruins of the city are

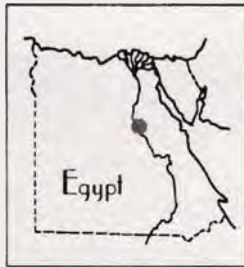

on both banks of the Nile, but those on the east bank have been excavated and are the most interesting.

Akhenaten

The ruler of Egypt between 1411 and 1375 B.C., this pharaoh of the 18th Dynasty struck out against the old gods and priests of Egypt by establishing a new religion. He banished the previous pantheon of gods and declared that the only true god was Aten, the sun. He moved from the previous royal capital at Thebes to the site of El-Amarna and constructed a vast city. The style of art he used, the Amarna style, was more realistic and natural than the stylized portrayals in palaces and temples, and he was an accomplished poet and speech writer. Many of his poems still survive today. In order to establish the sun god as the only god, the names of all the previous gods were destroyed where they were found, and the punishment for worshipping the old gods was death.

With his wife, the famed and beautiful Nefertiti, he ruled Egypt until his death in 1375 B.C. On his death the priests of all of the old gods—who had spent the previous thirty-six years paying lip service to Akhenaten's chosen one god—began to fight to establish theirs as the supreme gods of Egypt. One of his successors was the boy-king Tutankhamun, whose tomb treasures astound the world when they are uncovered in December 1922.

There are some who say that Akhenaten was truly mad, the result of too many generations of brother-sister marriages in the royal family (for only a god can marry another god). Others claim him to be a visionary ahead of his time.

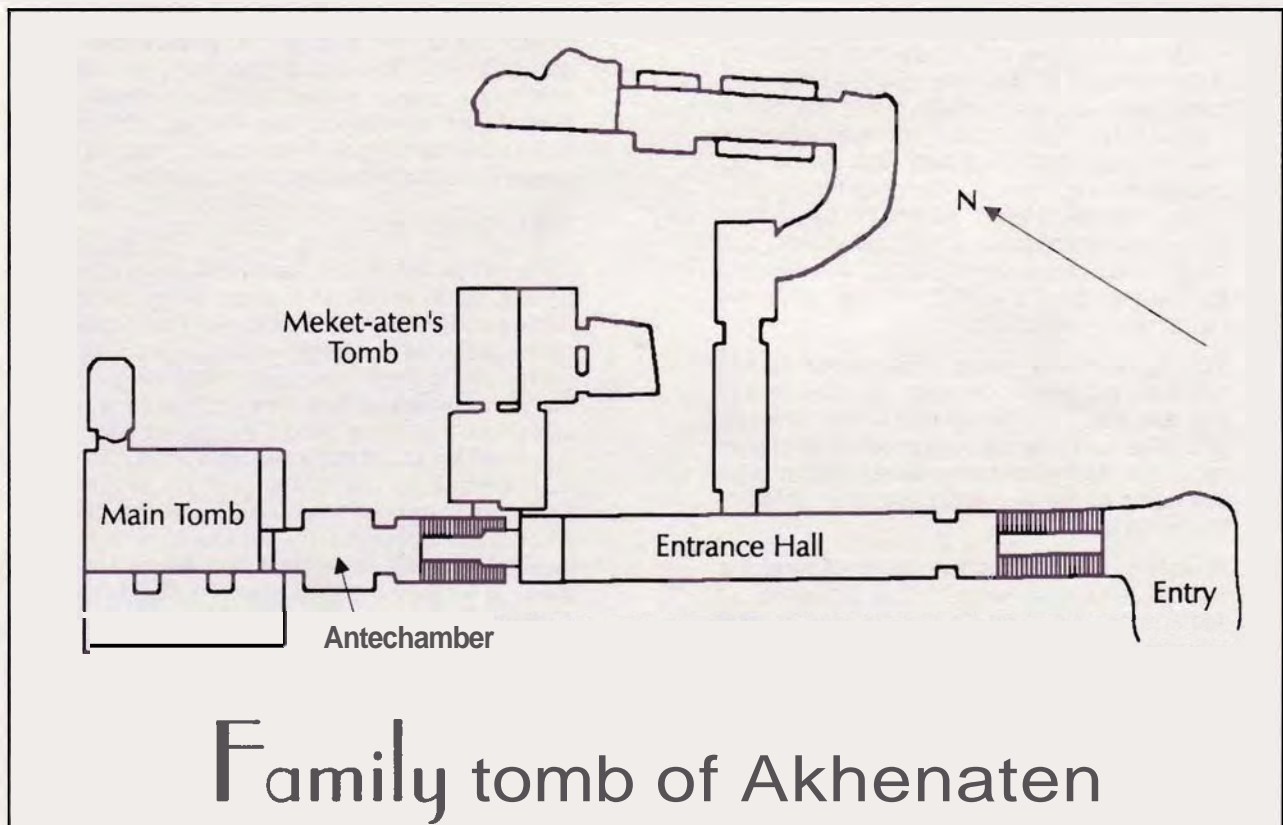

Scenario Hook: Some claim that the sun he so readily worshiped was in fact the representation of an older, more primitive god. That the halo of rays ending in hands offering items to Akhenaten represent the intervention of a messenger of a circle of ancient, blasphemous gods. That at the center of the circle claimed to represent the sun is a vast fiery mouth that would have devoured the world if the old and true gods of Egypt had not been restored.

Scenario Hook: The excavators are beginning a new phase just over the mountains, in a valley to the east of the main city site. This is the fabled valley of Hadoth where the catacombs of Nephren-Ka, high priest to Akhenaten (and high priest of Nyarlathotep), lie sealed below the rubble and sand of over 3000 years. Nephren-Ka originally lived in the 16th Dynasty; he was a priest who, through the use of evil magics, overthrew and replaced the pharaoh. On his death he was mummified and placed in a tomb near Thebes. His tomb and mummy were discovered by the young Akhenaten, who performed magical rituals and awakened the dead sorcerer. Nephren-Ka became the close friend and chief advisor to the young pharaoh.

Nephren-Ka converted Akhenaten from worshipping the old gods into honoring Azathoth—an Outer God—and the messenger of the ancient gods, the Black Pharaoh Nyarlathotep. All representations of the sun god Aten are a fiery disk surrounded by rays ending in hands offering or taking gifts. These actually depict Azathoth, its chaotic mass resembling the sun, and the intervention of the messenger Nyarlathotep represented by the hands at the ends of the fiery rays (tentacles) of Azathoth.

To make these gods acceptable to his subjects, Akhenaten chose to use the name of the sun, Aten, as the symbol of the new one god. The sun was also appropriate as it also represented the fiery destruction and cleansing of the old world, and the rebirth of the world to come.

Unable to bring about the resurrection of the Black Pharaoh within the lifetime of Akhenaten, Nephren-Ka constructed a vast labyrinth of catacombs and tombs in the valley of Hadoth, beyond the city. The pattern of this labyrinth is designed to focus energy. Inscriptions on the walls of the tombs tell of the power of the mysterious and unnamed "Black Pharaoh", and have been interpreted by

The Ruins

The tombs here are in two groups, the North and the South Tombs. The keeper of the North Tombs can be found in the village of Et Tel, on the bank of the Nile; the keeper of the South Tombs lives nearby at **Hagg Qandil**. Both are middle-aged Arabs, and are only too happy to open the tombs for visitors, especially when presented with an appropriate amount of baksheesh.

The ruins are extensive, but many of the finest artifacts and statues have been defaced. The best examples of the art of the period are in the Egyptian Museum, but smaller pieces are being uncovered by the current excavations all the time. The delicate beauty of intact portraits and statues is breathtaking, the elongated foreheads and

most of the archaeologists as telling of a Nubian relative of Akhenaten. They are of course wrong.

Opening the Tombs

Opening these tombs and the labyrinthine passages that make up the catacomb complex activates the mystic wards set in place millennia before, wards required to strengthen and resurrect the Black Pharaoh Nyarlathotep.

For each hour that a person is within the catacombs, he loses 1 MP. For every 10 MP he loses over time, 1 point of permanent POW is also lost. This feels to the victim like creeping lethargy, and is easily attributed to the poor air circulation in the tunnel complex. When 1000 MP and 50 POW have been accumulated within the catacombs (this may take a few days or weeks, but the numbers of local Arabs working at the site as laborers makes this easier and faster than it seems) a tremendous storm begins.

The Unholy Storm

Wind whips the desert sand until it punches tiny holes in tents and strips paint off all surfaces. The day turns to darkest night and green forks of lightning emanate from the center of the tomb complex. At the height of the storm, when all feel sure that they will be killed, an explosion rends the ruins, and a figure strides out of the wreckage. A tall, black man garbed in the clothing of an ancient Egyptian pharaoh, he walks toward the witnesses. Any who try to touch him are swatted aside as if they were flies, taking 1d10 damage as they fall. The Black Pharaoh (see *Call of Cthulhu* 5th edition, page 116 for statistics) continues past them and on into the desert beyond the dig. His footprints are obliterated by the storm that rages on for another hour, but the direction he was traveling in is that of Cairo.

skulls of the Pharaoh, his wife and his daughters appearing strange but not ugly.

The palace of Akhenaten, fifteen minutes' ride from the river, is a shell with little to see. Uncovered between 1891 and 1892, it was **destroyed** by looters in 1912. East of the palace are the royal archives; stone and clay tablets found here containing the poems and prayers of **Akhenaten** to his family and god **are** in the Egyptian Museum.

Surrounding the palace **are** the houses of the court **officials**, sculptors, and **Ramose**, the general of the **army**. The Great Temple to the north of these ruins exists only as a floor amid the sand; no traces of the walls or their carvings remain.

Scenario Hook: Several of Akhenaten's stone and clay tablets are kept in the four hidden rooms at the Egyptian Museum. They contain invocations to the "Black Pharaoh", and bear the cartouches of both Akhenaten and his high priest of Aten, Nephren-Ka.

North Tombs

Three quarters of an **hour** to the **north** of the palace are the North Tombs. This complex contains:

The tombs of Huya and **Meri-re**, superintendents of the royal harem. Decorations within these tombs contain scenes of royal family life; most of the faces of people in them have been obliterated.

The tomb of the pharaoh's physician, **Pentu**, which is badly damaged. **Pentu's tomb** contains many scenes of the **king** and queen praying to the sun disk, represented as a circle surrounded by many rays, each ending in a messenger's hand.

South Tombs

The South Tombs, one hour to the south among the natural rock **spires** of the **Gebel Abu Hasah**, **are** more extensive. **Eighteen** of them have been opened by the end of the **1920's**, and this is where most of the current excavation is taking place.

The tomb of Mahu, an officer of the royal police, is one of these. It contains scenes of the death and reincarnation of Mahu, showing how he returned to life after his death to continue serving the pharaoh. His reincarnation occurs when jagged lines shooting out from the sun disk penetrate his wrapped corpse and reanimate his body. He is then shown **kneeling** before the pharaoh and the-high priest in thanks.

The large family tomb of Akhenaten is entered down a flight of twenty steps (a smooth ramp between the two rows of steps is for the transportation of the sarcophagi) into the entrance hall. Beyond this a second flight of **six-**



teen steps leads down into the antechamber and **main** tomb chamber. This tomb has been completely looted and badly defaced; the remaining stucco paintings show scenes of court life, with the queen and princesses **worshipping** the sun disk. A second passage to the east of the second flight of stairs leads into the tomb of the princess **Meket-aten**. The wall paintings here are largely intact and show the royal family worshipping the sun disk, its rays (ending in human hands offering symbols of endless life) rising above the mountains to the east.

Excavations

Extensive excavations were carried out here prior to the Great War by the **German** Orient Society, and the majority of the main buildings have been excavated by the start of the 1920's. Since the war they have been continued by the Egypt Exploration Society, with new tombs discovered every year. Most of the best tombs have been discovered since 1913, and while many were looted in ancient times, the collections of artifacts being found and catalogued here are magnificent.

THE DESERTS BEYOND

In the rocky hills surrounding the plain of Tel **el-Amarna** are many of the quarries used for the limestone and alabaster for the city below. The main quarries of Hat-nub are a **five-hour** ride away, and were discovered in 1891. **Inscriptions** and **graffiti** on the **uncarved** faces tell that this site was worked from the dawn of the first dynasty until the completion of El-Amarna. They have not been worked since.

The deserts beyond El-Amarna are the home of the sand dwellers (see Call of *Cthulhu* 5th edition, page 118 for statistics). Many local Arabs will not travel here willingly, and some have tales of the unwise who were later found tom to shreds as if by the claws of beasts. Sand dwellers live in the wind-carved caves and under the ruins that litter the deserts of Upper Egypt. A twisted version of humanity, they are attracted to the deserts near El-Amarna by the presence of the Black Pharaoh, and await their chance to serve him again. Once he is reborn they become bolder, attacking expedition members and investigators, and venturing toward the river to raid the Arab villages on its banks.

Luxor and Environs

Luxor is a major center for the avid archaeologist. The site of the ancient city of Thebes, the area around **Luxor** positively bristles with tombs, ruined palaces and temples. To the north of **Luxor** is the Great Temple of **Karnak**, and across the river to the west **are** the temples of Thebes and the Valley of the Kings. All are very popular tourist attrac-

tions. General tickets of admission to **all** the tombs and temples are essential, and can be purchased from the Egyptian Museum in Cairo, the offices of **Thomas Cook & Son**, the Anglo-American Nile & Tourist Company in **Luxor**, or from the inspector of antiquities at **Karnak**.

The ticket price of 1 **£E** 80 P.T. allows unlimited **admission** to all sites for one year.



About Luxor

Luxor is 419 miles by railway from Cairo. The modern town sits on the east bank of the Nile, and has **all** of the facilities necessary for the modern traveler. Wide streets **are** lined by modern and traditional buildings. Stalls in the market and roving merchants extol the tourist to take home pieces of the buildings and the history of ancient Egypt.

Accommodations can be found at the Winter Palace Hotel, on the quay with excellent views of the Nile (open November to April, 220 rooms, 180 **P.T.**–300 **P.T.** per night); at the Hotel **Luxor** (Sharia el-Tsbitaiya, open all year round, 100 rooms, 130 **P.T.**–200 **P.T.** per night); or at the Thebes Hotel (**Sharia** el-Markaz, 24 rooms, 60 **P.T.** per night). A post office and telegraph office can be found near the **Winter Palace Hotel**, and **all** major consulates have offices here in winter.

Antiquities (50% are genuine) are sold by Mahmud Bey Muhasseb, Mansur Mahmud, and Girgis Gubrian from shops in the Sharia el-Lukanda, and by **Khamal** Khalid at the Winter Palace.

Guides may be found at the hotels or in the marketplace; the best are Girghis Mikhail, **Khalil** Ibrahim, and Taya Khalid, all of whom speak excellent English. They charge 20 **P.T.** for a tour of the Temple of **Luxor**, 30 **P.T.** for a tour of **Karnak**, and between 50 **P.T.**–70 **P.T.** for a tour of the monuments on the west **bank**. Girghis **Mikhail** is recommended for longer expeditions; his knowledge of the desert is reputed to be excellent.

Donkeys may be hired at the quay, railway station, and the hotels. The typical price is 30 **P.T.** per day; use of a side saddle is 5 **P.T.** extra. All hotels and steamers will provide packed lunches for tourists exploring the ruins.

SCENERY

To each side of the Nile at **Luxor** stretches a wide belt of very fertile land. Its flatness ends to the east and west with ranges of hills, topped with jagged peaks in the far distance to the east. Palms and vegetable crops fill every available acre of arable land; the ruins of the ancient temples jut out of the farmlands as if surprised to be there. They are ignored by the fellahin and traders; they are just part of the landscape.

The hills beyond the plains are always above the annual flooding of the Nile. The east slope of the Libyan range to the west of the river is peppered with the tombs of the pharaohs and their courtiers. Here is the fabled

Valley of the Kings, where the tombs of **Rameses III-IX**, Menephtes, **Tuthmosis I-IV**, and **Tutankhamun** attract tourists and archaeologists like flies to a corpse.

Karnak

To the north of the modern town of **Luxor**, the ancient ruins of **Karnak** tower above the palms. A short road from town crosses a canal after passing the law courts, church and schools of the American Mission and the Coptic Church. Beyond the canal the road passes the Roman Catholic cemetery. At a junction after the cemetery the road to the right leads to the Temple of Mut (the goddess of truth), while the road to the left runs straight to the Temple of Amun and the residence of the director of the excavations at **Karnak**. This house, a modern building, is open to visitors of **importance** and small workshops inside the building are used for cataloguing small objects.

The road to the Temple of Amun (and the road to the Nile and the Temple of Mut in the opposite **direction**) is flanked by **statues** of reclining rams, each bearing the **cartouches** of its sculptor and of one of the ancient pharaohs.

The Great Temple of **Amun** Ra, King of all the Gods at Karnak, is considered the best example of a typical temple of ancient Egypt. Its long axis runs at right angles

to the Nile. It towers above the plains and other minor temples that surround it. The majority of its huge pillars and pylons of stone have either survived the ravages of time, or have been rebuilt by archaeologists and the Egyptian Antiquities Department, which controls and excavates the site.

All who visit the site are awed by the sheer scale and size of the building. Every surface is inscribed with hieroglyphs, cartouches, and pictures. From any angle the temple appears to lean outwards, an optical illusion caused by the placement of the pillars and walls. Half a kilometer long, with pylons 120 meters wide, walls 18 meters thick, and pillars and walls 50 meters high, this is architecture of **truly** awesome proportions.

The First Pylon was never completed, **mudbrick** scaffolding still remains in some places. A staircase in the north tower leads to the top of the pylon; there is a great view from the top. Passing through the doors of the pylon, the Great Court opens out, with the temple of Rameses III to the far right, and a small temple to Sethos II immediately on the left.

The temple of Rameses III is guarded by two huge statues of the pharaoh; on the exterior of the temple's left tower, the pharaoh smashes a band of prisoners with a mighty club while Amun hands him the sword of victory and passes him the chained and vanquished leaders of his

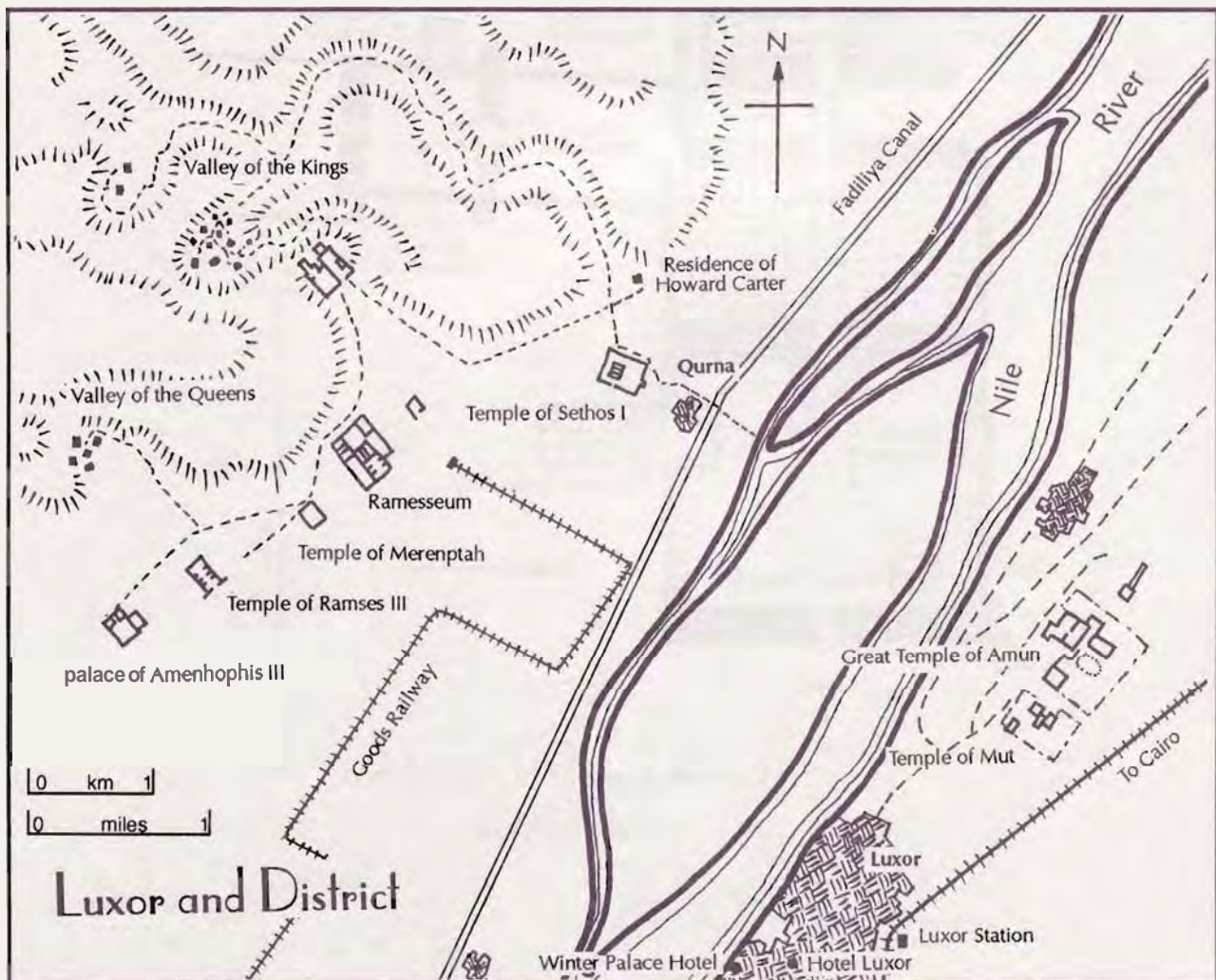

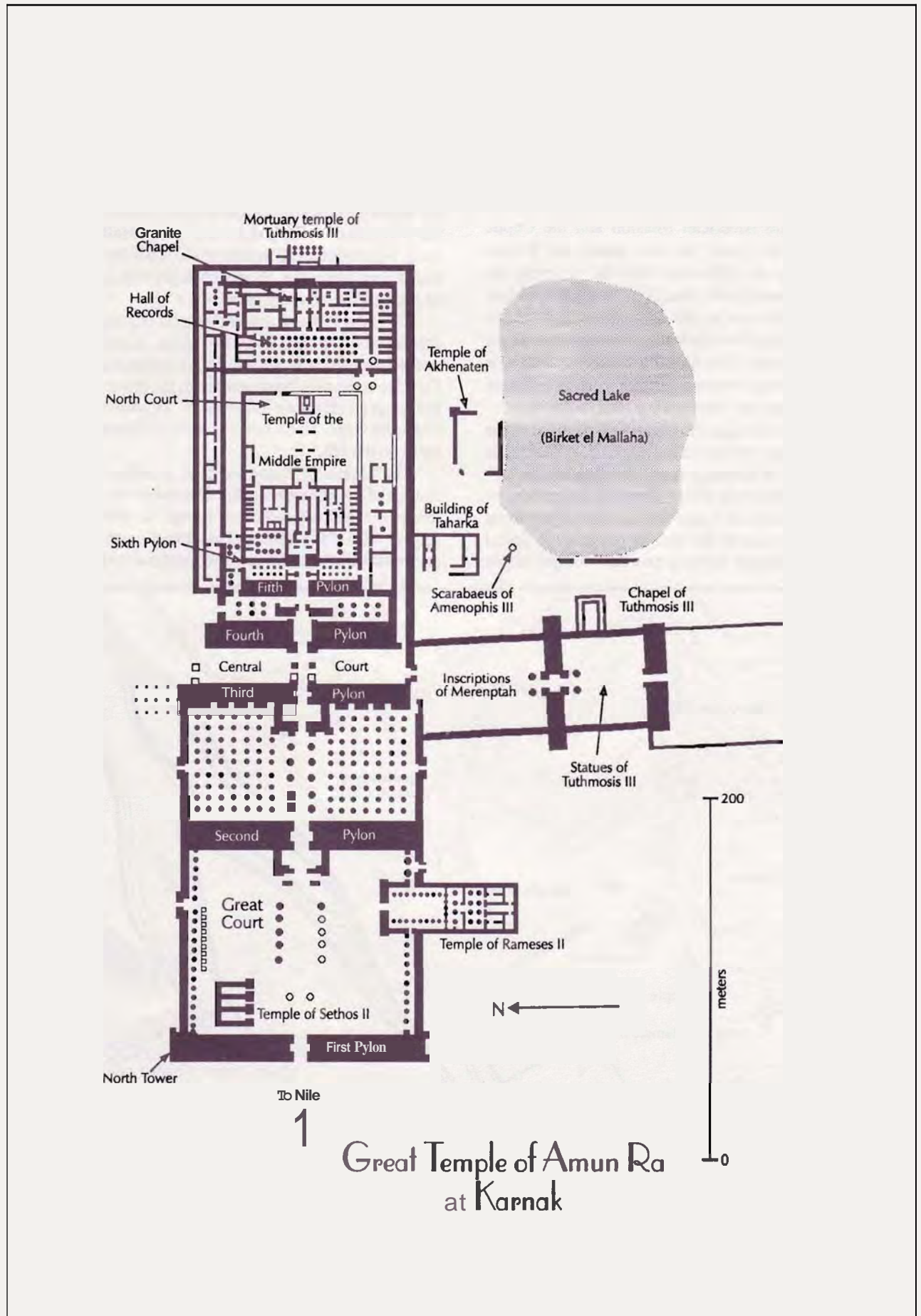

enemies. Within the temple are eight pillars, each in the shape of a colossal sculpture of Rameses III as Osiris. Inscriptions tell how Rameses III built the temple in honor of his father Amun.

Scenario Hook: An inscription carved to the right of the main door of the First Pylon by Napoleon's surveyors in 1799 lists the location of all the main temples in Egypt by longitude and latitude. Correcting by 10'56" for the change in the magnetic pole location between 1799 and the 1920's allows investigators to locate exactly any temple known by Napoleon. This listing includes several temples that have not yet been relocated and explored.

At the far end of the court a second **ornate** doorway leads through the Second Pylon into the Great Hypostyle Hall. The Great Hypostyle Hall, now missing its roof, is made up of one hundred and fourteen columns between 16 and 26 meters high and arranged in sixteen rows. Large enough to accommodate the entire cathedral of **Notre Dame** in Paris, it is 120 meters wide, 60 meters long, and has an area of more than 6000 square meters. The central two rows of columns are higher than the rest, forming a raised nave.

The pictures around the walls of the hall show the pharaohs of Egypt in battle. Defenders of the fortress of Kadesh (Palestine) are pierced through with arrows. The pharaoh transfixes a Libyan on his lance while around him are piles of the dead and wounded. Tallies of the heads, arms, and **tongues**—represented in **gruesome** detail as they are tom and cut from more than fifteen thousand prisoners—revolt many visitors.

The Third Pylon, now completely ruined, forms the rear wall of the Hall. Beyond this is the open Central Court containing an obelisk dedicated to Tuthmosis I and Rameses IV and VI. The bases of three more obelisks stand in a row, the obelisks themselves long since gone. Directly ahead is the Fourth Pylon, also largely ruined. Inscriptions on the doorway tell how it was initially restored by Alexander the Great when he came to the temple to be crowned king of all Egypt.

To the right of the court, the temple extends out into two further courts dedicated to Tuthmosis III and **Merentah**. To the left of these, outside the main temple, is a sacred lake rumored to have been used for ritual animal sacrifices; at its **northern** end a flight of great stone steps disappear below the surface of the extremely salty water. At its northwest corner are the ruins of a small temple, built by and dedicated to Amenhotep IV (Akhenaten), the heretic pharaoh of the 18th Dynasty. It contains numerous pictures of the sun god, **Aten**, and shows the pharaoh kneeling in worship alongside the lake. The sun god, in the form of a disk ringed by rays ending in hands, rises from the lake to accept the offerings of the souls of Akhenaten's captives.

Scenario Hook: The sacred lake, **Birket el-Mallana** (Lake of the Salt Pit), has never been drained or excavated. It contains many items of archaeological significance, as well as a few related to the **Mythos**. Rituals on one of the walls of Akhenaten's temple tell how to invoke the "one true god, Aten, who will rise out of the waters of the lake to devour the offered souls of humans." (Keeper's note: This is the ritual "Contact Azathoth", as the sun god worshiped by Akhenaten is the Outer God known as Azathoth. The use of this ritual requires the caster to be outdoors at night, and takes at least one point of permanent POW and 1d6 Sanity. Seeing Azathoth in all its chaotic glory costs 1d10/1d100 Sanity.)

Through the doors of the Fourth Pylon are the remains of a colonnade, a small courtyard with two lines of columns. All are dedicated to the rulers of the 18th Dynasty, many bearing the names of Hatshepsut and Tuthmosis I and III. All mentions of Amun in here were obliterated during the reign of Akhenaten (see Tel el-Amarna).

Through the Fifth Pylon are two ruined antechambers and two large courts containing statues of Osiris and sixteen-sided columns. Beyond these are the remains of the Temple of the Middle Empire: A passage leading to a North Court contains a seated colossus of **Amenhotep II** in red granite. Within the temple, beyond the Sixth Pylon, is the First Hall of Records, built by Tuthmosis III. Its walls contain detailed inscriptions of the life and conquests of the pharaoh and all of his predecessors. Two colossal statues of Amun and the goddess Amunet in red sandstone tower over all visitors.

Further on, the visitor enters the Granite Chapel, built for Philip **Arrhidaeus** (the "imbecile" half brother of Alexander the Great) between 323 and 317 B.C. Decorated entirely in the traditional Egyptian style, this chapel shows Philip paying homage to all of the traditional Egyptian gods, especially to Amun. The ruins of the Temple of the Middle Empire and the Temple of Tuthmosis III beyond are largely unremarkable, but are totally covered with hieroglyphic inscriptions, many yet to be recorded and translated.

AROUND THE GREAT TEMPLE

Many smaller temples dot the area surrounding the Great Temple of Amun. These date from all periods, from the 5th Dynasty to **Ptolemaic times**, and include temples to Rameses II, Osiris, Mont, Mut, Rameses III, and Hatshepsut. Many are badly mined, many are yet to be excavated, and even more lie beneath the rubble and sand waiting to be discovered. The team from the Egyptian Antiquities Department are working slowly toward the restoration and excavation of many of these, but there is never enough funding or workers to keep up with the task at hand.

Thebes

The ancient capital of Egypt, Thebes once spanned both banks of the Nile and included Karnak. The name of Thebes is now used exclusively for the complex of temples and tombs that cluster in the foothills on the west bank of the Nile. It is at this site that the majority of excavations occur in the 1920's.

The great temples in the lower hills of Thebes were excavated in the middle to late 1800's; by the 1920's the bulk of the excavation has moved to the Valley of the Kings beyond, with only the dedicated staying behind to complete the excavations and restorations of the less romantic, but more historically significant, temples.

A ferry runs across the Nile from Luxor. The road from the dock to the temples passes several farms, and gradually winds higher into the foothills. After two kilometers the road from the ferry forks. The left fork leads to the temples and necropolis at Thebes; the right fork leads further into the hills to the Valley of the Kings. A minor road to the right just before the fork leads to the house built in 1924 by Howard Carter, the discoverer of the tomb of Tutankhamun. He uses this residence all year around.

THE TEMPLES AND NECROPOLIS

Most of the temples are dedicated to Amun. Many doubled as mortuary temples, and were used for the rites involved with the preparation of the bodies of the deceased before they were entombed to await rebirth. Around each temple clustered the dwellings and buildings of those closely involved in the death industry: the houses of the priests, libraries, and the schools, as well as the granaries, the stables for the sacrificial animals, guards' barracks and prisons. Near the temples were the villages that housed the workmen involved in the construction of the temples and the tombs in the hills and valleys above, as well as the houses of the embalmers, sculptors, painters, and stonemasons. The city that eventually arose was governed by the "Prince of the West and the General of the soldiers of the Necropolis."

The main temples here are the Mortuary Temple of Sethos I, the Temple of Tuthmosis III, the Ramesseum, the Temple of Merenptah, and the Temple of Ramesses III. Tombs surround each temple, many of them for minor officials and artisans. The majority were looted thousands of years ago; a few have been discovered largely intact. The largest of the temples is the Ramesseum; while much of the temple is in ruins, the grandeur of what remains is undeniable.

The Mortuary Temple of Sethos I

Originally started by Sethos I, this temple was completed by Ramesses II. Only one quarter of the original structure remains, the colonnade at the front of the temple still truly magnificent after thousands of years. Its nine papyrus-style columns with flaring bud-shaped tops are in excellent condition.

Through the doorway, the Hypostyle Hall contains six more columns, flanked on each side by three chambers. Between them, on fallen roof slabs from the center aisle,

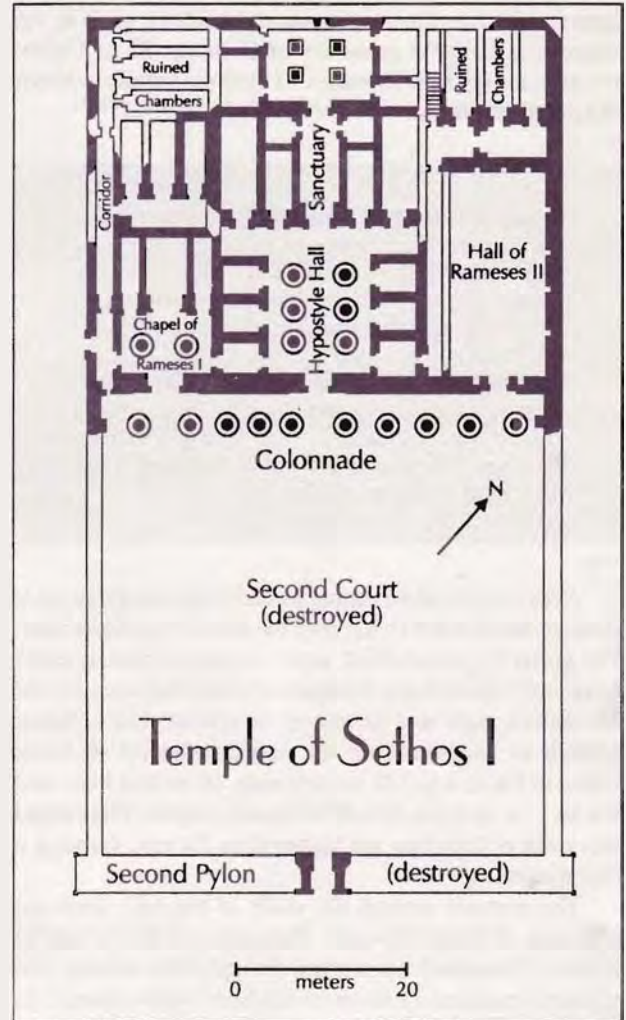

the winged sun-disk, flying vultures, and the name of Sethos I can be seen in a frame of serpents. Reliefs on the walls show Sethos I and Ramesses II sacrificing to the gods; others show the cow-headed goddess Hathor suckling the adult Sethos I. Rooms beyond the Hall show reliefs of Sethos I and Ramesses I with other animal headed gods: Set, Isis, and Horus. Most involve rites associated with the death of the pharaohs.

The Ramesseum

A 45-minute ride by donkey from the river, this temple has a rest-house and refreshments tent at its southwest side. The rest-house and refreshments are available only to tourists booked with the Anglo-American Nile & Tourist Company, or patrons of the Winter Palace and Luxor Hotels at Luxor.

Only half of the originally massive Ramesseum is still preserved, but what remains is impressive. This is the tomb of "Osymandyas" mentioned by the Greek historian Diodorus in the 1st century B.C. the name Osymandyas being a corruption of the forename of Ramesses II, "User-ma-re."

The original entrance to the temple at the east was through the Great Pylon; this is largely ruined, and looks more like a stone quarry than the imposing 70-meter-wide wall it once was. Reliefs on the inner side of the pylon tell

of Ramesses II's campaigns and victories in war over the Hittites in the fifth year of his reign. Soldiers and the pharaoh ride into war in chariots against impossibly long arrays of enemies and mow them down, showing no mercy to any, spearing or beheading most. Captive leaders and priests are brought back in chains and sacrificed to the Egyptian gods.

The first court beyond the pylon is mind; the remains of the colossus of **Ramesses II** lie in fragments. Once the largest statue in Egypt (each ear is more than a meter long; the total height of the seated figure would have been more than 20 meters), its head lies fallen to the ground, much of its face destroyed. The name **Ramesses II** appears several times on the arms and legs, and the remaining parts (chest, upper arms, one foot, and seated legs) tell of the skill of the artisans who sculpted it. These ruins inspired the romantic poet Percy Bysshe Shelley to compose the sonnet "**Ozymandias** of Egypt" telling of a traveler to Egypt who comes across a ruined colossus. The poem contains the famous lines:

*And on the pedestal these words appear:
"My name is Ozymandias, king of kings;
Look on my works, ye mighty, and despair!"
Nothing beside remains. Round the decay
Of that colossal wreck boundless and bare,
The lone and level sands stretch far away.*

Beyond the remains of the colossus, the second court is entered through a gap in the wall. Again largely in ruins, the remaining carvings include many larger-than-life statues of **Ramesses II** as **Osiris**. Wall frescoes again tell of the pharaoh's defeat of the Hittites at the **Battle of Kadesh**, and mutilated and skewered corpses lie strewn at the feet of **Ramesses II** as he strides over the bodies. Two more colossal statues once sat in this court; parts of one are in the Egyptian Museum and parts of the other are in the British Museum.

The vestibule at the rear of the court is reached by three flights of steps. Three rows of bas-reliefs show the eleven sons of the king, the king being escorted by the gods **Atum** and **falcon-headed Mont** holding the ankh of life at the king's mouth, and the king kneeling before the Theban gods while ibis-headed **Thoth** writes his name in the Book of the Dead.

Through the vestibule is the **Great Hypostyle Hall**, containing eight rows of six papyrus bud columns, many of which still stand although the roof no longer remains. Similar in design to the hall at **Karnak**, all of the columns show the pharaoh destroying his enemies, while the walls tell yet again of the triumph over the Hittites.

Surrounding the temple are the foundations of the storehouses. Built of sun-fired bricks, these once held grain and oils, as well as the arms and armor of the pharaohs' armies. The walls are long gone, but the extent of the complex is huge, and thousands of tons of equipment and food could once have been stored here.

The Main Temple of Ramesses III

Built to the same plan as the Ramesseum, but smaller in size, this temple is mainly intact, with only the roof missing. The walls tell of the exploits in war of the pharaoh, and of his worship of the Theban and Egyptian gods. One wall describes how the king stood atop a tower built of the slain heads

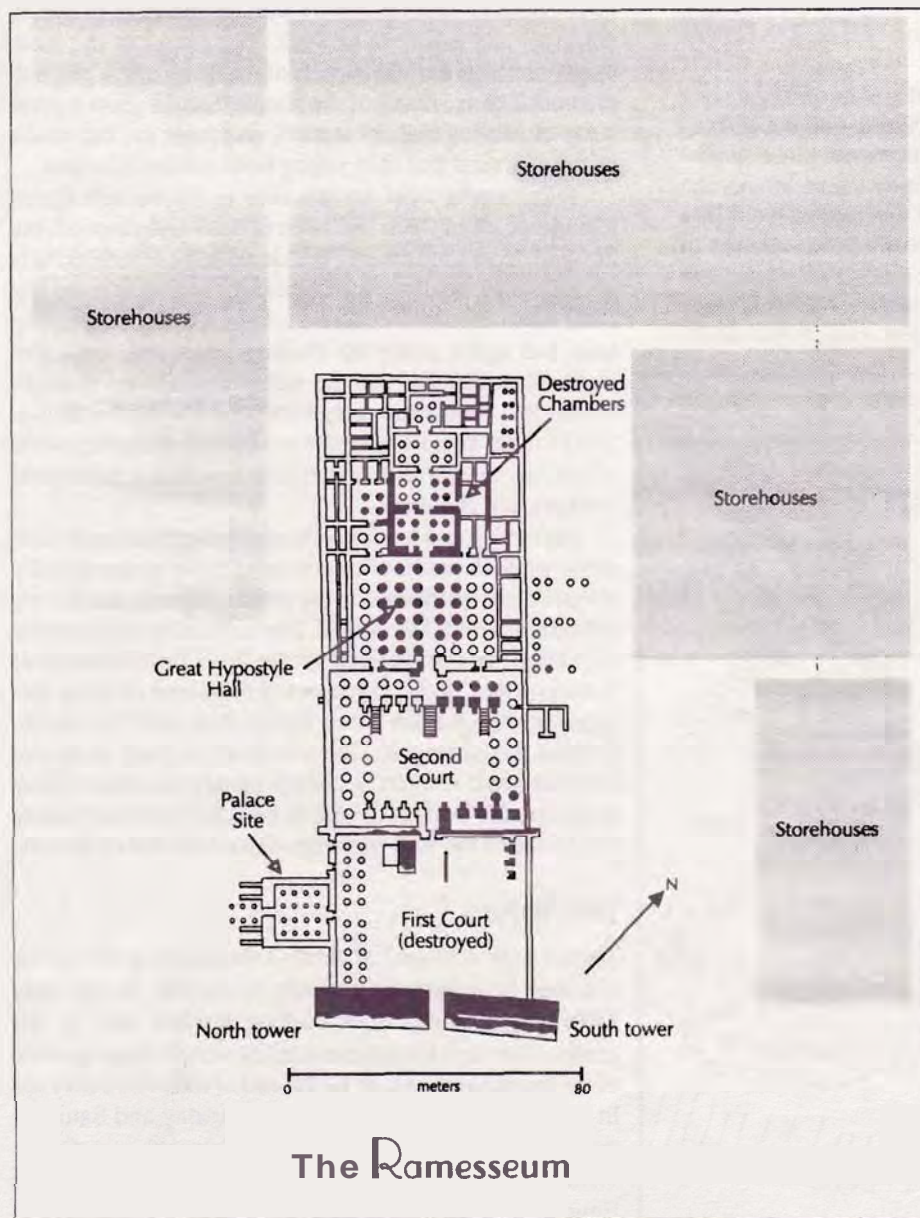

of his enemies and used his archery skills to kill yet more, while his court, wives, and children danced with delight.

The treasury, off ~~the~~ Hypostyle Hall and ruined as in most other temples, contains painted walls showing the pharaoh offering vast platters of silver, gold, lead, and jewels to the god **Amun**. Other wall reliefs tell of his victories in battles at sea, defeating a vast army of ships at the mouth of ~~the~~ Nile, and sinking most with no mercy for their occupants.

Valley of the Kings

A 45-minute donkey ride from the Nile River at Thebes.

Above the temples of the pharaohs at Thebes, a narrow and winding road leads up into the Libyan hills. This is rugged country, dry and desolate. Crumbled rocks fall off the cliffs periodically, and the edges of the narrow path are treacherous and slippery with gravel. The road turns sharply westward and opens into a forked high valley or ravine. This is the **Biban el-Muluk**, the Valley of the Kings, the most famous place in all of Egypt in the 1920's. Here the tombs of the pharaohs of the 18th to 20th Dynasties are cut into the living rock.

For over a thousand years the pharaohs of Egypt were entombed in deeply carved shafts cutting into the cliffs of the Libyan hills. This is a stark and barren place, a sun-scorched wilderness of rock and dust. In midsummer the heat reflecting off the cliffs makes the valleys feel like a furnace; in winter it is not much cooler. The isolation of this desolate valley appealed to the ancient pharaohs; this was a place to which even the hardest of tomb robbers would hesitate to venture. It was to be a place that would

keep its inhabitants safe from the **greed** and ravages of living **man**.

All of the tombs here show similar structure and internal arrangement. None **are** marked above ground level; there **are** no pyramids or temples in the valley. Either stairs or a steeply sloping passage cut into the stone, eventually leading into an entrance gallery. There **are** often deep pits interrupting the slope or stairs, maybe designed to catch and trap tomb robbers or perhaps only to prevent the entry of water into the tomb. The passage continues beyond the pit and opens into a wider entrance gallery; chambers and halls branch off it with the farthest one usually containing the sarcophagus of the pharaoh or the high **official** to whom the tomb is dedicated.

In some tombs **there** were a **number** of false sarcophagi in the earlier **rooms** of the complex, placed there to satisfy the tomb robbers early, and to prevent them from looking for the secret doorways that led to the real treasures.

The tombs vary in size and complexity, from the simplicity of the short tomb of **Tutankhamun** to the labyrinthine complex of **Rameses III** with its hundreds of feet of corridors and exquisite artwork. The extent of the tomb usually reflects the suddenness of the death of the pharaoh entombed there; many of the simpler tombs show a great haste of carving and decoration, and these **are** the tombs of the pharaohs that died young from sudden illnesses.

Forty tombs were known here to the ancient Greek historians; all of them had been opened and emptied, but the wall decorations were considered to be breathtakingly beautiful. By the time of the French **expeditions** in the late 1700's less than ten remained uncovered, the rest having been lost again under the shifting rocks and sand. The flurry of excitement that the valley engendered throughout the late **1800's** and early **1900's** means that by the late 1920's more than sixty tombs are known, including some which **are** merely pits and others containing household workers, not pharaohs.

Mummies and tomb goods, many worth several thousands of dollars to collectors, have been systematically removed and distributed to the great museums and private collections around the world. The only real treasures from the valley that remain in Egypt **are** those from the tomb of **Tutankhamun**, and it is suspected that some of those disappeared into private hands before they could be photographed and catalogued. There is an active trade in ancient Egyptian tomb artifacts, and there are always those willing to destroy the walls of a tomb to be able to sell incomplete fragments of the wall paintings to tourists and collectors.

THE TOMBS

Tours can be arranged of eight of the tombs in the valley, although seventeen are actually accessible. In the early 1920's light comes from burning torches held by the guides. The soot from these torches was destroying some of the finest paintings, so by the end of the **1920's** they **are** lit by electric lights on Tuesday, Thursday and Saturday mornings. After 1924 the tomb of **Tutankhamun** can be visited, but only by special appointment made with the Egyptian Antiquities Department.

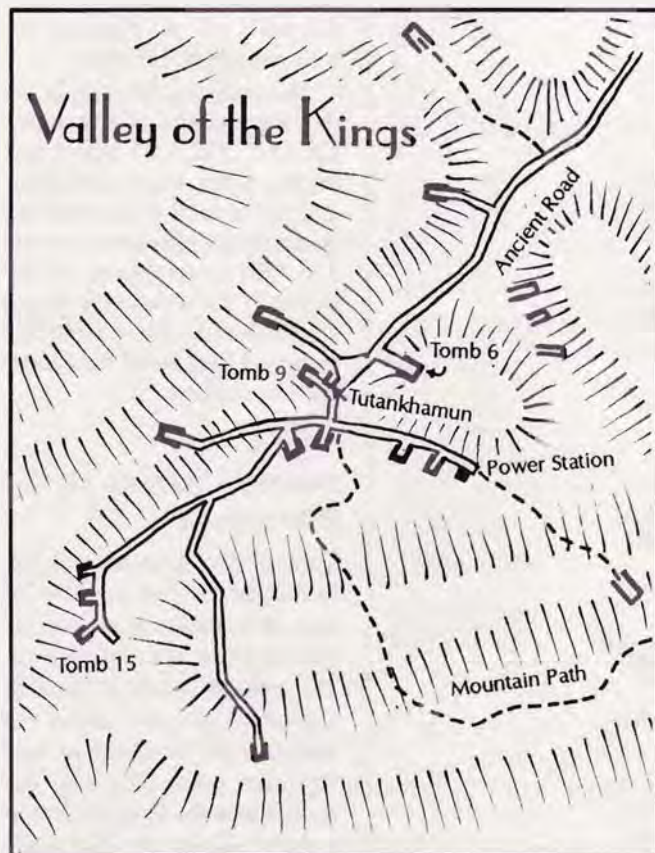



Workshop of the Egyptian Museum

Tomb number 15 in the Valley of the Kings (the tomb of Sethos II) is used throughout the middle to late 1920's as a workshop area for the initial restoration of items from **Tutankhamun's** tomb. Armed guards patrol the area of this tomb at all times of day and night.

All items found in the tomb are initially brought to the workshop for assessment and cataloguing by the expert staff on site. More than twenty staff **are** here at any one time, with as many as sixty during the period 1923-1925, when the majority of the items from **Tutankhamun's** tomb are being catalogued and restored.

All work is overseen by officials from the Egyptian Antiquities Department, and no items **are** allowed to leave the workshop area without written authorization. Extremely valuable treasures are constantly under armed guard. Despite the obvious security, the workshop appears to be in a state of utter chaos, with priceless artifacts covering every available flat surface, many piled on top of each other in storerooms at the rear of the tomb. Conditions are not ideal for long-term storage, and small items that disappear are often not missed for months or years.

Several staff at the workshop are involved in occult activities. Garth Weder, a senior curator from the Egyptian Museum who spends half his time here, has significant occult connections. His personal assistants **Hasan** and **Ali** have basic training in occult matters, and **are** under strict instructions to bring items of occult or Mythos significance directly to him. Many of these items **are** never catalogued, and disappear directly into Weder's

personal collection; others are catalogued and taken directly **to the Museum, where they are stored in the four secret rooms on the ground floor or in closed tunnels in the basement.**

While Weder is dedicated to his cult **affinities**, his assistants **are** in the business purely for the money. An offer of more pay and safe passage away from Weder is **enough to buy their loyalty and the items they are currently working on.**

Tomb of Rameses IX (Tomb Number 6)

A flight of steps on each side of a ramp leads down into the tomb. On the right side of the staircase is an unfinished inscription to the **king**. A long corridor extends inward. Four small chambers branch off of the main corridor at the start; all contain wall inscriptions and paintings from the *Book of the Dead*. The **king** is shown standing before the gods of the dead. Further down the corridor a painted serpent rears up from the wall to the roof, and more text from the *Book of the Dead* lines the walls.

On the right wall, demon-like creatures and serpents are shown entrapped in oval rings. Further down the hall three rows of demons stand one above the other, in the top row are eight suns, each containing an inverted Black Pharaoh (a successful **Cthulhu Mythos** roll here **makes** an investigator viewing these images speculate as to whether this may be a representation of Nyarlathotep). The rooms at the end of the corridor are empty, the **king's** mummy having been reburied at Deir el-Bahari. The inscriptions in the rooms are badly damaged.

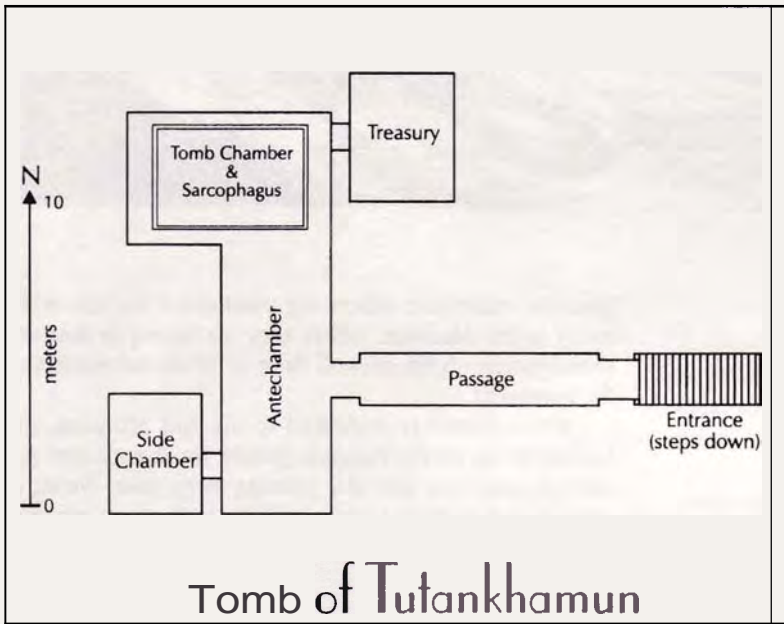
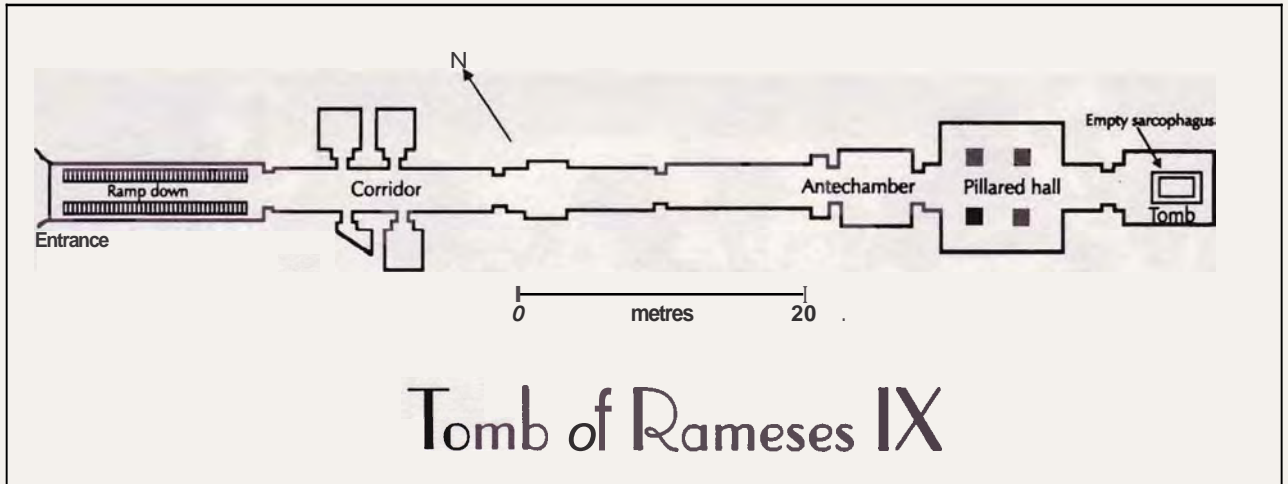

Primary Tombs of the Valley of the Kings

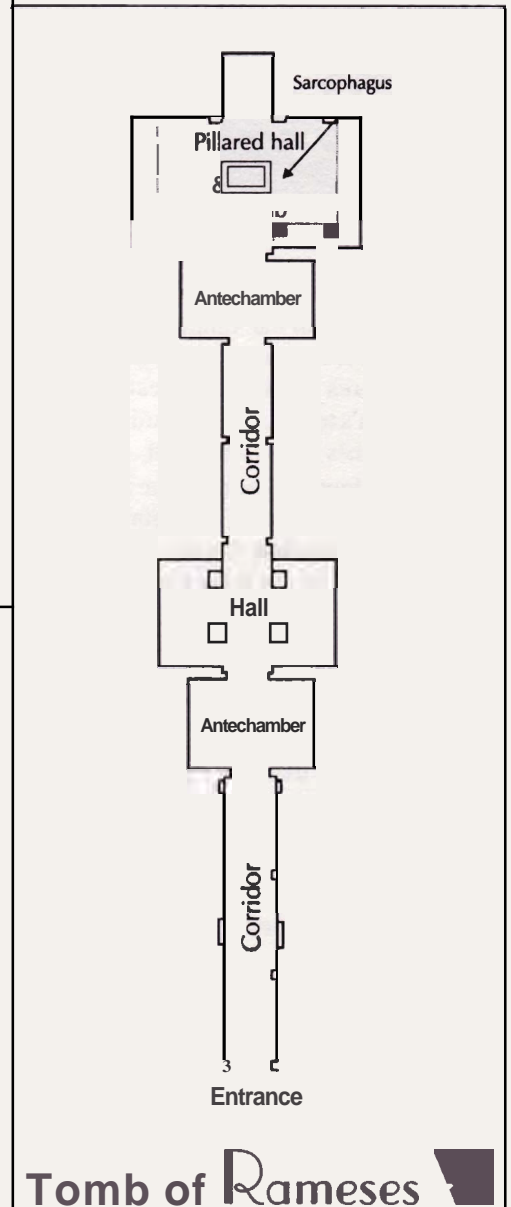

A Timeline of Discovery in the Valley of the Kings

1769: James Bruce (U.K.) discovers tomb of Rameses III. It is empty.

October 1817: Giovanni Battista **Belzoni** (Italy and U.K.) discovers tomb of Sethos I **partially** intact.

1876: Papyri and tomb goods of the 21st Dynasty begin to appear on the market from an unknown tomb.

1881: Mohammed Abd-er-Rassoul leads Emile Brugsch Bey, Service of Antiquities, to the entrance of a network of catacombs containing a large number of sarcophagi and mummies removed from their original tombs and reinterred here during the end of the 21st Dynasty. This catacomb, the Deir **el-Bahari**, contains the mummies of Amenhotep I, Queen Ahmes **Nefertari**, Thutmosis II and III, Sety I, Rameses II and III, and many others. The mummies and some of the later tomb goods are largely intact.

1881-1886: Removal of tomb goods and sarcophagi from Deir el-Bahari catacombs to new Egyptian Museum at **Bulak**, overseen by Sir **Gaston Maspero** and Brugsch. Crowds line the Nile to watch barges loaded with sarcophagi sail past.

1898: M. **Loret** discovers tomb of Amenhotep II. The mummy was still present in the sarcophagus, the first pharaoh to be found still in his original tomb. Most of the tomb goods had been looted, but the sarcophagus was untouched. In side chambers off the main tomb are nine royal mummies, including those of Thutmosis IV, Amenhotep III, and Rameses IV-VI. Amenhotep II is left in place in the tomb.

1901: Tomb of Amenhotep II is robbed, and many items are stolen despite the presence of armed guards.

1902: Theodore M. Davis (U.S.A.) provides funds for continued excavation in the Valley. He initially employs Howard Carter (later replaced by Weigall and then **Ayrton**) as representative of the Service of Antiquities.

1903: Carter discovers tomb of Thutmosis IV. The mummy had already been found in the tomb of Amenhotep II, but most of the funerary furniture (broken) is still present.

1902-1912: Tombs of Queen Hatshepsut, **Siptah**, and Horemheb found by Davis-funded expeditions.

1905: Davis, Maspero and Weigall discover the tomb of Yuaa and Tuau (grandparents of Akhenaten), untouched and totally intact. Davis almost ignites the **bitumen**-soaked wood-lined walls of the tomb with his candle; this would have destroyed the tomb and all contents. This is the greatest discovery until the tomb of **Tutank-**

hamun is found, containing many papyri, gold and wooden statues and magnificent sarcophagi.

1906: Davis finds a small tomb, hastily plugged with clay, containing a number of artifacts bearing the name of Tutankhamun. He believes it is the looted tomb of Tutankhamun, and announces its discovery. Others are skeptical.

1907: Carter begins explorations under the patronage of Lord Carnarvon.

1907: Davis and Weigall discover the tomb of Queen **Tiye**, mother of Akhenaten, containing instead the mummy and sarcophagus of Akhenaten glittering "as if all the gold in ancient Egypt gleamed in that narrow space." Davis denies the mummy is that of Akhenaten, claiming it to be that of **Tiye** even when the skeleton proves to be that of a **man**. The entrance to the tomb is sealed with the seal of **Tutankhamun**, suggesting he was responsible for placing Akhenaten here.

1908: Discovery of the tomb of Horemheb by Davis. The tomb has been plundered, but the sarcophagus is intact.

1912: Carter and Carnarvon publish a monograph titled "Five Years' Exploration at Thebes" telling of their limited success to date.

1915: Davis abandons work in the Valley. Exploration rights are picked up by Howard Carter under the patronage of Lord Carnarvon. Carter and Carnarvon continue exploration and minor excavation all through the Great War.

November 5, 1922: Carter discovers a sealed doorway leading to a tomb. He wires Carnarvon to come to Egypt at once.

November 26, 1922: Carter and **Carnarvon** open the tomb to discover "wonderful things!" The tomb is largely intact; the looted outer chamber led to a false door that went nowhere. The real tomb lies through a secret doorway elsewhere in the outer chamber.

November 30, 1922: A wire is sent to all the major newspapers in the world stating: "This afternoon Lord Carnarvon and Mr. Howard Carter revealed to a large company what promises to be the most sensational discovery of the century ... the funeral paraphernalia of the Egyptian King **Tutankhamun**, one of the famous heretic kings of the **XVIIIth** Dynasty."

December 1922: Carnarvon comes down with a severe infection as a result of an insect bite to the face.

April 1923: Carnarvon dies in Cairo. Rumors spread that it is the "curse of the pharaohs" at work.

Tomb of Rameses VI (Tomb Number 9)

A long corridor leads to an antechamber, and then into a pillared hail. Beyond that a second corridor section leads to a second antechamber and then into a second pillared hall containing the sarcophagus of the pharaoh. The walls of the corridors and halls contain much of the text of the *Book of the Dead*, along with the *Book of Portals* and the *Book of That Which Is in the Underworld*. These *three* form the Egyptian **trilogy** on death and rebirth. Spells given in hieroglyphs **are** annotated in Greek and Coptic writing, indicating that this tomb was open and studied by scholars and mystics of Greek and early Christian times.

Tomb of Tutankhamun (Tomb Number 58)

This tomb is immediately down the hill from the tomb of Rameses VI, and is open to visitors only by prior arrangement with the Department of Antiquities. Photography inside the tomb, and of objects being removed from the tomb, is totally forbidden. Cameras **are** confiscated from those who break this rule.

Sixteen steps (5 feet wide and 13 feet long) lead down into a passage 25 feet long and 5-1/2 feet wide. This opens out into an antechamber 26 feet long and 8-1/2 feet wide, which is the largest room in the tomb. This room is crammed with furniture and offerings when the tomb is first opened. At **the west** is a **small side** chamber. Two life-sized wooden statues of the **king** that once stood here have been removed to allow access. Lit by electric lights, the tomb chamber can be seen through the side chamber.

At the center of the tomb is a rectangular sarcophagus of yellow sandstone. The sides of the sarcophagus are carved with hieroglyphs and at its corners are carved four indescribably beautiful winged guardian goddesses. They appear to protect the body of the king inside with their outstretched wings. Within the sarcophagus is the outer wooden coffin containing the mummy of the king. The elaborately decorated and inlaid inner wooden coffin and the gold funerary mask of the king have been removed by late 1923, and won't be on public display at the Egyptian Museum in Cairo until 1929. The tomb paintings appear to be quickly done and are unremarkable both in content and style, showing the king making offerings to the gods of the underworld.

Scenario Hook: One of the graduate students involved with the translation of some of the papyri recovered here is being courted by a female member of the Brethren of Seth. She intends to use the spells he is discovering to reanimate the mummified body of an ancient priest of Seth, kept in the basement of her house in Cairo. She hopes that the priest, once animated, will teach her all he knows. She intends to kill the student when she has what she wants from him.

Aswan

Aswan lies 548 miles by rail from Cairo up the Nile Valley and 129 miles (4-1/2 hours) by rail from **Luxor**. Trains to **Aswan** from **Luxor** run twice daily, the line alternately skirting the east bank of the Nile and then the edge of the **desert**. **Aswan** is the turnaround point for the Nile steamers, and most cruises spend two to three **days** berthed **here**.

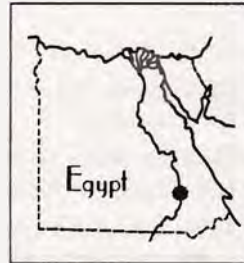

Aswan is a fairly modern and clean town on the east bank of the Nile, just downstream of the **first** cataract. The rocky cataracts of the Nile constrict the flow of water **traffic** both up and down the river; he who controlled the cataracts once controlled trade on the Nile. The **Aswan** Dam, three miles above the town, was built between 1898 and 1902. It has altered the annual flow of water down the river, and the water that once ran white and foamy over the rocks of the cataract now idles past all year around.

Elephantine Island, a large island at the center of the Nile River, bears the remains of a number of ancient towns. The most recent was the town of Elephantine, founded by the Roman Emperor Trajan around 110 A.D. A smaller island between Elephantine Island and the mainland, Kitchener's Island, was formerly owned by Lord Kitchener. It now belongs to the government, its fine house and gardens cared for at the expense (and annoyance) of **the** local counselors.

Beyond **Aswan** to the east stretches the vast expanse of the Sudan Desert, populated by the nomadic Bedouin tribes. To the west, across the river, **are** the endless sands of the Libyan Desert. The river runs like a lifeline of civilization through the sands of eternity.

The Town

Aswan has a number of hotels for travelers. The Old Cataract Hotel is the finest (280 **rooms**, 180 **P.T.**–300 **P.T.**), and is situated on the bank of the Nile immediately opposite Elephantine Island. The view by moonlight from the hotel windows—white-sailed feluccas drifting across the deep indigo of the Nile, between Kitchener's Island and the mainland, while the granite boulders gleam in the crisp white light—is breathtaking.

OTHER HOTELS

The Grand Hotel on the quay (80 **rooms**, 130 **P.T.**–200 **P.T.**). The Savoy Hotel on Elephantine Island (open until 1926). The **Khedivial** (cheap and nasty, 40 **rooms**, 50 **P.T.**). All hotels offer half-price rooms during the summer.

HOSPITALS

Just outside the town is the Assuan Camp, run by Mr. M. G. **Hedra**. It is a sanatorium for sufferers of rheumatism,

kidney disease, and "nervous complaints." It has 40 rooms, and full board is 70 P.T.–100 P.T. per day. No guarantees are made of a cure.

OTHER AMENITIES

The town has the usual post office, telegraph office, doctors (Drs. Moore and Neylon, both English), pharmacy, banks, and representatives of Thomas Cook & Son and the Anglo-American Nile and Tourist Company (both at the Grand Hotel). Recommended guides are Muhammed Sherqawi and Ahmad Abd el-Maula; they are also experts on the Sudan Desert that begins just outside the town precincts.

The Surrounding Area

The ruins of the ancient Egyptian and later Roman town of Elephantine are a one-hour diversion for the visitor. Unrestored and unexplored, they may yet contain treasures of Roman life, but few archaeologists want to spend their time on Romans while there are so many older monuments yet to be discovered and restored. The island is also the site of the Aswan Museum (open 9:00 a.m.–4:00 p.m., closed Fridays and holidays, admission 5 P.T.), which contains a good collection of antiquities from Lower Nubia. Items on display include the mummy of a sacred ram, pots and stone vessels from the prehistoric period of Egypt (4000–3200 B.C.), an ancient skull showing a healed fracture, and mummies from the Middle Empire and Ptolemaic period.

To the south of Aswan are the granite quarries, Mahagir, that were the source for much of the fine granite used in the construction of tombs, statues, and monuments built further down river in pharaonic times. The north quarry contains an unfinished obelisk, 50 meters long and 4 meters thick at the base, which would have weighed over 1100 tons when finished.

Blocks were detached from the granite cliffs by boring holes into their tops, inserting wooden pegs into the holes, wetting the pegs, and then letting the expansion of the wood as it absorbed the water do the job of splitting the block off the cliff face. Many roughly carved blocks lie at the foot of the quarry, waiting for stone masons long gone to complete the trimming. Some bear the cartouches of the masons that were working on them and of the pharaoh (Amenhotep III) that commissioned the work.

Five minutes' walk from the quarry is an eight-meter high statue of Osiris (called Rameses by the locals) that stands on a high point looking out over the desert to the east and north.

On the west bank of the Nile, north of Elephantine, are the rock tombs of its princes and nobles. A general admission ticket is required to enter them. A sandy path rises from the river bank to the top of the cliff that contain the tombs.

The tombs are mainly empty. Their paintings and reliefs show pictures from the Book of the Dead. Two of the tombs were later used as retreats by Coptic monks, who annotated the hieroglyphic inscriptions with Coptic graffiti (possibly commenting on the usefulness of some of the spells given in the Book of the Dead). The remains of a Coptic convent squat on the cliff top further downriver.

Scenario Hook: Careful study of the Coptic graffiti reveals that the annotations discuss the experiments that the monks performed in casting spells from the Book of the Dead using more commonly available, non-standard components. Most of the spells no longer functioned, but some did, albeit with slightly altered results.



People in Egypt

"This man, a shaven, peculiarly hollow-voiced and relatively cleanly fellow who looked like a Pharaoh ..."

Who's Who in the 1920's

Allenby, Lord Edmund (1861–1936) — British High Commissioner to **Egypt** from 1 April 1919 to late 1925, when he is replaced by Lord Lloyd. **Allenby** was the Commander-in-Chief of the British Forces in the Middle East during the Great War. He and his wife often welcome important visitors to Cairo, receiving them in their own home.

Budge, E. A. Wallis (1857–1934) — Former head of the British Museum's Department of Egyptology. Now in his seventies, Wallis is still a frequent visitor to Egypt and Cairo throughout the 1920's. The leading expert in the world on the gods and language of the ancient Egyptians, he has written several books on the subject. He always stays at Shephard's in Cairo, or with Howard Carter at Thebes.

Carter, Howard (1873–1939) — Archaeologist and explorer in Egypt from the age of 16. Starting in 1915 he has sole exploration rights in the Valley of the Kings. He resides at a house just off the road between **Thebes** and the Valley of the Kings when he is in Egypt, but can occasionally be found at Shephard's Hotel in Cairo. He is usually very shy of publicity, especially after **Tutankhamun's** treasure is discovered.

Churchill, Winston (1874–1965) — The future Prime Minister of England. Churchill is involved in the negotiations regarding Egyptian self-rule, held in Cairo in 1921. He is staying at Shephard's Hotel, and is frequently visited by T. E. Lawrence. A rounded, earnest young man, he has a keen interest in history.

Fuad, Sultan (King) (1868–1936) — The highest ranking prince of the Egyptian royal family, Fuad is made King of Egypt in 1922. A frequent visitor to the **Muhammed** Ali Club and the Automobile Club, he is fond of gambling and attractive western women.

Graves, Richard (Dick) (1880–1960) — **Inspector** of the Interior to the Fayoum Province. Dick's brother, Robert Graves, visits him frequently in Egypt. The two brothers

are often found at Shephard's Hotel in Cairo, and at the Egyptian Museum inspecting the latest discoveries.

Graves, Robert (1895–1985) — Noted British author, historian and mythologist (author of *The White Goddess* and *I, Claudius*). He has a passionate interest in the gods and myths of ancient Egypt, and will frequently be found **tracking** down the same cults as investigators, not necessarily for the same reasons. [See Graves, Richard.]

Gwynne, Bishop Llewellyn (1863–1957) — Anglican (Protestant) Bishop of Upper and Lower Egypt and Cairo from 1920–1945. Influential in all British circles in Cairo, he is willing to help a Briton in trouble.

Hassanein Bey — A noted Arab explorer in the 1920's, specializing in the Libyan **Desert** region. He is known by most of the Bedouin tribes of the Desert. **On** attachment to the American and British legations throughout the 1920's, he becomes Inspector General of the Egyptian Government in 1929.

Jays Bey, Lt. Col. "Kaimakam" — High up in the Alexandria Police Force, he has an excellent knowledge of the ancient Greek language, and has conducted a long study of the Greek ruins in and around Alexandria.

King of the Wasa — A huge Nubian man, he controls the drug and white slave trades in Cairo throughout the 1920's. He has powerful friends in very high places.

Lloyd, Lord George (1879–1941) — British High Commissioner to Egypt from October 1925 to July 1929. He replaces Lord **Allenby**, and has a difficult struggle dealing with the political turmoil throughout the second half of the 1920's. He is friendly to important visitors, inviting them to dinner at his club (Automobile Club).

Loraine, Sir Percy (1880–1961) — British High Commissioner to Egypt from August 1929. He replaces Lord Lloyd.

McPherson, Joseph "Bimbashi" (1866–1946) — Head of the British Secret Service in Egypt until 1920, he then operates free-lance throughout the 1920's. A strong campaigner against drugs in Cairo, he operates Cafe Marschino to obtain information on the Egyptian drug trade, and on the people involved in the assassinations of British nationals in Egypt. Willing to assist investigators, he has contacts in high government circles.

Pratt, Miss Ida — The author of an excellent book on ancient Egyptian sources in the New York Public Library, Ida is frequently found in Egypt researching the ancient gods and history. In her thirties, and still single, she usually stays at Shephard's or Mena House Hotel.

Reisner, Dr. George A. (1867–1942) — Head of the Harvard University Excavations at the Pyramids of Giza and the Sphinx. He has been excavating here since 1910. His camp is at Gezireh; he discovered the tomb of Queen Hetepheres (**Cheops'** mother) in 1925. He can be found at the bar of the Mena House Hotel most evenings.

Russell Pasha, **Thomas** Brigadier (Lewa) — Head of the Egyptian Police Force. The head of the campaign against the drug trade in Cairo. He is also a noted ornithologist (bird collector) and **keen** sport shooter and hunter.

Sachioni, Signor — Italian Consul to Cairo until 1925, when he disappears mysteriously. **The** reason is never discovered.

Seddick Bey — Governor (**Mudir**) of the Fayoum Province. Friendly to travelers, he often places his car and launch at their disposal.

Stack, Sir Lee (1868–1924) — Sirdar of the Egyptian Army, popular Governor of the Sudan. He is based in Khartoum, but has a residence in Cairo where he is often found. Stack is murdered on November 19, 1924 by Egyptian separatists in Cairo, near the British Residence.

Watson, Dr. Charles (1871–1948) — Founder and President of the American University in Cairo (AUC).

Williams, Valentine (1883–1946) — Special Cairo correspondent to the *London Times* newspaper. Sending regular reports on political unrest back to London by wire, Val is a keen reporter with a good eye for a story. He is an invaluable assistant for investigators, often able to supply the key bit of information they have missed. He is a regular at the bars at Shephard's, and is often found inspecting and photographing new acquisitions at the Museum. He frequently travels up the Nile to report on archaeological digs.

Zaghlul Pasha, **Saad** (1857–1927) — The main agitator for Egyptian self-rule throughout the early 1920's, he is Prime Minister of Egypt several times during that decade. He dies August 24, 1927.

Zakki Wissa Bey — A noted landholder in the Fayoum province. A farmer, oil baron, and amateur archaeologist, he is keen to show visitors around the district.

Lawrence of Arabia

Many Keepers and players will have seen the film of the adventures of "Lawrence of Arabia", the golden-haired, tall, heroic Englishman that led the Bedouin Arabs to victory over the **Turkish** army in the Great War. Peter **O'Toole** portrays Lawrence as a romantic, exotic figure, dashing handsome, troubled, and willing to sacrifice all for his cause.

The real Thomas Edward (Ned) Lawrence is slightly shorter than expected (5'6"), but is considered a hero during the 1920's. **Born** in 1888 in Wales (Great Britain),



the illegitimate son of a British lord and the governess of his daughters, Ned studied medieval architecture at Oxford University. He graduated with honors in history in 1910. A traveling fellowship in archaeology from Oxford allowed him to spend the next four years excavating and exploring Hittite cities in Iraq and the Sinai Peninsula of Egypt. An expedition in early 1914 appeared from the outside to be a scientific research **expedition**, but was in

fact a strategic and mapping **expedition** for the British War Office. When the Great War began in 1914, he joined the War Office as a cartographer, but became a lieutenant in military intelligence as an advisor on Arab affairs.

By 1916 he had become convinced that the Bedouin Arabs and Egyptian people could stop the advance of the **Turkish** army into Egypt and **Africa**, and he became advisor to Prince **Faisal**, son of Prince Hussein of Mecca. Joining the Arab army as a political and liaison officer, he became influential in the destruction of Turkish supply lines (by dynamiting the railroads) and in the uniting of the separate Arab and Bedouin clans into a united Arab nation. With the permission of the War Office he promised them self-rule if they won the war, and a vast sum of English gold sovereigns.

The victory of the Arab army over the Turks at Aqaba in 1917, planned and commanded by Lawrence, was instrumental in turning the tide of the Great War in the Middle East. Soon after, while reconnoitering in **Dara**, he was captured by the Turks and brutally tortured. This crippled **him** in body but not in spirit, and he pushed on with the Arabs, aiding them in the victory at Medina, until the war was almost over. He entered Damascus with the Arab army a few hours ahead of Lord **Allenby** and the British **Army**. Arriving back in England just before the armistice was signed, he refused all requests for interviews, even turning down a royal audience. (Keeper's note: Evidence has come to light recently that the legendary Australian Light Horse Regiment actually reached Aqaba before Lawrence and his force, but that this was **suppressed** by the British military.)

Despite his reluctance, Lawrence became a hero to the British and world public. News documentaries were made with the few photographs and **films** of him and screened in cinemas to packed audiences. People who had barely met him published biographies of his life and books entitled *With Lawrence in Arabia*. To avoid all the fuss he went into a self-imposed exile to write his memoirs (to be published as **Seven Pillars of Wisdom** in 1926).

He was lured back into the public eye in 1921 as an advisor on Arab affairs to Winston Churchill in **Cairo** during the negotiations on Egyptian self-rule. He can be found at Shephard's Hotel in Cairo between November 1921 and July 1922.

Returning to England—even more of a public figure with the press chasing him constantly—he enlisted under the name of John Hume Ross in the Royal Air Force. He was stationed at **Farnborough** Air Force Base until December 1922, when the press discovered him; the Air Force released him from service in January 1923, embarrassed at not having recognized him. Joining the Royal Tank Corps as a private in March 1923 under the name of T. E. Shaw, he was posted to Bovington Camp in **Dorset**, and owned a **small** cottage near the base. Investigators can find him here until 1925, after which he transferred to the Royal Air Force; he was sent to India in 1927. He was returned to England again in 1929 when rumors were spread that he was acting as a spy against the Soviet Union, and was based at the Cattewater Air Base near Plymouth from July 1929.

He never married, and lived alone for most of his later years in England. He was close friends with the novelists George Bernard Shaw, Henry Williamson and H. G. Wells. In addition to his memoirs, Lawrence completed and published (under pseudonyms) translations of *The Odyssey* by Homer, and *Forest Giant* by **Adrien le Corbeau**. Lawrence died at the age of 47 at the Bovington Camp hospital on 19 May 1935, from severe head injuries following a motorbike accident.

Lawrence's lasting legacy to the Egyptian people is self-rule, promised to them in 1917. It took until 1956 for this to finally become a reality, and for the last British troops to leave Egyptian and Arab soil.

Lawrence's knowledge of Arab affairs and Egyptian and Iraqi archaeology and history can make him an invaluable ally to investigators who encounter him during the 1920's. He has no particular knowledge of occult or Mythos matters, but has excellent contacts in Egypt in the royal family and among the army and government officers in Cairo.

THOMAS EDWARD (Ned) LAWRENCE (of Arabia), aka John Hume Ross, Tom E. Shaw; adventurer, archaeologist, diplomat, soldier, historian, pilot, author, spy; age 32 (1920)

STR 15 CON 10 SIZ 12 INT 16 POW 10
DEX 13 APP 12 EDU 18 SAN 50 HP 11

Damage Bonus: +1d4

Weapons: Pistol 85%, damage 1d10

Rifle 80%, damage 2d6 + 4

Fist 75%, damage 1d3 + 1d4

Knife 70%, damage 1d4 + 2 + 1d4

Machine Gun 65%, damage 2d6 + 4

Skills: Anthropology 60%, Archaeology 70%, Astronomy 40%, Credit Rating 90% (using real name only), Demolitions 60%, History 75%, Navigate 80%, Ride 65%, Track 70%; Languages: Arabic 90%, English 80%, French 70%, Greek 70%

The Bedouin of the Deserts

Beyond the fertile plains of the Nile Valley, Egypt is a land of desert. To the east of the river, the Arabian Desert stretches to the Suez Canal, the Gulf of Suez, and the Red Sea. To the west the river is bordered by the Libyan Desert and the Sudan (**Soudan**).

Constantly shifting fine desert sands, blown by winds that appear to rise from nowhere, cover any roads, tracks or buildings left unattended. The desert is a harsh land, a land of no compromise, a land of the wise or the dead.

Scattered throughout the deserts are small oases (singular: oasis). These are tiny pockets of green rarely more than three acres in size, surrounding a spring or well. Each oasis is the property of all desert dwellers, but is **tended** by a specific tribe of desert-dwelling nomads, the Bedouin. Wearing their traditional long white robes and turbans, the Bedouin can be a **terrifying** sight as they ride through the desert holding their rifles high and yelling fierce war cries.

Bedouin Life

The Bedouin are fiercely independent nomadic tribesmen. Numbering only 35,000 in the **1920's**, their **communities** are widely scattered, rarely entering cities or towns. Living all their lives in the deserts, they are wise to the changing patterns of the wind and sand, and navigate by the patterns of the dunes and the stars. They know the locations of all the main water sources and oases. They are hospitable and friendly to travelers, quickly coming to the aid of any lost in the desert, but **are** equally swift to deal death to those who pollute their water or insult their honor.

Each Bedouin tribe, or *qabila*, is headed by a sheikh. He is the law in all matters, and is obeyed totally by the people under his care. Most Bedouin are Mohammedan, but few adhere to the strict regime of prayer seen in the cities. Many also still worship the ancient spirits of land and of the stars. They follow a lunar calendar, and move their flocks of horses, sheep, goats and camels with the seasons.

Traveling when necessary between the oases, they carry everything they own on the backs of their camels. Material possessions **are** valued, but small. A woman's wealth is her bride jewelry, a treasure of intricately worked silver and beads added to by each generation and passed from mother to daughter. A man's wealth is his strength, his family, and his livestock.

A Bedouin Camp

Their encampments are clusters of large tents, each made from woven wool and cotton and intricately embroidered. Inside each tent the floor of the desert is covered by rugs and carpets of silk and wool, and embroidered sitting cushions are scattered around the sides.



Meals are eaten in the tents; the rich stews and roasted meats served in a common pot **are** eaten with sticky rice and flat breads of maize, held with the fingers. **If** any guest begins to show signs of being full and refuses food, the host breaks off a piece of bread, dips it in the stew and insists that the guest eats it. A special delicacy given to honored guests is the eyes of the sheep killed for the feast. These are lightly fried and served in a small bowl looking up at the guest. To refuse them is a great insult.

All meals **are** served with incredibly thick and rich coffee and equally strong **tea**. Both come in tiny cups the size of a thimble. These **are refilled** endlessly from the central pots of coffee and tea stewing on the fireplace in the center of the tent.

Women and men almost never share accommodations, there being separate men's tents (*selamlik*) and women's tents (harem). They eat separately, talk separately, and live separately, only coming together as husband and wife. Each Bedouin man may have many wives; his importance in the society is partially measured by the size of his harem as well as by the number of sons he has fathered.

Secrets of the Harem

Within the harem, the wives and daughters of the Bedouin live their own lives. They **are** totally covered when in public, their faces hidden behind black veils or by leather masks, but in the harem they dress in thin and revealing cotton, silk or linen trousers and skirts. The length of their

hair and the weight of silver in their jewelry **are** sources of great pride. Tattooing of the skin around the eyes and lips, and on the hands and feet is common. At special feasts this is accentuated by dark kohl applied to the eyelids, and red **henna** painted onto the hands and feet.

Old Beliefs

Many of the Bedouin **are** extremely superstitious and follow traditional magical ways. The **small** children all have tiny bags of herbs and oils tied around their **necks** to drive away evil spirits of death. The adults all carry charms and talismans to ward off illness and the evil eye. **They** have a passionate hatred for those who worship evil or **blasphemous** gods.

Personalities

TYPICAL BEDOUIN SHEIKH

STR 14	CON 16	SIZ 14	INT 16	POW 13
DEX 13	APP 15	EDU 12	SAN 65	HP 15

Damage Bonus: +1d4

Weapons: Rifle 80%, damage 1d6 + 2
 Knife 70%, damage 1d4 + 2 + 1d4
 Sword 70%, damage 1d8 + 1 + 1d4

Skills: Find Water 90%. Navigate 80%. Persuade 85%. Ride 80%. Tell Tall Tales 80%

TYPICAL BEDOUIN TRIBESMAN

STR 13 CON 14 SIZ 13 INT 13 POW 12
DEX 12 APP 13 EDU 9 SAN 60 HP 14

Damage Bonus: +1d4

Weapons: Sword 70%, damage 1d8 + 1 + 1d4

Knife 60%, damage 1d4 + 2 + 1d4

Rifle 60%, damage 1d6 + 2

Skills: Navigate 60%, Ride 60%

Scenario Hook: Encounters with Bedouin are always possible, should investigators find themselves lost or in trouble while traveling the trackless sea of sand. How the tribesmen treat the investigators is very much dependent on how the investigators behave! Perhaps elders in the community know old tales handed down by oral traditions for untold generations, or maybe they know charms and wards against dark gods.

Secret Groups

The plethora of magic and history in Egypt draws people from all over the world. Some of them are merely curious observers; others are searching for the secrets of ancient power and eternal life. Not all are madmen and women intent on world destruction: Some are merely satisfied with power over themselves and their neighbours. Others are groups devoted to fighting the power and corruption that other secret societies attempt to bring into this world.

Cairo houses representatives of the Golden Dawn, the Rechabites, and a strong Masonic Lodge. The Masonic Temple is opposite the Egyptian Museum in Cairo. It was designed by the same architect and built at the same time. Rumors abound that tunnels connect the two buildings, with secret ceremonies being held in the Museum after closing.

Cults

BROTHERHOOD OF THE BLACK PHARAOH

The Brotherhood are a group of wealthy Egyptians and Sudanese, most holding positions of power, who worship Nyarlathotep. Dedicated to bringing about his will on Earth, they are ruthless in their dealings with those who get in their way. They meet at irregular intervals to conduct rituals in the desert near the pyramids at Saqqara, and in the network of caverns below the Sphinx at Giza. The chief priest of the cult is Omar Shakti, a wealthy cotton farmer and landowner who runs a large property in the Fayoum. Associated cults: Starry Wisdom Sect, Brotherhood of the Beast. (Adapted from *Masks of Nyarlathotep*.)



TYPICAL BROTHER OF THE BLACK PHARAOH

STR 12 CON 14 SIZ 11 DEX 10 APP 6
SAN 0 INT 11 POW 10 EDU 1 HP 13

Weapons: Cult Club 55%, damage 1d8

Dagger 50%, damage 1d4+2

Short Sword 35%, damage 1d6+1

Garotte 20%, 1d3 choke per round, STR vs. STR to break free

Skills: Archaeology 5%, Astronomy 5%, Conceal 45%, Cthulhu

Mythos 35%. Hide 75%, Listen 55%, Occult 20%, Other Language (English) 15%, Sneak 60%. Spot Hidden 45%

Spells: Senior cult members know 1d4 spells related to

Nyarlathep

CHILDREN OF THE SPHINX

A sub-cult of the Brotherhood of the Black Pharaoh, the members of this cult are dedicated to recreating the ancient Egyptian gods on earth. A member of the cult undergoes a complex and hideous ritual in which his own head is severed and replaced with that of the animal icon of the Egyptian god he will represent. Once this ritual has been completed, he retains his human knowledge and will, while gradually gaining the powers attributed to the ancient god. He can no longer move around in the open unless he is masked. Some of the animal heads make this impossible.

Members are recruited from among the bored rich of Cairo, lured by the romance of the old gods and the promise of power. Many have been reported missing by their families; it is assumed by the police that they have left the country.

The Children of the Sphinx officiate at the ceremonies conducted by the Brotherhood of the Black Pharaoh beneath the Sphinx. Most of them now live in luxurious rooms that open off the tunnels below the Sphinx. These tunnels connect with the grotto in the Zoological Gardens at Giza. The animals used in their rituals are stolen from the Zoo, or are bought from hunters and trappers. (Adapted from *Masks of Nyarlathotep*.)

BRETHREN OF SETH

One of the oldest cults in Egypt, the Brethren of Seth claim to have originated in predynastic times. Their height was during the 21st Dynasty (1090-945 B.C.) at Tanis, when their priests became the pharaohs of Egypt. They claim the god Seth was once mortal, the son of the first pharaoh to unite Upper and Lower Egypt. He fought and killed his father, drinking his father's blood in his triumph. Ever after he was forced to continue this blood drinking.



The Brethren of Seth conduct ceremonies involving drinking the blood of sacrificed humans, sure that this act will prolong their lives if they are true to their god. They travel to a fallen temple beyond the pyramids each month for their ceremonies. The temple is surrounded by hidden pits full of venomous snakes.

The high priest claims to be the living Seth. He is ancient and deeply wrinkled, with eyes that have seen far too much of life. Some say that he is a vampire, older than Fennalik of Europe (see *Horror on the Orient Express*).

PETESOUCHI (pronounced peh-teh-SOO-kie)

The petesouchi are the descendents of the Egyptian worshippers of the crocodile god Petesouchos. Petesouchos was a blending of Sebek, the crocodile god of the ancient Egyptians, and the newer gods of the Greek inhabitants of Alexandria. Originally denizens of the swampy Fayoum district of the Nile to the south of Cairo, the petesouchi were shunned by the people of Alexandria, their worship and religion considered vile and unspeakable. The ultimate aim of their religion was to become one with their god. They achieved this through magical means, by the adaptation of a spell found in the *Book of the Dead*.



With the draining of their original home for farmland and the encroachment of towns, they have moved deeper into the remaining Nile swampland. Few of them remain now, their ramshackle villages scattered on hillocks through the fetid marshlands.

The petesouchi are also known as "crocodile men." In a manner similar to the deep ones, the petesouchi undergo a metamorphosis which begins at adolescence and slowly, agonizingly, changes every aspect of their body. Unlike deep ones, however, their final mature form is that of an enormous crocodile with human intelligence. Unable to communicate any more with other humans or even their own children, they remain in the area but are forever isolated from their families.

Locals and hunters stay well away from the marshes of the Fayoum; the mature petesouchi are expert at overturning the boats of the unwary and devouring the wriggling and screaming contents. Outsiders often comment on the oddity that locals never seem to be bothered by the crocodiles infesting the region.

Petesouchi children and adolescents appear totally human. Not all undergo the change; some remain entirely human. Others are only partly changed, having slightly scaly skin, elongated teeth, or webbed and clawed fingers. Petesouchi marry very young, at the first signs of puberty, and bear children before their change begins. The children are raised by those of their family who do not change fully. Those who remain unchanged speak a blend of Old Egyptian and Greek.

All petesouchi have a distinct dietary preference for fish. Much of the fish supplied to the Cairo markets is caught by them and then sold to others to transport to market.

PETESOUCHI. Crocodile Men

characteristics	rolls	averages
STR	5d6 + 12	29
CON	4d6 + 8	22
SIZ	4d6 + 15	29
INT	2d6 + 6	13
POW	3d6	10-11
DEX	2d6	8
Move 7/10 Swimming	HP 25	

Av. Damage Bonus: +3d6

Weapon: Bite 60%, damage 1d10 + db

Roll 60%. crushing damage 1d10 + 4 + db

Armor: 6-point hide

Skills: Glide Stealthily Through Water 80%, Hide 70%.

Overturn Boat 70%, Sneak 40%

Spells: Petesouchi with POW of 14 or more know 1d4 spells from the *Book of the Dead*.

Sanity Loss: 0/1d4 to see adult petesouchi; 0/1d6 to see transforming or partially changed petesouchi.

Investigator Organizations**SONS OF THE MAMLUKS**

Descendants of the medieval rulers of Cairo, this group of men is devoted to the extermination of those who bow to the Cthulhu Mythos. The presence in Cairo of a number of fragments of the *Al-Azif* keeps them constantly on the alert. They use whatever methods are necessary to thwart the worshippers of Mythos gods. They can be contacted through one of their members, Mohareb Todrus (see page 22), the owner of The Prophet's Grace, a coffee shop in the *Ezbekiya* district. They will assist investigators, but have a tendency to take over when things get too tough.

Magic in Egypt

Egypt is a country bathed in magical power since the earliest civilizations began. The first cultures had spells for all aspects of life and death. Simple charms and talismans used by the ancient Egyptians, such as the scarab charm, are still in use today. Every cab in Cairo has a scarab affixed to it, regardless of the religious beliefs of the driver.

Superstitions run deep in the populace. Ancient gods are given new names, and their ceremonies are updated to serve new religions, but they are still celebrated on the same days.

Much of the magic is based on "words of power." The ancient Egyptians believed that every being, both living and supernatural, possessed a secret name. The name of a man was as much a part of his being as his body or soul. Knowledge of that name and the speaking of the name aloud gave the speaker power over the being.

Egyptian magic was more religion than spellcasting. Spells in Egyptian magic are not so much spells as Europeans are accustomed to, but rather prayers and chants quite mundane in nature. Each one is quite long. Sources for spells are translations of the original documents, such as the *Book of the Dead*.

Magical Books

BOOK OF THE DEAD

This is the most famous of all the books of magic of ancient Egypt. It is not actually a book, but rather several **different** texts found on papyri in many of the tombs. Containing more than 180 spells, it provides all of the information necessary to perform a successful mummification and resurrection. Text and spells from the Book of the *Dead* and its two lesser companion texts, the Book of *That Which Is in the Underworld* and the Book of Portals, can be found in most of the tombs of ancient Egypt and many of the museums of the world. Many of the reproduction papyri sold to **tourists** contain **spells from** these books.

Spells include:

- "Causing a Shabti to do work for a Man" — Animates a golem-like shabti under the control of **the** spellcaster.
- "For going in and out" — Allows passage between the lands of the living and those of the dead.

"For driving off a crocodile" — Prevents and repels attacks by the petesouchi.
- "For having power over one's enemy" — Allows control over the named person.
- "For being transformed into any shape one may wish to take" — Allows a human to take on the form of an animal. Common animals include falcon, heron, phoenix, swallow, snake, and jackal. A variation of this spell is used by the Children of the Sphinx.
- "For being transformed into a crocodile" — **This** is the main magic used by the petesouchi.

The Book of *the Dead* includes complex spells and rituals for all stages of the resurrection of a corpse. These detail how all of the organs must be removed from the body at death. The body is then mummified, and the body and organs are placed in a tomb from which they travel separately into the underworld of the gods of the dead. The **reanimator** must then travel into this realm, reassemble the body, find and replace the soul of the dead (in the form of a scarab beetle that burrows into the body of the corpse) and bring both himself and the mummy back into the lands of the living again. The lands of the dead **are** populated by venomous snakes and scorpions, demons and evil spirits, and by the gods Osiris, Thoth, Ptah and Seth.

A resurrected person is indistinguishable from a normal human. Mummies **are** those who have been resurrected without their organs or a soul.

Spells involved in true resurrection include "For not letting the corpse perish". "**For** raising the corpse", and "For going out into the day." A classic Egyptian mummy can be reanimated by the use of the spell "Living after death."

MEDICAL SPELLS

The human body is divided into thirty-six parts, each having a specific god that guards it. In order to cure an affliction of that part of the body, one only has to invoke the god. These gods include Nu (hair), Ra (face), **Hathor** (eyes), **Anubis** (lips), and **Thoth, the god** that holds the body together.

There are many individual papyri of **spells in museums and libraries** in Egypt. Most **are** simple medical and healing spells. The papyri contain **the** words to be spoken to drive out the demons of disease, the prescriptions to be taken to heal the body, and instructions in the making of **charms** to ward off the disease demons. In most cases **the** shape of the **charm** reflects the shape of **the** organ to be healed. From the numbers of each charm found by archaeologists, ancient Egyptians appeared to suffer from a large variety of diseases of **the sexual** organs.

DREAM SPELLS

Papyri and spells to induce and interpret **dreams are** found in many Egyptian and Western museums. Egyptian magicians were able to provide specific **dreams** for their clients, by the inscribing of magical pictures and the speaking of magical words. This allowed the dreamer to converse with and petition the gods of Egypt. **Specific** gods have specific rituals. The pictures must be drawn in the blood of the animal sacred to that god.

The Hermetic Tradition

Hermetic magic originated in Egypt between 50 and 300 A.D. A blend of the occult knowledge of traditional Egypt and the new magics of **the Greeks** of Alexandria, it is said to have been created by **Hermes Trismegistos** ("thrice-great Hermes"), a Greek name for the Egyptian god Thoth. The original writings of the **Hermetics**, entirely in **Greek**, largely involve alchemical and magical rituals and spells. This is the origin of what is now considered "traditional" European magics, the spells of witches and warlocks, and the "science" behind the medieval alchemists.

In addition to spells and rituals, the works of **Hermes** provide a code for living, a Hermetic philosophy altered and adopted by **Aleister Crowley**, Samuel **Mathers**, Dion Fortune, and the Hermetic Order of **the Golden Dawn**. The Hermetic writings are also thought to be the inspiration for the traditions and rituals used in the late 1700's by **Cagliostro** to create Egyptian Masonry.

Copies of the works of **Hermes Trismegistos** may be found in Egypt in the libraries of Al-Azhar University, the Egyptian Museum, the Museum of **Greco-Roman** Antiquities at Alexandria, and the Coptic Museum in Old Cairo. Many other libraries **around** the world also have copies.

Gods of Ancient Egypt

"... mysteries older than the dynastic Egypt we excavate, and having a sinister relation to the persistence of abnormal, animal-headed gods in the ancient Nilotic pantheon."

The people of ancient Egypt worshiped a vast pantheon of gods. The names of the most important gods varied depending on the area—whether Upper, Middle or Lower Egypt—and each region also had its own local deities. The majority of gods are represented in anthropomorphic form, with the head of an animal and the body of a human.

To the people of ancient Egypt the gods were very real. They appeared in life in the forms of their priests, and in the pharaoh who was considered a "living god on earth." Animals that shared the same features as a god were considered sacred to that particular god; cats were sacred to and protected by Bast, falcons by Horus. When an animal symbol of a god died, it was mummified just as if it were a human, and then placed in the local temple dedicated to that god. This was considered to be a sacred duty; the offering brought the favor of the god upon the petitioner. To cut corners in the busy life of the richer Egyptians, it was possible to purchase pre-mummified animals just before entering the temple in order to offer them to the god inside. Many of the vendors of such offerings have been revealed in recent times as con artists; many animal mummies found in temples have been shown to be nothing more than a carefully sculpted and wrapped bundle of rags.

The **Theban** god cycle describes creation proceeding from eight primordial beings of chaos who inhabited the primeval slime. In Thebes, these eight are considered the children of Ptah. The four males are toads and the four females are snakes, forming the pairs of Nu and Naunet (primordial matter and primordial space); Kuk and Kauket (the illimitable and the boundless); Huh and Hauhet (darkness and obscurity); and Amun and Amunet (hidden and concealed ones).

The matings of the eight create the sun. Other offspring, the brothers Horus and Seth, constantly war for domination over the earth. The earth god, Geb, acts as a mediator, originally splitting the country between the brothers. Later he changes his mind and gives the whole of Egypt to Horus. Seth, furious with his brother, is driven into the underworld where he rules supreme. No direct mentions are made of Mythos gods in any ancient Egyptian temple or tomb. Some have theorized that the sun god **Aten**, worshipped by Akhenaten, is in fact the Mythos being **Azathoth**, but as yet there is no direct evidence.

Scenario Hook: The gods of ancient Egypt are the inhabitants of an unnamed city in the Dreamlands, entered from the waking world via the tunnels of the ghouls below the cemeteries of Cairo. The occupants of this city were Dreamed into the forms of the gods by the worship of the people of ancient Egypt. When Egyptian culture was at its height, the people of the city possessed the power of its gods. They fought great battles, enslaved other races, and created great monuments. As their worshipers have diminished in number, their powers have likewise faded. They now appear as animal-headed people going about their daily business in the city. The great wars they once fought are almost forgotten. Around their city lie the ruins of a much greater metropolis, unimaginably large, now abandoned to crumble and bury its once powerful treasures.

The Gods

Afura: Body of the sun-god of night.

Ami-ut: Dog-headed god of the dead.

Amset (Imset, Meset): One of the four sons of **Horus**. They protect the internal organs of the dead and are shown on all canopic jars. The others are Hap (ape-headed), Qebhsenuf (hawk-headed), and **Tuamutef** (jackal-headed). **Amset** has a human head.

Amun (Amen): The "hidden." An ancient god of Thebes. The powers of generation and growth in the unborn child. Husband of Amunet.

Amunet: The "concealed." Wife of Amun.

Amun-Ra (Amen-Re): **Theban** king of all the gods. Husband of Mut. A merger of Amun and the sun god Ra.

Ani: Moon god. Husband of **Anit**.

Anit: Moon goddess. Wife of AN.

Anqit: Local Elephantine goddess. Wife of **Khnemu**.

Anubis (Anpu): Jackal god of the dead. ~~Carer~~ for the souls of the dead. Brother of **Osiris**.

Apis: Bull god. The bull Hap is sacred to him.

Apep (Petous): Crocodile god. The arch enemy of all the sun gods.

Asten (Astis): Companion of Thoth.

Aten (Atum): Sun god of the 18th Dynasty. Replaced all the other gods for the reign of the "heretic" or "lunatic" pharaoh **Akhenaten**.

Ba: Ram god.

Baba (Beb): Son of Osiris, the first **born**.

Bakhis: Bull god. The bull **Bekha** is sacred to him.

Bas: **Marriage** and birth god. Represented by a laughing dwarf.

Bast: Cat goddess. Mother goddess of Bubastis, a city in the eastern delta. Goddess of joy.

Buto: Snake goddess of ancient Lower Egypt

Geb (Keb): Earth god. Husband of Nut.

Hap: Ape-headed son of Horus (see **Amset**).

Hapi: Nile god. He has the body of a man with women's breasts.

Hathor: Cow goddess. Goddess of joy and love. Sky goddess.

Hauhet: **Theban** goddess of obscurity. Wife of Huh.

Heqit: Frog goddess. One of the oldest mother goddesses of Egypt. Goddess of fertility and rebirth.

Horus (Her): Sky god and sun god. Falcon god. The son of **Isis** and Osiris. Son of Ra. Brother of Seth.

Hu: God of taste.

Huh: **Theban** god of darkness. Husband of Hauhet.

Imhotep: Architect from Memphis who was deified.

Isis: Goddess of Philae. Sister and wife of Osiris. Sister of Nephthys. Mother of Horns.

Isuaasit: Goddess of Heliopolis in ancient times.

Ka: Guardian of men.

Kauket: The "boundless." **Theban** goddess. Wife of Kuk.

Khepre: The primal state of being, the chaos that is to come. The scarab beetle.

Khensu (Khons): **Theban** moon god. Son of Mut.

Khnemu (Khnun): Ram god, one of the oldest gods in Egypt. He built the universe, made the gods, and made man from potter's clay. His wives were: **Anqit** and **Satit**. They are local to Elephantine and the first **cataract**.

Kuk: The "illimitable." **Theban** god. Husband of Kauket.

Maat: Goddess of the law and truth.

Mafft: Lynx god.

Mahes: Lion god.

Mehurit: Cow goddess. Sky goddess.

Memphis Triad: Ptah, Sekhmet, and Nefer-Temu.

Merit: Goddess of the flood.

Mer-Segerit: **Theban** goddess, a woman-headed serpent. Lover of silence.

Menhit: Lion goddess.

Mentu (**Mont**): War god of Thebes. Falcon god.

Menu (Min): Fertility god. God of travelers in the desert. Usually shown as a **priapic** man, or as an ithyphallus.

Meskhenit: Delivery room goddess. Worshiped by midwives and pregnant women.

Mnevis: Bull god. The bull Menu is sacred to him.

Mut: Mother goddess of Thebes. Wife of Amun-Ra. Mother of Khensu. Vulture goddess. Goddess of truth.

Naunet: The primordial space. Goddess of Thebes. Wife of Nu.

Nefer-Temu: Son of **Ptah** and Sekhmet of Memphis.

Nehebka: Serpent goddess.

Nekhebet: Mother goddess. Vulture goddess. Protector of pregnant women.

Nephthys: Goddess of the dead. Sister of Osiris, **Isis** and Seth. Wife of Seth.

Net: Mother goddess of **Sais**, in the Nile Delta. She has four aspects, and gave birth to the sun god while still a virgin.

Nu (Nun, Nenu): The primeval ocean; primordial matter. **Theban** god. Husband of Naunet.

Nut: Water goddess. Sky goddess. Wife of **Geb**.

Osiris: Originally the god of **vegetation**. Later god of the dead. King of the gods. Husband and brother of **Isis**. Brother of Nephthys, Anubis and Seth. Father of Baba and Horus.

Pahkit: Cat goddess.

Ptah: Leader of the gods at Memphis. God of art. Father of Nefer-Temu.

Ptah-Seker: Sun-god of night. God of death.

Ptah-Taten: Creator of that from which the world was formed.

Qebhsenuf: Hawk-headed son of Horns (see **Amset**).

Ra (Re): Sun god of Heliopolis. He took over the powers of all older sun gods, and was made leader of all the gods by his priests. All pharaohs in the later periods took the **proname** "son of Ra."

Rennit: God of the harvest.

Saa: God of touch.

Satit: Local Elephantine goddess. Wife of Khnemu.

Seker: Memphis god of death and the underworld.

Sekhmet: Memphis lion goddess. Goddess of war. Mother of Nefer-Temu.

Sept (Sothis): God of the dog star.

Serapis: Deified Apis bull. The god of death to the Alexandrian Greeks and Egyptians.

Serqit (**Selket**): Scorpion goddess.

Seshet: Goddess of literature and writing.

Seth (Set, **Setekh**, Sutek): God of Upper Egypt. Brother and killer of Osiris. Brother and enemy of **Horus**. God of war. God of the Semites. God of the impure. Jackal god. Husband and brother of Mephthys.

Shai: God of destiny and luck.

Suchos (**Sebek**): Crocodile god.

Taurit: Hippopotamus goddess. One of the oldest mother goddesses of Egypt.

Tem (**Atmu**): An ancient solar god. Head of the gods at Heliopolis.

Theban Trinity: Khensu, Amun-Ra and Mut.

Thoth: Ibis god. Baboon god. Moon god. The representation of the creator in the world. He invented mathematics and writing, and ordered the seasons. **Hermes Trismegistos** ("thrice-great **Hermes**") is a Greek name for Thoth.

Tuamutef: Jackal-headed son of Horus (see **Amset**).

Uatchit: The oldest mother goddess of Lower Egypt. Cobra goddess.

Un-Nefer: Hare god associated with Osiris.

Wep-Wawet (Upuatu): Wolf god associated with Anubis.

Historical Timeline

'The palaeogean tombs ... were hoary with a thousand years when Tut-Ankh-Amen mounted his golden throne in distant Thebes.'

Ancient and Medieval Egypt (to 1517 A.D.)

Before 3200 B.C.

This is the predynastic period. Egypt is made up of two kingdoms, Lower Egypt (the delta) and Upper Egypt (from Memphis [Cairo] to the First Cataract), each with its own ruler. Lower Egypt worships Horus and the snake goddess Buto. Upper Egypt worships Seth and the vulture goddess **Nekhabet**.

3200–2270 B.C.

The Old Kingdom. The uniting of Upper and Lower Egypt under one king (pharaoh).

3200–2780 K.C.

The time of the 1st and 2nd Dynasties and the pharaohs **Narmer** and Aha Mena (Menes). Their tombs are at **Abydos**. The first pictographs and writing. Cults of Apis and Ra begun.

2780–2270 K.C.

The Pyramid People. The 3rd to 6th Dynasties construct the first pyramids at Saqqara, Medum, Dashur, and Giza. The 5th Dynasty (2560–2420 B.C.) established the cult of Ra at Heliopolis.

2780–2720 B.C. 3rd Dynasty. **Zoser** moves capital to Memphis, builds step pyramid at Saqqara.

2720–2560 B.C. 4th Dynasty. Royal power expands. **Snefru** builds pyramids at Medum and Dashur. **Cheops**, **Chephren** and **Mycerinus** build pyramids at **Giza**.

2560–2420 B.C. 5th Dynasty. Height of the civilization and art of Egypt. Magnificent art and buildings at Abusir.

2420–2270 B.C. 6th Dynasty. The power of the **kings** becomes limited; some small states become independent. Trade with the upper Nile begins. Pyramids built at Saqqara.

2270–2100 B.C.

The Intermediate Period. The 7th to 10th Dynasties. At the end of the 6th Dynasty the pharaohs were weak in power. The 8th Dynasty remains at Memphis while the independent 9th and 10th Dynasties gain power at **Herakleopolis** and eventually rule all of Egypt.

2100–1700 B.C.

The Middle Kingdom. The 11th to 13th Dynasties.

2100–2000 B.C.

11th Dynasty. The rise of the **Theban kings**. Builders of the mortuary temple at Deir **el-Bahari**. By the end of this dynasty they overthrow the rulers at **Herakleopolis** and rule all of Egypt.

2000–1790 K.C.

12th Dynasty. The pharaohs **Sesosteris I–III** and **Ammenemes I–IV**. A prosperous time; most **towns** in Egypt have buildings of this period.

1790–1700 K.C.

13th Dynasty. Continuation of **Theban** rule. Most of the pharaohs are called **Sebek-hotep**.

1700–1555 B.C.

The **Hyksos** Period. Egypt declines in power during the 14th to 16th Dynasties (1700–1600 B.C.). The delta region is conquered by the **Hyksos**, a Semitic people known as the "shepherd kings." The south is ruled by the **&-scendents** of the **Theban** kings. The 17th Dynasty (1600–1555 B.C.), **Sekenyenre**, **Kemose** and **Amosis**, maintain the rule at **Thebes** and gradually push their power further north again.

1555–525 B.C.

The New Kingdom. Egypt becomes a great power during this period. Most of the tombs in the Valley of the Kings date from this time.

1555–1350 B.C.

18th Dynasty. These are the times of the pharaohs Amenhotep I-III, Thutmose I-N, Akhenaten (Amenhotep IV) and Nefertiti, and Tutankhamun. Egypt is united under the pharaoh, and tributes flood in from all surrounding countries. The capital at Thebes is moved by Akhenaten to Akhetaten, and the old gods are cast out in favor of the one god Aten. After his death, and the early death of his son-in-law Tutankhamun, the capital reverts to Thebes and the priests re-establish the old gods.

1350–1200 B.C.

19th Dynasty. The pharaoh Horemheb (general of Akhenaten) restores peace in Nubia. Rameses I and II and Sethos I and II wage great campaigns against the Libyans, Syrians and Hittites. The construction of the great temples at Kamak. The dynasty ends with a short period of anarchy.

1200–1090 B.C.

20th Dynasty. Seth-nakht restores peace within Egypt. Rameses III reigns peacefully and the priests of Amun become powerful. Rameses IV-XII are puppets to the priests of Amun, and Herihor, high priest of Amun, becomes pharaoh after the death of Rameses XII. The empire crumbles under his reign.

1090–332 B.C.

The Late Period. The 21st to 31st Dynasties.

1090–945 B.C.

21st Dynasty. The Tanites. A new dynastic line arises at Tanis under the leadership of Pinutem I, a Theban priest-king who marries into the Tanite dynasty. The empire decays even faster.

945–745 B.C.

22nd Dynasty. Kings of Libyan origin whose ancestors were mercenaries. The control of Egypt moves to Bubastis in the east delta region. The princes of the royal line are the high priests of Amun. Sheshonk I (Shishak) overthrows the Tanites, captures Jerusalem, and loots the temple of Solomon.

745–718 B.C.

23rd Dynasty. Little is known of these pharaohs, although they are based in Tanis. (Keeper's note: These are said to be the Keepers of the Ark of the Covenant at Tanis.) Tefnakhte fails in his attempt to take back Lower Egypt.

718–712 B.C.

24th Dynasty. Bocchoris, son of Tefnakhte, conquers Lower Egypt. Upper Egypt ruled by Ethiopia. Sabakon of Ethiopia captures Bocchoris and burns him to death. Ethiopia rules all of Egypt by 712 B.C.

712–663 B.C.

25th Dynasty. Nubian princes rule Egypt. Assyrians invade and drive back the Ethiopians. While the Assyrians are off raiding Babylon, Psammetichos of Sais repels the Ethiopians with the help of the Greek king of Lydia. Egypt and Ethiopia are divided from 633 onwards.

663–525 B.C.

26th Dynasty. Trade flourishes between Greece and Egypt. Egypt gains in strength and culture again.

525–332 B.C.

Persian domination of Egypt. The 27th to 30th Dynasties are mainly controlled by the Persians. Darius I builds the canal that links the Red Sea with the Nile River.

332 B.C.–395 A.D.

The Greco-Roman Period. Alexander the Great conquers Egypt in 332 B.C. He travels up the Nile to be crowned in the temple at Kamak, and then begins construction of Alexandria. Alexandria becomes the world center of Greek culture and commerce. On his death his empire is split between his generals. Ptolemy I (Soter I) rules as pharaoh in Egypt on behalf of Philip Arrhidæus (Alexander's imbecile half-brother) and Alexander II (Alexander's young son), and then in his own right. Ptolemy becomes king in 305 B.C. His successors, Ptolemy II-XIII, rule until 51 B.C. The Romans gain control of Egypt during the reign of Ptolemy V (203–181 B.C.). They allow the dynasty to rule with the guidance of the Senate in Rome.

51 B.C.

On the death of Ptolemy XIII his daughter Cleopatra becomes queen under the guardianship of the Roman Senate. Her brother Ptolemy XIV has her banished from Egypt. She returns with Julius Caesar, who assists her in regaining the throne. Ptolemy X N is drowned in the Nile.

41 B.C.

After the murder of Caesar in 44 B.C., Antony summons Cleopatra to Rome. He falls in love with her and is declared an enemy of Rome in 31 B.C. Antony and Cleopatra commit suicide in 30 B.C.

30 B.C.–395 A.D.

Egypt is a Roman province ruled by the Emperor in Rome and governed by his prefects.

110 A.D. The town of Elephantine founded by the Roman Emperor Trajan.

150 A.D. The astronomer and mathematician **Ptolemy** is working at Alexandria.

324–337 A.D. Constantine the Great gains control over Egypt and divides it into six provinces.

391 A.D. The Library of Alexandria is destroyed by fire.

39 — 39 A.D.

An intermediate period in Egyptian history.

619 A.D.

Egypt is invaded by the Persians. Alexandria is captured and ruled by Chosroes II.

622 A.D.

The prophet Mohammed flees from Mecca to Medina. The beginning of the Mohammedan calendar.

626 A.D.

Persians repulsed by **Heraclius**.

632 A.D.

Mohammed dies and is succeeded as ruler of Cairo by Abu Bekir. Bekir becomes the first caliph of Egypt.

634 A.D.

The Arabs begin their conquest of Egypt. Bekir dies and is succeeded by Caliph Omar.

640–1517 A.D.

The Middle Ages. Arab domination of Egypt.

640 A.D.

The remaining Byzantines are defeated at **Heliopolis** by the Arabs. Omar completes the destruction of the Library of Alexandria and the Serapeum.

641–642 A.D.

The fortress of Old Cairo is ceded to the Arabs. Fustat el-Kahira is founded. It becomes the center of military and government control.

645 A.D.

Alexandria is reclaimed by the Byzantine fleet.

646 A.D.

Omar recaptures Alexandria.

658–750 A.D.

Rule of the **Umayyad** dynasty, based in Damascus. Egypt is ruled by their governors. **Marwan II**, the last of the Umayyads, flees to Egypt in 744 A.D. He is murdered in 750 A.D.

750–868 A.D.

Rule of the **Abbasid** dynasty. Egypt ruled by Turkish governors that are frequently replaced. Arabic becomes the language of the fellahin.

868–905 A.D.

Rule of the **Tulunid** dynasty. The town of Cairo begins to take shape. Ahmad Ibn **Tulun**, governor of Egypt, declares himself to be an independent sultan. Many **mosques** are built.

905–935 A.D.

Egypt again ruled by the **Abbasids**. The **Fatimid** caliphs of **Qairawan** attack Egypt but are repelled.

935–969 A.D.

The Turk Mohammed el-Ikhshid, governor of Egypt, takes the throne, but has a troubled reign.

964–1171 A.D.

Rule of the **Fatimids**. Egypt conquered by the Fatimids.

969 A.D. The new capital of Cairo is founded.

970 A.D. Al-Azhar Mosque begun.

973–996 A.D. The **Fatimid** El-Aziz moves to Cairo and rules. He is a man of science and learning; in 988 he makes Al-Azhar Mosque a university also.

996–1021 A.D. **El-Hakim** succeeds El-Aziz. A man of incredible cruelty, he declares himself to be a reincarnation of the son-in-law of the Prophet and demands to be worshiped as a god. He disappears one night when riding in the Moqattam Hills, probably assassinated at the request of his sister. The rulers that follow are weak and ineffective.

1065–1072 A.D. The Nile flood fails for seven years. The starving people of Cairo loot the palace and library.

1074–1094 A.D. The Wizar (Vizir) **Badr** el-Gamali restores order, and governs with total power. Building begins on the walls and gates of Cairo.

1160–1169 A.D. Kurds attack Egypt. In 1166 the King of Jerusalem attacks Egypt. The **Wizir** Sharwar bums Fustat rather than let it be taken. Sharwar executed for showing uncertain loyalties.

1169–1171 A.D. **Saladin** rules on behalf of the **Fatimid** caliph and becomes sole ruler of Egypt on the caliph's death in 1171.

1171–1250 A.D.

Rule of the Ayubids.

1171–1193 A.D. **Saladin** moves his capital from Damascus to Cairo. Some say he brings with **him** the original manuscript of the *Al-Azif*. **Shortly** after his arrival a massive earthquake **destroys** much of the remains of Fustat and severely damages Cairo. Saladin's palace is undamaged.

1250–1382 A.D.

Rule of the **Bahrte mamluks**. The **mamluks** were originally the slaves of the caliphs. In the space of 132 years there are twenty-five sultans. They include **Beybars** (reigning from 1260-1277), **Qalaun** (1279-1290), **Mohammed en Nasir** (1293-1340), and **Hasan**, who was assassinated in 1361.

1303 A.D. During the reign of En Nasir another earthquake hits Cairo. Much of the medieval town is destroyed.

1382–1517 A.D.

Rule of the Circassian **mamluks**. A Circassian slave, **Barquq**, treacherously takes the throne from the great-grandson of En Nasir. His successors include **Farag** (1399-1412), **Sheikh el-Muaiyad** (1412-1421), **Bars Bey** (1422-1438), and **Kait Bey** (1468-1496). El-Muaiyad passes laws that decree that Christians and Jews must only wear certain colors of clothing, and that they wear five pound wooden crosses or balls around their necks.

1400 A.D. **Gharkas el-Khalili**, master of the horse to **Barquq**, founds the Bazaar of Khan **Khalili**.

Modern Egypt

1517–1930 A.D.

1517–1798 A.D.

In 1517 Egypt becomes a Turkish pashalik. It is ruled by Egyptian pashas, but all new laws must be approved by a council of the twenty-four mamluk beys that govern the provinces. The beys collect the taxes for their Turkish rulers, but pay them little more than lip service.

1798–1801 A.D.

French rule in Egypt. Napoleon **Bonaparte arrives** in Alexandria on 1 July 1798. His plans are to conquer Egypt and thereby block English trade from India. Alexandria is taken on July 2, Cairo is captured by September 25, and Upper Egypt is his by May 1799. He leaves for France again in August 1799. His governor of Egypt, **Kleber**, is assassinated in Cairo on 14 June 1800. The British army marches to Cairo in September 1801. The French are forced to leave Egypt or die. During the French occupation of Cairo Napoleon's headquarters are in the Palace of **Alfi Bey**. This later becomes the site of **Shepherd's Hotel**.

1801–1882 A.D.

Muhammed Ali and his family rule Egypt.

1801–1854 A.D.

The rule of **Muhammed Ali**. **Ali becomes** pasha when the Turkish governor is expelled following the French invasion. He takes possession of the Citadel of Cairo in 1805. His army defeats the British at Rosetta and Alexandria, forcing them to abandon Egypt. In 1811 he invites the **mamluk** beys to Cairo and **has** them assassinated by his Albanian troops **as** they travel up the road to the Citadel. He declares himself khedive (ruler) of Egypt. The Sultan of Turkey makes **Ali** and his successors the hereditary rulers of Egypt in 1841. **Ali** dies on 2 August 1848. He is succeeded by his grandson **Abbas I**, who rules until his own death in 1854.

1854–1863 A.D.

Sa'id, **Ali's** fourth son, becomes khedive. He completes the railways from Cairo to Alexandria and to Suez. He supports the construction of the Suez Canal.

1863–1879 A.D.

Ismail, the grandson of **Ali**, becomes khedive. He gradually works to gain **as** much of Egypt in his own name **as** he can, eventually owning 20% of all the arable land in Egypt. His mismanagement results in Egypt owing a huge debt to the **Porte** (the Turkish government). He is forced to resign and hand over all his assets to the state in 1878 and is deported to Constantinople.

1869

Suez canal opened.

1879 A.D.

Ismail's son, **Taufiq (Tewfiq)** succeeds his father as khedive.

1881 A.D.

A military revolt takes place in Cairo. They demand the removal of Europeans and Turks **from** Egypt and besiege **Taufiq** in his palace. **Taufiq** appoints **Sherif Pasha** prime minister, but he resigns in 1882 and is replaced by **Mahmud Pasha**, with **Arabi Bey** as his war minister.

1882–1919 A.D.

The beginning of the British era in Egypt.

1882 A.D.

British and French fleets take Alexandria, and **Arabi's** army is captured by the British. **Arabi** is exiled to Ceylon.

1883 A.D.

British rule in Egypt. **Sir Evelyn Baring**, later **Lord Cromer**, is appointed Consul General of Egypt. Nubian rebellion in the Sudan led by the **Mahdi (Muhammad Ahmad)** defeats the Egyptian army stationed **there**.

1884–1886 A.D.

Attempts **are** made to retake the Sudan, but they fail. The British concentrate instead on strengthening their control over Egypt.

1887 A.D.

The Suez Canal is declared neutral and opened to shipping of all nations.

1892 A.D.

Taufiq dies and is **replaced** by his son Abbas II. He is controlled by the British.

1896–1898 A.D.

Sir Herbert Kitchener (later General and then Viscount Kitchener) retakes the Sudan. It is placed under the **control** of Lord **Cromer**, the British **Governor** General to Egypt.

1902 A.D.

Aswan Dam completed.

1906 A.D.

Saad Zaghlul Pasha becomes Minister for Education.

1910 A.D.

Zaghlul appointed Minister of Justice.

1912 A.D.

Zaghlul resigns from ministry.

1913 A.D.

Zaghlul elected to **Legislative** Assembly. He becomes more nationalistic.

1914–1918 A.D.

The Great **War**. Turkey attempts to retake Egypt and Palestine, and is eventually repelled by a combined army of Arabs. Egypt **officially** becomes a British protectorate.

1916 A.D.

Sir Reginald **Wingate** appointed British High Commissioner to Egypt. He succeeds Lord Cromer.

1919 A.D.

Egyptian nationalist fervor begins, led by Zaghlul Pasha. In May Lord Edmund **Allenby** becomes British High Commissioner to Egypt. Zaghlul exiled for **first** time from Egypt (he is sent to Malta).

The 1920's**1920 A.D.**

Street marches monthly in all cities in Egypt calling for independence from Britain.

July 30. Anarchists tried **and** found guilty. They are hanged.

1921 A.D.

February. The **Milner** Report, **recommending** the end of Egypt's protectorate status and the start of negotiations toward a **treaty** of alliance, published.

March 12. Winston **Churchill** arrives to negotiate independence.

May 24. Riots in Alexandria and Cairo.

May 25. Europeans burned alive during riot.

May 27. Many **fires** burning at Alexandria.

May 28. Quiet restored again.

October 3. Locals rise up in arms at **Darfur** in the Sudan. **A** British officer and a European civilian **are** killed.

December 24. Sultan Fuad confers the Order of the Nile on **Miss Ellgood**.

December 27. Zaghlul Pasha **arrested** for inciting riots. Riots spread even faster, troops **are** called out.

December 29. Eleven natives killed by **troops** during riots.

December 31. Order restored.

1922 A.D.

The United States sets up a legation (embassy) in Cairo headed by Dr. M. Howell. Zaghlul allowed to return to **Egypt**.

January 31. Plot against minister revealed.

February 20. Mr. Jordan, a New **Zealander**, killed in Cairo.

February 21. British officials murdered.

February 22. A ban is announced on the carrying of arms by all Egyptians. Foreigners **are** exempted.

February 28. Egypt is recognized as an independent sovereign state by the British.

March 4. Riots in Cairo following new ministry appointments.

March 7. Cairo faces a severe water shortage. Rationing is invoked.

March 10. A plot against the Premier is uncovered.

March 11. Mohammedan women march through the streets demanding independence.

March 18. Prince Fuad is crowned King Fuad of Egypt.

April 11. A British deserter and five Russians are hanged for robbery and murder.

May 26. Major Cave of the British army is assassinated.

June 29. Nineteen foreign officials **are** dismissed.

July 15. Fourteen worshippers are killed in a Cairo mosque.

July 26. An Egyptian princess elopes with the **Wizir**.

August. Zaghlul is **permitted** to return from exile.

August 15. A British family is attacked in Cairo.

November. The opening of the tomb of Tutankhamun.

December. Professor W. **Robson**, attached to AUC, is killed by an unknown assassin.

December 23. Zaghlul exiled again, this time to the Seychelles.

December 30. Martial law is invoked in Cairo.

1923 A.D.

Following an unspecified scandal, Egypt withdraws its recognition of Mr. A. **Smirnoff**, a Russian diplomat.

January 1. An anonymous note to the King regrets the murder of **Prof. W. Robson**.

January 6. Revolvers are issued to all British subjects in Cairo.

March 6. Bombs thrown in Cairo.

March 31. Lord **Carnarvon's** illness is announced to the general public. On his death a few days later rumors begin about the "curse of the pharaohs." Many collectors of Egyptian artifacts donate them to museums to avoid the curse.

April 13–May 2. Howard Carter is ill.

April 19. Publication of the constitution of Egypt.

April 21. A plot to murder an Englishman in Cairo is uncovered. Payment for the planned deed was £15.

May 7. Egyptian women march through the streets calling for freedom from Mohammedan law and England.

May 26. One of the princes **marries** an English girl.

September 12. Howard Carter states that it will take at least two more years to clear Tutankhamun's tomb.

September 14. Zaghlul returns to Cairo and is elected Prime Minister. His **party** contests the results.

September 22. Tutankhamun's tomb reopened for the season. More treasures are found.

1924 A.D.

January. Results of September elections are finalized. Zaghlul is **confirmed** as Prime Minister.

January 8. Howard Carter ill again.

February 14. The golden coffin of Tutankhamun is exposed in a "blaze of light." The sarcophagus is resealed, and Carter declares that no more work will be done until next season.

February 18. Accusations are made that Carter has taken or hidden some of the items from **the** tomb for his own benefit. He denies the rumors.

February 22. Egyptian government revokes Carter's exploration license and takes control of the tomb. Lady **Carnarvon** is offered the license.

February 27. Riots at Alexandria; a factory is seized.

March 8. The tomb of **Tutankhamun** is **reopened** with a ceremony. Carter is still **funing**.

March 19. Street celebrations **mark** the opening of parliament in Cairo.

April 2. Material taken **from Tutankhamun's** tomb to England by Howard Carter and Lord **Carnarvon** is returned to **Egypt**.

May–July. Tutankhamun's tomb is closed. No work has been done inside since the official reopening in March.

May 21. Prince Said **Halim** returns to Egypt in disgrace following misbehavior in London and Paris.

July 14. Zaghlul is shot by a student. The wound is not serious.

August. Rising tensions in the Sudan cause British warships and troops to be placed on standby. They restore order in the Sudan.

August 25. The reopening of Tutankhamun's tomb is expected shortly.

September. Egyptian army riots at **Atbara** barracks.

September 17. Howard Carter agrees to continue the excavation of the tomb. Work is delayed until January.

September 24. Zaghlul travels to London. An attempt is made on his life, but he is not hit. He returns to Cairo again on October 9.

October 28. Zaghlul announces his intention to resign as Prime Minister.

November 18. Students demonstrate in the streets of Cairo.

November 19. Sir Lee Stack, Governor of Sudan is assassinated. Egyptian detachments are withdrawn from the Sudan. Zaghlul resigns as Prime Minister after Stack's funeral.

December 1. Troops mutiny in the Sudan. **Three** doctors are killed.

December 2. Students return to school, but are still unruly throughout December. **Fifty** are expelled.

December 8. The Sudanese mutiny continues. **Three** officers are shot. Guards are placed on the royal family.

December 19. Hassanein Bey, a noted Arab explorer and diplomat, changes alliances. He switches from the **American** to the British Legation in Cairo. No reason is given.

December 31. Restrictions are placed on students to maintain order.

1925 A.D.

January 3. Students march in Cairo.

January 7. Carter is in dispute with Egyptian **government** over methods used in the tomb.

January 15. Tomb of **Tutankhamun** to be reopened by Carter. See May.

January 30. Assassins are arrested on suspicion of killing Stack. More are arrested throughout February and March. Nine finally stand **trial** in May and are convicted in June. Eight are given the death sentence.

May 2. Carter finally reopens tomb and resumes search.

May 21. Lord **Allenby** resigns his position. He is succeeded in October by Lord George Lloyd.

1926 A.D.

January 1. The new year is welcomed in on the top of the Great Pyramid at Giza by a party of American tourists from the SS **Empress** of Scotland.

January 1. Former ministers are to be charged with complicity in the murder of Stack.

January 4. The gold funerary mask of Tutankhamun is calculated to contain £40,000 worth of gold.

May. Dr. Gwrg A. Reisner returns to the pyramids to continue his excavations as leader of the **Harvard/Boston** expedition.

May. General elections held. Zaghlul announces he will not accept leadership. He changes his mind and becomes Prime Minister again. He is eventually replaced by Adli Yeghen.

June 5. Reisner discovers the mummy of "the mother of **Cheops**" in a tomb at the base of the pyramid of Chwps.

August 17. All foreign legations are ordered to reduce the size of their staffs in Cairo.

August 19. Ministers in the Egyptian government are ordered to refund all claims for expenses.

October 30. Howard Carter begins the winter season at the tomb of Tutankhamun.

1927 A.D.

The directors of the Berlin Museum deny that Professor Borchardt (attached to the museum) stole a bust of Queen **Nefretete**. It is later discovered that the allegations were made by the Egyptian Finance Minister after he had been slighted by Borchardt.

A Soviet ship, the **Tchitchern**, is seized by customs at Cairo in retaliation for the impounding of the Egyptian freighter **Costi** at the port of Odessa.

Yeghen resigns as Prime Minister and is replaced by **Sarwat** Pasha.

January 1. The last of the murderers of Stack are executed.

March 7. A large jewel robbery occurs in Cairo.

May 6. The American ambassador, Dr. M. Howell, resigns.

May 20. Reisner discovers the tombs of the children of Chwps.

June. Relations become strained between Cairo and Britain over power of Britain in Egypt.

July 3. Howell attacks the Egyptian government over the freedom of availability of whiskey in Cairo.

July 5. King Fuad visits England to defuse tensions. A draft treaty between England and Egypt is proposed.

July 7. Howell holds a "dry" guildhall banquet. Donates £1000 to the poor of Cairo.

July 27. Howell **arrives** back in America.

August 12. A party of American students is detained in quarantine for a week on suspicion of carrying an unspecified "plague." They are released, still in quarantine, and must report to the Ambassador daily.

August 23. Zaghlul Pasha is dead.

November 24. A partial eclipse of the sun occurs in Cairo from 9:30 a.m. to sunset. Half the sun is obscured all day; the city feels cold and alien.

1928 A.D.

A fire breaks out on a tourist train. No one is injured, but three of the baggage cars are totally destroyed.

February 10. The foundation stone for the new buildings for **Cairo** University is laid.

March. **Sarwat** Pasha resigns. Mustafa **en-Nahas** Pasha becomes Prime Minister March 16.

March 9. **Mr.** F. M. Gunther, the new U.S. minister to Egypt, arrives.

April 7. A French savant, Dr J. C. **Mardrus**, predicts disaster if the tomb of Hotep is opened.

May 20. King Fuad announces a new plan of **modernization** to commence in Cairo.

June 24. En-Nahas' **ministry** is dismissed. Mahmud Pasha is appointed Prime Minister.

July 5. Prince Mohammed Ali visits Australia.

July 19. Parliament is suspended for three years. The King will rule with the advice of his ministers.

October 8. Aviators find demented hunters in the desert, stalking each other with rifles.

November 12. A boat overturns in the Nile. Twenty-eight schoolgirls drown.

1929 A.D.

Hassanein Bey is made Inspector General of the Egyptian government.

January 29. An arbitration treaty is set up with the U.S. government.

March 18. The British Museum returns the last of **Tutankhamun's** treasures to Egypt.

April 14. The treasures of **Tutankhamun** are finally on display in the Egyptian Museum in Cairo.

April 28. Two doctors, Dr. Madden and Dr. Thompson, are found dead in separate incidents. Similarities are noted in the circumstances of their deaths.

April 29. Dr. Madden is found to have died from a nervous breakdown.

May 11. Satisfactory agreement is reached between Egypt and Britain over the use of Nile water.

June 26. The Prime Minister of Egypt, **Mahmoud** Pasha, visits England.

July 16. King Fuad visits England.

July 25. Lord Lloyd resigns his position and returns to England. He claims he was "invited to leave" due to differences with the government. The leader of the nationalist party rejoices.

August 28. Sir Percy **Loraine** leaves England to take up the post of British High **Commissioner** in Egypt.

September. British authorities in Cairo seize copies of a book by Dr. M. Howell, the former American ambassador, as they consider it to be damaging to their image in Egypt.

1930 A.D.

April 23. Nile boating disaster. A pleasure cruiser capsizes killing twenty holiday **makers**.

May 16. Outbreak of bubonic plague in Cairo. **Thirty** infected so far. Doctors fear an epidemic.

June 18. The Cabinet of Ministers reporting to the King resigns.

Glossary

'From my smattering of Arabic I judged that they were discussing my ... performances.'

alatiya – musicians

asr – afternoon

awalim – female singers

baksheesh – tip, gratuity, usually a few **milliemes**

bir – well (water)

canopic jar – jar used for storing the internal organs of the deceased. These are placed separately in the tomb next to the body.

cartouche – (French borrowing) oval containing hieroglyphs, usually a name

darabukka – funnel-shaped drum

dervish – member of a Mohammedan sect who achieves rapture through dance

djinn – magical spirit or demon servant of Arab mages

duhr – midday

effendi – Turkish title of respect, especially for government officials and members of learned professions

ell – Arabic unit of measurement equal to **0.58** meters or **22.84** inches. The ancient word for the ell was the *qulhulu*.

fellahin – native Egyptian peasants

fellucca – typical Nile sailing boat

fiqh – recognition; the science of law in el-Islam

ghawazia – female (belly) dancers

goza – water pipe specifically for smoking hashish

ghoraz – hashish den

hanafiya – fountain for ritual washing before prayer

harem – women's quarters

hookah – water pipe used for smoking tobacco or hashish

huwa – jugglers

ijaza – subject qualification

isha – nightfall

kanaka – coffee pot

kiswa – holy carpet

latafeyah – narrow **street** protected from the sun by cloth awnings stretched between upper stories of the building each side. Common in market districts.

lebbakh – big spreading tree; member of the acacia family

liwan – halls used for prayer

ma'assil – sticky blend of chopped tobacco, fermented with molasses. Its oversweet odor is a sure sign that a qahwa is nearby.

maghrib – a little after sunset

mankeleh – popular Egyptian game

markub – red leather shoes worn by Egyptians

moka – rich, aromatic **chocolate**-flavored coffee

muezzin – the crier who calls the faithful to prayer five times a day

qahwa – coffee shop

qahwagi (also kahwegee) – coffee shop proprietor

qirat – **1/32** of an ell.

qulla – large pottery vessels for storing water

rifaiya – snake charmers

riqq – tambourine with bells

riwaq – students' or priests' accommodations

sahleeb – tea made from dried orchids and hibiscus flowers and topped with **cream** and chopped nuts

sahn **el-gami** – mosque courtyard

salat – prayer

saqiya – windlass; handle on a well

scarab – carved figure of the scarab beetle. The scarab symbolizes the heart and soul of the deceased.

selamluk – men's quarters

shabti – small pottery figurine, usually of a servant. Designed to accompany the deceased into the afterlife, where it will continue to serve him.

Shahadet el-alimiya – diploma of learning

Shahadet et **Takhassus** – diploma of specialization

sharia (also shara) – street of; (capitalized) holy law of el-Islam

sheesheh (also **nargeeleh**) – water pipe also referred to as the hookah, used to smoke all sorts of substances

sikka – covered street

stela – pottery or stone tile used to record affairs of the court or a household. The equivalent of a memorial **notepad**.

subh – daybreak; first light

tabl baladi – a type of drum

tarbouch (tarbush, tarbrush, fez) – red felt hat worn by Mohammedan men in Egypt. **A** Turkish custom, it is replacing the more traditional turban.

Wafa – festival of the Nile flood

weleka – large open space in the courtyard of a house

zembr – oboe-like instrument

ziker – dance of the dervishes

zumarra – double flute

English to Arabic

airplane – **taiyara**

afternoon – bad **ed-duhr**

American – marakani

aniseed – yansun

backgammon – **tawla**

beer – bira

bicycle – agala

blacksmith – **haddad**

blood – **damm**

boat – filuka

book – **kitab**

bookseller – kutbi

bottle – qizaza (water bottle - qulla)

brandy – araqi

broken – maksur (to break – **kasar**)

breakfast – futur

bury – dafan

butcher – gazzar

camel – gamal

camel driver – **gammal**

cards – kutschina

carpet – siggada

castle – qasar

cave – **maghara**

cemetery – quarafa

cheap – **rakhis**

cholera – hawa el-asfar

church – **kinisa**

clothes – hudum

cognac – kunyak

confectioner – halawani

consulate – qonsulato

convent – deir

cow – baqara

crocodile – tirnsah

dagger – **khengar**

dance – **raqs**

dead – **maiyyit** (to die – **maat**)

deaf – **atrash**

deceitful – khain

deep – **ghamiq**

desert – gebel

diarrhea – ishul

difficult – sa'b

doctor – **hakim**

dog – kalb

donkey – humar

door – bab

dragoman (tour guide) – turguman

east – sharq

egg – **beida**

Egypt – Masr

enough – **kifaya**

entrance – dhukul

envelope – zarf

evening – ashiya

falling star – **nigma zariq**

fee – ugra

fenugreek – helba

fever – **himma**

fire – **nar** (big fire – **hariqa**)

fish – samaka

fog – shabura

foot (leg) – **rigl**

forbidden – **mamnu**

foreign – **gharib**

fortress – qal'a

fountain – sibil

friend – **habib**, sahib

garlic – tum

gate – bab

ghoul – **ghul**

gift – baqshish

ginger – **ganzabeel**

gold – **dahab**

grave – **turba**

green – **akhdar**

grocer – baqqal

guide – **dalil**

gun – bunduqiya

gunpowder – barud

harbor – **mina**

home – **beit**

honest – **amin**

horse – hosan

hospital – isbitaliya

hotel – **locanda**

hungry – **ga'an**

ill – **aiyan**

immediately – **halan**

island – **gezira**

kill, to – **mauwit**

king – **malik**

knife – **sikkina**

lady – sitt

lake – birket

lamp – lamba

large – kebir

lazy – kaslan

letter – gawab

light (bright) – **nur**

locomotive – wabur

luggage – afsh

lunch – ghada

mad – **magnun**

madhouse – muristan

man – ragil

market – bazaar, suq

meat – **lahm**

medicine – dawa

midday – **duhr**

midnight – nuss el-leil

mistake – **ghalat**

money – **fulus**

money-changer – **sarraaf**

moon – **qamar**

moon, full – **badr**
 moon, new – **hilal**
 morning – **subh**
 mosque – **gami**
 mosquito – **namusa**
 motor car – **utomobil**
 mountain – **gebel**
 news – **khobar**
 newspaper – **gurnal**
 night – **leil**
 north – **bahari**
 nothing – **ma fish**
 oasis – **wah**
 obelisk – **misalla**
 outside – **barra**
 pain – **waga**
 passport – **bassaborto**
 perhaps – **balki**
 please – **min fadlak**
 poison – **simm**
 police – **bolis**
 postcard – **tazkaret busta**
 post **office** – **busta**
 pretty – **kwaiyis**
 pyramid – **haram**
 railway – **es-sikka el-hadid**
 rain – **matar**
 razor – **mus**
 revolver – **fard**
 roast – **shawa**
 robber – **harami**
 rope – **habl**
 ruin – **kharaba. birba**
 scholar – **alim**
 scorpion – **aqraba**
 snake – **tiban**
 servant – **khaddam**
 ship – **markab**
 shoot – **darab**
 silk – **harir**
 Sir – **khawaga, afandi**

sister – **ukht**
 sleep – **nam**
 soldier – **askari**
 south – **qibli**
 star – **nigma**
 steamship – **wabur**
 stone – **haga**
 strange – **agib**
 stupid – **balid**
 sugar, a dash of – **arriha**
 sugar, medium – **mazbut**
 sugar, with extra – **ziyada**
 sugarless – **saada**
 sun – **shams**
 tea – **shay**
 teacher – **muallim**
 telegraph – **tilighraf**
 telephone – **tilifun**
 telescope – **naddara**
 tent – **kheima**
 thirsty – **atshan**
 tobacco – **tumbak**
 today – **en-nahar-da**
 tomorrow – **bukra**
 town – **rnadina**
 tree – **shagara**
 tribe – **qabila**
 true – **sahih**
 ugly – **wihish**
 untruthful – **kaddab**
 vainly – **balash**
 valley – **biban**
 violent – **shidid**
 waiter – **sufragi**
 war – **harbw**
 warehouse – **khan**
 water – **moiya**
 week – **guma**
 west – **garb**
 when – **imta**
 where – **fein**

whip – **kurbag**
 wind – **hawa** (hot wind – **khamasin**)
 woman – **mara, hurma**
 year – **sana**
 yesterday – **imbarih**

Phrases in Arabic

Beat him! – **Idrabuh!**
 Be silent! – **Uskut!**
 Bring dinner. – **Gib el-akl.**
 Can't you see him? – **Ma tesh-fuhsh?**
 Come here. – **Ta'ala hina.**
 Does this train go to Cairo? – **El-qatre di raih ala Masr?**
 Don't be angry. – **Ma tiz alsh.**
 Don't laugh! – **Ma tidhaksh!**
 Do you speak Arabic? – **Titkallim arabi?**
 Drink some coffee. – **Ishrab qawha.**
 Entrance forbidden – **ed-dhukul mamnu**
 Guide me. – **Waddiii.**
 Give me the money. – **Hat el-fulus.**
 Halt! – **Uqaf!**
 Have you loaded the pack animals? – **Shaddeitu?**
 He has sunstroke. – **Esh-shams darbetuh.**
 Here is my passport. – **Aho el-bass-aborto bitai.**
 He went out. – **Tili.**
 I am under your protection, save me! – **Ana fi ardak!**
 I can't find him! – **Ma alqahsh!**
 I can't sleep. – **Ma baqdarsh anam.**
 I don't know. – **Manish.**
 I have no money. – **Ma andish fulus.**
 I have lost my book. – **Daiyate ki-tabe.**
 I have been looking for you all day. – **Dauwarte aleik tul en-nahar.**
 I know him. – **Barafuh.**

In the name of God the compassionate and the merciful – **Bi-smi-llah i-r-rahman i-r-raheem**

Is the master at home? – **El-khawaga guwa?**

It is dark! – Ed-dinya **atma!**

It is hot! – Ed-dinya **harr!**

It is no use! – Ma yinfash!

Kill him! – Mauwituh! (also "I have killed him.")

My house is your house. – Beiti beidak.

Praise be to God! – El-hamdu **li-llah.**

Quick! – Yalla!

Run! – Igr!

Shut the door! – **Iqfil** el-bab!

Take care. – **Khalli** balak.

Take it away! – **Shiluh!**

Thank you. – **Kattar** kheirak.

That doesn't matter. – Ana ma-li. (inta maluk)

That is too expensive. – Di ghali ketir.

The door is shut! – El-bab **maqful!**

The fire burns. – En-nar beyula.

They have buried him. – Dafanuh.

What do you wish to buy? – **Auz tishtiri** ei?

What's happened? – **El-khabar** ei?

What's that called in Arabic? – **Is-muh** ei bil-arabi?

What is your name? – **Ismak** ei?

What time is it? – **Es-sa'a** kam?

When does the steamer arrive? – El-wabur **yusal** imta?

Where is the toilet? – El-kanif fein?

Which way to the hotel? – **Sikket** el-locanda min **ein?**

You haven't paid yet! – Lissa ma dafatish!

You're late! – **It-akhkhart!**

You lied to me! – **Inta** kidibt!

Arabic Proverbs

He who has burned his mouth with milk blows on ice cream.

The understanding of an Arab is in his eyes.

Open up your door to a good day, and prepare yourself for a bad one.

He who speaks the truth had better have one foot in the **stirrup**.

Patience, my friend, is the key of paradise.

Nobody but the one who is **carrying** the load knows how much it weighs.

To him who has no teeth left Allah gives dry beans to eat.

If a man puts a cord around his neck Allah will provide someone to pull it.

The **barking** of dogs does not hurt the clouds.

The camel driver has his plans, and the camel has his.

Hearts are depositories of secrets; lips **are** theu locks and tongues **are** their keys.

Think of the going out before you enter.

The days has its eyes, the night has its ears.

The hand that you cannot bite, kiss.

May Allah protect me from my friends; my enemies I can handle.

A small date stone props up the water jar.

Catch the halter rope and it will lead you to the donkey.

If a light serves to see, it also serves to be seen.

A dog cannot bite when it has a bone in its mouth.

Trust in Allah, but tie your camel **first**.

Let us sit bent, but talk straight.

When the feathers are of gold it is unwise to make broth of the hen.

The biggest nuts are those which are empty.

A town's gate can be shut, a fool's mouth never.

By all means make friends with the dog, but do not lay aside the stick.

Into a closed mouth no fly can enter.

If I listen I have the advantage; if I speak others have it.

The tongue has no bone, but it crushes.

Don't be deceived by the whiteness of the turban; soap is bought on credit.

If a **man** said to you, "A dog carried off your ear", would you go after the dog, or search **first** for your ear?

Allah may love a poor **man**, but not a dirty one.

A clever man's mistake is equal to the mistakes of a thousand fools.

Fortune is with you for an hour and against you for ten.

The best kindness is done quickly.

If you ask a mule of his lineage he will say only that one of his parents was a horse.

If the caliph at noon proclaims it is night, behold the stars.

A wise woman is one who has a great deal to say, yet remains silent.

When the crow is your guide, he will lead you to the corpses of dogs.

Three things can cause sorrow to flee – water, green trees, and a beautiful face.

As the sands of the desert **are** to the weary traveler, so is too much speech to him who loveth silence.

It is he who eats when he is full that digs his grave with his teeth.

A dog on the run can safely be kicked.

If Fate throws a knife at you there **are** two ways of catching it: by the blade, or by the handle.

Once you put your head into the mortar it is useless to dread the sound of the pestle.

Whoever pets scorpions with the hand of compassion gets stung.

Nourish a raven and it will pick out your eyes.

Bibliography

The following is a list of just a few of the references used in the writing of this book. If you want to add extra detail to your *games*, look some of these up at your **local library**, or **see** if you can **find** them in a nearby second-hand bookstore.

Janet L. **Abu-Lughod**, *Cairo: 1001 Years of the City Victorious*, Princeton University Press, 1971. A social history of Cairo that reads like the **Ph.D.** thesis it is.

G. W. Bacon. *Bacon's Guide Map of Cairo*, 1929. A large fold-out map of Cairo. Fragile and rare.

Karl Baedeker, *Egypt and the Sudan: Handbook for Travellers*, 1929 (reprinted 1985). The definitive Egypt in the 1920's. All you ever needed to **know** and much, much more.

Paul **Brunton**, *A Search in Secret Egypt*, Rider & Company, 1935. This guy has a **SAN** of **0**. He holds conversations with pharaohs and ghosts on his visit to Egypt in the late 1920's.

E. A. Wallis Budge, *The Dwellers on the Nile*, Dover Books, 1977. A social history of the ancient Egyptians. Still in print.

———, *An Egyptian Hieroglyphic Dictionary* (2 volumes), Dover Books, 1978. The complete dictionary of Ancient Egyptian. Has a great section listing all of the characters used in the Coptic, Hebrew, **Syriaic**, Arabic, Ethiopic, Amharic, and **cuneiform** alphabets. Still in print.

Barry **Carman** and John McPherson (editors), *Bimbashi McPherson: A Life in Egypt*, BBC Books, 1983. The book of the TV series about the life of Bimbashi McPherson, secret agent in Cairo in the 1920's.

C. W. **Ceram**, *Gods, Graves and Scholars*. 2nd edition, 1967.

Christine el-Mahdy, *Mummies, Myth and Magic, Thames and Hudson*, 1989. All you ever wanted to know about death and **mummification** in Egypt.

Lt. Colonel P. G. **Elgood**, *The Transit of Egypt*, Edward Arnold & Co., 1928. A political history of Egypt in the early 1900's. Has a good **timeline**.

Egypt, Insight Travel Guide, APA Publications, 1989. A **modern guidebook** with excellent historical details but very few maps.

Raymond **O. Faulkner** (translator), *The Ancient Egyptian Book of the Dead*, British Museum Publications, 1985. **ALL** the spells you ever wanted and more. Dover Books has this in print in the E. A. Wallis Budge translation.

E. M. Forster, *Alexandria: A History and Guide*, 1982. Originally published in 1922, this is an excellent **source** of information on Alexandria.

Sir Wilfred Thomason Grenfell, *Labrador Looks at the Orient*, Jarrolds Publishers, 1928. A Canadian visits Egypt and the Middle East.

H. P. **Lovecraft**, "Imprisoned with the Pharaohs", in *The Tomb and Other Tales*, Ballantine Books, 1970.

———, "The Outsider", in *The Dunwich Horror and Others*. Arkham House Publishers. 1963.

Lawrence R. Murphy, *The American University in Cairo: 1919-1987*, AUC Press, 1987. A history of the AUC.

The **P&O Pocket Book**, 1922. A guide to all of the cities visited by **P&O** cruise ships. Rare.

Plan and Guide of Cairo, Sitmar Shipping Company, 1933. A 24-page booklet and map issued to **all** passengers. Very **informative** but rare.

Thomas Russell Pasha. *Egyptian Service 1902-1946*, 1949. The autobiography of the Chief of Police in Cairo in the 1920's.

Hanna Ryadh, *The Land of the Sun God*, George Allen & Unwin, 1929. A Swedish woman visits Egypt and Cairo.

Robert Silverberg, *Empires in the Dust*, Chilton Books, 1966. A very readable general book on ancient empires of the world.

Desmond Stewart, *Great Cairo, Mother of the World*, Rupert Hart-Davis, 1978. A history of Cairo. A bit short on the 1920's.

lime Capsule 1923 (also 1927, 1929), Time Life Books. A year of excerpts from *Tune* magazine. Full of **all** sorts of details that no Keeper should be without.

Walter Tyndale, *An Artist in Egypt*, Hodder & Stoughton, 1912. The travels of **an** artist in Cairo and Egypt in 1910-1912. Exquisite watercolor illustrations. Rare.

Scott Wayne, *Egypt and the Sudan*, Lonely Planet Publications, 1987. A modern travel guide with good maps.

Other inspiration can be obtained from watching films and television, such as:

Death on the Nile (set in 1932)

Lawrence of Arabia (set during 1914-1922)

Raiders of the Lost Ark (set in 1936)

selected episodes of *Young Indiana Jones*

Index

- air travel 1
 Akhenaten (Amenhotep IV)
 27.63.64.65.69.75. 88
 Al-Azhar University
 20, 24, 28, 44-46, 84
Al-Azif .. 27.29.30.36.45.46. 83
 Alexander the Great .. 4.9.27. 69
 Alexandria 1, 3, 4-9, 13.27.36. 83
 Alexandria map 5
 Amenhotep III 34.77. 88
 American University in Cairo
 (AUC)..... 16.19.4.648
 Amun 67.69.70. 72
 ancient harbor 7
 Anglo-American Nile & Tourist
 Company 62.66.70. 77
 antiquities export 3
 Anubis 7
 Arab Museum 16. 36
 Aswan 76-77
 Aswan Dam 76
 Aswan map 77
 Aswan Museum 77
 Aten 63.65. 69
 Atlantis 7
 Acum 71
 asylums 37.41
 Azathoth 36.64. 69
 banks 6. 77
 bars 21
 Bast 49
 Bedouin . 50.59.63.76. 79.80-82
 Black Pharaoh .. 36, 64, 65, 66, 73
Book of the Dead 35.36.45.
 59. 71.73.76.77.8 3-84
 booksellers 6.25.26.2 7.28
 Brethren of Seth 76. 82
 British control 11-12
 Brotherhood of the Black Pharaoh
 36.61. 82
 Budge. E. A. Wallis 78. 99
 cabs 6.10. 13
 Cairo map 15
 Calais 1
 camel racetrack 50
 camels 20, 49, 50, 58, 62
 canopic jar 27. 35
 Carnarvon, Lord 18.35. 75
 carriages 6
 cars 1.13.62
 Carter. Howard . 18.35.70.75. 78
 cemeteries 33.50.54
 Cheops 59. 60
 Children of the Sphinx
 19.49.61.82. 84
 Churchill, Winston 18.78. 79
 cinemas 22
 Citadel. the 16.29.3 1. 54
 civil disturbance
 11.12. 13. 18.24. 48
 climate 4
 clubs. private 22.23
 coffee shops 42.44
 Constantinople 1. 3
 consulates 6.10. 66
 Coptic Museum 32.84
 Coptics 32, 35, 36, 51, 77
 cost of living 13
 cruise schedule 62
 customs 3. 10
 Dagon 7. 36
 deep ones 8.9.11.27. 83
 dervish 29. 39
 Dionysis 7
 donkeys 16.20.58.63. 66
 dragoman 3-4, 20
 Dreamlands 35.36. 54
 drugs 3.21.32.41.43.56. 57
 Egypt map vii
 Egyptian meal 21
 Egyptian Museum ... 3. 16. 19.27.
 28, 33-36, 59, 65, 66, 73, 84
 Egyptian University 48
 Elephantine Island 76. 77
 entertainment 22-23
 excavations .. 7.33.59.61.64. 66
 exchangerates 4
 Ezbekiya, the ... 16.20.21.23. 57
 farming 10
 Fayoum 8. 11.36.82. 83
 Fort Kait Bey 8
 Fuad (Prince. then King)
 11. 12.18. 78
 gambling 23.44.50. 62
 games 43.44
 Genoa 3
 ghuls 54
 Giza 58.61
 glossary 95-98
 gods 85-86
 Golden Dawn 36.82
 Graves. Robert 18. 78
 Great Pyramid 60. 61
 Groppi's 19. 21
 guns 3. 26
 harem 22. 23
 Hathor 34. 49, 70
 Heliopolis 1.7.13. 20
 Heqit 49
 Hermes 7
 Hermes Trismegistos 84
 hippopotamus 49
 holidays 40
 hookah 24. 43
Horror on the Orient Express 1, 82
 Horus 49. 70
 hospitals 41. 76
 hotels 6. 10.16-20.66.76
 hyena 49
 India 1
 Isis 70
 jackal 50. 54
 Karnak 67-69
 Khan el-Khalili 24-27. 51
 Khnum 49
 King of the Wasa 57. 78
 Kom esh Chogafa catacombs ... 7
 Lawrence. T. E. 18.79-80
 libraries 6.20.23.
 28.30.33.45.47.52. 84
 Library of Alexandria 4. 6
 Libya 1
 London 1. 3
 Luxor 66-67
 Luxor map 67
 magic 83-84
 Marseilles 1. 3
Masks of Nyarlathotep 82
 Masons 28.36. 82
 Medieval Cairo 23-29. 36
 Mediterranean map 2
 Mohammedanism 39-40
 money 4
 Mont 71
 Mosque of Ibn Tulun 37
 Mosque of Muhammed Ali 31
 Mosque of Sultan Hasan 38

- Mosque of the Prophet Daniel . . . 9
 mosques 9.31.33.3 739
 Mount Ararat 37
 mummification 84
 mummy 84
 Museum of Geology 36
 Museum of Greco-Roman Antiquities 7.8.84
 museums 8.32.33.36.77
Muski, the 24
 Mut 49
 Napoleon 17.26.61. 69
Nefertiti 63.88
Nekhebet 49
 Nephren-Ka 64.65
 New York 1.3
 Nile Delta 1, 9, 10-11. 13. 16.36
Nile River 4.6.31. 61
 Nilometer 31
 Noah's Ark 37
 Nyarlathotep 36.64.73. 84
 Odyssey 7
 Old Cairo 31-33
 opera 22
 Orient Express 1.10
 Orient Line 1. 3
Osiris 34.35.69. 77
 Pacific & Orient Line 1. 3
 Palestine 1.69
 papyrus 27.36.45.59
passport duty 3
 permits 3
 petesouchi 8.9. 11.83. 84
 Petesouchos 8.83
 Pharos 4, 8
 pickpockets 3.24. 56
 politics 11-12
 Pompey's Pillar 6
 Port Said 1.3.9.10. 13
 Port Said map 9
 prison 29
 prostitution 56-57, 62, 64
 proverbs 98
 Pyramid of Chephren 58.60-61
 Pyramid of Mycerinus 61
 rabies 50. 54
 Rameses II 7.34.69.7 07 1
Rameses III 67, 69, 71-72.88
Ramesseum 707 1
Ras el-Tin palace 6 8
 restaurants 6.10.16.21. 22
 river travel 16.6 162
 route map 2
 sand dwellers 66
 sanitary **tax** 3
Sebek 7
 scarab 27.35. 83
 scenario hooks 7.8.9. 10. 12. 17
 19.27.30.31.32.33.35.36.
 37.41.43.47.49.52.54.56.
 57.61.62.64.65.69.76.77.
 82.85
 scientific societies 23
 sea travel 1. 3
 secret groups 8283
 Sekhmet 49
Serapeum 6 7
 Seth 49.54. 70
 shabti 27.84
 Shephard's Hotel
 3, 16-18, 19.20.57
 shops 6, 10, 24-27.66
 slums 57
 Sons of the **Mamluks** 22.46. 84
 spells 36. 84
 Sphinx 20.61. 82
 Stack, Sir Lee 11.79
 stele 27
Suchos 49
Suez Canal 1.9.10. 13
 Tel el-Amarna 36, 6366
 temperature 4
 theater 22
Thebes 36, 63, 70-72, 88
 theft 56
 Thomas Cook & Son
 3, 34, 61-62, 66, 77
Thoth 49. 71
 time zones 4
timeline 87-94
 Tombs of the Caliphs 16.5 1-52
 Tombs of the **Mamluks** 29.52. 54
 trains 1.6.10. 13.62.76
 trams 6.10. 16
 transportation 6.10. 13
 travel information 3
 traveling to Cairo 1
Tutankhamun 18.27. 33
 34.35.56.63.72.73.75. 88
 universities 44-48
 Valley of the Kings
 19.27.35.59.70.7 276
 Valley of the Kings map 72
Wafd, the 12.44
 walking 16
Wasa, the 57
 welcome letter 14
Wep-Wawet 49
 White Star Line 1. 3
 women. status of .6. 16.21.22.23.
 24, 37, 40, 42, 44, 46, 56, 81
 words of power 83
 Zaghlul Pasha 11.12.79
 Zoological Gardens
 16.19.48.49.61. 82
- NPC's**
Ahmed, Bedouin guide 59
 Margaret **Ainsworth**, American
 University at Cairo student . 48
 Aasim **Al-Rahman**, antiquities mer-
 chant 27
Ibrahim Amin, Al-Azhar Univer-
 sity student 46
Tahri Bahrin, bookseller 27
 Mustapha **Hamil**, silk merchant. 28
Khalil Kareem, Al-Azhar Univer-
 sity lecturer 46
 Hasan **Karmann**, expedition sup-
 plier 28
Bimbashi McPherson, **coffee** shop
 owner 43.79. 99
Saleem Naziz, dragoman 4
 Mohareb **Todrus**, restaurant owner
 22.83
 Patricia **Vickersley**, American Uni-
 versity at Cairo Professor . . 48
 Garth **Weder**, Egyptian Museum
 curator 33.35.36. 73
Muhammed Yehya, camel driver 50

#2351

CAIRO

Scale

1/2 mile

THE

CAIRO

GUIDEBOOK

The Lure of the Nile



The opening of the tomb of Tutankhamun in 1922 and the breathtaking beauty of the treasures within sparks a wave of Egyptomania that washes across the world. Dowagers and flappers alike wear Egyptian-style jewelry. Men wear turbans to work on Wall Street, and smoke hashish from nargheeh water pipes. The animalistic motifs of ancient Egyptian art blend with the clean lines of Art Nouveau to create new styles of interior decorating.

Excavations in the Valley of the Kings make or break the careers of archaeologists. Some reap fortunes from copying tomb items and selling them as genuine artifacts. Others steal genuine artifacts and re-sell them to unscrupulous collectors.

Frequent riots and political assassinations challenge British rule, but Egypt is to be a protectorate of the British Empire for decades more. Westerners openly wear guns in the streets of Cairo, but sternly forbid firearms to the locals.

Visitors are thrown into a powder-keg of political intrigue and sordid motive, of anarchy and rich adventure as romantic and improbable as a tale from the Arabian Nights.



Marion Anderson

THE CAIRO GUIDEBOOK is set in the 1920s. With it, Keepers can easily base many adventures in and around this teeming city. Dozens of scenario hooks are highlighted in the text. Period maps of Cairo, Alexandria, and Port Said are included, and dozens of plans of ancient and modern-day structures are shown. Getting to Cairo is detailed. The sights of Cairo, and the important excursions possible from Cairo are discussed, as are the important people of the city and the culture of the nation. Though intended for roleplayers, all the information in this book is genuine and accurate for the period, and some is found nowhere else. Mythos influence is considered. There are also resources concerning the gods of ancient Egypt and an extensive timeline of events from Pre-Dynastic Egypt through the end of the 1920s. Indexed. Dozens of illustrations and more dozens of maps and plans. 112 pages.

CATALOG
Books and games?

Chaosium Inc.

10101 NE ALBANY STREET, OAKLAND, CA 94608-3129

