

Palladium Books® Presents:

Rifts® World Book 33:

Rifts® Northern Gun™ 1

By Matthew Clements
& Kevin Siembieda



Warning!

Violence, War, Magic & the Supernatural

The fictional worlds of **Rifts**® are violent, deadly and filled with aliens, war and supernatural monsters. Other-dimensional beings often referred to as “demons,” torment, stalk and prey on humans. Alien life forms, monsters, vampires, ghosts, ancient gods and demigods, as well as magic, insanity, psychic powers and combat are all elements in this book. *All of it is fiction.*

Some parents may find the violence, magic and supernatural elements of the game inappropriate for young readers/players. We suggest parental discretion.

Please note that none of us at Palladium Books® condone or encourage the occult, the practice of magic, the use of drugs, or violence.

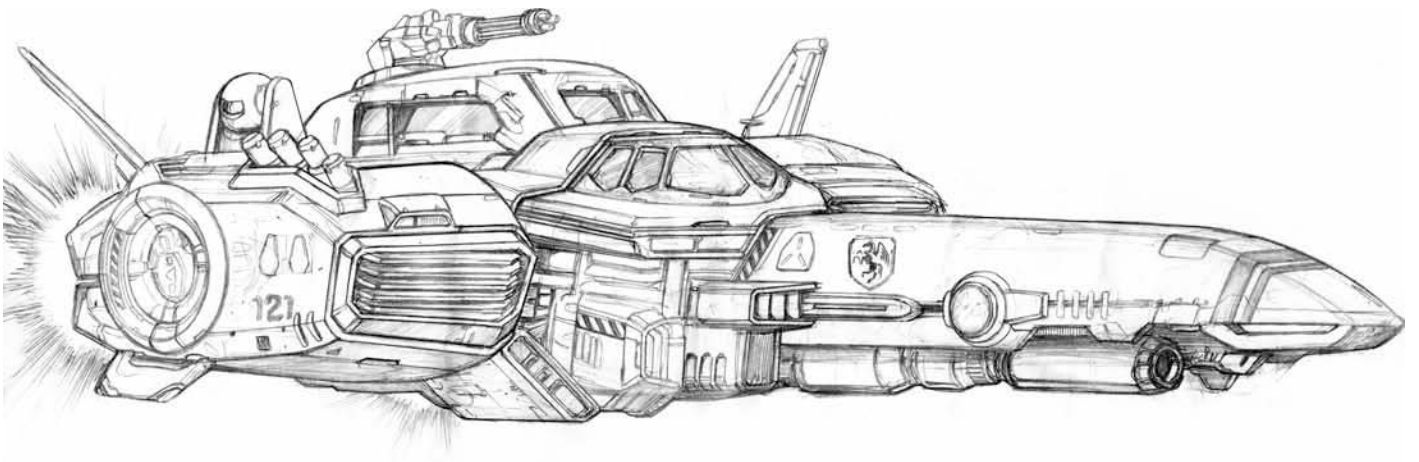

Rifts® World Book 33:

Northern Gun™ One

Rifts® Northern Gun™ One is an epic World Book that contains a wealth of information, characters, locations, O.C.C.s, robots and weapons from the largest arms dealer and independent manufacturer on the continent: *Northern Gun*™.

- In-depth look at Northern Gun, its robots, stores, politics and operations.
- 70+ NG weapons; old and new.
- 27 NG giant combat and exploration robots. Described in detail.
- Many new robot weapon systems and features, including alternative power supplies, anti-monster gear and experimental weapons.
- Northern Gun freighter ships and hovertrains.
- Notable cities and people of the Ishpeming Republic/Northern Gun.
- NG O.C.C.s, police, specialists and NG Mercenary army.
- The NG Bounty Board, the largest collection of bounties and mercenary contracts anywhere on Rifts Earth.
- Key locations, people and dangers around Northern Gun.
- Northern Gun's relationship with the CS and other nations.
- 224 pages written by Matthew Clements and Kevin Siembieda.

An epic sourcebook for the *Rifts*® series.

Compatible with the entire Palladium Books® Megaverse®

Dedication from Matthew

This book is dedicated to the people of Michigan; in the past, present, future and all the various realities of the Megaverse. Geography shaped us like a mitten, politics gave us a beautiful second peninsula, and people have built a state that both Palladium Books and I are proud to call home. It was a privilege to breathe life into such a pivotal player on the world of *Rifts Earth*, a task that I enjoyed immensely both as a writer and as a fan. I only hope you all have as much fun exploring Northern Gun as I did.

– Matthew Clements, August 2013

Dedication from Kevin

To the millions of Rifts® fans. Your love and support is what kept us going during the worst of times, and keeps us striving to do our best, always.

– Kevin Siembieda, August 2013

The cover, by *Charles Walton*, depicts the immediate aftermath of a battle between a hostile dragon and a Northern Gun mercenary company armed with NG combat robots and power armor. The location, a remote part of Upper Michigan.

First Printing – October 2013

No part of this publication may be scanned, OCR'd, reproduced or distributed in any way for electronic publication on the web/internet or any other medium.

Copyright 2013 Palladium Books Inc. & Kevin Siembieda

All rights reserved, worldwide, under the Universal Copyright Convention. No part of this book may be reproduced in part or whole, in any form or by any means, without permission from the publisher, except for brief quotes for use in reviews. All incidents, situations, institutions, governments and people are fictional and any similarity, without satiric intent, of characters or persons living or dead, is strictly coincidental.

Rifts®, The Rifter®, Megaverse®, The Mechanoids®, The Mechanoid Invasion®, Phase World®, Splicers®, Coalition Wars®, After the Bomb®, RECON®, Nightbane®, The Palladium Fantasy Role-Playing Game® and Palladium Books® are registered trademarks owned and licensed by Palladium Books Inc. and Kevin Siembieda.

Anti-Monster, Archie-Bot, Archie Three, Arzno, Baby Boom Gun, Boom Gun, Bandito Arms, BigBore, Bio-Armor, Biomancy, Biomancer, Bio-Constructs, Biomancer Gene-Mage, Bio-Wizard, Blind Warrior Women, 'Bot, 'Borg, 'Burb, Brodkil, Chaos Earth, Chicago Network, Chi-Town, City Rat, Coalition States, CS, Coalition State of El Dorado, Colorado Baronies, Combat Cyborg, Coming of the Rifts, Crazy, Cyber-Doc, Cyber-Knight, Dead Boy, Deluded Vampire, Doc Reid, Dog Boy, Dog Pack, Dinosaur Swamp, Dyna-Bot, E-Clip, Elemental Fusionist, Emperor Prosek, Erin Tarn, Federation of Magic, Free Quebec, Gargoyle Empire, Glitter Boy, Great Cataclysm, Gunbot, Gunwolf, Headhunter, Horune Pirates, Hunter Mobile Gun, Iron Heart, Juicer, Lazlo, Lemurian, Le Marche Noir, Ley Line Walker, Lord Splynnncryth, Madhaven, Magic Zone, Manistique Imperium, Megabot, MercTown, Mind Bleeder, Mind Melter, Mobile Medical Robot, Multibot, Naruni, Naruni Enterprises, Naut'YII, NGR, New German Republic, New Navy, Northern Gun, Okemos Explorer, Pecos Empire, Psi-Stalker, Psyscape, Psykes, Reid's Rangers, Rifts Earth, Rift Runner, Secondary Vampire, SAMAS, Shadow Boy, Shemarrian, Shifter, Simvan, Skelebot, Splynn Dimensional Market, Splugorth, Minions of Splugorth, Splugorth Slavers, Stone Magic, Stone Masters, Super-Max, Tattooed Man, Techno-Wizard, Thundercaster, Tolkeen, Triax, True Atlantean, Ulti-Max, Undead Slayer, Vampire Kingdoms, Rifts® Game Master Guide, Rifts® Book of Magic, Rifts® Atlantis, Wild Vampires, Wilk's, Xiticix, Mega-Damage, M.D.C., S.D.C., I.S.P., P.P.E., and other names, titles, initials, characters, character likenesses, and slogans are trademarks owned and licensed by Kevin Siembieda and Palladium Books Inc.

Palladium Online: www.palladiumbooks.com – also visit us at [facebook.com/PalladiumBooks](https://www.facebook.com/PalladiumBooks)



Rifts® Northern Gun™ One – A Rifts® World Book is published by Palladium Books Inc., 39074 Webb Court, Westland, MI 48185-7606. Printed in the USA by McNaughton & Gunn.

Palladium Books® Presents:

Rifts® World Book 33:

Northern Gun™ One

Conceived by: **Matthew Clements**

Written by: **Matthew Clements & Kevin Siembieda**

Additional Writing & Ideas:

Carl Gleba

Carmen Bellaire

Charles Walton

Editors: **Alex Marciniszyn**

Wayne Smith

Kevin Siembieda

Proofreader: **Julius Rosenstein**

Cover Illustration: **Charles Walton**

Interior Artists:

Amy L. Ashbaugh

Wayne Breaux Jr.

Mark Dudley

Kevin Long

Allen Manning

Brian Manning

Michael Mumah

Tanya J. Ramsey

Benjamin Rodriguez

Charles “Chuck” Walton II

Art Direction: **Kevin Siembieda**

Typography and Layout: **Wayne Smith**

Based on the RPG rules, writings, characters, settings, concepts and Megaverse® created by **Kevin Siembieda**.

Special Thanks to *Matthew Clements* for his ideas and wonderful words, to *Carl Gleba* and *Carmen Bellaire* who are always an inspiration, to *Chuck Walton* whose imagination and artistry sends my own imagination into overdrive, to all of Palladium’s incredible artists, *Chuck, Mike, Mark, Brian, Allen, Tanya, Ben, Mike, and Amy*, and to the Palladium crew, *Alex, Wayne, Kathy, Julius* and *Jeff*, all of whom have made this book, and so many others, a reality.

– *Kevin Siembieda, 2013*

Megaverse® Insiders

Inside Help

Juan Baez, Nathaniel Baker, Ben Bingham, Steven Brewington, Amanda Butka, Rosalena Butka, Dan DeLuca, Andrew Gillespie, Steven A Hauser, Paul Herbert, Nathan Jacobus, Steven Lambert, Frank Loose, Jason Martin, Colin McBride, Jacob Postlewaite, Mel Primus, Sean Reed, Martin Schultz, Frank Uhrmann

In Memoriam

Susan A Beasley, Anne Brett, Lee Carroll, Michael Collins, Steven Glenwood Knorr, Jason Lee, Bill “Shepherd” Sheets, Jeanette Spahr

A Real Character Tribute

Big Bubba, Mega Juicer, Daventhalas de Mont Hault, Jack Chriax, Jirad Crocker, Kasha “Night Shard” Morimoto, Leon “Captain Guam” Martinez, Lord Silverthorn, Martean Mursi, Melena Alys’ka of Jages Clan, Papa Zen, Sakura Hayase, The Great Mysterious Tattooed One King Zarchron

Cyber-Insiders

Sabrina Akins, Chris Altobelli, Thomas Andary, Andrew Antolick, Damon Armstrong, Nathaniel Baker, Michael Barakofsky, Benjamin Barbre, Nathan Bingham, Benjamin Bonds, James Briggs, Jeff Bunde, Brent Burnett, Barry Buse, Anthony Casab, Bruno Cerebelaud, James Chance, Oswin Chang, Frederic Christie, Phillip A Compher, Mike Creelman, Donald Dalton, Matthew Daye, Greg Diaczek, Jason Domke, Bryan Downing, Kevin Dyal, Stewart Easton, Robert Edmunds, Michael Estrada, Jeff Farrar, Curtis Fielder, Allan Fierro, Brandon Fong, Glenn Francis II, John Frederick, Daniel Garza, Scott Gibbons, Scott Goric, James Grey, Ron Guest, Kimihiro Hamaura, Craig Hammer, Jonathan Harris, Jacob Healey, Alexander Heck, Paul Herbert, James Holt, David A Hughes, Charles Huighe, Michael Ivie, Sean Jenkins, Jeff Jensen, Michael Johnson, Neil Johnson, Alan Jones, Demetrius Karanikolas, Nolen Keith, James Kenagy, Chris Kluge, James Koski, Ralph Lajara, Magnar Laksa, Seth Lamble, David N Lang, Scott Leopold, Brian Lindholm, Joseph MacIsaac, Michael Macolley, Jeffery Martin, Luis Martinez, Benjamin Mason, Sara McLauchlan, Peter Melendez, Frederick Meyer, Peter Michalenka, Chris “Wolff” Miller, Frank Mitchell, David A Moffatt, Thaddeus Moore, Christopher Murray, Aaron Nelson, Matthew Newton, Becky Northaven, Joseph Olewnicki, Leigh O’Neil, Michael Ong, Brandon Pack, Pepsi Jedi, Jeff Peterson, Victor Peterson, James Plowman, Melissa Powell, Jeff Reade, Michael Reagin, Stephen Schneider, Thomas Schrupp, Trent Slater, Michael Smith, Michael Strom, Chad Trantham, H. E. Werkheiser, Ryon Wiebens, Jason Williamson, Matthew Wontroba, Jeff Woodman

Palladium Insiders

Dylon Amerasinghe, Jeremy Berkowitz, Brendan Blackmer, Rick Bray, Connor A. Brown, Vernon Brown, Brent Burnett, Stephen Butka, Eric Campion, David Chittim, Gregory John Clark, Cory Crandall, Eric Crump, Stephen Daniel, Jeremy Davis, Greg Diaczek, Timothy Dixon, Brett Easterbrook, Carl J. Gleba, John Guibert, Denny “Kegleneq” Ham, Hendrik Harterich, Josh M Kaplan, Thomas Karras, Chris Kluge, Nick Krupar, Chad Lasecki, Patrick Le Houllier, Jeff A Lee, Russell Lenhares, James Lukow, Maffy, Jeff Maltby, David Marble, Wayne Maynard, James McDonald, William McGoldrick, Casey Michels, Thomas Molen, Trevor

Morehead, Kevin Myers, Warren Nelson, David Nemoseck, Evan Odensky, Joe Oertly, Michael J Osborne, Charles Pickering, Ryan Rawlings, Bradley Reeser, Michael Kyle Rose, Michael Sausaman, Steven Schlosser, William Shaffer, Ross Simmerman, Ed Surret, Nate Swalve, Daniel “OGRE” Thomas, Gregory John Ullman, D. Vroman, Nicky Warren, Steven Whittredge, Chris Williams, Dr. Winston, Joseph A Yerger

Steel Insiders

Kristopher Akers, Brandon K. Aten, Scott Banzhaf, Anthony Barrios, Mathew Bollman, Stan Chesser, Michael Copeland, Jeff Costello, Jason DeLong, Cody Dobbs, Robert Dugan, Brett Easterbrook, Michael Gale, Dale Gifford, James L. Giltz, Brian Hatherly, Richard “Fathom” Hill, Dennis Hughes, Iscerus, Dave Keiger, David Klett, Jason Lamb, Aaron Leonard, Kris Main, Stephen McDonald, Jason Mendoza, Blake Moorcroft, Scott Norman 783, Kris Perlock-Campeau, Michael Pointer, Allan “ZeroArmour” Randall, Mathew Robertson, John Santa Barbara, Edward Sauerland, Shaun Savage, Jeff Schuler, Dave Waller, Isaac Xavier-Santos, Zyxiger

Steel-Plus Insiders

Doug Buhlman, Eric Canapini, Rob Daily, Erich Eisenmenger, Jeffery Gilbert, Kenneth Gunther, Howard Holland, Torrey Jones, Shawn Kennedy, John King, Bonnie Krueger, Chadd J Leath, Arnaldo Lefebre, Timothy Letts, Branden Loizides, Mangels, Jason McQuain, Tyvernos Oriflamme, John Polack, Kerry “DeadFall” Reed, James Eric Ritchie, David Rogers, Wade Rohl, Thaddeus Ryker, Dave Simmens, Will Sproul, Erik Stewart, Chris Thomas, Charles Viaud, Shepard Williams, Stanley Woo, Steven Yeung

Top Insiders

Peter Adams, Eric Auger, Chris Axtell, Randy P. Belanger, BGJP Gaming, Rob Byrne, Steven Carroll, Brent Casavant, Jason Chapman, Jason Cogshall, Glenn Cole, Jonathon E. Conroy, Jim Cross, Dayton DeFoe, Robb Dunn, Jason Dvorchak, Bryan Ellis, Marc Ferrari, Father Morpheus, Fillinger, Trevor Fitch, Travis S. Guerrero (Prysus), Jeremy D. Helton, John Kallil, Stephen B. Keith, Dennis Kelley, Andrew Kelsoe, Scott Kendrick, Derrick Landwehr, Jorel J. Levenson, Christina Liu, Jonathon Lovejoy, Dylan Lundrigan, Ryan Mahoney, Charles J. McComb, III, Ryan McDaniel, Daniel Ogle, Ramzie Othman, Donovan Pankratz, Richard J. Perez, Orion Pobursky, Peter Porcaro Jr., Benoit Provencher, Redapple, Ammon Redman, Albert Rosado, Doug Roy, Michael Satran, Frederick R. Seibel 5th, Ian Small, Peter Smith, David Snell, Cory Sommer, Larry Todd Stanley, Chris Steinbrenner, Robert Steiner, Lawson Stevenson, Mike Sykes, Brian Terrill, David Thompson, Ryan Thomsen, Jason M. Volinsky, Christopher Wilmer, Matthew Wood

Ultimate Insiders

Benjamin Barton, Joshua Hill, Shayn Lavender, Douglas Rood, James Walker

Benefactors

Derek Boudreaux, Lucas Buck, Terrence Carter, Kerry Cook, David Dunham, Ryan Fuerst, Shawn Johnson, John Klinkel, Todd Spencley, Brad Whitcomb

Ultimate Benefactor

Federico Franceschi

Our sincere apologies to anyone whose name was misspelt.

Rifts® Northern Gun Contents

Northern Gun	8
The History of Northern Gun	9
The Alliance with the CS	9
Northern Gun, 109 P.A.	10
The Republic of Ishpeming	10
Manistique Imperium	10
NG's Current Priorities	11
Overall Tech Levels in North America	11
Additional Tech Manufacturers	12
Northern Gun Products	12
NG Brand	13
Non-Contract Employees	13
Employees of Northern Gun	13
Pride and Corporate Culture	14
NG Factories & Manufacturing	14
Northern Gun Policies	15
Northern Gun's Policy on Magic	15
Techno-Wizardry	15
Northern Gun Policy on D-Bees	16
Spies, Theft & Corporate Espionage	16
Active Intervention	16
Naruni Enterprises	17
Coalition States	17
Policy on Reverse-Engineering	18
The Reverse-Engineering Labs	18
NG Research and Development Branch	19
The Research & Development Complex	19
Loss Prevention Office	20
Andrea Callister, Chief LPO	20
NG Trade Council	21
Trade Council Positions	21
The NGMI Credit System	23
Northern Gun Retail Outlets	23
Showrooms and Warehouse Centers	24
NG Returns Policy	24
Northern Gun Foreign Relations	24
Coalition States: Allies or Overlords?	25
The Black Market	25
Naruni Enterprises	26
The Republic of Ishpeming	29
Cities of the Republic	29
Welcome to Ishpeming, Home of NG	30
Secure Storage Bunkers	31
The Parking Area	31
Hovertrain Terminal	31
The Safe Zone	32
Security Zone	32
Defensive Bunkers	32
The City of Ishpeming	32
City Highlights	32
Corporate District	32
NG Headquarters, Ishpeming	33
Notable Corporate Officers	34

Other Areas of Northern Gun	34
A note about building size & security	34
Downtown Northern Gun	35
The Mall of Michigan	35
Ed's Used Vehicle Emporium	36
The Operators' Room	37
The Hovertrain Terminal	38
Vanderman Castle	39
NGMI Central Bank	40
Otherworldly Animal Reserve	41
The Ishpeming Region	42
Map of Upper Michigan	42
Fort Sawyer	42
Marquette	43
Naval Development Center	43
The IM Highway	43
Trenary	45
Lake Michigan Coast	45
Escanaba – "MercBay"	45
The Escanaba Docks	46
Purchasers and Resellers	46
The Discount Docks	47
Downtown Escanaba	47
The Escanaba Robodome	47
Escanaba Airfield	48
The Hub	48
NG Bounty Registry: Escanaba Office	49
Jailhouse	50
Escanaba's NG Corporate District	50
The Escanaba Road	50
Escanaba Coastal Defenses	50
Gladstone	51
Stone Island	51
Menominee, "Pirate's Point"	51
Map of Michigan & Surrounding Region	52
Menominee Air Depot	52
Wisconsin Border	53
The Iron Chain	53
Iron Mountain	54
Ironwood	54
Iron Bay	54
Porcupine Mountains	55
The Michigan Lower Peninsula	56
Green Bay	56
Plum Island Region	57
Washington Island	57
The Rest of Wisconsin	57
Lake Superior & Northern Ishpeming	58
Houghton	58
Keweenaw Peninsula	59
Apostle Islands	59
Ontonagon	60
Task Force X	60
IMCN: Ishpeming Military Contract Network	62
Monthly Pay Rates	63

Common Assignments	63	Weapon Systems	111
Contract Bidding	64	NG-V50 Bigfoot	112
IMCN School of Soldierly	64	Weapon Systems	114
Annual Mercenary Exercises	64	Special Rapid-Fire Strafing Burst	114
Notable Military Contractors of IMCN	66	Communications and Sensor Suite	115
Big Money Militia	66	AX-44 Bison Battler	116
The Lakeguard	67	Light Flamethrower	117
Duckworth's Marines	69	Blocker Combat Robot	118
The Patrol	71	Blocker Shield	120
The NG Bounty Registry	73	NG-V32 Bruiser	120
Standard Bounty Registry Rates	73	High-Impact Piston Arms	122
Other Common Bounties	74	NG-V34 Buffalo	123
Notable Bounties Wanted Dead Only	75	Twin Particle Beam Turrets	124
Northern Gun O.C.C.s	76	EX-20 Bulldog Explorer	124
Bush Pilot O.C.C.	76	Gunbot Robot-Killer	126
NG Loss Prevention Officer (LPO) O.C.C.	78	Grenade Cannon	128
Monster Responder O.C.C.	80	Gunwolf	129
NG Police Officer O.C.C.	82	Dual NG-232 Rail Guns	132
Police Interceptor Rocket Bike	85	Special Ammo Rounds	132
Light Police Power Armor	86	Wolf's Head Weapon Platform	133
NG Robot Control O.C.C.	86	Wolf's Howl Anti-Monster System	133
NG Sales Rep O.C.C.	88	NG-V67 Grizzly	134
Freighter Traffic on the Great Lakes	90	Shoulder Flare Chaff Launchers	137
Random Freighter Generation Tables	90	HEX Grenades	138
Step One: Ship Type	90	3-D Camera & Holographic Projector	140
Step Two: Shipping Vessel Armaments	90	Wooden Spike Thrower	140
Step Three: Ship's Crew	91	Hunter Mobile Gun	141
Step Four: Ship's Cargo	91	Howitzer Rail Gun	143
Step Five: Presence of Cargo	92	Hunter Mobile Gun, Block IV Upgrade	143
Tugboats & Lake Escorts	93	Rail Gun Cannon	146
Northern Gun Hovertrains	93	'Big Papa' Mobile Medical Robot	147
Hovertrain Locomotive	95	Utility Arms & Jaws of Life	149
Hovertrain Boxcars/Flatbed/Passenger Cars	96	M.D. Chainsaw	150
Hovertrain Weapon Cars	97	Sensor Arm	150
Random Hovertrain Generation Tables	98	Finger Multi-Medical Scanner	151
Northern Gun Robots	100	Field Hospital Clinic	151
Alphabetical List of NG Combat Robots	100	Nano-Robot Medical Systems	151
Standard Features of NG Robots	100	'Junior' Mini-Mobile Medical Robot	152
Reinforced Pilot Compartment	101	Clamp Finger	153
Alternative Fuel Systems	101	'Original' Multibot	154
Solid Oxide Fuel Cells	101	Flying Hovercraft	155
Standard Solid Oxide Fuel Cells	102	Scissor Launchers	155
Heavy-Duty Solid Oxide Fuel Cells	102	NG-M57-2N1 Megabot	157
Dangers and Limitations	102	M.D.C. of Combat Racer	157
Converting Vehicles to Solid Oxide Fuel Cells	102	Statistical Data Megabot	159
NG's Electric Batteries	102	Statistical Data Combat Racer	159
Beachmaster Amphibious Assault Robot	103	Heavy Ion Cannon	159
Heavy Flamethrower	105	Tactical Cameras	160
M.D. Chainsaw	105	NG-EXC-17 Ogre	160
Electric Field Antenna	105	Pop-Up Mini-Missile Launcher	162
EX-5 Behemoth Explorer	106	EX-11 Okemos Explorer Robot	163
EX-9 Behemoth Super-Explorer	107	Heavy Machine-Gun	166
Super-X Features of Note	108	NG-EX-V50 Scorpion Battler	167
Other Notable Features	110	Tail Multi-Weapon Platform	169

Chainsaw Pincer	170	NG-P7 Particle Beam Rifle	202
NG-SE48 Sunfire	171	NG-P9 Heavy Particle Beam Rifle (new)	202
Solar-Powered Laser Cannon	173	NG-P85 Personal Particle Beam Cannon (new)	203
Variable Bore Rail Gun	173	NG Plasma Weapons	203
Holographic Decoys	173	NG-E4 Plasma Ejector	203
NG-V10 Super Labor Robot	174	NG-E12 Heavy Plasma Ejector	204
NG-8000 Super Max	175	NG-E15 Pulse Plasma Ejector	204
Robot Handheld Rifle: Rail Gun	178	Rail Guns & Non-Energy Weapons	204
Robot Handheld Rifle: Particle Beam	178	NG-T9 Dart Tranquilizer Pistol (new)	204
Beehive Grenade Launchers	179	NG-T12 Dart Tranquilizer Rifle (new)	205
Command and Control Head/Pod	179	NG-MC1 Mega-Crossbow	205
NG-V58 Thundercaster	180	NG-B10 Bangstick (new)	206
Variable Projectile Cannon	182	NG-B20 Bangstick Hammer (new)	206
NG-V41 Viking	184	NG-B30 Bangstick Staff (new)	206
Automatic Grenade Launcher	186	NG-B40 Bangstick Anti-Vampire Weapon (new)	207
NG-V39 Volcano	187	NG-B50 Thunderer BigBore Combat Hammer (new)	208
Heatwave Emitter	189	NG-11S Sawed-Off	208
NG Weapons	190	NG-R50 Mini-Rail Gun	209
Northern Gun Production Blocks	190	NG-101 Rail Gun	209
NG-33 Laser Pistol	191	NG-202 Rail Gun	209
NG-35 Heavy Laser Pistol (new)	191	NG-303 Infantry Mini-Rail Gun	210
NG-Super Laser & Grenade Pistol	191	NG-404 Heavy Rail Gun	210
NG-45LP Long Pistol	191	NG-505 Heavy Rail Cannon (new)	211
NG-LP25 Laser Pulse Submachine-Gun	192	NG-1001 Robot Rail Gun	211
NG-L5 Laser Rifle	192	NG-R1002 Robot Rail Gun/Assault Rifle	212
NG-LG6 Laser Rifle & Grenade Launcher	193	NG-101-ARG Automated Rail Gun	212
NG-SR3 Marksman Laser Sniper Rifle	193	Other Weapons & Ammo	213
NG-SL20 Sniper Laser Rifle	194	NG Specialty Rail Gun Ammunition	213
NG-SSL20 Super-Sniper Laser Rifle	194	NG Explosives	213
Seasnake Series Lasers	195	NG Hand Grenades	213
NG-SE3 Laser Emergency Side Arm (new)	195	Plastique & Other Explosives	213
NG-SE5 Laser Pistol (new)	195	Grenade Knife (new)	214
NG-SE9 Sharpshooter Laser Pistol (new)	195	NG-GL10 Grenade Launcher	214
NG-SE14 Laser Burst Pistol (new)	196	NG Mini-Missiles	215
NG-SE17 Laser Carbine (new)	196	NG-ML6 Mini-Missile Launcher	215
NG-SE20 Laser Rifle (new)	196	NG-ML7 Mini-Missiles Launcher	215
NG Solar Powered Lasers	197	NG-Mines	216
NG-UV1 Solar Powered Mini-Laser (new)	197	NG Anti-Personnel Mines	216
NG-UV4 Solar Powered Laser Pistol (new)	197	NG Anti-Vehicle Mines	216
NG-UV7 Solar Powered Laser Rifle (new)	198	NG NM-3 Firefly Plasma Mine	216
Heavy Energy Weapons	198	NG NM-4 Claymore	216
NG-H5 Holdout Ion Pistol	198	NG NM-9 Plasmore Mine	216
NG-56 Light Ion Pistol	198	NG NMBS-11 Bio-Sensor Mine	217
NG-57 Heavy Duty Ion Blaster	199	NG NM-12C Smart Scatter Mine	217
NG-59 Ion Pistol & Grenade Launcher (new)	199	NG NMX-18 Stinger Anti-Flyer Mine	218
NG-IP7 Ion Pulse Rifle	199	Product Note	218
NG-IR5 Ion Rifle (new)	199	NG Vibro-Blades	218
NG Ion Scatter Series	200	Dare to Imagine	219
NG-I26 Ion Scatter Rifle (new)	200	Experience Tables	220
NG-I8 Light Ion Scattergun (new)	200	Quick Find Index	221
NG-I13 Medium Ion Scattergun (new)	200	Also from Palladium Books®	224
NG Particle Beam Weapons	201		
NG-PB713 Particle Beam Pistol (new)	201		
NG-P5 Light Particle Beam Rifle (new)	201		

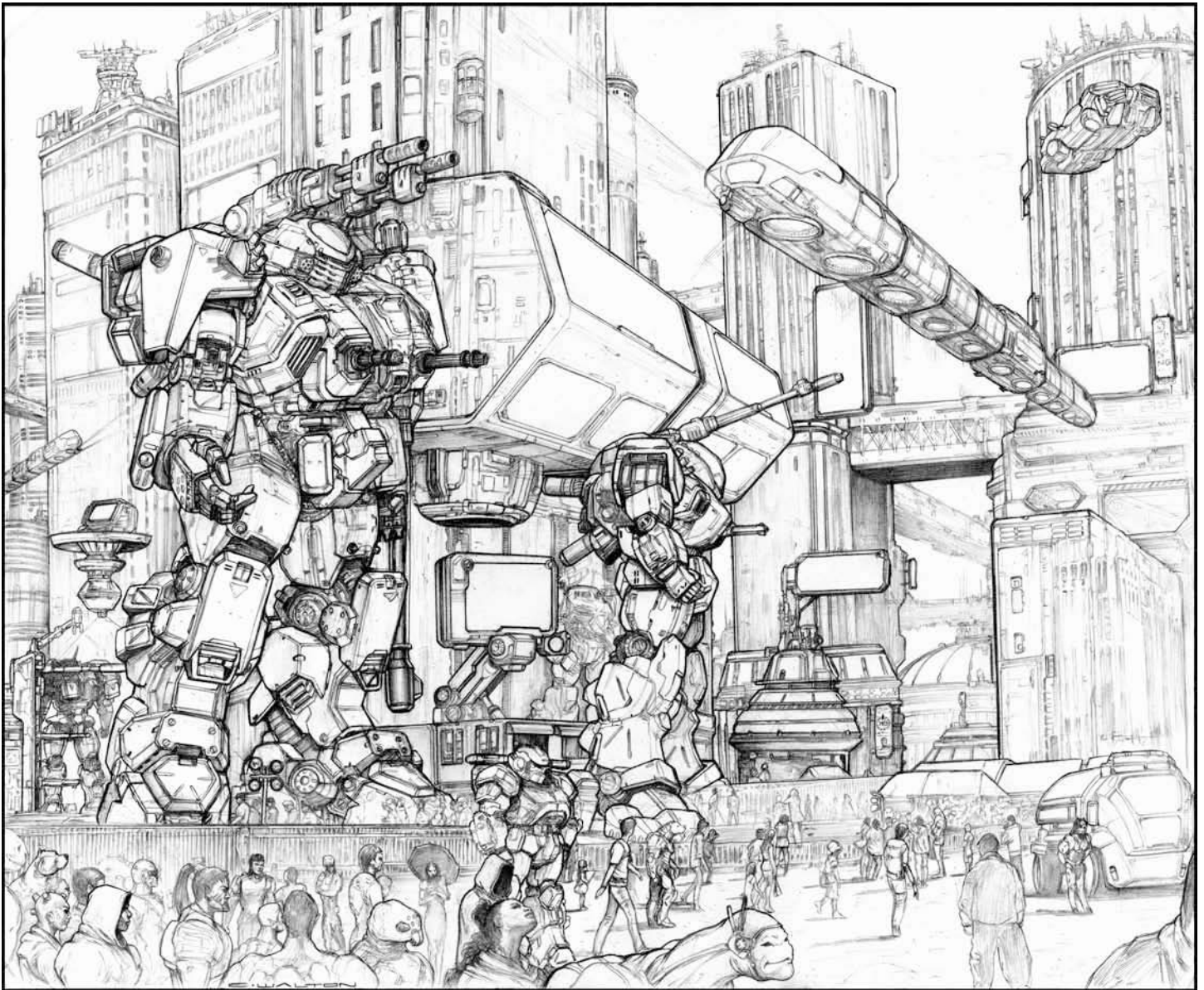

Northern Gun and the Republic of Ishpeming

On all of Rifts Earth, there is one company that provides equipment for more mercenaries, adventurers and independent soldiers than any other: **Northern Gun**. While *Triax* may enjoy a virtual monopoly in Europe, and there are state armies and alien corporations with more advanced technology, it is the infamous, and many would say, *heroic* Northern Gun that dominates the free market in *North America*. They produce everything from boots and electric lanterns to combat robots and long-range missiles. Customers with distinguished tastes have learned to associate the Northern Gun “brand name” with sturdy, reliable equipment that can take a beating. In recent years, NG has dramatically expand-

ed their product line with an eye towards equipping mercenaries and adventurers, as well as wilderness settlers and filling lucrative military contracts. The year 109 P.A. has seen the unveiling of an impressive array of new exploration and combat robots, power armor and vehicles. Things that NG had been developing for some time.

Northern Gun is many things: An arms merchant, an economic powerhouse, an independent state, a Black Market collaborator, and a stronghold of humanity. Without the millions of small arms and military weapons and vehicles they have provided over the decades, humanity’s grip on North America would be

significantly reduced. Even the Coalition has purchased Northern Gun products in mass quantities and supports their stores and outlets to a limited degree. The corporate entity that is NG has grown so powerful that it has eclipsed the *state of Ishpeming* that gave it birth. Many of the average folk encountered in North America will be confused when asked about “Ishpeming,” but all know the **Northern Gun** name in an instant. Next to the Coalition Death’s Head symbol, the Northern Gun “NG” logo is the most recognizable image on the continent, even to the completely illiterate.

The History of Northern Gun

During the Dark Age, mankind teetered on the brink of extinction. Strange new forces had come to dominate the world and there was little that could be done to stop them. What defenses mankind did have were primarily based on technology, the weapons and war machines left over from the Golden Age’s mastery of science. Those who hoarded these weapons were the only hope for desperate refugees and survivors and quickly became centers of power. *The Coalition States* are built on the technological bones of the old world, and the *New German Republic* could never have stood up to the Gargoyle Empire without *Triax Industries* and its nearly intact pre-Rifts lineage. These two centers of preserved technology grew into great nations, the pinnacle of human civilization on Rifts Earth.

There were other cities and kingdoms that grew out from the cracks and crevices of the apocalyptic landscape. Far away from outside aid, forced to fend for themselves, they clung even more fiercely to the scraps of technology that had been left behind. Survival depended on uncovering caches of abandoned equipment and reviving pre-Rifts plans and designs. Every kingdom had its armory, its gunsmiths and engineers. The most successful eventually became something similar to actual corporations from ages past.

In Northern Michigan, just such an event was taking place. The secluded Upper Peninsula had weathered the magical storm of the Great Cataclysm, thanks to being remote and without many nearby ley lines and nexus points to threaten it. Lightly populated even before the Coming of the Rifts, the Upper Peninsula was undergoing a kind of renaissance of new development and growing population when the Great Cataclysm struck and the Rifts appeared. There was much in the way of high technology to be salvaged, especially at the sites of the region’s former universities and high-tech design and manufacturing companies.

The dwindling survivors of the Golden Age banded together into cities and tiny kingdoms. In one Michigan city, *Ishpeming*, the remains of pre-Rifts mining and manufacturing giant *Northern, Inc.* became the roots of the Two Hundred Years Dark Age weapons producer that would become known as *Northern Gun*. It converted and rebuilt factories and managed to fight off the advances of men and monsters alike. The demand for their products was so great that the factories might as well have been producing gold out of thin air. As the only reliable source of the weapons and vehicles that kept the denizens of the Rifts at bay, Northern Gun became so crucial that they used their position to place corporate sovereignty above that of the local government. The various city-states of the Upper Peninsula were forced to adhere to the dictates of the **NG Trade Council** or lose access to the technology that kept them alive.

Soon, Ishpeming became the seat of the loosely organized Kingdom of Ishpeming. Various “kings” appointed by the NG Trade Council would officially rule, but it was Northern Gun, the corporation, that they served, and continue to serve. NG is the real power behind the central government, and the NG Trade Council is the executive branch. As a result, profits are a state concern and market shares are brought up at every legislative assembly. The adventurers, travelers and refugees who have purchased goods at Northern Gun, and the endless shipments of arms and equipment sent round the continent, have made the company rich and famous.

The rise of the **Coalition States** has done little to reduce NG’s market presence. In fact, many scholars believe that without the pressure of the Coalition on so many of Northern Gun’s customers, NG’s products would not have been in such great demand, nor would it have grown to be the power it is today. Many clients who purchase big-ticket military items, in particular, are looking for something to combat, fend off or compete with the Coalition States. The CS undoubtedly sets the human technological standard in North America, but Northern Gun is at worst, second, and making progress swiftly as it advances countless research projects.

With the **Campaign of Unity**, Northern Gun and its neighbor, *the Manistique Imperium*, both signed nonaggression pacts and limited alliances with the Coalition States. They have entered into trade agreements and now provide certain civilian products, parts and tech to the much larger CS, adding more to their coffers. In return, they have received promises of military defense and support from the CS, as well as technological exchanges that have given them a glimpse of the Coalition’s futuristic wonders.

The alliance with the CS has also had an effect on Northern Gun’s relationship with its traditional customers. As part of the treaty, Northern Gun has agreed to discontinue direct sales and weapons shipments to *Lazlo*, *New Lazlo*, *the Federation of Magic* and other states designated as “enemies of the Coalition.” Of course, this edict has had little or no effect on the secondary resale market, but there has been a noticeable percentage decrease in the amount of Northern Gun products that *kingdoms of magic* have been able to get their hands on. Secretly, the Northern Gun Trade Council does allow shipments to be dispatched to magic-using clients, but never on the books and always with a large degree of subtlety. There are so many intermediaries, wholesalers and middlemen that tracking the ultimate destination of a particular shipment is often impossible. Likewise, a certain percentage is hijacked by Black Marketeers, pirates and mercenaries, and still ends up on the open market. (Actually, half of the “hijacked” shipments are purchased in secret, under the table, from NG.)

All in all, cooperation with the Coalition States creates many more benefits for Northern Gun than it does hindrances, at least for the moment. Nobody believes NG has sold out to the CS, even if Northern Gun does lip service to the Coalition.

The biggest change has been increased pressure on D-Bees and practitioners of magic, which has caused the D-Bee populations to decline by 5.3 percent in Northern Gun’s large cities, especially Ishpeming itself. Few D-Bees have actually left “the republic.” Instead they opt to live unobtrusively in one of Northern Gun’s many smaller towns and keep a lower profile than they once did. Frontier communities of D-Bees or where magic is noticeable have always been part of Northern Gun, and the merce-

naries hired to protect the country rarely harass non-humans or mages.

Outright persecution of D-Bees and magic practitioners at Northern Gun is more theater than real policy. There is more public ballyhoo and displays – as in actual signs, the occasional billboard and public service announcement – about the dangers of D-Bees and magic, but it’s all done with a wink and a nod, and there is little muscle put behind any of it. Everyone but the CS seems to be in on the joke. In short, D-Bees and mages are as welcomed in Northern Gun as ever before. NG is happy to sell to them or, better yet, their human middleman/broker, anything they can afford. Northern Gun just insists it is now done in a discreet manner behind closed doors and away from the paranoid eyes of the CS. Thus, when a visiting Coalition dignitary is in earshot, a D-Bee might be shown his way out the front door with much fanfare and apparent disdain, but sold that very item at *the back door* at a 10-15% discount for his cooperation and inconvenience.



Northern Gun, 109 P.A.

“King and country? Try ‘nation and corporation’.”

If you define fascism as the combination of state and corporate power, one might think that Northern Gun is a fascist state. In reality, however, the corporate elements are so much more powerful than the supposed government, that to call the nation “fascist” is unfair and inaccurate. It is a corporation with territorial holdings and citizens. A series of local governments wrapped up in a large company instead of a federal government. The ultimate “company town.”

During the Dark Age, the industrial centers that provided the weapons and vehicles that kept the invading denizens of the Rifts at bay became so crucial that some used their position to amass great wealth and power. In most cases, they eventually became one with traditional governments, but in Ishpeming, the mighty Northern Gun corporation clung to its sovereignty and enforced its will over the few scraps of local governance that could even attempt to resist it. Armed with a comparatively endless supply of military weapons and ammunition, Northern Gun’s security personnel were the best equipped warriors in the area, and they played a vital part in securing Northern Michigan during the Dark Age.

Even more vital to NG were the scores of freedom fighters, local guardsmen, mercenaries and adventurers who survived by the grace of god and Northern Gun weapons. Guns and gear desperately needed for battles against foes from the Rifts. Without the weapons and equipment provided by Northern Gun, one can argue that humanity on the continent might very well have perished. Before there was a Coalition States and as the heroes of the bygone era of human superiority over the Earth slipped away,

there was Northern Gun offering hope and armaments. Countless cities and human kingdoms would have perished over the long years if not for NG. Many still did. But those able to trade with Northern Gun and acquire precious M.D. weapons, fuel and supplies had a fighting chance.

Though famous for its armaments, Northern Gun has always made and sold basic goods like generators, tools, building materials, vehicles and other supplies that make survival possible in the seemingly endless frontier that North America has become. Even today, outside the Coalition States, Northern Gun is often the only major manufacturer and sales outlet of note (though the Black Market is catching up). There are other arms sellers, to be sure, specialists like Wilk’s, as well as Wellington Industries and the Black Market, but none can compare to the sheer range of products or availability of Northern Gun. And nobody offers the wide range of weapons, combat robots and vehicles.

This position has given Northern Gun virtually unlimited control over the “nation” of Ishpeming. Long ago, every mayor, every governor, minor monarch, gangster and local warlord within the region acquiesced to the power of the **Northern Gun corporation**. With no other source of weapons and ammunition, they were all dependent on the arms giant as a lifeline, and to sever that lifeline would leave them exposed to any number of vile monstrosities or opportunistic raiders. Taxes and tribute were put in place, and before long, the semblance of a state had begun to take shape. All overseen from Northern Gun’s corporate boardrooms. Michigan’s Upper Peninsula had always been a political backwater anyway, and the corporate system that eventually evolved into Northern Gun had enjoyed undue influence over the local political process for years even before the Coming of the Rifts.

Today, Northern Gun is a massive corporation, a political juggernaut and the economic lifeblood of North America. While the Coalition has a much larger manufacturing base and superior technology, no nation or company comes close to Northern Gun in manufacturing, tech, reputation, or number of customers. From the Coalition States to the Pecos Empire and beyond, from mercenaries to practitioners of magic, virtually everyone in North America has heard of Northern Gun and has used their products. Many people from outside Michigan even lump Ishpeming, the Manistique Imperium and the many smaller towns around NG together under the title “Northern Gun,” making no distinction between the neighboring states, much less between the country of Ishpeming and the Northern Gun corporation.

The Republic of Ishpeming. While the Northern Gun corporation is the real power in the western Upper Peninsula, the Republic of Ishpeming is the figurehead nation and official government that rules over the people. Until 107 P.A., it was known as the *Kingdom of Ishpeming*, until the Northern Gun Trade Council changed the name to sound more politically correct. In reality, Ishpeming was never a kingdom or a republic, and Northern Gun’s administration is anything but democratic. The Republic of Ishpeming exists to serve the Northern Gun corporation and better oversee civil affairs. It is what we would know in our time as local government, responsible for civil ordinances, fire protection, garbage removal, water and power, street maintenance and other civic duties. It is the Northern Gun corporation that makes the laws and maintains the police and military, leaving the *Republic of Ishpeming* little more than an empty bureaucratic shell.

Northern Gun has a dominant relationship with the **Manistique Imperium**, its smaller, less developed neighbor. NG has

been a market force for generations, while the Imperium's presence has only really been felt over the last few decades. For though they have been a large-scale manufacturer and provider of natural resources for quite some time, only lately have strong and visible brand names like *Titan Robotics* and *Wellington Industries* begun to appear. The Coalition's influence and the long, undefended border between Ishpeming and Manistique both keep any rivalry friendly, or at least, nonviolent, and the two kingdoms have always been each other's largest trading partners and most staunch allies.

Northern Gun's current priorities are three-fold. Their first goal is to strengthen their ties with the *Coalition States* and develop the alliance into a partnership that is beneficial for Ishpeming/NG, but does not threaten its independence. Northern Gun sees the CS as the major political power in North America, and adapting to their dominance and hegemony will be part of Ishpeming's continued survival.

The second priority is to build up market share. Competitors have been cropping up, particularly over the last decade, and Northern Gun's grip on the North American market has been slowly eroded. In order to make up for lost sales, the NG Trade Council's plan is to get back to Northern Gun's roots. The focus for the future is on preserving the company's share in the market for robots, power armor and adventure gear, and selling more civilian technology and vehicles to state customers like the CS and Free Quebec. To this end, NG is expanding its already famous line of robots, and producing better and more diverse military weapon systems, adventuring vehicles and gear for mercenaries, independent kingdoms and similar clients.

Third, Northern Gun's experience with *Naruni Enterprises* has taught them several things about alien weapons manufacturers. They know that their homegrown technology cannot compare to many otherworldly designs, and have chosen to attempt to *fight* alien rivals rather than try to compete with them. The backlash against the Naruni was heartening to Northern Gun, who enjoys great public relations and customer loyalty. NG was pleased as well with the Coalition's willingness to do most of the heavy lifting in eliminating the interdimensional arms merchants. Should another company like Naruni Enterprises crop up, Northern Gun will be quick to brand them as "alien invaders" and "terrorist sympathizers" and request CS assistance in *eliminating* their vendors and capturing their sales stock. Until Triax develops a consistent trade route with North America or another native manufacturer somehow manages to swiftly expand, Northern Gun will continue to be the premier provider of weapons and technology on the continent.

Overall Tech Levels in North America

While **Northern Gun** is a technological powerhouse and center for research and development, it is by no means the most advanced high-tech manufacturer on the North American Continent, let alone Rifts Earth. In North America, among the human population, **Northern Gun** officially ranks *Number Three* after the **Coalition States** and **Free Quebec**. Many would justifiably argue that NG should be ranked Number Two, before Free Quebec (Erin Tarn is among those who sees NG as Number Two), but that is a debate that has gone on for generations. Certainly the two are very close, as are many on the list. However, there are external, foreign and unknown forces that, when included, would

put all three much lower in the rankings of the technologically advanced in North America.

1. Splugorth/Kittani & Other Splugorth Alien Technology
2. Naruni Enterprises (Advanced alien technology)
3. Archie Three (Golden Age tech improved upon by the A.I.)
4. Triax Industries (Arguably the most advanced human tech)
5. The Republicans (Golden Age technology)
6. Coalition States
7. Free Quebec (ex-Coalition State)
8. *Northern Gun*
9. Manistique Imperium
10. Bandito Arms (a new player in the tech market)
11. Black Market
12. Wilk's Laser Technologies
13. Iron Heart Armaments
14. Wellington Industries
15. Golden Age Weaponsmiths

1. The Splugorth of Atlantis. Though Atlantis is its own island continent, the Splugorth and their weapons and war machines (both tech and magical) are common enough to be included and counted on the tech list of North America. Nobody but the Naruni comes close to their tech level. Thankfully, most Splugorth, Kittani and other alien tech at the Splugorth's disposal has limited availability in North America. In most cases, the tech has to be purchased on Atlantis or procured from Splugorth minions operating on North American soil.

2. Naruni Enterprises. This is a trans-dimensional, alien arms dealer of notorious reputation. The Naruni tech is on par with the Splugorth (some say, superior). They are included on the list because the Naruni have made two efforts to break into the arms market in North America. Because their weapons are so superior and coveted by mercenaries and armed camps, almost all the other weapons manufacturers conspire against them for fear of the competition. Northern Gun, the Coalition, Splugorth and Black Market are all especially diligent and aggressive in "removing" the Naruni from the North American market.

3. Archie Three, rather than Titan Robotics, is on the list at Number Three because the insane A.I. (artificial intelligence) is, itself, a creation from the Golden Age and has at its disposal, not only a vast range of Golden Age knowledge and technology, but its superior manufacturing capabilities via a massive network of underground factories. Without a doubt, Archie Three is in control of the most advanced human technology, having improved and gone beyond Golden Age tech levels. However, the insane A.I. with delusions of godhood doesn't share its tech secrets with others. Only bits and pieces are doled out through **Titan Robotics**, located in Upper Michigan and often mistaken to be a Northern Gun subsidiary by many outsiders. Of course, Archie uses its technological wonders for its own secret machinations for continental domination. (See **Rifts® Sourcebook One** for considerable information about A.R.C.H.I.E. Three, as well as the Shemarrian Nation sourcebook, as Shemarrians are the android creations of Archie.)

4. Triax Industries. Some people may balk at having a foreign country included on the list. However, Triax products are greatly valued and desired in the American market and more and more are being imported into the Americas via Free Quebec, and a grudging Coalition States. Triax tech is derivative of Golden Age

technology and factories that survived the Great Cataclysm and is arguably the most advanced human technology under human control. (Archie doesn't count.)

5. The Republicans are another secret organization with access to Golden Age technology from just before the Great Cataclysm. This super-secret organization also has limited access to Archie Three and the old NEMA factories under the A.I.'s control. The Republicans, like Archie, work in secret, behind the scenes, so they and their tech have had little obvious influence on the Americas.

6. The Coalition States. The CS – Chi-Town in particular – is the reigning technological and military power in North America. They remain consistently 15-20 years ahead in fields like robotics, armor, military vehicles, aircraft, cybernetics, weapons engineering, and communications. CS weapons and all things military are exclusive to the CS Army and not sold on the open market, except for what can be procured by the Black Market and other second-hand arms dealers.

7. Free Quebec, once a member State of the Coalition, is only 10-15 years behind the CS, but puts much of their technology in their old-tech Glitter Boys with some new twists. That said, the fiercely independent and isolationist nation has virtually NO presence in the arms and tech markets, as they seldom make their products available outside their borders.

8. Northern Gun is the premier tech-power that is also a free and independent nation and manufacturer. As such, NG supplies EVERYBODY from towns, cities and kingdoms to adventurers, mercenaries, and criminals. It is 12-15 years behind the CS, but manufactures a vast range of military hardware to commercial products.

9. The Manistique Imperium has always existed in the shadow of Northern Gun and the Coalition States. While not as advanced and flashy as NG, the nation is a manufacturing workhorse, making and selling a wide range of common adventuring and household goods and supplying parts and products to other manufacturers, including Northern Gun, the Black Market, Iron Heart, Wellington, Golden Age Weaponsmiths and others. Manistique is 18-25 years behind the CS.

10. Bandito Arms is listed separate from the Black Market even though it is run by the criminal organization, because it represents a new and distinct level of technology. As a recovered, secret Golden Age military compound, its tech level is only 5-10 years behind the CS and may hold yet undiscovered secrets that could improve upon that. However, this superior tech is limited to SAMAS power armor and some robotics and weapons, providing a severely narrow area of high-tech expertise. Worse, Bandito Arms is very reliant upon the capabilities of the ancient military base, and they don't understand half of what they are making.

NG and most other manufacturers consider Bandito Arms to be a new and dangerous player in the tech market, especially with its Coalition-style SAMAS power armor product line. The CS wants the company's manufacturing facility itself – which they are certain to be a previously undiscovered Golden Age military factory compound. If they can find it, they'll seize it for their own use. Northern Gun and most other competitors would love to do likewise, except such an action would create all-out war with the Black Market, and nobody wants to be on the Black Market's hate list. As a consequence, NG and others ignore the growing market presence and arrogance of Bandito Arms. Of course, there

are many, NG included, who would be glad to locate the manufacturing facility and secretly pass it on to the CS.

11. The Black Market is a major player in the marketplace, but its overall tech level is below the Manistique Imperium; roughly 22-30 years behind the CS. Bandito Arms is the exception and a recent development. That said, as "the Black Market," the criminal organization sells all kinds of contraband and products from wherever they can get them. They also make and sell cheap "knock-off" products of most of the manufacturers listed above, as well as selling some of the actual products of all those mentioned above. In the latter case, such items are likely to be stolen goods or acquired by other nefarious measures. As stolen "Black Market" goods, those who purchase them may run into trouble with the law or the rightful owners. The Splugorth, Naruni, CS, and Northern Gun's LPO try to ferret out bandits and criminals who steal their products and try to sell them to the Black Market. Such brigands generally meet with a violent end.

12. Wilk's Laser Technologies is easily on par with the CS or maybe even Triax, except it is limited to the area of laser weapons, laser tools and other laser technologies and products. This very narrow and specialized range of products makes them a small player with a popular niche.

13-15. Iron Heart Armaments, Wellington Industries and Golden Age Weaponsmiths are all on about the same level and 20-30 years behind the CS. Wellington is still growing into a real corporation, owing its startup and most of its capital to the *Manistique Royal Family*.

Additional Tech Manufacturers:

Angrar Robotics is not on the list because it is barely a player on the tech scene and incorporates dark magic into its very limited designs.

Chipwell Armaments is not on the list because it is a struggling weapons manufacturer that has found itself barely able to compete. It is largely overshadowed by Northern Gun, the Manistique Imperium, the Black Market, and . . . well, really . . . everyone. Though it has managed to stay in business, it is on few people's radar and is not a major player.

Other manufacturers. There are other, small factories and manufacturers, but they are all obscure and/or regional with little or no impact on the weapons market.

Techno-Wizard and other magic weapons manufacturers were not considered for the "tech" list because their creations fall into a completely separate category, and most are relatively low-tech, roughly on par with Black Market or lower tech levels.

Northern Gun Products

The weapons, robots and vehicles Northern Gun produces are tough, rugged and dependable. Each one is thoroughly tested by both Northern Gun's quality control department and years of actual use in the field. Many products are used and tested for months or even years by *Northern Gun Loss Prevention Officers*, privileged mercenaries and *Task Force X troops* before an item is made available on the open market.

Northern Gun weapons might be thought of as the *AK-47s* of the arms market in Rifts North America. They are heavy, solidly-built weapons that will still fire after being dropped, the butt slammed into the side of a monster's head, and immersed

under water or in mud or covered in dirt and grime. Misfires, weapons jams and malfunctions are rare, and most Northern Gun models have been refined and simplified several times over their field-life, making them even more reliable and well designed than when they first premiered.

The newer weapons are a bit lighter than those of years past, thanks to lessons learned from reverse-engineering technology acquired from the Coalition, Wilk's, Triax and other sources. They still maintain Northern Gun's reputation for sturdiness and quality, and some new weapons released by NG's competitors and even the CS, have adopted some of Northern Gun's design features for added dependability.

Northern Gun is also known for its robots and armored vehicles. They manufacture their own versions of many popular vehicles like the *Mountaineer* and *Big Boss ATVs*, as well as a wide selection of body armor, motorcycles, hovercycles and jet packs. Their power armor and robots are the stars of the show, however, and in addition to old favorites like the *Samson* and *Hunter Mobile Gun*, there are new models appearing that should appeal to more mercenaries, soldiers and adventurers than ever before. New hovercraft and aircraft are also on the drawing boards at Northern Gun, and the company is offering a few of its own ships and submarine designs! Northern Gun sees competitors appearing all around it and is responding by blazing ahead with new products and innovations to keep longtime customers happy as well as attract a wide range of new buyers to the NG brand.

Some of the hallmarks of the **NG brand** are the practicality of its products, the military hardware cut and look of its designs and the reasonable price. NG's designs may not be sleek or exotic in appearance, but they are reliable workhorses that a merc can count on under most circumstances. Northern Gun products are the pinnacle of reliability and getting the job done. In fact, one of NG's most popular advertising slogans is, "Sturdy and reliable, like the men who count on them."

Even though there may be more complex and sophisticated alternatives, many mercenaries and men at arms still prefer the ruggedness of **Northern Gun** technology. NG equipment is durable and thoroughly tested, and *always* crafted for maximum reliability and dependability in the field. Northern Gun weapon systems, vehicles and gear are not temperamental and are designed to be simple and easy to use. Weapons can be cleaned and disassembled with little or no training or experience, and are generally heavy enough to be used as a club or blunt weapon. Water, mud, rust damage and barrels scorched by overuse are all but ignored by the average Northern Gun energy weapon.

"*Durable, dependable, deadly*" has been the sales slogan behind Northern Gun small arms for decades, and is still the mantra used by many salespeople.

Vehicles, robots and power armor are also built in the dependable Northern Gun style. While they may not be quite as fast, powerful or as heavily armed or armored as Coalition war machines, they have all the features of durability, dependability, functionality and deadliness NG customers have come to expect. They are much less likely to break down by the side of the road and when they do, they don't require full-blown engineering support to make the repairs like CS robots and vehicles. Northern Gun and most of its customers do not have access to any kind of reliable supply chain, garage or support network, and must rely on themselves and the hardy nature of their equipment to

survive in the field. It is that durability and reliability that has made NG products famous and wanted. Northern Gun's commitment to quality and dependability has saved countless lives since the Dark Age and *everyone* knows it. When backed into a corner, a person knows the NG weapon they have will work under the worst of situations. Demons, monsters and misguided humans alike, have all perished under the namesake products of the Northern Gun corporation.

Non-Contract Employees, the Citizens of Ishpeming

In the eyes of Northern Gun, every citizen of Ishpeming and the other cities of the Republic is technically *an employee* of the company. While they do not receive regular pay and do not hold positions within the actual corporate structure, they are on the books and can be treated just like any other employee by the head office. This condition gives the Trade Council greater control over the people who live in Northern Michigan and asserts the dominance of the company over the state.

Being a **non-contract employee** is quite similar to being a regular citizen elsewhere. Taxes are simply labeled as "corporate dues" and laws become "company standards and regulations." Government workers are paid just like the actual employees of the Northern Gun corporation and many of the mechanisms of state have been combined with the company's management and finance departments.

Compared to many monarchies and dictatorships and the fascist, paternal grip of the government of the Coalition States, life under the Northern Gun's Trade Council and Management Office is actually quite free and just. Northern Gun's relentless concern with profits and market share means micro-managing the citizenry is a foreign concept and a distant priority. The Republic of Ishpeming is certainly a corporate state, but a very libertarian one. The people are generally free to do what they like as long as it does not interfere with the workings of Northern Gun corporate. Besides, the less of a nanny-state that the "Republic" becomes, the more the populace is forced to purchase Northern Gun goods and services in order to take care of themselves.

Employees of Northern Gun

Northern Gun has its own corporate culture and attitude. Its employees are proud of their work and of the company as a whole. Loyalty is fierce and a sense of heritage, importance and elitism over outsiders is ingrained. NG employees and Ishpeming civilians won't say it to anyone's face, but they believe they are better than most people. A shining star in an ugly, brutal and uncivilized world.

Northern Gun's management team tries to instill in them a sense of belonging, camaraderie and purpose. They are working not just for a paycheck, but to provide humanity with the weapons and tools necessary for survival in the hostile environment of Rifts Earth. It may not be on the same level of brainwashed zeal shared by most Coalition citizens, but the employees and citizens of Northern Gun are convinced they are making a difference in the world and are on the side of progress.

Northern Gun takes good care of its employees. With over 100,000 of them, there has not been a corporate entity in America of such size since before the Coming of the Rifts. With such a



vast number of employees, Northern Gun's amalgamation with the *Republic of Ishpeming* is very beneficial. The company has its own territorial reserves and does not need to negotiate with a host state or kingdom. Its resources and those of the Republic are one and the same, and Northern Gun owns its mines and factories and pays nothing for the ore it extracts from the ground other than labor.

Considering the nation and the company are basically one and the same, official, *contract employees* (those who actually work for NG) enjoy a kind of super-citizen status. While D-Bees are kept out of sight and sometimes oppressed, D-Bee contract employees are treated as equals within the company and receive special and preferential treatment within the country. All NG contract employees are often allowed to skip lines and skirt regulations, receive free goods and discounts, get free medical benefits and discounted corporate housing, and are generally shown greater lenience by law enforcement and mercenaries on garrison duty. A Northern Gun employee I.D. card carries nearly the same weight as a police badge or government position would in most other kingdoms. One reason is the zealous loyalty of all NG employees and the fact that all are truly dedicated to serving and protecting the company, maximizing profits and promoting the NG way of life.

Pride and Corporate Culture. The people of Ishpeming and the contract employees (citizens) of Northern Gun, in particular, take a vast amount of pride in their nation's reputation as the continent's premier manufacturer. The NG brand name is everywhere, and outsider products are frowned upon. That young NG executive who wants to show off with a brand new Triax hovercar may find it keyed, vandalized or worse, and certain corporate buildings actually have separate, fenced-off parking lots for anyone who drives a non-NG vehicle – for their own safety, of

course. Even citizens of Ishpeming who do not work for NG usually refer to themselves as living in, or being citizens of, “Northern Gun” rather than Ishpeming. Northern Gun is the name they identify with. Likewise, 77% of people outside Michigan say they have never heard of the nation of Ishpeming, but they *all* know Northern Gun.

There are many kingdoms in North America that use Northern Gun products almost exclusively. All-encompassing deals are available and when they are accepted, a kingdom is flooded with NG products, from large vehicles and weapons to simple things like boots and batteries. Most NG goods are cheaper the closer one gets to Ishpeming as well, and the highly active *resale market* for NG products means that used or re-manufactured products are always available to those who cannot afford to shop brand new. Northern Gun is also willing to lower prices and offer flexible terms, especially to kingdoms, cities and mercenary groups that aren't yet NG customers. Everything is about expanding market share and getting people hooked on the Northern Gun brand name.

The people of Northern Gun take great pride in being known across the land for their products. The **Northern Gun** “brand name” is known for being sturdy and reliable, two traits the people of Ishpeming see in themselves. NG's reputation is their reputation.

Indeed, most citizens of Ishpeming are hardworking, strong, honest, no-nonsense, straight-talking individuals who take tremendous pride in their work. They are more concerned with substance and functionality than fancy flash and style. This has caused some NG competitors to criticize the sometimes boxy, military hardware look of NG products, but even their harshest critics have done little to impact the company's sales or reputation. When you want a product you can count on, you turn to Northern Gun. The citizens and workers of NG love that reputation and wear it like a badge of honor.

NG Factories & Manufacturing

The heaviest, most dangerous and repetitive grunt work of manufacturing and building is done by robots and labor drones. Light and heavy labor robots are used to move cargo and heavy objects, perform construction tasks, operate assembly lines and work inside factories. An estimated 97% of the robot drones used at factory sites are powered by *electric* and *Solid Oxide batteries*; the much more expensive nuclear models are reserved for sale to customers without access to reliable power supplies and recharging facilities. Nuclear power supplies were a breakthrough during the Golden Age of Humanity and created mainly for military and special duties that required extremely long service periods. This old military technology is one of the few technological triumphs that survived the Great Cataclysm and is used by almost every high-tech manufacturer on Earth, Northern Gun included. They are ideal for long stints in the field and adventuring through the wilderness across the globe, as well as supplying the energy needed by energy weapon systems. *Human beings* supervise the robots fairly closely and sometimes wear industrial exoskeletons or power armor, or pilot robot vehicles themselves.

In factories, parts are cast, electronics bundles threaded through them, and then whole frames are soldered and lasered together, ready to be finished off with weapons, extra equipment and armor plating. Quality control testing is important, especially

with military weapons and systems that will be used in combat and wilderness survival. NG's designs are so robust and redundant, though, that quality control rarely finds defects. The bored, lazy quality control agent with nothing to do has become a running joke within the corporation's manufacturing division.

The most creative, complex and less repetitive tasks, including industrial design and engineering, as well as light factory work and assembly line production, are performed by Northern Gun's human and D-Bee labor force, with the latter doing most of the hardest and least rewarding work.

Northern Gun employees are well paid, especially by the standards of other communities throughout Rifts Earth. Surprisingly, Northern Gun factories use less automation than the Coalition States or Free Quebec, so they can employ a larger number of 'live' workers per factory. Blue-collar employees and low-level managers and specialists make up the middle-class of Ishpeming, and a whopping 63% of the population is considered middle-class. It is a slice of the population that is fairly tight-knit considering they all work for the same company. Only 20% of the population is considered low income, 6% poor (less than 2% unemployment) and the remaining 11% are wealthy. Many of the so-called independent machine shops, small manufacturers and businesses do work for or related to NG products. One could even argue that most of the entertainment and hotel business is ancillary to Northern Gun. All NG workers, even D-Bees, are compensated well for their labor, and the promise of a steady job is enough to draw some of the best and brightest in North America. All of this makes Northern Gun one of the most stable, safe and wealthy nations on the continent.

Keeping its employees happy ensures reliability. And reliability is how the Northern Gun corporation makes its money. In a world where instability and strife are the only constants, many turn to Northern Gun because of the consistent quality and reliability of their products. The Black Market and small weapons makers cannot compete with Northern Gun's reputation and supply chain. Speaking of the Black Market, the organization's presence in Ishpeming is minimal.

Northern Gun Policies

Northern Gun's Policy on Magic

Its overall laissez-faire attitude is reflected in Northern Gun's policies towards magic and Dimensional Beings (D-Bees). In both cases, they are "officially" illegal, yet both exist in Ishpeming and throughout the Michigan peninsula, and are mostly ignored. For example, magic is officially outlawed, yet there is nothing close to the war on magic found within the Coalition States. As long as the use of magic isn't seen or heard, and doesn't cause a public commotion or complaints, **Northern Gun Loss Prevention Officers (NG-LPO)** are in no hurry to investigate claims of incidents involving the "possible" use of magic.

The scarcity of ley lines and nexus points within the peninsula also means that incidents involving magic and dimensional threats are much less common than in other parts of the world. Groups of magic practitioners have sprung up, especially in the frontier areas and smaller cities around Ishpeming, but they remain discreetly in the shadows, avoid attention and are few in numbers compared to most other communities. Another reason

there are so few practitioners of magic is there is little to attract them to a place like Ishpeming and Upper Michigan. The communities there are mainly centers for technology. Its citizens are blue-collar factory workers and technophiles whose outlook on life is widely seen as inimical to the mystic arts. In short, there is little interest or need for magic. There are a few scientists, techs and designers who find the idea of **Techno-Wizardry** intriguing, but there are no TW manufacturers nor any desire to get into that line of work.

As a result, TW manufacturing is outlawed and the NG corporation fires any employee they discover who dabbles in any sort of magic. As the largest and best paying employer in the region, this alone has been an effective deterrent to the practice of magic. The people of Upper Michigan are doing well and nobody wants to rock the boat. Besides, from their point of view, who needs magic? They are proud, independent "techies."

As with most policies and practices at Northern Gun, these laws and regulations are not a bias against magic, but rather a business decision. NG has a sweet thing going for it. The CS has embraced them as an ally. Business is booming. They are making and selling more products than ever. The community is one of the safest in North America and the majority of citizens are healthy and happy. Why get entangled with the unknown aspects of magic or invoke the Coalition's disapproval (and wrath) by developing a line of magic products or embracing magic practitioners?

Of course, many misconceptions about magic prevail in and around Ishpeming/Northern Gun. Most citizens believe a lot of the Coalition's propaganda, especially the parts about magic defying the laws of science, that it is unstable, that it corrupts the minds and souls of its practitioners, and that magic is unpredictable, alien and dangerous. However, while Coalition citizens fear and hate magic, Ishpeming/NG citizens take the pragmatic view of: if magic is dangerous and we don't need it, let's keep it out of our lives. End of debate. And most people throughout the tech-savvy Michigan Upper Peninsula share that view.

Visitors who practice magic may be viewed with varying levels of concern, but are not Boogie-men or enemies to be instantly feared, hated and destroyed. That said, NG defenders take a hard line with practitioners of magic. Any mage, even when he does not have conventional weapons on his person, is considered "armed and dangerous," allowing the authorities and defenders to use *lethal force* without hesitation or recrimination. This also holds true of anybody who kills a mage in "self-defense," because he is armed with magic and could have been in the process of casting a spell of unknown consequence. Since magic is an unknown quantity, the rule of thumb is, it is better to be safe than sorry. Extreme force and lethal responses are common against anyone able to cast magic or wielding magical devices. *Loss Prevention Officers* have been trained to recognize Techno-Wizard devices and practitioners of magic. When TW and magic items are recognized, they are to be confiscated and destroyed, and the owner subject to possible arrest or, more likely, a small fine and a stern warning. And no, the magic device is never returned to the individual when he leaves town. Remember, most people, including the law, may look the other way, but *magic is illegal* in Ishpeming. Those who get a magic item(s) confiscated and have to pay a fine should be happy that's the only consequence they have to face.

Note: Confiscated TW and magic items may be studied. A few may be kept on hand for further analysis and some are used in

covert operations against the supernatural and creatures of magic by NG operatives. Half, however, are turned over every quarter to their CS ally to keep them happy and convinced that Northern Gun is doing its job to stop magic. It is assumed such items given to the CS are destroyed. Some are, but many go into the legendary **Black Vault**. The remaining magic contraband collected by NG is quietly and unofficially sold or traded to the Black Market.

It is widely known to Techno-Wizards, mages and adventurers in the possession of magic items, that they should leave their mystical devices at home, or at a secret location *before* entering Northern Gun or any community in the Upper Peninsula. NG is a Techno-Wizard's dream come true and a shopping bonanza for all kinds of tools, parts, used equipment and second-hand guns and gizmos that Techno-Wizards use as the base for their magical creations. And often at bargain prices. Precious and semi-precious stones, an ingredient in many mystic ceremonies and TW items, are also available at Northern Gun. Prices are generally 10-25% lower for such stones than the standard market list prices, as Ishpeming has many active mines and the entire area has become a regional center for mining and ore collection. As a result, Techno-Wizards and mages are frequent and regular customers. They just need to leave their magic items outside the community, keep a low profile, and not allow themselves to be provoked into using magic even in a conflict. Otherwise, it may be their last visit.

Northern Gun Policy on D-Bees

Dimensional Beings (D-Bees) occupy a legal gray area within Northern Gun and most Northern Michigan communities. While they are not technically considered "non-contract employees" (citizens), there are populations of D-Bees living on the peninsula and within Northern Gun communities (and even NG itself). They are never portrayed in Northern Gun commercials and are kept out of all footage aired in the Coalition States, but D-Bees, especially those who are good customers, are not viewed as monsters or as a threat to Northern Gun.

Second-class citizen is a good term to describe D-Bees inside the Republic of Ishpeming and the Northern Gun corporation. They are not allowed to run for public office, serve within the Northern Gun management branch or hold officer rank within the **IMCN** (Ishpeming Military Contract Network). Most are relegated to menial jobs and often see themselves pushed to the outskirts of NG communities or crammed into specific districts and known D-Bee neighborhoods. They are not recognized by the state, cannot become citizens and are politically disenfranchised, but there are no shopkeepers who are willing to flat-out refuse a sale.

Some D-Bees contribute to their "lost-between-the-cracks" place in Ishpeming, because a large percentage of the D-Bees living inside Ishpeming's borders are perfectly happy to go unnoticed. Many are refugees fleeing the Coalition or other human-supremacist kingdoms and are quite content to have found a place in a relatively safe and stable nation such as NG. The Northern Gun corporation is willing to turn a blind eye to D-Bee labor and remote settlements, but can only do so as long as the Dimensional Beings involved don't make trouble. Occasionally, the Loss Prevention Office makes D-Bee rights activists disappear, but more often they are simply intimidated or encouraged to move to Manistique or anywhere but there.

For human-looking D-Bees or those who know how to keep their heads down in public, Northern Gun is remarkably tolerant

and complicit in keeping them under the radar. For many years, Northern Gun had an "all-customers, no-exceptions" policy that extended to all non-supernatural beings. Many NG/Ishpeming citizens and employees are D-Bee sympathizers who have never been exposed to the kind of hate or fear found in the Coalition States, and are happy to help D-Bee customers even if it may be against regulations. However, D-Bees are often required to enter shops through the back door and to be discreet inside shops and at workplaces. D-Bees might stand out a bit at midday in the middle of the public market, but at night and in the periphery of major cities, they are usually able to go on their way without harassment, even by the Loss Prevention Officers or racist mercs. Many small towns and minor cities in the Upper Peninsula are even less prejudiced and D-Bees enjoy many to all the same rights as human citizens. Granted, these rights are not secure and may be taken away at any moment, but most D-Bees have nothing to fear if they avoid drawing attention to themselves.

Out in the small farming towns, logging camps and fishing communities, non-human species are even more intermingled. Entire villages of D-Bees can be found near the Wisconsin border, and D-Bees are not uncommon in the backwoods of central Ishpeming either. Market Towns like **Escanaba** and **Menominee** see so many visitors that it is impossible to filter out all the D-Bees, and unless they are particularly terrifying or disruptive, they are treated as any other customer. Northern Gun is happy to have their business, especially if it can claim total ignorance and maintain a good face for its relationship with the Coalition States.

Spies, Theft & Corporate Espionage

Many divisions of Northern Gun, and most retail outlets, are honest, hardworking and care about their customers, be they human or not. Others seek any opportunity to expand the company's market share and are willing to go to extreme lengths for the Northern Gun corporation. The latter includes espionage, back-room negotiations, shady deals and strange bedfellows.

NG is, arguably, the largest employer of Freelance Spies, Professional Thieves and similar covert agents in North America. There is the CS, of course, but nobody knows how many operatives "outside" the CS military are hired for covert ops. The *Federation of Magic* is even more secretive of cloak and dagger operations. The *Black Market* is the only other organization that comes close to NG, but is seldom included in such estimates because it is an open criminal enterprise, not a legitimate business or an established nation. Northern Gun, on the other hand, hires "independent operatives" for everything from national defense to spying. Mercenaries, spies, thieves and other "freelance" agents are hired to keep an eye on their rivals (including the Black Market and CS) and to engage in what is commonly called "active intervention."

Active intervention can include any of the following: Surveillance and data theft to find out about new products, product releases, release dates, prices, sales data, and marketing strategies, as well as the theft of new prototypes, product designs and concepts, stealing away suppliers and distributors, hiring away executives and technical specialists, sabotaging competitors' research and sabotage of all kinds – though nothing that results in loss of life, just loss of sales, market, and product or that causes delays and problems in the marketplace. Reverse-engineering competitors' products is another common practice. Anything to



keep an edge over their rivals, shy of actual physical violence, extortion, blackmail and serious destruction of property is acceptable. The theft or destruction of a computer or set of blueprints, or a prototype, or even a small office fire or sabotage done to a prototype that causes its wiring to burn out or computer system to go haywire doesn't count. But anything more serious is a no-no. Northern Gun *always makes it clear* that murder, violence, extortion, threats and acts of destruction and terror are not desired nor tolerated. If a hired agent goes too far, or even causes accidental death or destruction, his contract is terminated and he will NEVER be hired by NG again. This may also apply to his teammates and associates even if they remove him from their group or keep their distance. NG has high standards and strict policies they expect their hirelings to uphold. Fail to do so, and you are out. Still, there are different lengths to which the company is willing to go depending on how badly its corporate officers want a particular technology, and the level of risk associated with its acquisition.

Advanced alien equipment is preferable in many ways. Alien tech has the potential of being beyond Northern Gun's own technology and, as an item that has been Rifted to Earth, there is not likely to be a manufacturer or community to complain about any features or tech NG may lift to incorporate it into their own new designs. While other companies in North America may attempt revenge or some sort of legal action against Northern Gun, alien merchants, D-Bees and invaders have no place on Rifts Earth, and no legal resources at their disposal. Even the well-equipped and well-funded **Naruni Enterprises** were essentially helpless when Northern Gun managed to convince the Coalition States the Naruni were a *priority threat*. The Naruni simply cannot get enough people or products to Rifts Earth to carve out a niche for themselves. And getting one's hands on examples of Naruni tech was easy for Northern Gun. To procure the alien weapons, all an

NG agent had to do was go to the right Black Market hub or Naruni sales rep and purchase them like any other customer, or keep an eye out for visiting mercs and adventurers who had stumbled across "something unusual." Of course, much of the Naruni tech is beyond NG's understanding and manufacturing capabilities, but that doesn't mean the company can't learn from it, get ideas or figure out new designs from studying the alien tech.

Stealing ideas and designs from companies like **Wellington Industries**, **Golden Age Weaponsmiths**, **Iron Heart Armaments** and even the **Black Market** and various **Manistique Imperium** companies, is easy since these companies have sales outlets and manufacturing operations located relatively close to Northern Gun. However, while the occasional design and idea is hijacked, these companies are more likely to try to steal NG designs than the other way around. In most cases, the companies named manufacture pedestrian designs that are more simple and less advanced than Northern Gun. In short, they don't offer much that interests NG. Most of their products can be purchased on the open market and use the same, or lower, level of technology.

Companies like **Wilk's**, **Titan Robotics**, **Triax**, some **Black Market** gear (especially many of the new products coming from **Bandito Arms**) and the **Coalition States'** technology are another story. Many of these weapon and vehicle designs are more advanced than Northern Gun. As such, they are inspiring goals to aim for and tech to emulate. Stealing their designs via reverse-engineering, however, is a much more delicate prospect and tricky operation. If caught, there can be serious repercussions. The least of which can result in damaging publicity, turf wars with escalating acts of retribution (legal and illegal), sabotage, price wars, and other things that can injure a company and hurt sales.

What some people don't realize is that all of these industrial kingdoms and companies have grown to power because they happened to possess a handful of the pre-Cataclysm designs and the manufacturing capabilities/factories to make them. This edge helped them grow into a political, military or commercial power. Free Quebec had Glitter Boy technology, Wilk's had superior laser weapon technology, Northern Gun, a wide range of weapons, robots and vehicle tech as well as impressive manufacturing capabilities (factories, machine shops, etc.), while the Coalition States had both manufacturing and many NEMA and US military designs available to them, including the SAMAS, making them the most powerful military and tech power in North America.

Having designs is not enough. A community or company also needs the manufacturing capabilities, and without them, mass-producing the product may not be possible. In each of the examples above, the group had the technology, designs and manufacturing capabilities. Secrets and manufacturing plants that were hidden and zealously guarded. For example, there is no other nation in North America that can manufacture a Glitter Boy than Free Quebec. Likewise, until the Bandito Arms SAMAS-style power armor hit the market, only the CS had the SAMAS in their arsenal. This is why the CS has freaked out over Bandito Arms' obvious SAMAS designs hitting the open market. Not only does it put the SAMAS in the hands of enemies and rivals, but it also means Bandito Arms has access to one or more rare, USA/NEMA military manufacturing facilities, and the CS wants it for themselves.

Knocking off, stealing and selling the weapons and equipment of the **Coalition States** is the most dangerous. While Coalition gear does find its way into the hands of the Black Market and

Northern Gun, the latter has no desire to put their alliance with the CS at risk by being caught using their designs. Even NG's new **Red Hawk power armor** may be pushing their luck, and the NG executives know it. If the CS should come down on Northern Gun, the company is prepared to pull the power armor from the shelves, destroy existing inventory and stop its manufacture. A fact that is known through the grapevine on the street and is fueling tremendous sales. NG plans to defend the product as a way to counter the soaring sales of Bandito Arms SAMAS.

Studying **Triax technology** is a less dangerous proposition, but NG is respectful of the political ties and awkwardness between the New German Republic and the Coalition States. They do not wish to antagonize the CS by angering their German associates. Still, Europe is far away, and older Triax designs are examined and design elements "borrowed" with little fear of repercussions at this time. Stealing other people's technology is tricky business.

Policy on Reverse-Engineering

One of the ways the Northern Gun Research & Development branch stays ahead of its more mundane competitors is by reverse-engineering sophisticated foreign, alien and pre-Rifts artifacts. Even amongst normal, human corporations there are specialists that Northern Gun can learn from. **Wilk's lasers**, **Wellington's** missile and grenade launchers and **Iron Heart Armaments'** aircraft can all be found in the reverse-engineering labs being disassembled and closely studied. Coalition States and Triax equipment is kept in *secure vaults* and dissected, in secret, by special teams working under oaths of secrecy. Studying the Coalition's original weapons lineup like the *UAR-1 Enforcer* and classic *SAMAS* (decades before their alliance) gave Northern Gun a boost in their tech level, but *new post-Campaign of Unity* equipment is still a sensitive issue and NG would prefer it if the CS remained unaware of their efforts to learn new tech secrets by reverse-engineering their newest weapon systems.

Throughout their history, the reverse-engineering labs of Northern Gun have dealt with many strange and miraculous pieces of technology. Techno-Wizard devices that defy the laws of physics have passed through the labs, as well as alien artifacts that used principles far beyond their understanding. Moments of wonder and profound joy unfold as *Splugorth weapons* are disassembled to free the Faerie Folk trapped inside. An operation to pick apart an *Angrar robot*, however, released something much worse. The disassembly had to be cancelled as a demon somehow concealed inside burst forth, killing the technicians and requiring the lab to be locked-down and cleared by psychics and an "exorcist." The reverse-engineering labs' overseers were never able to determine how the demon managed to inhabit the robot without being noticed, and the *Angrar combat robot* itself was destroyed completely.

Most perplexing, however, are the amazingly effective anti-tamper devices built into the products of *Titan Robotics*. Every attempt to reverse-engineer Titan robots or power armor has led to failure and activation of a sophisticated self-destruct mechanism, in some cases killing or injuring the technical crew! Rather than put a full halt to their efforts, the Trade Council has mandated that all further reverse-engineering attempts made on Titan products are to be conducted using robots and remotely operated tools. They have even gone so far as to hire psychics to use their

abilities to "read" Titan machines. Strangely enough, even this method has been unable to produce much useful information.

However, a single Titan Reconnaissance Robot under study in 107 P.A. saw a malfunction in its self-destruct system. Northern Gun was able to study the robot for nearly an hour before the destruct mechanism kicked in unexpectedly, destroying the robot and injuring three engineers. All they were able to glean from their brief look was a respect for the incredibly complex arrangements of wiring and circuitry inside the robot, and a kind of self-diagnostic sensor system that was probably installed as an advanced prototype. This has led them to suspect that Titan Robotics may be using *alien science* and technology or some other source of advanced knowledge. This has also made Titan the target of increased espionage efforts and spying. If NG can find enough evidence of alien technology in Titan products, they will notify the Coalition to investigate further and destroy the company and its inventory.

The Reverse-Engineering Labs

Most of Northern Gun's reverse-engineering efforts take place at the main reverse-engineering labs located in Ishpeming. The kind of shadowy projects that the labs work on must be kept secret, and are isolated from normal research efforts. Hidden beneath an ordinary looking corporate office, the labs are one of the most secure sites within the entirety of Northern Michigan. Samples of Coalition and unknown/alien tech are secretly brought to the labs to be picked apart, studied, tested and copied.

There are objects kept in the labs that are so advanced it will take decades to even understand how to study them, much less actually recreate the designs. Naruni force fields, inertia beams, and exotic Atlantean technology are all very different from the common devices found on Rifts Earth. While advanced creations of man may seem astounding, there are alien creations that border on the magical, with capabilities and features seemingly beyond the explanation of science. Even when unknown/alien tech is beyond their own understanding or defies replication, their study may give NG technicians and scientists new ideas of their own or suggest new principles and applications to investigate.

The labs are divided into three levels. Alien artifacts are kept exclusively in the massive, secret sub-basement along with any Coalition and Triax equipment currently being studied. The second level is for priority projects like foreign designs that have somehow found their way to Northern Gun, as well as new releases from North American competitors. The exploded remains of Titan Robots can be found here, as well as bits and pieces from companies like Wilk's and Bandito Arms, and even some far-away places like ArmaTech in Japan, or the Republic of Colombia in South America, or Kitanni items from Atlantis. The top level is the minimal security area, a repository for run-of-the-mill weapons, modified and customized versions being tested, and maybe a few things that haven't been recognized as valuable enough to be moved to a more secure lab.

Jason Mendoza, Head of Reverse Engineering Department, Quick Stats: R&E is an "unofficial" and Top Secretive Northern Gun department, which is just the way Jason likes it. **Alignment:** Unprincipled. **Attributes:** I.Q. 23, M.E. 14, M.A. 13, P.S. 15, P.P. 23, P.E. 14, P.B. 10, Spd 8. **Experience:** 14th level Operator with a number of cybernetic implants to help him in his work.

David Waller, Chief Weapons Theorist & Engineer, Quick Stats: Dave is Mendoza's go to guy when it comes to alien and "weird" gizmos. The two are good friends. **Alignment:** Scrupulous. **Attributes:** I.Q. 25, M.E. 10, M.A. 10, P.S. 12, P.P. 18, P.E. 15, P.B. 11, Spd 10. **Experience:** 12th level Rogue Scientist with a number of cybernetic implants to help him in his work.

NG Research & Development Branch

The earliest Northern Gun products were all designs that were salvaged in the opening days of the company's history: Golden Age weapons and technology pulled out of the ruins by eager scavengers as well as a number of towns, factories and a couple military bases that survived the Great Cataclysm. Some of the company's most notorious equipment came into being this way, with systems still in use, like the *Samson power armor* (originally designed for the Canadian military), *Hunter Mobile Gun*, *Labor 'Bots* and various vehicles and small arms for the US military. But in the last few decades, Northern Gun has grown out of its dependency on recovered Golden Age plans and documents to manufacturing a greater and greater percentage of its own, original designs. (Or derivative designs with new elements and features incorporated from several sources with NG's own spin on things.) This has led to an increasingly military hardware styling and emphasis on practical form and function.

In order to come up with these weapons and vehicles, the Northern Gun corporation maintains an extensive research and development division headed by **Federico Franceschi**. Federico answers only to Jon Kaminsky, the Research & Development Councilor, and the CEO and the President of Northern Gun. This gives Federico a wide degree of latitude in creating new weapons, robots, power armor and combat designs. Though one might expect rivalry, Federico and Kaminsky are like minds who get along with each other very well.

NG research used to be based out of the old R&D labs located beneath the pre-Rifts headquarters of *Northern, Inc.*, but were moved to their own dedicated industrial complex almost twenty years ago. Located deep within the Ishpeming corporate district amidst miles of factories and warehouses, the **NG Research and Development complex** is one of the unknown marvels of Rifts Earth. Inside, mock-ups of new Northern Gun designs are put to the test as engineers and technicians explore the designs' physical limitations. Old units are often used as a base and as test platforms, mounting experimental weapons and features. Everything from standard crash-testing to mixed-terrain capability and resistance to various types of damage is worked out within the R&D labs. NG does not have the technology level of their Coalition States or Triax counterparts, but Northern Gun's facilities are run with a surprisingly open-minded and "can-do" attitude. Many on-the-spot improvisations and upgrades worked out by the lab's Operators, scientists and engineers are later built into production models. When they feel they need "real" field testing, they turn to a large number of known and trusted mercenary and adventurer groups to run the new design through its paces out in the wilderness. Such reports of strengths, weaknesses and suggestions serve to improve and fine tune the new designs.

Anything that can improve Northern Gun's products will be considered, and hefty bonuses are handed out in return for good ideas. Likewise, the subcontracted field-testers are often given the opportunity to purchase the first models to roll off the assembly line at a 50% discount, and sometimes the most helpful are even allowed to keep the imperfect prototype "test model" as a bonus for their services, should they be interested in keeping the unit.

Federico Franceschi, Director of Research and Development, Quick Stats: Federico is a dedicated gear-head who eats, breathes and lives for the development and creation of new NG tech. **Alignment:** Scrupulous. **Attributes:** I.Q. 26, M.E. 14, M.A. 17, P.S. 13, P.P. 15, P.E. 12, P.B. 14, Spd 9. **Experience:** 15th level Rogue Scientist with a focus on robotics, armor and weapon systems.

The Research & Development Complex

Level One of the Research and Development complex is the vast **Weapons Development Center** headed by *Benjamin Barton*. Virtually every new Northern Gun pistol, rifle and heavy weapon design from the last twenty years has come out of this magnificent testing range. Many of the standardized weapon systems used on robots and vehicles are also created here. Hundreds of armorers, weapons experts, engineers and scientists put in long hours to make sure that Northern Gun weapons work well under every imaginable condition. A large portion of the weapons development center is devoted to product-testing, and after the weapons are designed, they are thoroughly put through their paces. The end result are guns with superior reliability and long performance lives, perfect for the heavy use, inconsistent maintenance/cleaning and harsh environmental conditions that most endure in the outside world.

Benjamin Barton, Chief of Weapons Engineering, Quick Stats: **Alignment:** Scrupulous. **Attributes:** I.Q. 20, M.E. 12, M.A. 17, P.S. 14, P.P. 19, P.E. 14, P.B. 13, Spd 10. **Experience:** 12th level Techno-Headhunter with numerous weapon systems built into his bionic limbs. He also has a personal collection of firearms and access to the NG collection which he has helped to build. Both are impressive, but the latter has virtually every firearm and energy weapon that has ever reached the shores of the Americas. Including some alien and magic weapons.

Level Two is the even larger **Vehicle Development Center** which includes a wide range of conventional and robot vehicles. The automotive division, including hovercycles is headed by President of Automobiles, **Douglas Rood**. Top among his army of automotive and combat vehicle engineers and designers are **Warren Nelson, Nick Krupar, Steven Schlosser** and **Trevor Morehead**, each of whom runs his own crack team of designers and engineers.

The Center is connected to the surface by a dozen massive elevators, where full-sized combat robots, tanks and vehicles of every type appear and disappear into the depths of the labs. Inside cavernous testing chambers, vehicles are put to the test until they are deemed ready for field use. Giant treadmills and conveyor-belt climbing walls are part of the facilities, as well as hot and cold rooms for temperature tests and other specialized equipment testing.

Loss Prevention Office

The most shadowy branch of Northern Gun, the mysterious Loss Prevention Office (LPO), is a combination intelligence agency, police force and paramilitary organization. They monitor the citizens of Ishpeming, its visitors and the customers of Ishpeming/Northern Gun. The LPO basically runs a small standing army of spies and “secret police” that ensures the Northern Gun corporation maintains its grip on Ishpeming and the North American sales market.

When the Naruni arms merchants were first declared a threat, it was the Loss Prevention Office (LPO) that leapt into action. The aliens were monitored and several undercover agents were sent in to purchase products. Some of these purchases went to the reverse-engineering labs for secret analysis at Northern Gun, while others were delivered to the Coalition States as proof of the threat posed by the Naruni. Loss Prevention Officers worked side by side with *Coalition Special Forces* and the *ISS* in hunting down, arresting and wiping out as many Naruni personnel as they could find. They continue to look for Black Market agents and oblivious middlemen who sell Naruni Enterprises equipment, sometimes warning them against their current course of action, sometimes placing them under arrest, and sometimes killing them on the spot.

The Loss Prevention Office’s time is split between defending the market presence of the Northern Gun corporation and maintaining its control over the Republic of Ishpeming. There have been few independence movements amongst the city-states and lesser settlements that comprise the whole of Northern Gun. Much of this is due to the level of prosperity shared by most citizens who don’t want to lose a good thing. However, the LPO exerts subtle pressure and takes quiet, covert measures to keep dissenters quiet and troublemakers “pacified.”

The Loss Prevention Office is resented, feared and hated most within the **Manistique Imperium**. While relations between the two countries have always been generally good, the LPO is known to have used its pacification measures, industrial espionage and technology theft within the Imperium for decades. As a result, some within the Imperium resent Northern Gun on many levels and believe the corporate nation has taken deliberate steps to keep Manistique in its shadow and under its thumb.

These days, such LPO practices are generally confined to corporate rivals and alien threats, not other kingdoms. The two companies on the LPO’s radar are Bandito Arms and Titan Robotics. The LPO sees Bandito Arms as a threat to its dominance in the weapons and robotics market, and since they know the CS is gunning for them, is quietly trying to find information they can pass along to the CS to cripple or destroy their operations. Meanwhile, the LPO is suspicious of Titan’s technology and infrastructure. They suspect the company may have affiliations with aliens and has begun a covert investigation of the company, its practices and management.

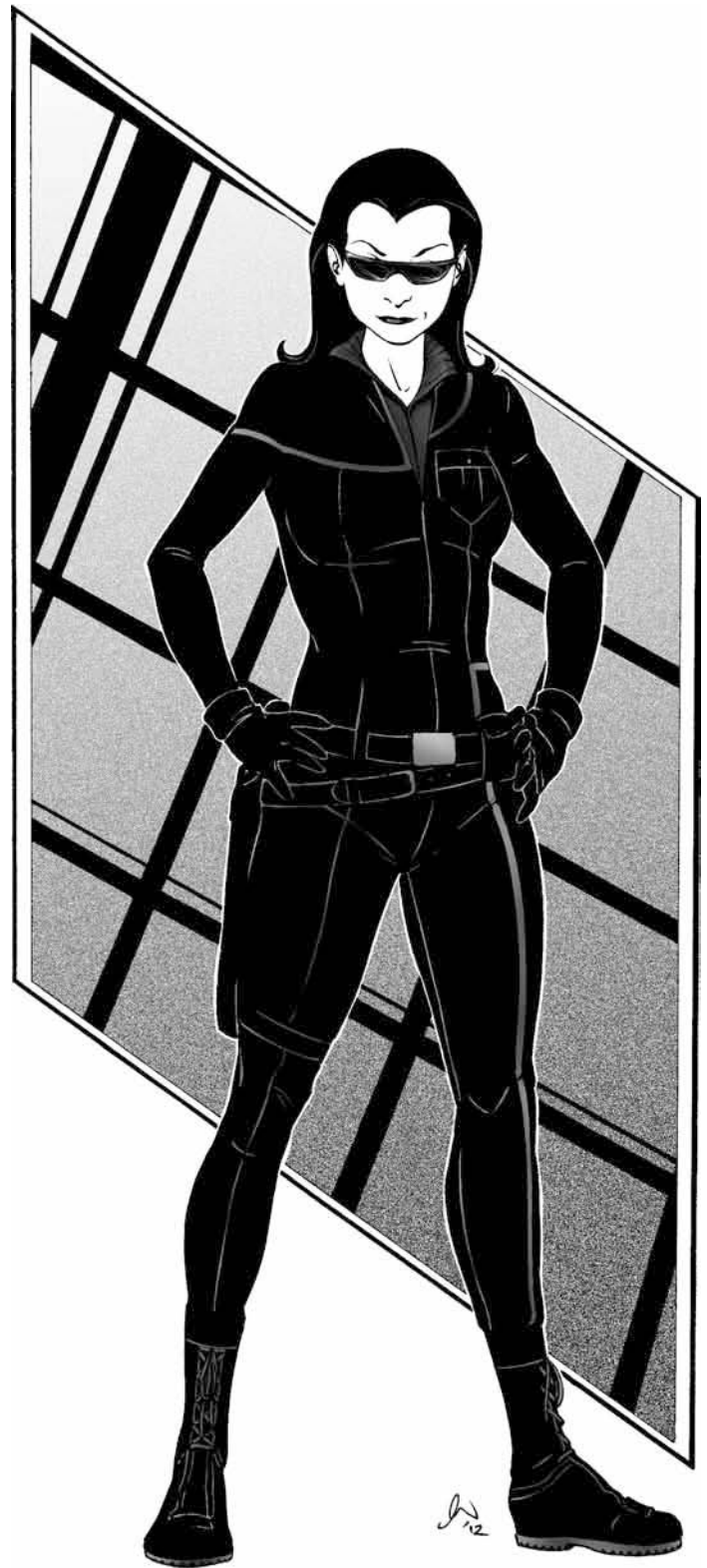

Andrea Callister, Chief Loss Prevention Officer

Andrea Callister is the somewhat notorious, current head of the Loss Prevention Office (LPO). Despite the secret nature of the organization, Chief Callister’s reputation as the spymaster and ranking enforcer of the LPO has spread throughout the country. It is her job to seek out rebels, rivals, spies, enemy operatives, pirates, raiders and smugglers to protect Northern Gun, the cor-

poration and the nation. This includes corporate rivals, foreign threats and agents from competitors like Naruni Enterprises. Chief Callister presided over the Loss Prevention Office (LPO) when the Naruni were effectively wiped off the map, and won a lot of respect and political capital from the NG Trade Council for her swift and decisive actions in the matter. She also has a good reputation and rapport with officials within the CS military, particularly the CS Intelligence Division.

These days, Chief Callister is content to run “the Office” like her own personal fiefdom. No higher-ups bother her nor tell her how to do her job as long as the company’s enemies are silenced and pacified. Callister is ruthless in that pursuit and she does not flinch when ordering ambushes, acts of sabotage and preemptive strikes (and assassinations) against pirates, Black Marketeers, dark wizards and other ‘threats’ to Northern Gun. Sometimes that includes D-Bee rights activists, mages, adventurers and outspoken troublemakers. All dealt with as a necessary part of law enforcement and national security. Being “dealt with” can include being kicked out of the nation, arrest and imprisonment, arrest and coming to an understanding (e.g. threatened or tortured into submission or leaving town), to more permanent solutions like being gunned down in the act of a crime or terrorist act.

Andrea Callister, Chief of the LPO, Quick Stats: Alignment: Unprincipled. **Attributes:** I.Q. 18, M.E. 22, M.A. 20, P.S. 17, P.P. 19, P.E. 14, P.B. 15, Spd 9. **Experience:** 12th level Super-Spy. **Psionics:** I.S.P.: 90. Major Psychic. Ectoplasm (6+), Ectoplasmic Disguise (12), Impervious to Fire (4), Nightvision (4), Mind Block (4), Resist Fatigue (4), Telekinesis (varies) and Telekinetic Push (4).

Loss Prevention Officer O.C.C.

See the *O.C.C. section* for the *Loss Prevention Officer O.C.C.* and more information on the practices of the Loss Prevention Office, page 78.

NG Trade Council

The ultimate power within Northern Gun is the **Trade Council**, a group of eight executives from within the Northern Gun corporation and high-ranking administrators of the Republic of Ishpeming. The Trade Council has control over the corporation and the mechanisms of state. They are responsible not just for maintaining sales and market presence, but for seeing to Ishpeming’s defense and managing foreign affairs. And considering Northern Gun and its products’ influence over all of North America, the Trade Council are some of the most powerful figures on the continent, able to make or break entire kingdoms and city-states.

The Trade Council’s origins lie in the Board of Directors of Northern, Incorporated, the company that was the heart of the early Northern Gun. During the Dark Age, each board member had carved him or herself a kind of fiefdom out of Northern Gun land, people, property, resources and manufacturing capabilities. Before long, what had once been a handful of suit-wearing executives had evolved into the Dark Age equivalent of rail barons and merchant princes. Some of the positions were handed down through heredity, others were fought for in bitter turf wars or passed on using their own rites of succession. As Ishpeming and

the Northern Gun corporation expanded and became wealthy, each Council member’s personal power grew until they rivaled that of most kingdoms. Over the years, the roles the Council members played became defined and formalized. Today, they may be considered the department heads of the different divisions of the strange corporate-political entity that Ishpeming/Northern Gun has become.

Trade Council Positions

1. Chief Councilor/Ishpeming: The Ishpeming Councilor is in charge of the capital city, the populated surrounding region and its connecting port at *Marquette*. Whoever holds this position also serves as *Council Chairman* and *Chief Executive Officer* of the Northern Gun corporation. This post is limited in its scope, especially compared to the autocratic kings, dictators and overlords found elsewhere on Rifts Earth, but is still considered the highest office in the country/company, and a position of great responsibility. *The Loss Prevention Office* (LPO; Ishpeming Special Operatives) is under the direct control of the Trade Council, as dictated by the Chief Councilor, and many times in the past, they have conducted schemes and participated in conspiracies for the sole interest of whoever holds the Chief position.

2. Manufacturing and Labor: Without its factories and its workers, Northern Gun would be forced to desperately scrape by like so many other kingdoms. With them, however, it is a strong, independent manufacturing giant that, if the need ever arose, could direct all of its capacities towards the defense of the nation and corporation. Until that need manifests, though, the manufacturing arm of Northern Gun will continue to be used to swell the nation’s coffers and boost its economy. Part of that plan entails the crusade-like sales campaign to sell the weapons and the technology that keeps humanity in North America alive in the face of all opposition. The M & L Councilor is not only responsible for maintaining the output of these products, but for insuring that Northern Gun’s employees are kept happy, healthy and hard at work.

3. Escanaba: As Northern Gun’s most vital port and sales center, Escanaba is almost as important as the capital and the Northern Gun company’s manufacturing capabilities. More wealth enters the nation from Escanaba than at any other one point, and its sales alone are comparable to the combined total of all of Northern Gun’s other business.

The Escanaba Councilor is in charge of the upkeep of the city and the docks, as well as the collection of taxes, tolls, fees and other payments. Escanaba Councilors have historically skimmed a little off the top, becoming incredibly wealthy in the conduct of their office. With all the goods going out of Escanaba and all the customers and tradespeople coming in, it is difficult, if not impossible, to determine just how much they are taking for themselves.

4. Research and Development: One of the reasons the Northern Gun corporation was able to begin producing weapons and vehicles even in the Dark Age was the efforts of a network of salvagers and treasure hunters. This group excavated the universities at *Houghton* and *Marquette* as well as the ruins of factories and laboratories along the coasts of the Great Lakes and throughout the Midwest. These secrets were brought to Ishpeming and the still-standing HQ of *Northern Inc.* Over the years, the salvagers and the company’s scientists became one, first recovering and reproducing Golden Age technology and, later, designing their

own weapons and war machines. In its modern incarnation, the **Northern Gun Research and Development** branch is both actively developing products and ruthlessly stealing and reverse-engineering anything it can get its hands on. The R&D Councilor is charged with keeping the scientists busy, as well as organizing the theft, purchase, capture and other 'procurement' of desirable foreign technology. For this part of the job, the full services of the *Loss Prevention Office* are at the disposal of the Research and Development Councilor.

5. Shipping and Ports: Northern Gun/Ishpeming has long miles of coastline within its territory, a handful of major ports and countless small docks, off-loading points and accessible rivers. To attempt to monitor and oversee all the traffic coming into and going out of the country, a full Councilor position is dedicated to regulating ports and shipping. Land borders are not a concern for this position, though its authority overlaps a bit with the Ishpeming and Escanaba Councilors as the S&P Councilor has the ultimate decision-making authority regarding the country's ports and clearance practices.

6. The Military/IMCN: The highest-ranking military officer in the country is the Military Councilor. While Northern Gun does not maintain a traditional military, it is the Military Councilor's job to coordinate the many mercenary and privateer companies in its employ and see to an overall national defense policy. With the establishment of **Task Force X** to monitor the Xiticix threat, the Military Councilor's office has troops directly subservient to it for the first time, though they are under the command of their own general to avoid distracting the Military Councilor and to oversee the relationship between the Councilor and most mercenary commanders. Should the homeland ever be invaded or face an emergency that requires its full attention, the Military Councilor is expected to serve as Field Marshal and overall commander for the combined security, militia and mercenary forces of Northern Gun. The Military Councilor is in charge of training and equipping the *Loss Prevention Office* as well as *Task Force X*.

7. The Iron Fields/Western Border: One of Northern Gun's greatest assets is the wealth of iron deposits found along its western border and around *Marquette*. In the Dark Age, this area was relatively cut off from Ishpeming and grew into independent cities with their own system of government. In time, they joined forces with Northern Gun and let themselves be absorbed by the corporation. The region is still somewhat isolated, and the overseer/governor of the cities and mines of the Iron Fields has evolved into a full Councilor position. Not only is the Western Councilor responsible for developing and exploiting the Iron Fields, but also for the security of Ishpeming's entire western border. The mines in *Marquette* and elsewhere throughout the peninsula are also regulated by the Western Councilor's office, no matter where they are located.

8. Agriculture: Feeding the people of Ishpeming/Northern Gun is the responsibility of the Agricultural Councilor. The majority of the country's food supply comes from a few belts of productive farmland, most of which are located within the center of the nation. Importing and exporting food to and from *Manistique*, *Iron Heart*, *New Lazlo*, *Lazlo*, *Free Quebec* and *Chi-Town* is also under the purview of the Agricultural Councilor, though this part of the job is a more recent development. The farmland of Ishpeming is rich and fertile, even if the growing season is short,

and its farmers enjoy a level of safety and technology found at few places in the rest of the world.

Brett Morgan, Manufacturing & Labor Councilor

While the Chief Councilor is technically head of both the corporate and state elements of Ishpeming/Northern Gun, it is *Brett Morgan, the Manufacturing & Labor Councilor*, who plays the greatest role in the daily operations of the company itself. He is a former factory chief and supervisor who rose up within the company until he was given the top office in his department.

During his tenure, Morgan has introduced greater use of robots within Northern Gun factories. As the country's population growth has stabilized (few Tolkeen refugees made it through the Coalition lines and the Wisconsin wildlands), automation allows factories to make up for the growing cost of labor. Even though Northern Gun's people are considered to be its greatest resource, labor robots put to heavy use and some of the traditional assembly lines found throughout the nation are starting to look more like Golden Age factories or at least their CS equivalents. Still, the company makes sure there are plenty of jobs to keep its citizens employed and happy. With an unemployment rate of less than 2%, it is a job well done.

Brett Morgan, Quick Stats: Alignment: Scrupulous. **Attributes:** I.Q. 21, M.E. 20, M.A. 19, P.S. 15, P.P. 14, P.E. 12., P.B. 14, Spd 11. **Experience:** 12th level Operator.

Jacob Wyman, Chief Councilor of Northern Gun

Running the continent's largest company and the nation-state that supports it is not an easy job. It all falls squarely on the shoulders of Jacob Wyman, Chief Councilor of Northern Gun and head of the Trade Council. Wyman has held the top position for over a decade, and is responsible for Northern Gun's gradual shift towards an alliance with the Coalition States. He represents both the power and authority of the Trade Council and the overriding economic force that is the Northern Gun corporation.

Jacob Wyman grew up in *Marquette*, a city not far from Ishpeming itself. He has been a contract employee since age eighteen when he signed up to unload cargo ships at the docks, a tough job for anyone. Wyman refused to let the work get to him and soon enough, was coordinating the loading and unloading of entire vessels and shipping companies. He was transferred to corporate in Ishpeming soon after, and made a name for himself by turning *Escanaba* into a thriving city that Northern Gun can be proud of, instead of just a massive shipping hub and warehouse district. The efforts to make downtown Escanaba attractive and inviting are all initiatives put forth by Wyman's administration, and he has used his position at the top to see them through to completion. Considering Northern Gun is already the top brand name in America, he wants visitors and tourists to see the *Republic of Ishpeming* as a healthy and viable state with a growing population, not just a giant shopping mall for mercenaries and fledgling kingdoms. The Manufacturing & Labor Department is good enough at keeping up production levels that Wyman can focus most of his attention on the needs of the state, confident that Northern Gun will remain strong and competitive.

Jacob Wyman, Quick Stats. Alignment: Scrupulous. **Attributes:** I.Q. 19, M.E. 14, M.A. 23, P.S. 14, P.P. 11, P.E. 14, P.B. 13, Spd 12. **Experience:** 11th level Vagabond Merchant/City Planner specializing in logistics and political maneuvering.

Doctor Jon Kaminsky, Research & Development Councilor

Dr. Jonathan Kaminsky is the head of Research and Development for Northern Gun. Armed with a keen scientific mind seemingly from birth, Kaminsky has been a part of R&D since he was a teenager and has spent many thousands of hours testing his own designs and carefully taking apart alien and foreign technology to learn secrets he can incorporate into NG products. Kaminsky is behind many of Northern Gun's recent advances in hover technology, a field in which he specializes. He personally designed a handful of the company's hovercraft in addition to conducting his duties overseeing the entire research department.

Working on his own projects and watching his engineers and scientists create new mechanical wonders is fulfilling, but nothing satisfies Doctor Kaminsky's curiosity like examining new technology for the *Reverse-Engineering Department*. Cracking open the armored shell of a vehicle from another world or dimension, or disassembling an unknown weapon can reveal secrets years beyond the capacity of Northern Gun. And while the company cannot necessarily recreate every discovery, Kaminsky can certainly appreciate and get ideas from them. He is currently formulating a technological advancement plan for the next twenty years of Northern Gun technology, slowly upgrading the company to the CS pre-Campaign of Unity standards before incorporating newer, more difficult technologies recovered from new CS designs, Triax and alien equipment. Kaminsky is familiar with science and tech that would leave the average Operator speechless, and could easily hold his ground in a debate with ranking scientists on an advanced planet or Golden Age academic forum.

Jonathan Kaminsky, Research & Development Councilor, Quick Stats: Alignment: Unprincipled. **Attributes:** I.Q. 25, M.E. 19, M.A. 20, P.S. 18, P.P. 15, P.E. 18., P.B. 14, Spd 9. **Level of Experience:** 15th level Rogue Scientist.

The NGMI Credit System

A combined effort of Northern Gun and the Manistique Imperium, the *NGMI credits system* is, arguably, the second (or third) most reliable currency on the market. Depending on who you talk to, Coalition credits – better known as *Universal Credits* – are more stable because they are backed up by a much larger nation and accepted almost anywhere. Others say *Black Market credits* are more useful because they are widely accepted and not tracked by the Coalition. *NGMI credits*, however, can be exchanged for Universal Credits at many locations, and are also accepted by most Black Market outlets. Northern Gun is both a nation and the largest corporation in North America, and they use their dual status to bolster faith in their currency.

The circulation of NGMI credits keeps the Northern Gun brand name in people's minds and forces them to interact with Northern Gun in order to do their banking. Customers who use NGMI credits in their daily life spend a much larger portion of their income on Northern Gun products, and the Trade Council knows this. They are currently pushing NGMI credits as a "neutral" non-Coalition alternative for small kingdoms and city-states. The credits can be used to conduct business with Coalition interests, but are also accepted in places like *Lazlo*, *New Lazlo*, *Kingsdale*, *Whykin*, *Arzno*, the defunct *Tolkeen*, and even parts of the *Federation of Magic*, *Pecos Empire*, *Colorado Baronies* and elsewhere. The NGMI credit system gives Northern Gun a huge

advantage over smaller competitors and helps maintain the flow of new products to customers.

Northern Gun Retail Outlets

Northern Gun has two primary types of "stores" away from its hometown in Michigan. The first are **outlet shops**, most of which are small to medium-sized retail locations where Northern Gun products are available in a limited range and sold in small quantities, often to civilian customers. The second are **showrooms and warehouse centers**, large to massive stores where vehicles, giant robots and other "high-priced" items are available in good supply and large amounts of merchandise are displayed and stored. While any NG store can place special orders and have one or more items shipped to them, showrooms and warehouse centers are priority outlets that can usually get special orders within 1D4+3 days; half that time if within 800 miles (1,280 km) of Northern Gun. In addition, orders for large, high priced items or large quantities of items can be placed on behalf of a customer, and shipped to a showroom or warehouse center anywhere. Small stores and shops, especially those in remote areas and dangerous territories, may not be allowed to accept delivery straight from the factory in Michigan, and may have to have the item(s) shipped to the nearest NG warehouse center and pick it up themselves, then transport it to their outlet shop. This can add days or even weeks to the delivery time for the smaller shops. **Note:** All special orders require advance payment in full.

The average Northern Gun outlet shop is a candy store for mercenaries and adventurers, a combination gunshop and wilderness outfitter. Most people only think about the big robots and the flashy weapon systems, but the majority of the company's profits come from selling boots, outdoor clothing, canned food, freeze-dried rations, small tools, medical kits and equipment like flashlights and camp stoves. All are for sale at Northern Gun outlets, and the most common small arms and basic items are in good supply.

Outlets can be of almost any size, and most warehouse centers will have one or more outlet shops located in the same town as well as nearby communities to saturate the area with the Northern Gun brand and to be more accessible to everyday customers. Small outlets tend to specialize in 2-6 areas, such as adventuring/wilderness gear and weapons, or weapons, armor and power armor, or hovercycles, body armor, farm vehicles and robot horses and drones, or may offer only personal weapons, tools, E-Clips and batteries, and so on. Only 25% of outlet stores offer any giant robots or heavy combat vehicles, and even then are not likely to have more than 4-12 on site and available for immediate purchase. High-end products like giant robots, combat vehicles and a wide range of power armor, weapons, body armor and vehicles are usually limited to showrooms and warehouse centers. Though medium and large outlet stores are likely to have some power armor, hovercycles, small vehicles, weapons and armor actually on display, they will have only a few (1-4) of each in stock. For full-size combat robots, aircraft, ships and large vehicles, customers will be taken to a nearby warehouse center, airfield or shipping dock or will need to arrange for a special order and delivery of their purchase to a specific location. For this purpose, each "official" Northern Gun outlet shop will always have one or two Ordering Agents who can call in special requests by radio back to Ishpeming itself. Most Northern Gun outlet employees know

how to call in special orders, but only the Ordering Agent is given the verification codes necessary to clear them.

Showrooms and warehouse centers are 10-40 times larger than most outlet shops and have a bit more of a carnival-like atmosphere. Warehouse centers fulfill a different role than outlet stores. They are designed to sell the high-end, big ticket items – including literally “big” product such as giant robots, combat and exploration vehicles, commercial vehicles, heavy equipment and the full range of product lines such as hovercycles, body armor, power armor, weapons and so on. Such facilities are likely to have firing ranges and testing areas on site or nearby. Likewise, concealed warehouses or well fortified and defended corporate bunkers are likely to be located nextdoor or down the road. Showrooms and warehouse centers are always large, well-lit buildings with high ceilings to accommodate large products. Some are very slick and glitzy while others have more of a warehouse look and feel, but all are stuffed with crates and vehicles ready for a test-run or immediate sale. Customers are NEVER allowed to wander through warehouse centers unescorted, except in the actual showroom where display product is locked down and their power supplies often removed, making theft difficult and attempts impossible to go unnoticed. *Northern Gun employees* are expected to direct them to the experienced sales staff and assist to complete the purchases, help show off different product options, etc. When the customer has made his selection (most already know exactly what they are looking for and what they can afford), the item is prepped and made ready to drive or carry off the lot or packaged and loaded up for scheduled delivery to a suitable destination. Many mercenaries and experienced adventurers skip the outlet stores and go right to the showrooms and warehouse centers whenever they can.

As one might imagine, these large showrooms and warehouse centers are comparatively few and far between, whereas at least one or two NG outlet shops seem to be present in every flea-bitten town – at least the ones that cater to mercenaries and adventurers. In some cases, the general store is, in effect, an NG outlet store. Meanwhile, prosperous city-states and small kingdoms may have dozens of outlet shops and multiple warehouse centers like Merc-Town. Each warehouse center also serves as a supply hub for the smaller outlet stores who replenish their shelves from the warehouse’s stocks. Large deliveries are made to warehouse centers and showrooms, and then distributed by truck and hover-lifter to outlet stores for miles around. This is also where most “special orders” end up, requiring someone from the outlet shop to come and get it to its final destination. This simple network system has worked for Northern Gun to expand into new and old markets with alarming efficiency and ease, increasing in number and size as the community and market grows.

NG Returns Policy

Northern Gun has a return policy and warranty that nobody else can match. As a general rule, anything with a value of less than 100,000 credits can usually be exchanged for a new or rebuilt one, as long as the original does not appear to have been deliberately broken or clearly damaged in combat or left to rot in the elements. In short, any item that breaks under “normal” use and is less than 20 years old, NG will accept, repair, rebuild or replace for the customer. The 20 year cap is in place because Northern Gun products are known to last for decades when given a little

care and regular maintenance, so the company’s warranty is limited to two decades of use. Thus, a power drill, ion pistol or power pack that is non-functional will be fixed or swapped out for a replacement, no questions asked. **Note:** This return/replacement policy does NOT apply to the more expensive weapon systems, equipment and multi-million credit vehicles and robots, but certified NG garages perform maintenance, repairs and upgrades at a 20% discount on all high-end NG equipment, no questions asked.

With the hundreds of retail outlets and advanced repair facilities and subcontractors available to Northern Gun, fixing mechanical problems is much simpler for them than many of their clients and competitors. The product will be repaired, cleaned and repainted if necessary, and returned to the customer. Items exchanged for a new replacement are likewise repaired and repainted to be as good as new, and set back out on the store shelf for the next customer who comes along. This is another advantage of Northern Gun products having such a long shelf-life. Since products are so durable and seldom discontinued, a 20 year product design is still a viable sales item. Mercs and adventurers brag about their equipment and compare weapons and vehicles all the time, and keeping customers happy is a good way to maintain reputation and keep them coming back for more.

As long as a customer has a sales receipt and the item is unused/the packaging unopened or the goods are in like-new condition, NG retailers can issue a full refund credit voucher. However, the voucher can only be accepted and cashed out at NG showrooms, warehouse centers or Ishpeming itself. Likewise, any credit voucher for more than 45 million credits can only be redeemed at Ishpeming. Vouchers are only issued when there is clear proof of purchase and ownership. If anyone is caught trying to “return” stolen goods as a purchased product (and NG has a comprehensive list of serial numbers and identifying marks on all its goods), the merchandise is seized and the “thief” taken into custody and brought up on charges. Stealing NG goods, especially its big robots and war machines, has severe consequences. Like horse thieves of the Old West, they can be imprisoned or executed for their crimes. At the Coalition States, execution is the common penalty, and it may be exercised right on the spot at the discretion of Coalition soldiers and CS law enforcement when the perpetrator is a D-Bee, practitioner of magic, or member of a known rebel, terrorist or enemy group. The CS considers the theft and resale of stolen military-grade NG goods to be handling dangerous contraband and such criminals can be shot dead on sight.

Northern Gun Foreign Relations

Northern Gun conducts all diplomacy regarding the Republic of Ishpeming under its own Corporate Public Relations Department. Ambassadors from Ishpeming are also sales reps for Northern Gun, and discounts on products or the threat of a *Withdraw Order* are tools available to an NG diplomat. As a result, the foreign policy of Northern Gun is designed to enhance the corporation’s sales and put it in a position to access new markets. When the Northern Gun corporation can help secure the Republic of Ishpeming, they use their resources as a manufacturer and arms merchant to do so. When the national presence, territory and

sovereignty of Ishpeming can help further the profits of Northern Gun, it does.

Coalition States: Allies or Overlords?

Many people were surprised by the announcement of a non-aggression pact and economic cooperation agreement between Northern Gun and the Coalition States. After all, a huge percentage of the dissidents and independents that resist the Coalition are equipped with Northern Gun gear. Any deal with the CS could be a serious blow to Northern Gun sales and would certainly complicate the political picture of North America.

For many years, Northern Gun has conducted trade with the Coalition States. CS Iron Heart is close by, and actually is just across a river from the neighboring Manistique Imperium. Goods either leave Ishpeming and follow the northern half of the Imperium, or are shipped from Marquette directly to Iron Heart via Lake Superior. Lake Michigan also provides a relatively safe travel route, and ships regularly make the north-south run from Escanaba to the Coalition's Chi-Town ports near Old Chicago.

Still, trade is one thing, and an actual alliance is another. Northern Gun had a long-time policy of remaining politically blind and neutral. They opened their doors to *any* customer, and this is often still the case. To develop a deeper relationship with the Coalition States puts all that at risk, threatening to associate Northern Gun with human supremacists and alienate their D-Bee and magic practicing customers.

The NG Trade Council is willing to chance it, however, and sees many benefits to closer ties with the Coalition States. Should a serious threat like the Xiticix, the Splugorth or a new invader from the Rifts ever spill over into a general invasion of North America, Northern Gun is under no illusions as to who might come to their aid. Lazlo and New Lazlo, while well-intentioned, are too small, too weak militarily and would have their own share of problems to deal with should such a dire situation arise. The Federation of Magic has an actual disdain for technology, and many people within it would probably be happy if Northern Gun collapsed and see it as proof of the superiority of the mystic arts. Free Quebec is a strong, human supremacist power, but after their recent near-war with the CS, they have become even more aloof and reclusive and would be unlikely to risk significant resources to protect anyone but their own self-interest, certainly not Northern Gun or the Manistique Imperium. It is the Coalition States, and only the CS, that would stand ready to fight for Ishpeming if it should come under threat. The Coalition is already deploying soldiers to contain and neutralize the Xiticix Hivelands, the greatest known danger to Northern Gun, and already views Atlantis as a continent of enemies marked for elimination.

In return for a greater assurance of survival into the future, the NG Trade Council is willing to dance to the Coalition's tune, or at least make things appear so. The suspension of trade to the Coalition's enemies, for example, looks good on paper, but has much less of an effect on the real arms market than one might assume. Magic has long been officially outlawed within Ishpeming, so meeting the Coalition's demands in that regard has been easy. And while D-Bees are by no means hunted down like they are inside the CS, they have never been seen as equals next to humans and were relegated to the status of second-class citizens and outsiders long before a Coalition alliance was ever an option.

So far, the alliance with the CS has done nothing to hurt Northern Gun's sales or reputation. Only a tiny percentage accuse NG of selling out and serving as the pawns or lackey of the CS. Many others believe NG is actually playing the Coalition as a fool and using inside information to find better routes and ways to sell weapons and armor to independent kingdoms, city-states and adventurers.

The Manistique Imperium

For decades, the Manistique Imperium has been Ishpeming's "little brother." Located just east of Ishpeming and also protected by the geography of the Upper Peninsula, it has long been a manufacturer of industrial and agricultural equipment, as well as appliances, generators, civilian vehicles and other products. It has been known as the **Second Gun** for decades, and many still refer to it as such, some mockingly, some with an air of affection. Within the last twenty years, however, the Manistique Imperium has grown out of its reputation as a second-rate Northern Gun and subcontractor to NG.

The Imperium today is a nation on the move as well as a developing market force to be reckoned with. First, with various independent products and knock-offs of NG gear (much of it sold to the Black Market), then under the **Wellington Industries** brand, the Imperium has moved to claim a larger and larger share of the North American arms market. They now supply mercenary groups, adventurers and small kingdoms' militaries, just like Northern Gun.

Historically, the Imperium has made up for NG's huge advantage in size and reach by turning a blind eye to the Black Market. A vast percentage of the less flashy gear that the Black Market sells was originally manufactured in the Imperium. Northern Gun resents this arrangement a bit, but they have their own complex relationship with the Black Market. And due to their even closer ties to the Coalition and greater range of military products, the NG must be more careful to whom they sell their goods, especially weapons. Even with the Imperium making moves, they have barely made a dent in Northern Gun's sales, and the Imperium's "Big Brother" tolerates "Little Brother" flexing its muscles.

Despite the rivalry and modest resentment, the two neighbors of Northern Michigan have extremely close ties, both culturally and geographically. Their 50 mile (80 km) border is watched by only a few token forts and guard posts, more to direct traffic and maintain the Ishpeming-Manistique Highway than to stay alert for military attacks. This stretch of road is still the longest unprotected border between nations anywhere in North America, and possibly the entire world of Rifts Earth. Likewise, both nations have come to each other's assistance in times of need and disaster, and would do so again in a heartbeat. Both exchange information and work together to keep their borders safe from pirates, bandits, invaders, Xiticix and other threats.

The Black Market

A large percentage of Northern Gun's customers never enter a Northern Gun outlet or interact with an official retailer. They make their purchases on the Black Market, buying from the shadowy, illegal collection of criminal groups that sell to anyone who has the cash.

Northern Gun goods are a mainstay of the Black Market's sales. They are the most plentiful and easiest way to access weapons on the continent. Northern Gun has manufactured so many robots, vehicles and hovercraft that even their larger and more expensive items can be found at many Black Market outlets – in used and new condition. Since NG has been churning out and selling products for decades, older Northern Gun gear has filtered down through multiple buyers and sellers to end up on the Black Market.

The Black Market also gets many missiles, and other items that are difficult to manufacture on their own, from NG (and the Manistique Imperium). Since most of those things are high-profit products (mini-missiles are surprisingly cheap for NG and the Imperium to produce), Northern Gun does whatever it can to help supply the Black Market without making it look like they're selling to them. This is done by arranging for cargo to be seemingly "hijacked" and getting paid under the table or getting trade goods, raw materials, etc., via a legitimate front company or Black Market pawn.

The Black Market manufactures very little of what it sells. Instead, it purchases knock-offs from the Manistique Imperium and other companies, and acquires *stolen goods* for the vast majority of its remaining stock. Buying and selling contraband and stolen goods is their stock in trade. Northern Gun, by contrast, needs to manufacture items to survive. Ishpeming could never have grown so strong so fast without the billions of credits that have poured into the nation from customers outside of Northern Gun.

As a matter of practicality, Northern Gun and the Black Market have grown into long-term business partners, whether they like it or not. Even Northern Gun's best agents and mercenary network cannot match the Black Market for reach, and without the criminal organization, Northern Gun's profits would shrink noticeably (by an estimated 30%), even with all the products the Black Market actually steals and hijacks. The Black Market is responsible for 90% of every Northern Gun weapon, armor and combat item sold within the Coalition States, including the 'Burbs. Energy weapons are outlawed in CS population centers and the mass of squalid humanity known as the Coalition 'Burbs. Those caught trading in contraband are interrogated, imprisoned, and often put to death, but the Black Market defies the odds and makes a fortune doing so. Similar restrictions in Free Quebec and a few other kingdoms also make the Black Market the only distributor of Northern Gun weapons, even in areas with official NG outlets that sell civilian goods.

Agents within the Black Market. As complicated as Northern Gun's arrangements with the Black Market are, both organizations are actively involved in working together and at the same time, interfering with each other's business. The Black Market definitely has people on its payroll who officially work for Northern Gun, but, more surprising, NG hires Freelance Spies and deploys LPO (Loss Prevention Officers) to infiltrate Black Market groups and find out what is really happening behind closed doors.

Northern Gun is happy to sell products off-the-record to agents of the Black Market, or "arrange" for theft and hijackings and get paid under the table. But the Black Market also buys goods from bandits, pirates and adventurers they know have been stolen from Northern Gun and even tip such crooks off about NG trade routes and scheduled deliveries. If too much of the latter is going on, a handful of Black Market smugglers and thieving "associates" will have to be taken down (arrested and imprisoned or killed

outright, especially if they are freelancers and not standing members of the Black Market organization) in order to reestablish the proper balance. This way, Northern Gun can rely on the Black Market to spread its goods to customers it cannot sell to openly, all the while maintaining plausible deniability and a certain level of respect for the legitimate operations of the company. When it comes to protecting its profits and its market share, Northern Gun can be just as ruthless and vindictive as any mobster.

Black Market Storage Services. The Black Market also makes good money simply storing contraband and illegal goods for travelers who need to go into Ishpeming to shop. Carrying around Naruni or Techno-Wizard devices can attract undue attention, leading to the equipment being confiscated and possible arrest or fines for the owner, or even complications with CS soldiers and spies in town. The Black Market has no such restrictions, and those who know where and how to look for them can find market storehouses near the outskirts of most Northern Gun cities. The Black Market will store virtually any item for a few hundred credits per week, or a vehicle, robot or suit of power armor for 1,000-2,000 credits a week. The Black Market operates in secret and is not under observation by the CS, so most of these storage safe houses are quite safe and secure. The Ishpeming authorities NEVER go looking for these facilities and turn a blind eye to D-Bees and practitioners of magic who keep a low profile. Should the LPO or mercenary law enforcement actually raid a Black Market storehouse, it is usually for show or because the facility is being used to store goods stolen from NG against its will or involved in some other nefarious activity. There is no compensation or insurance for lost property from a storage safe-house, but those types of raids are quite rare. The Black Market knows how far it can push things and seldom oversteps its bounds in Michigan.

It doesn't happen as often, but the Black Market sometimes provides storage services for Northern Gun, itself. This can happen when the company is transporting more goods than it can accommodate at its own warehouses, is trafficking in contraband, and when NG is operating far away from its home base in Michigan or is trying to avoid complications with the CS. Northern Gun NEVER stores, transports or sells Black Market products.

Naruni Enterprises

Nadine stole a quick look around as the lights dimmed. Twenty-three other potential Northern Gun Sales Reps had been squeezed into the small classroom. Each one focused on the screen ahead, not daring to show distraction or familiarity.

Dr. Jonathan Kaminsky appeared on the viewscreen. He was head of Research and Development for the entire Northern Gun company; making the man both a political powerhouse and extremely well versed in technology.

"Good afternoon, Northern Gun employees. I am here today to talk to you about the dangers of Naruni technology."

Kaminsky took a large, bulky, alien energy weapon from a table behind him and held it up.

"Now, some of you may have seen these already, probably being confiscated by Loss Prevention Officers. This is a Naruni plasma cartridge rifle. It is a powerful, short-range weapon and should not be underestimated. It is, however, manufactured using slave labor – and even more despicable methods, on dozens of different alien worlds. The Naruni have a different outlook on life

than we do, and have no qualms about destroying entire populations in order to sell their products. Our intelligence efforts indicate that this is their plan for Earth: to enslave people in remote areas and force them into slave labor in their factories, and to create dissension and war across the continent to drum up sales. They will sell to any group, including Xiticix, Horune Pirates, Brodkil, vampires, dimensional raiders, demons, and other monsters. For these reasons, Naruni weapons and technology are a danger to us all and not allowed within the Republic of Ishpeming. Those who insist on trafficking in these goods must be identified, tracked down, arrested and prosecuted. We have the Coalition States' help in that regard, so do not hesitate to call upon them.

"This not about eliminating a dangerous market rival. This is about a real and present danger from an alien invader seeking to undermine our way of life. And the danger doesn't end there."

Kaminsky pulled on a pair of surgical gloves and picked up one of the gun's shells with a pair of plastic tweezers.

"What I have here is a Naruni plasma cartridge. There is a lot of heat and power stored inside such a small container. Too much, it seems. Our science and medical teams have been able to disassemble Naruni ammunition and measure the output of dangerous radiation that they produce. Each one of these shells emits as much radiation as a leaky nuclear power core. Prolonged exposure can lead to hair and skin loss and cancer, as well as mental and reproductive side effects. Handling broken or cracked ammunition can cause severe blisters, open sores and cause permanent respiratory damage in a matter of 48 hours.

"For these reasons, we must ask that you stay away from any and all Naruni products and immediately report those you find to the Loss Prevention Office. Let customers know the dangers of Naruni technology, and remind them how safe and reliable Northern Gun products are. I have been authorized to give our sales force permission to offer these people, ignorant to the dangers of ALL Naruni technology, a Northern Gun product replacement at a hefty 50% discount – something from our line of plasma ejectors or particle beam weapons, perhaps. If they agree, make the sale and take the dangerous Naruni weapon to the nearest NG police officer or better yet, the LPO. If the individual refuses to exchange the weapon, do not press the matter, but try to get information about who the individual is, where he is staying, where he acquired the item, and turn the info immediately over to the LPO, NG law enforcement, CS military or law enforcement, or a senior Northern Gun sales agent. Do not hand it over to the local authorities.

"At Northern Gun, we care about our employees like our own family, and that same feeling extends to our customers. Do your part to keep them safe – and keep Naruni gear away from Earth. Thank you."

Northern Gun finds competition from other-dimensional rivals extremely unwelcome and unfair. Competitors like Wellington and Wilk's are one thing, but **Naruni Enterprises** represent a technology base decades ahead of Northern Gun and even Tri-ax. The D-Bees' reputation for being ruthless and underhanded precedes them, and the Trade Council is happy to do anything they can to undermine Naruni operations, including exaggeration like the presentation above. It is to this end that they cooperated with the Coalition States to eliminate the alien arms merchants, a move that dealt a decisive blow to the Naruni's plans for expansion

into the North American market. Since then, Northern Gun has kept up the pressure, dispatching spies, mercenary hit squads and Loss Prevention Officers to track down the new wave of Naruni imports. When discovered, they either take action themselves or report to the Coalition States. The CS is zealous in their efforts to eradicate Naruni Enterprises and their alien technology from the face of the planet, always responding quickly and with deadly force.

Trading in Naruni Equipment and Personnel. For former Naruni customers who have realized the error of their ways, Northern Gun offers redemption in the form of cash vouchers and percentage discounts for those who trade in Naruni products. All working Naruni products may be traded in for half the value of an NG equivalent item and get the individual a Northern Gun voucher that can be spent at any NG retail outlet or warehouse center. Or the individual can turn over the Naruni gear and get equivalent NG goods at an impressive 50% discount. Such trades must be done with care, however. If the trader is suspected of being in cahoots with Naruni Enterprises or a seller of Naruni goods, that individual(s) is likely to be arrested and face imprisonment or execution. If turned over to the CS to investigate, execution is all but a certainty. This cunning campaign has enabled Northern Gun to successfully paint Naruni as monsters, taking their Naruni competitor's products off the street, and replacing them with their own. Mercs who are tired of worrying about the Coalition or the Loss Prevention Office coming after them for possessing Naruni equipment may be happy to get rid of equipment that has become a liability, no matter how superior it is. Naruni weapons and vehicles are certainly outlawed in the Ishpeming Military Contract Network, and Loss Prevention Officers keep an eye out for them at every Northern Gun sales outlet.

There is a catch when turning in Naruni products, however. The Loss Prevention Office monitors and records anyone and everyone who receives a voucher or discount in return for Naruni gear. For someone who exchanges a handheld weapon or a few cartridges of ammo, there is little to fear. Keep coming back with Naruni and/or other alien guns and equipment, however, and the LPO will take note, and most likely share that information with the Coalition Army. Show up with an expensive vehicle or drone and one is automatically on the list, watched with concealed suspicion and sometimes secretly arrested or detained until more information can be extracted. One way or another, whoever is at the end of that trail is about to have a very unfriendly run-in with mercs, LPOs or Coalition Special Forces.

Relations with Other Foreign Powers and Corporations

Lazlo: Lazlo is a consistent customer of Northern Gun's wares. While they are a city of magic, and many residents use Techno-Wizardry and other methods in place of technology, Lazlo also has a sizable non-magic population. Many of these people feel more comfortable using normal devices, tools and weapons, because they are more familiar, less expensive, and due to a personal lack of magic energy. The government of Lazlo is quite permissive regarding the presence of Northern Gun products, who maintain several "unofficial" outlets in the city in addition to numerous Black Market run stores offering NG goods. Lazlo and all communities of magic practitioners are of grave concern to the

Coalition States and regarded as a serious threat if not an outright Enemy of Humanity.

New Lazlo: Just like its parent city, New Lazlo is located close enough to Northern Gun that it is by default, a major client. Sited within Southeastern Michigan (on the bones of pre-Rifts Ann Arbor), New Lazlo conducts most of its trade with Northern Gun from its port south of Detroit. While it does provide relatively easy water access, ships must make the dangerous journey down the St. Clair and Detroit rivers. The St. Clair River is a relatively peaceful trip, but the Detroit River has the haunted ruins of Detroit on one side and Windsor on the other, both of which are notorious hot-spots for Rifts and demonic activity. Ships' crews tend to "button up" and seal themselves off in the best defended portions of the ship during this leg of the journey. Means of magical transport and the use of ley lines are also used, but such magic must be performed outside the knowledge of Ishpeming and most Northern Michigan cities and towns to avoid issues with the CS.

Titan Robotics: The mysterious robot manufacturer has been a mystery to Northern Gun for many years. It is only recently, however, as Titan's sales numbers and product line have expanded, that they have become a real cause for concern. What is most frustrating is that NG's spies have produced almost no information on the secretive corporation, even after years of scrutiny. Attempts to infiltrate an undercover agent into the company have also been fruitless. Titan produces some of the best open-market robots and power armor in America, and Northern Gun would very much like to know where and how they do it, as there is no way the Titan factories at New Cedarville can manufacture all the robots Titan sells. There has to be a secret manufacturing center somewhere, but where? And why the secrecy? The Loss Prevention Office is determined to find out. So far, NG has kept its concerns and suspicions from their CS allies.

Wellington Industries: Wellington is quickly becoming the signature brand name of the Manistique Imperium. Northern Gun has been preparing for this eventuality for a long time, watching as the Imperium's market share increased every year. In response, they have reacted to Wellington's specialty in explosives and ballistic weapons by scaling back new research into similar projects and by making sure that Northern Gun ammunition is compatible with all Wellington products. They have also been quietly producing knock-offs of Wellington's grenade and mini-missile launchers and selling them at a 10-25% discount to the Black Market and to unaffiliated vendors.

Wilk's Laser Technologies: While Wilk's does manufacture a huge volume of laser tools and weapons, and an almost immeasurable amount of circuits and electronic parts, their efforts have not yet branched out into other areas such as robotics, vehicles, armor or other weapon systems. There was a former Wilk's executive on the NG Trade Council for several years, and the relationship between the two companies is tense, at best.

Northern Gun has quietly and recently convinced the Coalition to issue a blanket-ban on all Wilk's weapons within Coalition territory, citing their ability to slip past metal detectors. However, Wilk's remains popular in and outside of CS held areas. The corporate leaders at Wilk's would be more outraged, but the highly-publicized Coalition ban has given their products an illicit appeal that has actually increased their sales, especially in the Black Market and to CS resistance groups. Wilk's is unaware

that Northern Gun is behind this ban, and doesn't really care one way or the other. **Note:** NG attempts to reverse-engineer every new Wilk's release, a practice that has taught their techs quite a few things about making high-quality laser weapons, but has still left them unable to accurately replicate Wilk's lasers.

Iron Heart Armaments: Northern Gun watched with intense interest as the upstart weapons manufacturer known as Iron Heart Armaments was established by Coalition rogues only to be subsequently re-conquered and absorbed back into the CS. The large ships and aircraft they produced were viewed as a legitimate threat to the Coalition States, a lesson the Trade Council has taken to heart. Long-range bombers, missile ships, nuclear weapons and similar development projects are all prohibited by the Trade Council for fear of pushing the Coalition into reacting with a military response. The two Sea King missile cruisers that Ishpeming acquired from IHA, the *NGS Superior* and *NGS Michigan*, are both used strictly for coastal defense purposes and are well known to the Coalition Navy. *Michigan* even participated in a joint naval exercise with CS forces in the summer of 108 P.A., the first time that the two nations' militaries have officially worked together.

Golden Age Weaponsmiths: Golden Age Weaponsmiths are known for their advanced, Mega-Damage conversions of pre-Rifts vehicles and weapon systems. Overall, however, their gear is usually slightly below Northern Gun's in tech level and arguably patchwork. The Trade Council sees GAW as a specialist working in a market that is just different enough that NG doesn't view them as a direct competitor, but more of an ambitious subcontractor.

Triax Industries: The European and North American markets see very little overlap, and Northern Gun is unconcerned with Triax and its virtual monopoly over the arms trade in Europe. For while Triax products do make it to North America, their agreement with the Coalition States has drastically cut down on the overall amount. Northern Gun's fears that the continent would be swamped with German exports have so far turned out to be unfounded. For now, Northern Gun is happy to purchase Triax technology and attempt to reverse-engineer it, all while trying to formulate a plan to get their wares into the European market.

The Xiticix: The growing Xiticix infestation in Canada and northern Minnesota has alarmed the Trade Council into finally organizing a response. In addition to the creation of **Task Force X**, Ishpeming's western field army, the research and development labs have also begun to design and test new anti-Xiticix weapon systems, including robots such as the *Bison*, *Bruiser* and *Buffalo*. The Council believes that containing the Xiticix threat will be a 10-20 year operation and may represent a significant profit-making opportunity (and possible threat to all life on Earth). With this in mind, they will take a back seat in any offensive action against the Xiticix, offering discounted weapons and equipment but putting very few of their own troops or resources at risk. Should all-out war with the Xiticix become a reality, Northern Gun will commit Task Force X to the battle and follow up by hiring or re-deploying several large mercenary units along the eastern border of the Hivelands.

The Republic of Ishpeming

Republic of Ishpeming Total Population: 1,125,000-1,500,000.

Ishpeming – 697,000

Escanaba – 260,000

Menominee – 50,000

Ontonagon – 15,000

Houghton – 10,000

Iron Mountain – 5,000

Iron Bay – 3,000

Ironwood – 2,500

Iron River – 1,500

Notes:

Population Distinctions. For most purposes, the populations of Marquette, Palmer, Negaunee, Gwinn, Trenary and Fort Sawyer are counted as within the Ishpeming urban area. Each of the cities is linked by continuous roads and suburbs and it is difficult to tell where one begins and the other ends. There is also a huge amount of traffic in the form of daily commutes between Ishpeming and Marquette. Some people even make the commute all the way to Escanaba, made possible by the IM Highway.

In addition, another 100,000 people and D-Bees live in small communities, temporary camps and unlicensed settlements throughout the country.

Outsiders. Approximately 30,000-40,000 tourists, visitors, customers and transients are also present at the nation's ports, border cities and Ishpeming itself at any given time. More than 90% of the nation's visitors will be found in three places: Ishpeming, Escanaba and Menominee, in that order of popularity.

The literacy rate is high throughout the Ishpeming Republic (and Manistique Imperium) at 63%, at least among its permanent *residents*. Illiteracy and lack of book learning is really only found among some of the factory workers and labor force, farmers, homesteaders, pirates, bandits, wilderness people and the poor. Of course, illiteracy is prevalent among outsiders and visitors; less than 25% can read and write.

Northern Gun, aka the Republic of Ishpeming

A seemingly endless expanse of pine trees and rocky coastlines, the **Republic of Ishpeming** was saved from the full ravages of the Great Cataclysm and the Coming of the Rifts thanks to its isolation and a bit of luck. When the modern world collapsed, the cold, deep, Great Lakes provided natural obstacles to anyone or anything that wished to reach Ishpeming. Its only land border, where the peninsula meets the old American state of Wisconsin, is a remote wilderness, lightly traveled and scarcely populated.

Inside the country is an atmosphere of peace and prosperity virtually unknown throughout the rest of Rifts Earth. Ishpeming's people may not be the wealthiest, and are certainly not the most worldly, but they are spared the dangers of the wilderness, the oppression of the Coalition States and the uncertainties of magic.

They live much as their ancestors did, simple lives unfettered by politics or war. The weapons and war machines the Northern Gun corporation manufactures go to conflicts far away (or at least on the other side of the lakes), leaving the Republic of Ishpeming alone and at peace.

Cities of the Republic are an interesting collection of the high-tech and familiar low-tech. Simple wood and stone cottages and houses are the norm, yet across the street or down the road may be a high-tech bunker, warehouse or factory made of M.D.C. materials. The most quaint dwellings are log cabins and many farms resemble something out of the old pioneer days – only the giant robot standing guard or modern farm vehicles and equipment indicate otherwise. Hovercycles and giant robots compete for room on the streets with teams of horses, oxen and mules, along with everything from primitive automobiles to pushcarts.

The general technology level is equal to 20th Century America, even in the most primitive parts of the Upper Peninsula. Most homes have running water, air conditioning, a heating system, and are wired with electricity – personal generators, windmills and solar panels are all common sources of energy. In towns and small communities, hovercycles, jeeps and ATVs, along with horses and labor drones carrying parcels back and forth, are as typical as seeing excited groups of visitors and tourists. In the biggest cities like Ishpeming and Escanaba, there are more hovercraft than wheeled vehicles and almost all the high-tech luxuries of a Coalition or German city are available, though in shorter supply. The atmosphere is very different in these cities, too. Escanaba and Ishpeming are a giant, ongoing party compared to many of the work-a-day frontier towns and industrial districts.

The people who inhabit Ishpeming also differ from the big cities to the small towns. Ishpeming and Escanaba are full of tourists, businesspeople, mercenaries, adventurers, bandits, diplomats, soldiers and outsiders come to buy and trade goods or spend their spoils on entertainment, hot meals and a soft bed. D-Bees, Psi-Stalkers, mages, Cyber-Knights and other “exotic” people are much more likely to be found at these thriving metropolises and trade centers than anywhere else. The suburban communities are typically full of Northern Gun employees, subcontractors, small business owners, entrepreneurs, specialists and Ishpeming's middle-class.

The cities and towns further away from the trade centers are lower middle-class factory workers and laborers, while the small towns are made up of farmers, ranchers, fishermen, laborers, shopkeepers, outdoorsmen, loggers, and hunters. Unlike big-city folk, they are well removed from the politics of the world at large and content to live peaceful lives away from war and conflict. While they may hear about the broad strokes of major events like the war in Tolkeen, the near-miss showdown between the Coalition and Free Quebec, trouble with the Xiticix and the brewing Minion War, they are thin on details and most don't care. The Federation of Magic and the tall tales of the Vampire Kingdoms of Mexico might as well be half a world away. And that's how most locals like it. By contrast, the big cities are constantly abuzz with the latest news, rumors and speculations about everything, everywhere on the continent. This is due to the vast number of mercenaries, adventurers and visitors who pass through Northern Gun, as well as the many mercs and freelancers hired by NG.

The Republic of Ishpeming is also home to an entire social class of fishermen, sailors, merchant-sailors, ship captains, privateers and ferrymen, not to mention pirates and freebooters. They



are the unchallenged experts on the Great Lakes, familiar with every bay, island and adjoining river. Even the mighty Coalition has a habit of hiring ship pilots and navigators from amongst the sailors of Ishpeming, relying on them to safely maneuver its massive warships through unfamiliar stretches of the lakes and rivers and up into Canada.

Crime is minimal throughout the Republic, even in the big cities. The Northern Gun corporation runs a tight ship and has a firm grip on maintaining law and order. A stable, centuries old government and the overall level of prosperity and contentment in this working man's industrial nation helps immensely. As does the strong presence of so many mercenaries and police who work for the company to keep Ishpeming safe. Even the Black Market has few outlets and little influence inside Ishpeming and its neighbors. However, though city streets and communities are safe and peaceful (many people leave their doors unlocked), banditry beyond its borders as well as piracy across the Great Lakes are rampant.

Welcome, you are entering Ishpeming, the Home of Northern Gun

I remember the very first time I saw what has since become known as **Northern Gun**. I was 11 or 12, and I had convinced my mother to let me accompany my father and some of the other townsmen on a bi-annual supply run to the Kingdom of Ishpeming. The only place that would have a bigger impact on my adolescent mind would be my first visit to the Great Library of Chi-Town.

For most of our trip from Wisconsin to Ishpeming, we had traveled through wilderness. We had traveled what seemed like an endless expanse of forest, broken only by the occasional homestead, woodland cabin, farm or tiny trading post. Then, the trees suddenly vanished. Cut down to create a wide, flat expanse of grass and wildflowers that stretched several miles ahead of us. Even from there, in the distance, I could see the shadow of a city outlined beyond the emptiness. My heart skipped and I must have looked startled or confused, because I realized my father was speaking to me and explaining why the trees were cut down.

It's for defense and security, he explained. If Northern Gun left the trees, the forest would provide a place for bandits, hijackers and monsters to hide and take cover. Cutting down the trees created a wide open expanse around the industrial city. This enabled Northern Gun defenders to see a band of raiders or an invading army coming for miles. Most weapons cannot fire that distance, either, so the city defenders could respond to an incoming attack before the raiders got within shooting range. I remember feeling sad that they had to cut the forest down because of bad people, but it made sense, and my thoughts were quickly occupied with other sights and sounds.

Up ahead, the wide road was getting congested. There were many other trucks and vehicles, but also animal-drawn carts and travelers on foot; some of them pulling carts. The slow animal-drawn carts and people on horseback traveled off to the side of the road, to let the faster, larger vehicles drive down the main highway. As a child, I was excited to see a range of different riding animals like Fury Beetles and Rhino-Buffalo, as well as horses and mules. I remember marveling at a pair of dinosaurs ridden by Simvan. And there were Psi-Stalkers and D-Bees present too, and what I was certain were a small group of Ley Line Walkers in their traditional robes and headgear.

Even the highway itself was a marvel to me. After traveling hundreds of miles of dirt roads and open ground, a smooth, concrete road wider than 8 or 10 houses placed side by side left me dumbstruck. I remember thinking it was like a giant red carpet welcoming us to Northern Gun. Off to the side of the road was an array of pitched camps with curls of smoke spiraling up into the sky from campfires and portable stoves. All manner of vehicles and carts were parked at these campsites and in the fields off in the distance. I started to count them, but we were traveling too quickly for me to take account of them all. There were hundreds and hundreds of them.

Back when I was a child, the designated parking area was covered in loose gravel. That was where you parked, two miles (3.2 km) away from the city gates. Giant robots and tank-like vehicles stood guard over the parking area. From there, you had to walk the rest of the way. But with Northern Gun clear in the distance, our feet moved as if they had wings, and we were there to see new wonders in what seemed like no time.

Before we left our truck to embark down the beckoning road, I remember looking up at my father's smiling face as he took my hand in his. I was surprised to realize he was as excited as I, this being only his second visit to Northern Gun. My eyes trailed from papa's face and up to the gigantic, neon sign over the road. It read, "**Welcome, you are entering Ishpeming, Home of Northern Gun.**" For those who could not read, which I imagine was most of the visitors, an audio recorded welcome blared from speakers on the sign.

I couldn't help but to feel giddy and thought to myself, this must be how Dorothy felt as she walked down the Yellow Brick Road toward the Wonderful Emerald City of Oz.

*— From the writings of Erin Tarn, Circa 101 P.A.
in her book, Traversing our Modern World*

Many first time visitors, young and old alike, have a similar experience to the young Erin Tarn's. If anything, the city of Northern Gun, gem of the Ishpeming Republic, is even more of a brightly colored wonderland than it was back then. Its wide streets filled with crowds of people, vehicles, robots, lights, and the sounds of music, announcers, and pure adrenaline.

Years ago, the gravel covered parking lot was expanded and replaced by a massive, paved parking lot. (Think Disneyland.) Several large, bunker-like buildings are way-stations where visitors can stow the weapons and gear that are not allowed in the city. Audio instructions are announced at intervals, and there are hundreds of kiosks with headphones for more detailed information and instructions inside the buildings.

Swords, side arms, and body armor are allowed in the city, though discouraged, but to keep the people and property of Ishpeming safe, heavier weapons such as rifles, power armor, and combat vehicles are NOT allowed into the city, and must be left behind. To protect visitors' belongings, there are **Secure Storage Bunkers** located 2-3 miles (3.2 to 4.8 km) away from the city. Each building has thousands of indoor lockers of all sizes as well as small to large storage cages and bays like those you'd expect at a rental storage place. Each Secure Storage building is a simple M.D.C. bunker with several floors: four levels underground and six floors high. They provide a relatively safe place (break-ins are rare, but they do happen) to stow weapons, armor and valuables. ALL rifles, heavy weapons, explosives, power armor, robots, combat vehicles, magic items, Techno-Wizard items, and contraband must be left outside the city.

The parking area is brightly lit at night, monitored with cameras and patrolled by NG guards. However, visitors can pay for an armed guard to watch their vehicle around the clock, provided they can afford it; 144 credits per 12 hour shift, per guard. Most are honest, first to third level Mercenary Soldiers, Vagabonds, or other Men-at-Arms O.C.C.s who have been checked out, vetted, and cleared by the Northern Gun Corporation for the purpose of private guard. If serious trouble arises, the police (or LPO) are called in for support.

City Rats who, of course, have not been vetted or authorized by the company are often willing to guard vehicles for 50-70 credits per 12 hours, per "unofficial" City Rat guard (level 1-4 City Rats). If they run into trouble they can't handle, they cause a ruckus and shout for help that should attract the NG patrol and guards and scare away thieves. Most City Rats who make a living or supplement their living doing this work are honest and do a good job, but none will risk their own life to protect the vehicle (or a campsite; they offer the same service to watch over campsites). HOWEVER, any City Rat guard who is willing to take less than 50 credits is either an untested and unreliable amateur, or is just going to run off after an hour (especially if paid up-front), or works with a gang of thieves or is one himself.

Bus-like shuttles pick up visitors and take them to the nearest **Hovertrain terminal** at no cost, or people can walk. Hovercycles and light commercial vehicles (i.e. non-combat vehicles) are allowed into the city, but the traffic through the city gates is long and slow moving. The train takes visitors to the main terminal in the city or to other authorized destinations. The Ishpeming Republic is very open, and visitors can travel anywhere within its borders and beyond, with few limitations. However, the two main places of interest are the City of Ishpeming/Northern Gun and the City of Escanaba. Few visitors, even merchants and mercs, ever

go anywhere else. Obviously, there is little of interest in the quiet, suburban neighborhoods and factory zones. It is the market areas and city attractions where stores, hotels and places of entertainment are located.

The Safe Zone, as Northern Gun likes to call it, is the treeless area Erin Tarn speaks of. Only today, it is expanded, much of it paved and used for parking, and there are Secure Storage Bunkers as well as defensive bunkers with big guns to discourage raids and invasion. The Safe Zone goes back, away from the city, for a couple of miles. It is devoid of trees, and has been so trampled upon and ridden over by vehicles, that half of it is dirt that turns to mud when it rains. Travelers are still allowed to pitch camp out in the open in this zone, but such camps are temporary – meaning a few days to a couple of weeks, maximum. While Northern Gun authorities try to keep the peace in the Safe Zone, and they certainly chase off anyone deemed a potential threat to city security – including platoons and companies of mercenaries and other well-armed groups – campers are pretty much on their own. That means they should NEVER leave their camp unattended and must be prepared to defend it and their belongings by any means necessary. Whether other campers come to another camp's defense is a matter of luck and the alignment of their neighbors.

Between the Safe Zone and the city gates, there is a completely empty, dirt and gravel covered **Security Zone**. It is two miles (3.2 km) of dirt lightly covered in gravel with small patches of grass and weeds. Nobody is allowed to park or camp in the Security Zone and it is always empty. Travelers who venture off the road and into the Security Zone will be met by security and escorted back to the road. This is, in effect, a defensive kill zone in which the city defenders can see and fire upon any hostile attackers coming toward the city. Travelers beware. Anyone who looks suspicious, resists escort, or appears to be rushing toward the city with unknown intentions, may be subdued, arrested and interrogated or gunned down where they stand.

Northern Gun does not have 'Burbs like Chi-Town and other CS cities, but it does have visitors who camp, for short periods, in the Safe Zone and neighboring wilderness. Squatters, homeless people and supposed visitors who overstay their visit are chased away from the city by NG mercenaries or the police.

Giant defensive bunkers with cannons the size of skyscrapers are placed at strategic locations at the edge of the Security Zone and around the city. They, alone, are a sight to behold. Nobody knows the incredible level of damage they must inflict, because no invader has ever tested Northern Gun's defenses to the degree that these weapons had to be unleashed. This has led some to question whether or not they are a masquerade. A sham. High-tech scarecrows designed to intimidate by their mere presence, but not real. On the other hand, they might be exactly what they look like. As you can imagine, rumors abound about the massive defensive towers and their giant cannons. It is a common belief that one blast can atomize a tank, giant robot or an entire company of soldiers.



The City of Ishpeming

Home to the Northern Gun Corporation

Ishpeming, better known as simply “Northern Gun,” is the largest independent city in Michigan and the hub of technology and culture. It is the home and headquarters of the Northern Gun corporation and has enjoyed the benefits of the company's high-tech weapons and manufacturing for longer than any other community on the American continent. Since the Two Hundred Years Dark Age it has prospered, safe in Northern Michigan, far from the continent's most active magic zones and protected by the icy Great Lakes.

While Ishpeming's less desirable neighborhoods are covered in soot from the factories that ring the city, it is gradually growing out of the giant, industrialized camp that it once was. Ramshackle tenements and collections of improvised shelters have been cleared away to make room for modern apartment buildings and modest rental properties. More schools and hospitals have gone up in the last few generations, and Ishpeming's population is composed of families and corporate employees who can trace their lineage back to before the Great Cataclysm, while embracing new, young families who have come to the Republic of Ishpeming to find work and build a new life. Most of the tourists who visit the city come for the large markets downtown or the spectacle of the Robodome, and avoid the densely populated suburban neighborhoods and farm communities.

Northern Gun's fabled Downtown City Center is a sprawling collection of showrooms, tall buildings, hotels, stores, shops, entertainment and attractions that has many of the features and qualities of pre-Rifts destination cities such as Manhattan, Chicago, Toronto, Las Vegas and Los Angeles. There are hotels and restaurants, bars, dance clubs and a seemingly endless array of stores, shops and sights to see. The largest Northern Gun showrooms and warehouse centers – all lit up with lights and neon that rival a rainbow in color and outshine it in pure intensity – are among the main attractions of downtown. Best of all, all NG retail stores throughout the Republic are heavily stocked and EVERYTHING Northern Gun has to offer can be found in abundance. This makes Northern Gun a wonderland for men of arms and adventurers of every stripe.

The infamous Robodome sports arena, lit up by spotlights and holograms, is packed to capacity every night. Downtown is said to never sleep, and nearby, on the edge of the NG Corporate District, Northern Gun Headquarters looks down over the city. A true skyscraper like the kind normally only found in the Coalition States, it impresses a sense of power and resilience upon all those who see it, even from a distance.

City Highlights

Northern Gun Corporate District

An entire section of downtown Ishpeming and the adjacent industrial districts are all devoted purely to the operations of the Northern Gun. The corporate HQ is found within the center of the Corporate District, and with the exception of a few outlying buildings that are open to the public, there are no foreigners or non-contract employees allowed in the area.

For the workers, engineers and managers who work within it, the Corporate District is a beehive of activity. From the upper floors of the towering corporate HQ, one can behold the armies of trucks, workers, labor robots, trains and small aircraft that make up the commercial heart of the Northern Gun. The Corporate District blends into a factory belt adjacent to Ishpeming itself, far enough from the actual city that only a moderate amount of soot falls on homes and businesses.



NG Headquarters, Ishpeming

Located in the Corporate District near Downtown, the tallest building in all of Ishpeming is the impressive corporate headquarters for the Northern Gun corporation. Built during the Golden Age of Man, the building was designed well enough to survive the earthquakes of the Great Cataclysm, and has been maintained for centuries by Northern Gun as a symbol of humankind's tenacity and perseverance. It has all the gleam and sophistication that one would expect from Golden Age construction, though weathered by long decades of exposure to the point where no amount of restoration can make it look like new.

The headquarters is the meeting place for the Trade Council and one of Northern Gun's largest offices. While the research and development labs below the building were moved many years ago to their own complex, the headquarters is still the center of corporate operations. It has most of the company's history represented inside, by statues and mock-ups of their most famous products and paintings and photographs of important people and events.

The building itself is a 48 story skyscraper the likes of which are rarely seen outside of the Coalition States. It houses many of the company's high-ranking executives in secure offices above the 20th floor, as well as customer service, public relations and several branch offices. There is a large training center for up-and-

coming managers and shift bosses, an auditorium for lectures and meetings, and other services and amenities, including a demonstration lab that takes up most of an entire floor where new "toys" are shown off to the corporate leadership.

The first twenty floors are open to all Northern Gun contract employees. There are corporate cafeterias, a gym, classrooms for learning more about Northern Gun's products and sales strategies, and even a corporate firing range in the basement where employees can practice with their own personal weapons or familiarize themselves with new products. The rest of the basement is devoted to underground parking structures.

Floors 21-24 are all security. No elevator or stairwell goes through Floor 21, they all stop at or before the security levels. Executives and VIPs who need to get to the upper floors stop at 21 and are cleared to use special elevators that can only be reached from the security section.

Within the security levels are monitoring facilities for keeping watch over the entire building and the surrounding area. Cameras, infrared sensors and Coalition-style magic detectors are rigged throughout the headquarters, and reaction squads of guards are quick to appear if the surveillance center should report anything amiss.

Floor 22 contains all the major monitoring systems and emergency generator.

Floor 23 has a substantial armory that keeps the building's guards outfitted and equipped, stocked with everything from pistols to power armor.

There is a large **Loss Prevention Office (LPO) Division** on **Floor 24**. While the LPO headquarters is elsewhere, many of its top agents have offices at the corporate HQ and there are officers permanently assigned there as liaisons and security specialists. Should any problems occur at Northern Gun HQ, they are armed with NG weapons, body armor, and power armor, and prepared to respond at a moment's notice.

Floors 25-39 contain the bulk of the building's executive offices. Northern Gun is the largest existing sales and distribution network in America, next to the illegal Black Market, and the largest manufacturer outside the Coalition States. Coordinating the efforts of one of the planet's biggest corporations falls on the shoulders of the few dozen executives who work within these offices. From Mexico to Manitoba, from Nevada to Newfoundland, the fruits of their efforts are Northern Gun weapons and products that have spread near and far. Each branch or division of the company is represented in this VIP section with its own corporate office, even if, like the *Research and Development Branch*, they have their own headquarters elsewhere in the city. There is an executive lounge, four-star restaurant, tavern, numerous private meeting rooms and a few other luxury facilities for the higher-ups.

Floors 40-47 are the personal offices of the Trade Council and the highest-ranking executives and overseers of Northern Gun. Each floor is paneled with Red Oak from the forests of Ishpeming, lending a sense of class and sophistication to the upper corporate section that still represents the company's rustic roots. Each Trade Councilor has his or her own large, well-appointed office and offices for their closest staff members.

Floor 40 features an elegant executive dining room and kitchen.

Floor 41 has a small stage where presentations are made to the top brass and important guests.

The Trade Council's boardroom is on Floor 47, along with the office of the *Chief Councilor* and his or her staff. Access to this floor is restricted even to the other company executives and security staff are specially cleared by the Loss Prevention Office.

The top floor, Floor 48, is devoted to roof security and aircraft operations for the building's four helipads. Trade Council members often use their status to travel around Ishpeming by helicopter or hovercraft and landing right at the HQ is the ultimate in privilege and convenience. The security staff is paranoid about the top floor and the potential for supernatural flyers or jet pack-equipped attackers to get inside the building. They are also wary regarding the maintenance personnel who come to work on the air-conditioning and heating units, and the flight technicians who service the Trade Council's aircraft.

Notable Corporate Officers

CEO – Chief Executive Officer & Chairman: **Bradley Whitcomb**

P – President of the Company: **Ryan Fuerst**

VP – Vice President of the Company: **Lucas Buck**

CFO – Chief Financial Officer: **David Dunham**

CAO – Chief Accounting Officer: **Kerry Cook**

CIO – Chief Information Officer: **Shawn Johnson**

CRO – Chief Risk Officer: **Terrence Carter**

CSO – Chief Sales Officer: **Derek Boudreaux**

Automotive, President: **Douglas Rood**

Business Liaison, Director: **David Klett**

Business Analyst, Director: **Warren Nelson**

Chief of Bionics: **Michael Satran**

Chief of Engineering: **James Walker**

Chief of Loss Prevention Office: **Andrea Callister**

Chief of Robotics: **Joshua Hill**

Chief of Weapons Engineering: **Benjamin Barton**

Customer Service, Director: **Jorel J. Levenson**

Distribution & Logistics Specialist: **Shayne Lavender**

Internal Affairs, Director: **Todd Spencley**

Legal Department, President: **Dennis Hughes**

Managing Director: **Christina Liu**

Manufacturing, Director: **John Klinkel**

National Defense Director: **Timothy Letts**

Perimeter Defense, Director: **Brent Burnett**

Project Manager, President: **Bonnie Krueger**

Public Relations, Director: **Michael Copeland**

Human Resources, Director: **Scott Norman**

Research and Development, Director: **Federico Franceschi**

Risk and Safety Officer: **Kris Perlock-Campeau**

Sales and Promotion, President: **Kenneth Gunther**

Senior System Analyst: **Cody Dobbs**

Senior Weapons Officer: **David Keiger**

Senior Test Pilot: **Branden Loizides**

Security, Director: **Jason Lamb**

Other Areas of Northern Gun

Most of Northern Gun's **manufacturing facilities** are located in large belts of factories and warehouses that surround Ishpeming. Factories, and then entire districts of factories, sprung up as Northern Gun grew and the Upper Peninsula was reclaimed for humankind.

Residential areas. Homes, condominium style housing, and low-profile apartments fill in the area between Downtown and the

outer-rim of factories. Most "neighborhoods" are composed of one and two-story houses and condos. Schools, parks and small shopping areas are sprinkled throughout. Most are well kept with manicured lawns and small gardens. Apartment buildings are seldom taller than four stories and some neighborhoods are dotted with industrial parks composed of machine shops, warehouses and light manufacturing.

Hovertrains and traditional rail systems transport ore direct from the iron fields on the western border, and more comes from the fields around *Marquette*. Hovertrains are also used to transport workers and the civilian population.

Ships and barges unload their cargo at various ports around the city. From there, the ore, along with endless tons of other raw materials, is refined, processed, sorted, treated, and prepared, before being distributed to the various factories of Northern Gun and trade partners located in Upper Michigan.

A note about building size and security. While Downtown Northern Gun may have all the flash and glitz of the pre-Rifts Las Vegas strip, there is practicality to the architecture. Comparatively few buildings are taller than 8-12 stories downtown, and seldom more than 4-6 stories elsewhere, they have few glass windows, and many are designed more like Mega-Damage bunkers than office buildings or skyscrapers.

Tall buildings are impressive and eye-catching, which is exactly why Northern Gun avoids them. The taller the building, the more attractive a target. This is Rifts Earth. Northern Gun is a wealthy arms manufacturer. Attacks and raids are inevitable. Thus, the typical building seldom exceeds four or five stories in height, and one third have an equal or greater number of secure *underground levels* that can be sealed off from the ground floor. Most other average buildings have 1-2 basement levels and/or fallout shelters in case of attack.

Tall buildings are easy targets. The taller the building, the more likely it will be targeted, and the more susceptible it is to damage. Tall buildings also cause a wider radius of collateral damage and are more subject to partial collapse when upper levels are severely damaged. Explosions in the upper floors cause a rain-down effect to a much wider radius, resulting in damage to surrounding buildings from shrapnel and flying debris. Likewise, falling debris can block streets, shower street level pedestrians and defenders, and send clouds of flying glass and debris for several city blocks. Low, bunker-style buildings with few windows make difficult targets more easily defended from the ground and the air, and create much smaller debris fields when they are blown up or collapse. For these reasons, few buildings anywhere in Ishpeming, except Downtown, are taller than four stories.

Low-profile buildings, 1-6 stories tall are smaller targets, don't block one's view of the sky, and are easier to defend on a number of different levels. With the exception of *Downtown* – which is a deliberate showcase for product and intended to look big and impressive – most factories and buildings in Ishpeming are only 1-4 stories tall. Many factories and some warehouses look more like massive, M.D.C., concrete bunkers than traditional factory or warehouse buildings. Windows and glass are kept to a minimum and many factories often have 1-4 underground sub-levels. Even many warehouses have one or two basement levels where the most valuable stock is housed. Some buildings even have underground tunnels to concealed exits away from the building that lead to underground shelters. All of this is done for security and survivability should any portion of the city fall under attack. It is

a practice that extends to other cities and towns in the Ishpeming Republic and its neighbors.

Downtown Northern Gun

The majority of the downtown area is the **Market District** devoted to NG showrooms, stores, shopping plazas, sales and entertainment. The sprawling downtown area is all glitz, glamor and lights. For mercenaries and adventurers, it is rather like *Disneyland* or the *Las Vegas strip* of pre-Rifts Earth.

Downtown has wide streets that can accommodate giant robots, tanks and massive vehicles of all kinds. There are a lot of chrome, neon signs, spotlights and spectacle for all to see. Giant Robots are on display in outdoor plazas for sale, while others walk down designated paths or are stationed on select street corners, and piloted by NG defenders to provide city defense and to help enforce the law. Their presence, especially iconic 'Bots like the *Hunter Mobile Gun* and *Wolverine*, as well as Gladiatorial Robots on display, provide tourists with another sight to see, a photo op, and considerable peace of mind that the city is safe and well protected. And it is. Police clad in stylish power armor can be seen walking the streets, helping citizens and visitors, and riding police hovercycle interceptors throughout the city, with their greatest presence in the expansive "Downtown" area.

Some of the tallest and flashiest buildings in all of Ishpeming are found in the downtown area. The ground floors are almost always massive showrooms with tall ceilings. Likewise, the second and third floors above, and sometimes the basement levels are smaller showrooms, stores and shops.

Most showrooms are dedicated to a specific range of products: Giant robots, work 'Bots and cargo haulers, robot horses and animal companions, power armor, adventuring vehicles, combat vehicles, commercial vehicles, hovercycles, jet packs, water vehicles, aircraft (very limited), recreational vehicles, sports gear, wilderness exploration gear, hunting/trapping equipment, spyware, electronics, clothing, farm work vehicles and equipment, electrical generators, building materials, Body-Chop-Shops and bionic augmentation, and on and on. Think **MercTown** only 20 times bigger, slicker and more commercial, and dedicated exclusively to **Northern Gun** products. And that's just the hardware part.

Downtown is also where visitors can find all kinds of civilized, mostly family friendly entertainment: hotels, motels, movie theaters, live theater (plays, comedies, music), an orchestra hall, nightclubs, dance clubs, restaurants, bars, pubs, legal gambling casinos (clean and above board), stores and shops of all kinds. The only types of businesses not found are places that cater to magic, D-Bees and criminal enterprises. To keep Downtown Northern Gun a high-tech wonderland and playground for everyone from mercs and adventurers to visiting heads of state, farmers and families, half the business establishments are owned and operated by the NG corporation and all others are slick, clean and wholesome. There are no pawnshops, drug dens, rowdy taverns, illegal gambling, prostitution or seedy establishments allowed in the Market District. Places of ill-repute and questionable character are found on the outskirts of Ishpeming and at some of the other smaller, industrial towns that make up the greater Northern Gun area. Even then, they are nothing like the dumps, dives and dens of iniquity you encounter in many of the Chi-Town 'Burbs, MercTown, Ciudad Juarez and most other kingdoms and com-

munities. Northern Gun is civilized, wholesome, safe and law-abiding. Outside of the Kingdom of Lazlo, Chi-Town itself, Free Quebec, and some of the other fortress cities, Ishpeming/Northern Gun is one of the safest, cleanest and civilized communities in North America. There is no dark and dangerous underbelly. Even the Black Market has little presence or influence within Ishpeming and the surrounding area.

The Mall of Michigan

The Mall of Michigan is the largest single sales outlet anywhere in Northern Gun. It is a sprawling complex of shopping arcades, several NG warehouse centers and outlet stores, storefronts, restaurants and service centers. Virtually any basic item or piece of civilian technology can be acquired at the Mall, and for a price 10-15% lower than suggested list price elsewhere.

Located in the Downtown area, the Mall of Michigan is another part of the carnival experience and in-your-face showmanship the city has come to be known for. Thus, it is as much of a marketing device and promotional mechanism as anything else, and it works. Visitors are always wowed by the variety and availability of merchandise, and keep talking about NG products and their NG experience for years afterward. While the Mall of Michigan does host a huge number of shopping outlets and individual item sales run high, the lower profile and more practical showrooms and warehouse centers of Escanaba and Marquette are just as effective and profitable.

Still, the Mall of Michigan is a bustling retailers' paradise with stores that have the entire Northern Gun product line, as well as many competitors' non-military products and a wide range of wilderness exploration and adventuring goods, spare parts, practical clothing, survival gear and specialized equipment. One can outfit anything from a family to a mercenary company using what they find in the Mall of Michigan. New products premier at the Mall all the time, usually kicked off with food, drinks, free giveaways and prizes. Robo-Gladiators and other celebrities are often brought in for these events, and there were even a few *Erin Tarn* book signings many years ago when the Mall was much newer and smaller and the original "Traversing Our Modern World" had just appeared on Black Market bookshelves. Trade Council members, high-ranking Northern Gun executives and proud engineers all sometimes linger at the Mall in order to see the public's response to their products firsthand. There is a certain excitement in all the shopping and showmanship of the Mall, an element that is much lower key in Escanaba, where most sales involve mercenaries and state armies making bulk purchases by the crate and truckloads of prepacked equipment.

Clothing and Fashion in North America. Northern Gun's Mall of Michigan features a wide selection of different clothing, from the most basic work clothes to expensive and high quality brands. As a center of commerce, Ishpeming has many native entrepreneurs who run textile factories or clothing outlets; businesses that require the kind of stability found in Northern Gun.

The Huntsman's Choice line of S.D.C. (and M.D.C.) armors and light M.D.C. field clothing and other items is popular among Wilderness Scouts and outdoorsmen of all kinds. *The OperatorPlus* line of mechanic's jumpsuits, jackets and accessories is made for the many technical types who work for Northern Gun or buy its products, from factory workers to traveling Operators to full-time mechanics. They include numerous pockets and

straps for holding tools, as well as padded knees and elbows and a fireproof treatment that helps protect the wearer from burns. *The Fireblood Line* is stylish clothing, leather accessories, leather trench coats, gauntlets, body armor and gear designed for Juicers and Juicer wannabes. There are other specialized clothing lines such as combat fatigues with built-in webgear and uncommon camouflage patterns for mercs and adventurers; waterproof, buoyant work attire and clothing for sailors; as well as a line of clothing and gear with a Western/Cowboy look for those heading out to the Pecos Empire and the New West, and others.

In addition to clothing made for a specific purpose or occupation, there is also a good variety of standard civilian apparel and dress clothing. Mass produced, cheap clothing is cranked out for export and sale to those on a limited budget. High-quality, modestly-priced clothing that stands up to rough use and Michigan's winters is the norm in Ishpeming and throughout much of the Manistique Imperium. Both communities are relatively wealthy and stable, and mostly devoid of the rag-clad urchins of the 'Burbs and most small kingdoms and cities.

Howard Holland, Director of Operations, Quick Stats: Howard is a logistical genius who keeps the Mall running smoothly and the many shop owners happy. He also coordinates special events at the Mall. **Alignment:** Anarchist. **Attributes:** I.Q. 20, M.E. 19, M.A. 17, P.S. 10, P.P. 11, P.E. 12, P.B. 13, Spd 15. **Experience:** 12th level Rogue Scholar with connections within NG, the Black Market and most of the shop owners and other notable people in Ishpeming. This also means he keeps up on all the rumors and celebrity scuttlebutt.

John King, Head of Security at the Mall, Quick Stats: John has experience as a mercenary and private investigator. He is a good leader, dedicated to his job and incorruptible. **Alignment:** Principled. **Attributes:** I.Q. 14, M.E. 15, M.A. 14, P.S. 20, P.P. 13, P.E. 11, P.B. 12, Spd 21. **Experience:** 11th level Military Specialist with skills in surveillance, undercover ops, computers, and security.

Trigger-Quick Burgers & Fries

One thing visitors to Ishpeming are sure to remember is **Trigger-Quick Burgers and Fries**. More than just a single restaurant, Trigger-Quick is an entire *fast-food franchise* that has spread throughout the Republic of Ishpeming, the Manistique Imperium and even has a handful of locations in CS Iron Heart. Remember, fast-food restaurants and food chains are a thing of the past that vanished, for the most part, after the Great Cataclysm. So for many travelers on Rifts Earth, this is something new, different and interesting, plus the food is surprisingly tasty (better quality than pre-Rifts fast-food of the 20th Century) and amazingly fast compared to most traditional sit-down restaurants. Trigger-Quick is an actual chain of restaurants with a standardized food menu, food preparation, and prices. One can order a burger at any Trigger-Quick location and expect to receive the same food and service they have known to rely upon. Trigger-Quicks are found throughout the city of Northern Gun as well as at least a few in virtually every sizable city and town in Ishpeming, as well as at neighboring large cities in Manistique and the City of Brass in *CS Iron Heart*. They serve a few different types of burgers and fries, fish sandwich and fries, chicken sandwich and fries, chicken strips and fries, chicken salad, soft drinks, milkshakes, a few desserts and Trigger-Quick's famous "Bull's-Eye" onion rings.

Prices are dirt cheap (average meal costs less than 5 credits), but the food quality is very good and very fast (generally, less than a 5 minute wait). A few have even introduced something they call a "drive-thru window."

Brandon Aten, Owner, Quick Stats: Brandon is the owner who started the chain and is making a killing. **Alignment:** Principled. **Attributes:** I.Q. 18, M.E. 13, M.A. 21, P.S. 12, P.P. 12, P.E. 13, P.B. 14, Spd 12. **Experience:** 9th level Rogue Scholar. **Note:** He is considering starting a new chain of stores. One that combines playing parlor games and selling drinks and snacks. Like many businessmen in Northern Gun, Brandon has sponsored the creation of a few gladiatorial events at the Robodome, but has only won once. He also hosts numerous charity events for orphans and sick children.

The Robodome

Northern Gun is much too civilized and peace-loving to pit living combatants against each other in brutal, life and death gladiatorial games, even against monsters. So they came up with a tech-solution and created a new sport and spectacle: **Battling robots**. And it has become a hugely popular sport – one of the largest attractions in Ishpeming amongst visitors and locals alike. The place for these exciting games is the infamous **Robodome**. See the entire section devoted to the Robodome and Robo-Gladiators in **Rifts® Northern Gun™ Two**, for complete details.

Prototype Previews

Whenever a new Northern Gun product premieres, the corporation is sure to make a publicity event out of the occasion. The majority of new products are shown off in two places: the Mall of Michigan and the Central Sales Headquarters in Escanaba. The prototype demonstrations normally consist of trained technicians doing a little target shooting or taking the new vehicle or robot out for a spin on the test-track. Sometimes customers and shoppers are invited to test out the new weapon systems under controlled conditions on the gun range there, and take light vehicles (with weapon systems deactivated) for a ride on the test-track.

Most previews go hand in hand with early sales efforts. When a weapon, vehicle or product first appears, it is sold at a discount (usually between 10-20%) for the first week or two it is offered. The discount helps put the product in people's hands, and Northern Gun customers who return to their lives all over the continent spread word of the new item far and wide. Seeing it in use is normally enough to increase sales, and once the news is out, customers begin making requests and large purchasers ask about the new inventory.

Shawn Kennedy, Director of Previews, Quick Stats: Shawn loves marketing and promotion almost as much as the Northern Gun corporation. **Alignment:** Anarchist. **Attributes:** I.Q. 14, M.E. 12, M.A. 24, P.S. 10, P.P. 9, P.E. 13, P.B. 11, Spd 12. **Experience:** 11th level Rogue Scholar with skills involving communication, promotion and TV/Video.

Ed's Used Vehicle Emporium

Many of Northern Gun's robots, vehicles and products wear out or are damaged beyond repair as part of their normal working life cycle. The husks of giant robots, combat vehicles and scrap often find their way back to Northern Gun for salvage. All the

industrial cities of Upper Michigan salvage and recycle. In Ishpeming, there are dozens of scrap and salvage operations, large and small, happy to tear out usable components, clean them up, rebuild those that require it and sell them as spare parts, as well as recycle scrap metal and plastic, and sell them back to the Northern Gun corporation. Salvage and recycling is a huge business in Ishpeming with many outfits owned and operated by NG itself. There are also many private salvage and scrap yards, and places that sell spare parts and rebuilt engines, circuit boards, weapon systems and components.

The largest and most famous second-hand lot in all of Northern Michigan is **Ed's Used Vehicle Emporium**. It is a massive storehouse of vehicles, robots, hovercraft and mountains of spare parts, making Ed's Used Vehicle Emporium part *used car lot* (a very large one), part *warehouse store* and part *scrap yard*. The most expensive 'Bots and vehicles are showcased toward the front and inside the big warehouse showroom. Some are select items at bargain prices, to draw customers inside. Behind the used vehicles (including robot vehicles) is a large fenced-in area, topped with barbed wire and lights. Inside are junk vehicles, used items waiting to be cleaned up or salvaged, and mounds of spare parts and scrap. The more valuable parts are sorted and stored on open shelves under canopies and inside barn-like storage buildings. The best and fastest selling spare parts and weapon systems are kept inside the back half of the massive Emporium Store which is more like a giant warehouse with robots and vehicles in the front half and the rest lined with shelves 20 feet (6.1 m) tall.

Prices for purchasing "totaled" and severely damaged robots and vehicles are higher at Ed's and at other Ishpeming scrap yards thanks to the pressing need for Northern Gun spare parts and the robust secondary repair and modification market. Typically 2-3% of the original list price (where most scrap yards outside Upper Michigan seldom pay more than 0.5 to 1%). Sometimes Ed's Used Vehicle Emporium will pay as much as 8% if Ed and his Operators believe the robot or vehicle can be rebuilt and resold quickly, or contains a wealth of salvageable weapon systems, parts and power supply. Of course, vehicles that are truly just bricks of junk might only fetch 1,000 credits.

Used, working vehicles and robots, of course, command a better price, but Ed and company NEVER pay more than 50% of the original list price for a 'Bot or vehicle in excellent condition. A purchase price of 20-30% is the typical price for a 'Bot or vehicle in good to very good shape, half for "fixer-uppers" and "junkers."

Owner *Edward Sauerland* and his team of Operators take the purchased used vehicles, clean them up, may do some body work, fix obvious and known serious problems, and put them up for sale at around double what the Emporium paid for them, more for good looking items, but seldom more than 70% of the list price for a new one. Only vehicles in high demand and souped-up robots and vehicles with a number of special features and enhanced performance capabilities may sell for as much as the original list price or more. However, such high-ticket items are a rarity. Vehicles of most kinds are available, though most are older models.

Bargain Vehicles at Ed's. Bargain vehicles are rattletraps and old robots and vehicles not in tip-top condition. They look banged up and rebuilt, but most sell for 30-40% of the cost of a new one. All bargain vehicles have 40% less M.D.C., reduced speed and maneuverability (-1D4x10% to Spd and are -5% on Piloting skill rolls). Moreover, they are almost certain to be missing 1D4 standard features and/or a couple of weapon systems,

and have a hodgepodge of patchwork armor and no body work to make it look good. Still, it is a bargain and every one is guaranteed to work.

There is also a **scrap metal crushing operation and processing center** for metal and plastic, but both are away from the Emporium and customers. Out in the scrap yard, covered by tarps and arranged by model type, are millions of vehicle parts, components and subsystems. Ed and his staff, assisted by a few dozen NG Light and Heavy Labor Drones, are experts as sifting through the mountain of machinery and finding the exact piece a customer is looking for. Odds are, if you need it, Ed has it. (There is a 92% likelihood of success!) And at prices half the cost of a new part and just as reliable. All rebuilt parts are as good as new.

Ed's Used Vehicle Emporium also has an excellent **body shop and repair garage** on site and another in the industrial part of town. The Operators who work here are very skilled and known for their custom paint jobs and ability to paint designs, logos and characters on 'Bots and vehicles. The problem is, there is such demand for their services, even with the Operators' Room and other good shops in town, that a typical wait, especially for a custom paint job, is 2D4 weeks.

Edward Sauerland, Owner, Quick Stats: Alignment: Unprincipled. **Attributes:** I.Q. 15, M.E. 12, M.A. 22, P.S. 18, P.P. 13, P.E. 15, P.B. 14, Spd 11. **Experience:** 10th level Operator with a number of piloting skills and a bionic right arm. **Note:** As a hobby, Ed makes and enters gladiatorial robots to fight for prize money at the Robodome. He and his crew are friendly rivals with the guys from the Operators' Room, who also enter 'Bots in gladiatorial competitions. Both have had their share of triumphs and defeats in the arena.

The Operators' Room

The Operators' Room is the most advanced and exclusive mechanics' shop in the city. It is a candy store for gearheads and grease monkeys, tankers and pilots, and power armor commandos and adventurers. The most talented and creative Operators, Cyber-Docs and other technicians from the Midwest are drawn to the Operators' Room, a place where field armorers are artists and every war machine is a masterpiece.

Customers are greeted by polite, efficient receptionists. The Operators and mechanics of the Operators' Room are not chosen for their skill in public relations, so most customer interaction is left to others. The Operators' Room handles a huge number of jobs, so careful organization is a necessity, and there is a large staff to take care of it. Once the pertinent information has been recorded and a down payment made, customers are taken back to the *Build Floor*, a huge warehouse full of sparks and hydraulic lines and crews of workers. There they meet with the Operator in charge of their order and hammer out the technical details of repairs and/or custom modifications. Every standard Northern Gun vehicle accessory or upgrade is available, but the seasoned mechanics of the Operators' Room are typically looking for more challenging assignments. Swapping out weapon systems, replacing armor, cosmetic customization, stealth paint, souping-up speed and performance by 2D4+10% and personalized control interfaces are all routine tasks for the pros at the O.R. However, this quality workmanship comes at a 20% higher price than most other garages in town, and rush orders (within 72 hours) cost an additional 30%, but the workmanship is impeccable.

The Operators' Room is located conveniently down the street from Ed's Used Vehicle Emporium, so spare parts and bits of Mega-Damage armor are never hard to come across.

In addition to repairing giant robots and vehicles of every variety (including those not of NG manufacture), the O.R. has a Body-Chop-Shop for cybernetic augmentation and bionic upgrades that is also one of the best in town. Standard prices.

Stan Chesser Quick Stats: Stan is the owner of the O.R. **Alignment:** Scrupulous. **Attributes:** I.Q. 18, M.E. 14, M.A. 15, P.S. 17, P.P. 14, P.E. 12, P.B. 12, Spd 10. **Experience:** 12th level Operator. **Note:** For fun, Stan and his crew build and enter combat robots to fight for prize money at the Robodome. The O.R. team has won six times more than Ed at the Emporium, which keeps their friendly rivalry burning.

The Ishpeming Arms Hotel

Renowned for its luxury and service, Ishpeming's most famous hotel is the *Ishpeming Arms*. A favorite of Robo-Gladiators, mercenary commanders and NG Corporate Execs, "the Arms" is more than just a place to stay – it is an experience.

First, valets wait outside to take customers' vehicles. No matter how many wheels (or legs) the vehicle has, a skilled valet will take it and park it off somewhere unobtrusively. Guests' luggage is handled for them by robot bellhops that do not need to be tipped.

Standard rooms are equal to the most luxurious accommodations that can be found in most other places in the world. Suites are incredibly sumptuous; equipped with full-sized kitchens, whirlpool baths, 1-4 private bedrooms and a balcony that overlooks downtown Ishpeming. Normal rooms run 500 credits per night, while suites go for 2,000.

The entire building is only eight stories tall, but covers an entire city block, has a massive courtyard, gardens, a skating rink in the winter (duck pond in the summer), a large indoor swimming pool and three restaurants with courtyard dining.

The Arms is a good place to stay if one is looking to bump into Robo-Gladiators, other celebrities and well-to-do merchants, adventurers and travelers. Trade Council members frequent the Arms, as well as successful mercenaries, foreign diplomats and wealthy businesspeople. Secret meetings and exchanges often occur in its courtyard gardens, lobbies and corridors.

Chadd J. Leath, Owner, Quick Stats: Chadd is a perfectionist who strives to make the hotel the most luxurious, four-star experience on the continent. He enjoys socializing with his celebrity guests and powerful people. His parties are amazing. **Alignment:** Scrupulous. **Attributes:** I.Q. 17, M.E. 12, M.A. 22, P.S. 10, P.P. 9, P.E. 10, P.B. 11, Spd 11. **Experience:** 11th level Rogue Scholar with skills involving communication, promotion and TV/Video.

Jeffery Gilbert, Hotel Manager, Quick Stats: Jeffery is a cagey fellow who has his finger on the pulse of everything happening at the hotel and with his many celebrity guests. He and owner Chadd make a great team and have no secrets between them. **Alignment:** Scrupulous. **Attributes:** I.Q. 15, M.E. 18, M.A. 20, P.S. 10, P.P. 11, P.E. 14, P.B. 13, Spd 14. **Experience:** 10th level Vagabond with skills involving communication, computers and business (including Pick Locks skill).

Christopher Thomas, Head of Security, Quick Stats: Chris is the hotel "fixer," the guy who quietly and discreetly takes care

of problems at the hotel for the owner, and fixes "issues" the guests may encounter, including avoiding entanglements with the law and bad publicity. Sometimes, that includes fixing things that even the owner and the manager never know about. His services also include the acquisition of contraband. **Alignment:** Anarchist. **Attributes:** I.Q. 15, M.E. 18, M.A. 13, P.S. 22, P.P. 20, P.E. 14, P.B. 10, Spd 23. **Experience:** 9th level Freelance Spy. According to rumors, he served as a Sheriff in the New West or Pecos Empire in his youth, but Chris never talks about it.

The Hovertrain Terminal

The busiest part of town is, without doubt, the Ishpeming Hovertrain Terminal. A giant expanse of concrete berths and bays, the terminal is a stopping point for hovertrains laden with passengers – whether they be citizens, NG employees or visitors. Half-underground, the terminal consists of an upper section where vehicles park or drop people off, along with a control tower that watches over everything and insures that two hovertrains never try to cross the same space at the same time.

Below the surface is the hovertrain terminal. Huge tunnels bring the vehicles in from up above and down into the boarding areas. Elevators, escalators, stairs and moving sidewalks carry passengers around the central hub, and a giant, semi-automated cargo-sorting apparatus fills many of the surrounding maintenance rooms.

Hovertrains enter the respective tunnels radiating outward from the terminal on the outskirts of Downtown Ishpeming. Hovertrains are simply too big to navigate through the city without prohibitively interrupting traffic, so they are kept belowground, leaving the surface streets clear for pedestrians and private wheeled, legged and hover vehicles. The massive hoverdrives on hovertrains also have a tendency to blow pedestrians off their feet and make things uncomfortable at ground level, and confining them to tunnels mitigates this problem. Tunnels also help to keep them safe from possible attacks and raids.

Once loaded with passengers, the hovertrains depart using the same tunnel system. Cargo hovertrains typically load up and unload at designated depots around the factories and corporate areas of the city and Republic, joining the normal flow of traffic only when necessary. Of course, one of the main destinations is to and from the *Visitors' Depot* five miles (8 km) outside the City of Northern Gun.

The Old Rail Station

Before hovertrains became a ubiquitous part of Northern Gun's infrastructure, traditional rail lines did most of the heavy lifting. And they are still used today, though mainly for cargo hauling. There are still railroads that run from Ishpeming to Escanaba, across to Manistique, and inland at many points, connecting to logging camps, mines and small communities.

Normal trains are smaller and much cheaper than hovertrains, even though they require tracks, bridges and equipment like locomotive turntables. The expense of hovertrains means that many "less important" areas of the Republic are serviced only by dirt roads and conventional rail transit. **The Keweenaw Peninsula**, home to *Houghton* and the *Copper Island* mining region, is one such place, and many people prefer to take the hovertrain to *On-*

tonagon and travel to Houghton by water rather than endure the entire journey on one of Ishpeming's aging rail trains.

The Old Rail Station is a busy, large building with impressive masonry and tall windows. It was built during the 50s P.A., a testament to the refined image that the (then) *Kingdom of Ishpeming* was trying to create for itself. Sculptures and reliefs of Northern Gun robots and vehicles are carved into the building's facade, far more elaborate than the murals, billboards and sales promotions plastered across the hovertrain terminal.

Vanderman Castle

Former Ishpeming Royal Residence

Another popular tourist attraction in Ishpeming is the Vanderman Castle. Until the Kingdom of Ishpeming was rebranded as the Republic of Ishpeming, the Castle was off-limits to the public; a prestigious royal mansion that stood for the eminence of Northern Gun. Since the Vanderman family has been downgraded from "royalty" to "celebrities," the Castle has been repossessed by the Northern Gun corporation and converted into a kind of museum and cultural center.

Tickets are sold at the front door (15 credits for adults, 5 credits for children under the age of 13), and the entire experience is a look at the history of Ishpeming and Northern Gun. A few preserved placards, vehicle parts and a few showpiece old vehicles with the words "Northern, Inc." etched into them hail back to Northern Michigan's Golden Age past. Photographs, maps and artifacts from before the Great Cataclysm and the subsequent Two Hundred Years Dark Age are there to be gazed upon in wonder, as well as examples of some of the first weapons and vehicles that Northern Gun produced. There is also a section for the Kingdom of Ishpeming years and records, plus photos and artifacts of Northern Gun as it rose to economic prominence. The outdoor courtyard is filled with a display of the most notable NG robots, power armor and vehicles from throughout the ages.

In addition to the historical museum, many videos and audio presentations, guests can tour the luxurious Vanderman estate. For those who have not seen the magical opulence of the Federation of Magic or the enchanted gardens and parks of Lazlo, the Vanderman estate is a slice of life that they cannot even imagine. Higher-ups within the Coalition States don't live as well as the Vandermans once did. The impressive grounds, large, highly ornamental house and manicured lawns and gardens are a far cry from the typical rubble-strewn streets of an average post-apocalyptic city-state.

Louis "King" Vanderman

Former King of the Kingdom of Ishpeming

For many years, the political state dominated by the Northern Gun corporation was technically a kingdom like so many other Rifts-age settlements. Northern Gun has been in control since the Dark Age, but in order to make Ishpeming seem more legitimate, they appointed a "king" and declared the country the Kingdom of Ishpeming. A few years ago, the *NG Trade Council* reevaluated their position, however. Surveys of Northern Gun customers seemed to show that the status of the nation of Ishpeming had little to no effect on their purchasing patterns. Within just a few days, the old "Kingdom of Ishpeming" was replaced by the brand

new "Republic of Ishpeming," an act that required changing a few signs and removing the figurehead king, but little more.

When the country was considered a kingdom, Louis Vanderman was its final king. The fifth generation of his family to hold the title, Vanderman was born into wealth and privilege, only to have it all stripped away in his late forties. Surprisingly, the experience has not left him bitter. He gets a stipend from Northern Gun that would make most people dance with joy, he enjoys working as a PR spokesman and diplomat, and shoulders little actual responsibility. One might be worried that Vanderman would become ambitious and decide to install himself as actual King of Ishpeming, or sabotage Northern Gun, but neither is the case. Vanderman never really cultivated connections with the military or political power structure, and is very much a pretty boy and party animal who enjoys his cushy life of privilege. Neither he nor any member of his family are willing to sacrifice that. He has always been a celebrity in function and king in name only. It is the "title" of king that has been stripped away from him. He remains a recognized celebrity and well paid corporate spokesperson.



King Louis Vanderman, Quick Stats: Though many assume he must resent being dethroned, Vanderman is okay with it. His position comes with many perks and a calendar filled with social functions. He likes not having many responsibilities beyond PR and being a celebrity spokesperson for Ishpeming and NG. **Alignment:** Anarchist. **Attributes:** I.Q. 15, M.E. 11, M.A. 22, P.S. 10, P.P. 11, P.E. 13, P.B. 17, Spd 14. **Experience:** 8th level Rogue Scholar and former King. **Notable Skills Include:** Computer Operation, Creative Writing, Dance, Gambling, I.D. Undercover Agent, Literacy American, Performance, and Public Speaking.

Kristopher Akers, Bodyguard, Quick Stats: Kris is the strong, silent type who stands in the background but is quick to

take action to keep the King safe. Guard to the King is a good paying gig, but Kris always keeps his ears open to opportunities on the side. **Alignment:** Anarchist. **Attributes:** I.Q. 15, M.E. 18, M.A. 12, P.S. 22, P.P. 15, P.E. 14, P.B. 13, Spd 14. **Experience:** 8th level semi-retired Bounty Hunter. **Psionics:** 53 I.S.P. A Major Psychic with these abilities: Empathy (4), Nightvision (4), Object Read (6) See the Invisible (4), Sixth Sense (2), and Telekinetic Leap (8).

NGMI Central Bank

The central hub of the Northern Gun/Manistique Imperium credit system is found in downtown Ishpeming. The NGMI Central Bank is a magnificent structure, designed by several talented architects and festooned with sculptures and statues, many of them of famous people and products from Northern Gun's history.

On the main floor are rows of tellers, and offices that service big-name clients, as well as a few well-appointed meeting and presentation rooms. Offices for the bank staff and executives are located upstairs, along with the bank's boardroom and other facilities. Deep within the center of the bank, in a sub-basement, are the mainframes and computer cores that keep track of the credits in circulation and tie accounts to individual cards. The cards function just like paper bills, and once a given number of credits have been placed on a card they are considered transferred from the bank to a spendable holding card. If the card is lost or stolen, the credits go with it.

A system that automatically debits purchases from users' accounts is not possible throughout most of Rifts Earth, as communication with a central server requires reliable connections that simply do *not* exist. Within Ishpeming and Manistique, however, individual credit cards are common, and usable at any retail outlet that has a hardline or radio connection to the NGMI Central Bank Network. Like modern day credit cards, these cards can be backed up, insured against theft or loss, and connected to various accounts with different spending limits.

The Central Bank oversees shipments of cash destined for Escanaba and Marquette every day. Mercenaries provide security for these transfers, which involve either paper credits, vouchers or pre-credited NGMI bank cards. Cases of theft are rare, though occasionally a few of the security personnel will try to pull an inside job and disappear with a pay shipment. The Loss Prevention Office (LPO) is especially vigilant when it comes to this kind of crime, and is not shy about putting out *kill orders* on mercs and bandits who think they can steal from Northern Gun and simply walk away.

Once the cash has left the city proper, it is up to the security people to get it through the lightly populated wilderness. Shipments go west towards Houghton to be exchanged for copper and furs or to Ontonagon to pay the troops of *Task Force X*. The most common run, however, is currency exchange with Escanaba. So much commerce is conducted out of Escanaba/MercBay that new cash supplies have to be brought in at all times. So many various credits are cashed in that overflow from the NGMI bank in Escanaba is taken by hovertrain to the main bank in Ishpeming to be sorted through and processed.

Coalition States Embassy

Standing proudly in downtown Ishpeming is an imposing, monolithic M.D. building with a pair of Coalition banners dangling from it. The Coalition flag flies overhead, and this spot is technically Coalition soil. It is the Coalition embassy, a symbol of hate and of changing times to the D-Bee population of Northern Michigan. To human supremacists and the leaders of Northern Gun, it represents a more secure future, part of a larger political system.

The embassy is a large, eight story, bunker-style building, more of a compound, really, with a picturesque courtyard at the center and a rooftop garden for meetings and parties. Also on the roof is a sky-dock for accommodating SAMAS patrols, helicopters, and Death's Head Transports, the primary means of resupply and exchanging personnel for the CS Embassy. Inside, CS citizens receive the papers that allow them to travel or work within Michigan and neighboring CS Iron Heart across the lake. They must routinely check-in to make sure their paperwork is up to date and that they don't "disappear" in hostile country.

Ishpeming natives who wish to apply for Coalition citizenship can do it here; many people claim the application process is 1-4 years faster this way than going through the massively overloaded 'Burb system. Whether this is true or not, a small trickle of people do manage to become CS citizens via Northern Gun/Ishpeming (unofficial preferred consideration).

The guards and embassy staff are all selected for their loyalty to the CS and come from Chi-Town and other States. It would be extremely embarrassing to have even a few low-ranking guards defect or run away from the Coalition, much less an ambassador or ranking official. To safeguard against this, only the most dedicated soldiers and proven civilian personnel are allowed to serve at the embassy. Soldiers are expected to conduct themselves properly and impress an image of professionalism upon the local populace. Most of them would rather die than leave the Coalition States and are virtually impossible to corrupt or pay off. The fringe benefits of working in Ishpeming are a nice bonus, and most troop assigned to the embassy are career soldiers who have been given a cushy assignment as a reward for service before they are promoted to new positions or retired.

Blake Moorcroft, CS Ambassador, Quick Stats: The Ambassador has been rewarded with the cushy NG post for years of dedicated service in the Coalition Army. His reputation is that of a staunch CS hardliner, but the truth is Blake has always been out for himself. He is a master of skullduggery, backstabbing and politics, and adept at "playing the game" to get ahead and stay ahead. Thus, Ambassador Moorcroft receives a wide range of special considerations and rewards for putting Northern Gun's interests ahead of the Coalition's. This has guaranteed his turning a blind eye to the presence of D-Bees, mages and other people of "questionable character" doing business in Ishpeming, as well as NG practices that might be considered inappropriate. His every report to Chi-Town is favorable to NG. **Alignment:** Aberrant. **Attributes:** I.Q. 18, M.E. 19, M.A. 24, P.S. 12, P.P. 14, P.E. 13, P.B. 12, Spd 10. **Experience:** 10th level CS Military Specialist (still has his SAMAS power armor).

James L. Giltz, Head of Embassy Security, Quick Stats: Captain Giltz is a friend who served under Moorcroft in the Coalition Army and was appointed to the NG post as a favor. He is a veteran soldier with good skills and an eye for treachery, trickery

and danger. His loyalty is to Moorcroft and himself first, then the CS. **Alignment:** Anarchist. **Attributes:** I.Q. 15, M.E. 12, M.A. 13, P.S. 21, P.P. 19, P.E. 14, P.B. 10, Spd 15. **Experience:** 8th level CS Commando. He also has a SAMAS and other armor and gear.

Manistique Imperium Embassy

Much more utilitarian than its Coalition counterpart, the five story Manistique Imperium embassy is a working building, processing thousands of citizenship requests, dual-citizenship forms, work permits, shipping permits, arrest warrants, mining claims and a wide range of business and trade documents. The close relationship between Ishpeming and the Imperium means people are frequently visiting and engaging in commerce together, and even switching citizenship, moving from one nation to the other or conducting business across borders. The LPO (Loss Prevention Office) also works closely with Manistique law enforcement to track down criminals who think they can escape by border-jumping, and both countries are known to contribute to bounties on the heads of notorious pirates and criminals. In fact, the two work together on all matters of national security, including patrolling the Great Lakes and battling piracy, raiders and banditry.

The embassy includes at least one representative from each of the city-states of the Manistique Imperium. Manistique is the capital and preeminent city of the Imperium, but each of the city-states has a certain measure of independence and is free to negotiate its own trade terms. Enterprising Northern Gun employees are always looking for city-states willing to purchase or trade for NG equipment at advantageous terms. Due to this competition and intrigue amongst the city-states of the Imperium, its embassy has become a hotbed for spies and information theft.

Brian Hatherly, Ambassador of Manistique, Quick Stats:

A fair-minded merchant and politician who is diligent and good at his job. He, like so many people of Manistique, have a love/hate relationship with NG and resents Ishpeming's arrogance and superiority. **Alignment:** Scrupulous. **Attributes:** I.Q. 14, M.E. 18, M.A. 20, P.S. 11, P.P. 10, P.E. 12, P.B. 12, Spd 9. **Experience:** 9th level Vagabond with skills involving communication, computers and business (including Math).

Otherworldly Animal Reserve

On the outskirts of Ishpeming is the expansive Otherworldly Animal Reserve – part zoo with an area of cages and enclosures and part animal preserve. It is a large section of forest and former farmland that has been ringed with electrified M.D.C. fences, moats and concrete walls. When Monster Responders capture dangerous creatures alive, they are sometimes sent to the Otherworldly Animal Reserve rather than be destroyed. Here there are sections for Fury Beetles and Spiny Ravagers, Rhino-Buffalos, Heliodons, and others. There is an entire dinosaur zoo section where the Reserve's collection of the beasts are exhibited outdoors in the summer and kept inside a heated enclosure in winter.

There are prehistoric Ice Age creatures like mammoths and mastodons that are shown off year-round, along with the Reserve's hardier monsters. No intelligent animals are kept penned inside the Reserve (at least, that the park rangers know of), and the openness of the park lets the animals behave in a natural manner. There are numerous observation platforms and Mega-Dam-

age viewing windows that provide a good view of the creatures. Safaris inside armored ATVs are also popular, letting visitors drive safely amongst the giant monsters of Rifts Earth.

Kris Main, Zoo Manager, Quick Stats: Kris loves animals and loves running the Reserve. Always has an eye out for making the park better and for exotic animals to add to it. **Alignment:** Scrupulous. **Attributes:** I.Q. 13, M.E. 17, M.A. 15, P.S. 11, P.P. 9, P.E. 10, P.B. 11, Spd 15. **Experience:** 10th level Rogue Scientist with skills that emphasize biology, zoology, and animals.

Ishpeming's Granaries & Farmland

Outside the warehouse districts and rows of factories, Ishpeming's farm country begins. Towering grain silos dot the horizon, full of tons of corn and wheat that feeds the citizens and guests of Northern Gun. Should an emergency scenario unfold (Xiticix invasion, demon plague, etc.), the silos hold almost a year's worth of foodstuffs and make the entire nation resistant to a trade embargo or siege. A certain percentage of every farmer's output is contributed to the national reserves, only tapped into in times of need.

The farmland that surrounds the capital is safe and well-cared for, but has a somewhat brief growing season and long, cold winters. Ishpeming's farmers have learned to deal with the weather, and rely on sophisticated agricultural machines provided by the Northern Gun corporation to bring in the harvest. Thanks to robot farmhands and M.D. plowshares, the limited number of farmers in Ishpeming are able to feed the populace with little worry of famine and lean times. Combined with imports from Manistique and the Coalition States, Ishpeming is well-fed and cases of malnutrition and starvation, so common elsewhere, are almost unheard of inside the country.

Beyond the large belt of farmland surrounding the capital, forests and the wilderness begin. Unlike the rest of the continent, however, these forests are dotted with cabins, small farms, logging camps, miners and trappers. The presence of Northern Gun and the vigilance of the country's Monster Responders make the woods a relatively safe place to explore. Monsters and strange animals are still common, however, and hikers should take care to bring along proper precautions.

Charles Erroy, Agriculture Councilor

Agriculture Councilor Charles Erroy is tasked with overseeing the production and safety of the nation's crops. Ishpeming has long winters and imports much of its food from other states around the Great Lakes, but its farmland is safe and untroubled by monsters from the Rifts. Add to that the high technology that Northern Gun makes available to its farmers and it becomes clear how Ishpeming's farms can compete with more southern operations.

Erroy is a combination minister of the interior and food safety czar. Farms, woodlands and commercial fishing are all under his purview. Food collection and safety are the two priorities that have to be balanced out. Refrigeration and proper food storage are not easy to maintain in the post-apocalyptic world, especially for those who work in the wilderness. Spoiled fish and rotten produce can be life threatening, and the Agriculture Councilor's job is to make sure that the average citizen does not have to worry about such things. As a result of his work, food standards have

risen dramatically within Ishpeming's cities, and are slowly beginning to catch up in outlying communities as well.

Charles Erroy, Councilor, Quick Stats: What few people know about Charles Erroy is that he has a past as an adventurer he seldom talks about. Rumor has it that he ran with a tough crowd of mercs and adventurers in the Magic Zone and Pecos Empire, and even fought vampires. **Alignment:** Unprincipled. **Attributes:** I.Q. 25, M.E. 15, M.A. 20, P.S. 18, P.P. 15, P.E. 17, P.B. 14, Spd 9. **Experience:** 10th level Robot Pilot.

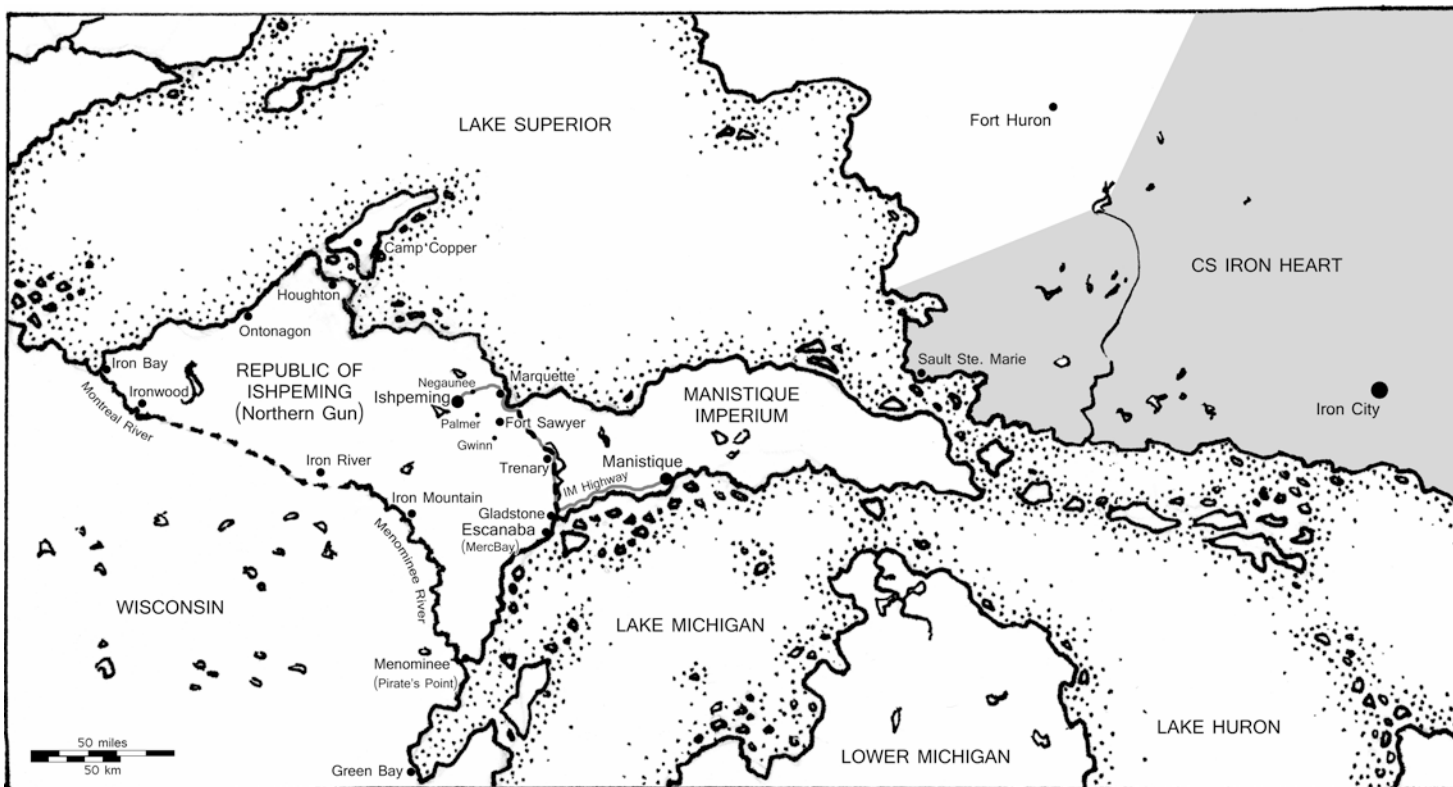

The Ishpeming Region

Center of Northern Michigan Civilization

In addition to the sprawling capital city of Northern Gun/Ishpeming, the *Ishpeming region* is also home to several other large, industrial cities. Ishpeming's port at **Marquette** is well known, but many outsiders don't consider the smaller cities of **Palmer**, **Negaunee** and **Gwinn**, or **Fort Sawyer** when they think of Northern Gun. All these communities are located near the capital (Northern Gun/Ishpeming), and all have sizable populations. Suburbs and outlying villages and farm communities have grown up between the cities themselves. Ishpeming and its surrounding cities are all loosely connected by neighborhoods, warehouse districts, farms and well-maintained roads, making them one large, semi-urban zone with small expanses of forest in between them.

Outside of that central area though, most of the land claimed by the *Republic of Ishpeming* is forest with patches of farmland and some homesteaders and trappers. There are forts, mines and villages along the western border with *Wisconsin*, and large cities at **Houghton**, **Ontonagon** and **Escanaba**, but travel away from these population centers, and you are in dangerous woodlands. The Upper Peninsula has always been lightly populated, and remains that way even now that it has become a sanctuary for humankind.

Fort Sawyer

Included as part of the Ishpeming Republic

Fort Sawyer is the name that was given to *Sawyer Air Force Base* during the Two Hundred Years Dark Age. Located only about 10 miles (16 km) from Ishpeming, the base was another haven for humanity when the *Coming of the Rifts* threatened the very Earth itself. Many military and civilian aircraft diverted to Sawyer when larger air force bases were destroyed or overwhelmed beyond capacity. The soldiers and weapons that built-up there helped the people of the Upper Peninsula weather the storm of magic and monsters that washed over the planet.

Now, generations later, Fort Sawyer is an air base once again. Its old runways and hangars have been renovated or replaced, and the fort is the primary design complex and proving ground for new Northern Gun aircraft and flying power armor. The company's new line of helicopters, hovercraft and planes are all found at Sawyer, and secret experimental designs are to be found in the fort's hangars and labs.

The farmland and countryside to the west of the fort regularly report sightings of strange lights and unidentified aircraft, almost always at night. These are top-secret projects, things Northern Gun does not yet want their competitors to be aware of. Sometimes test-flights head north, out over Lake Superior, for even more secrecy and isolation.

In addition to its use as the **NG Aircraft Development Center**, Fort Sawyer is the center of the Republic of Ishpeming's air-traffic control and radar warning system. Powerful radar stations are sited at *Ishpeming, Marquette, Houghton, Ontonagon, Escanaba, Gladstone, Menominee* and *Ironwood*, tied together to give Ishpeming some semblance of radar coverage. All of their input is received at Fort Sawyer, where the data is analyzed for threats. If a problem should arise, a mercenary company equipped with various aircraft is kept on standby just to protect Ishpeming's skies. Should their forces not be adequate to the task, other mercenaries and flying power armor forces can be called in or Northern Gun pilots organized into attack squadrons.

Marquette

Included as part of the Ishpeming Republic

One of the main reasons Ishpeming survived the Great Cataclysm so well is its landlocked location within Michigan's secluded Upper Peninsula. As Northern Gun expanded and turned into the center of a commercial empire, Ishpeming needed a better outlet to the rest of the world. The majority of Northern Gun's products have always been shipped south by hovertrain or traditional rail to *Escanaba* and *Gladstone*. From there they make their way around the *Great Lakes* and are sent out to customers and way-points across North America. Ishpeming, however, is much closer to the *Lake Superior* coast than that of Lake Michigan, and the city of *Marquette* has grown to become its primary port and the center for most trade with CS Iron Heart and lake shipping destined for the Manistique Imperium.

In addition to its value as a commerce hub and naval base, the ruins of *Northern Michigan University* are also located at Marquette. The city all but disappeared with the Coming of the Rifts, but as it was resettled and redeveloped during the expansion of Northern Gun, it has yielded an incredible amount of scientific and academic knowledge. The university's libraries and technical laboratories were disassembled piece by piece and reconstructed back in Ishpeming, and played a significant role in the technological renaissance that has created Northern Gun as we know it today.

The modern city of Marquette is arranged around the port. There is a well maintained road that is part of the Ishpeming-Manistique Highway and leads from the port directly to Ishpeming itself. Using this thoroughfare and the four rail lines that run along it, Northern Gun is able to keep a constant volume of products moving in and out of Marquette. Defending the port is a high priority, and the coastal defenses found in Marquette are second only to the shore guns that protect Escanaba. Marquette is, in effect, part of Northern Gun. Outsiders even think of it as one of the suburbs.

Marquette Naval Development Center

Along with its commercial port, Marquette also hosts a high-security area: **the Northern Gun Naval Development Center**. Just as Fort Sawyer is the center for aircraft development, Marquette and the frigid waters of Lake Superior give life to Northern Gun's ships and submarines. Recent models like the *Beachmaster amphibious robot* and a variety of water vessels are products of the Marquette labs. While ship hulls for Harbormaster patrol boats and others are laid down in Gladstone, the first prototypes were built and tested in Marquette and sailed down through the river at Sault St. Marie. Where locks were once needed, the river has widened and deepened to such a degree since the Great Cataclysm, that the locks are no longer necessary.

The development center comprises several large, sheltered docks where new ships can be constructed away from prying eyes. There are also four submarine pens where new designs for subs are in progress. Inland are laboratories and workshops that connect to the special, highly-secure docks. Privateers and naval captains from *Task Force X* and the small Northern Gun Corporate Security Fleet are coming and going all the time, testing out new ships, offering their feedback and participating in drills and inspections.

Hannah Gaspard

Shipping & Ports Councilor

Hannah Gaspard is the first female S&P Councilor in Northern Gun's history. She is a former freighter captain who was just another Northern Gun customer for years. She began taking work directly from Northern Gun corporate back in 100 P.A., and built herself a strong working relationship with the company over the next seven shipping seasons. Before long, Gaspard was organizing shipping for all of Escanaba, and within two years was offered the same job for the entire country.

Unlike most of the rest of the Council, Gaspard did not rise through the ranks of Northern Gun corporate structure. She was sought out and hired for the job for her particular expertise and her knowledge of the Great Lakes and the various ports of Ishpeming. She has much in common with Field Marshal Reeves, in that they are both outsiders who were brought in to perform their current jobs and have only gradually become part of the Northern Gun social elite.

Hannah Gaspard, Councilor, Quick Stats: Alignment: Unprincipled. **Attributes:** I.Q. 17, M.E. 14, M.A. 23, P.S. 14, P.P. 11, P.E. 15, P.B. 17, Spd 10. **Experience:** 12th level Merchant Marine.

The IM Highway

Running 103 miles (165 km) from Northern Gun, capital of the Ishpeming Republic, to Manistique, capital of the Manistique Imperium, is the **Ishpeming-Manistique Highway** – better known simply as the IM Highway or just “the IM.” A collaboration of the Northern Gun Trade Council and the royal family of Manistique, the IM highway is the most active land-link between the two nations, and follows along their mutual border for most of its length.

In a world with few paved streets outside of city centers, the Ishpeming-Manistique Highway is truly unique. It is a fully

paved stretch of road that leads from one city-state to the other with no portages, no rickety rope bridges or dirt trails through dark woods. The road was built along the course of the old *Route 41* and *Route 2*, pre-Rifts motorways that once linked the Upper Peninsula. It is well-lit, mostly safe and kept in good repair.

Crews from Ishpeming and the Manistique Imperium can be encountered during non-winter months working on the highway. Damage must be repaired before it can interrupt traffic, and monsters and supernatural creatures that have taken up residence within the woods always make projects more difficult than they have to be. Giant robot traffic also rips up the road much worse than tracks or tires, and workers are always laboring to fill in the deepest footprints. During the winter, automated plows manage the heavy snowfall along the highway.

In addition to functioning as a trade route and border between the two nations, the IM highway also serves a definite military purpose. Not only does it connect the neighboring countries, it also cuts north-south through the entire Upper Peninsula. If a threat to Ishpeming were ever to emerge, troops from either the northern or southern coasts could swiftly reach the other side of the peninsula or the nation's capital. The highway links Ishpeming to *Marquette*, its principal northern port, along with the cities of *Gladstone* and *Escanaba*, the two main shipping outlets on the southern coastline. Should the need arise, it also runs all the way to *Manistique* (as its name implies), and military relief from one nation or the other would use the IM highway to come to its neighbor's assistance in time of emergency. So far, this threat has not emerged, but the massive amount of commercial and civilian traffic that uses the highway makes it a worthy venture for each of the contributing nations.

Dangers of the Highway. *Trenary*, a small community midway along the highway, houses a small defense force that guards the lengthy interior. The IM is well maintained and monitored by troops from both Ishpeming and Manistique and *Trenary* defenders in the middle, but the IM highway can still be dangerous. It stretches over many miles of thick forest terrain that is difficult to patrol, especially at night. Attacks by Highwaymen, Bandits, Raiders and other rogues are more common than either country would like.

Con Artists have learned to use the highway to steal money and goods, and gather information they can sell. They hitch-hike or pretend their vehicles have broken down and wait for a passing good Samaritan to stop. The con artist then hitches a ride to get information about the goings-on in the area, particularly new shipments coming and going, problems with security, etc. Armed with information about deliveries and arrivals, the con artist may sell that information to bandits and raiders for a small percentage of the stolen goods or for cash or trade goods up-front. Others hijack the truck or break in to a train boxcar or warehouse (often with accomplices/teammates) to attempt to steal the goods. Still other con artists ply their trade to be accepted and travel from place to place, get handouts and to steal whatever small valuables they can (credit cards, side arms, electronics, jewelry, drugs, booze, and whatever they can) and pawn or sell them before their victims even realize the items are gone. Others steal the vehicle itself at the first opportunity. These IM Con Artists always know the latest rumors and news, but may charge for that information. The Loss Prevention Office is particularly incensed by this kind of crime and routinely sends agents disguised as hapless truckers

and travelers down the IM. Their orders are to bring back car-jackers and con men dead or alive in order to discourage further criminal action along the highway. So far, the efforts of the LPO haven't worked.

Monsters and supernatural beasts are a much less frequent problem, but they do happen from time to time. While "normal" monsters stalk the woodlands, the lack of ley lines and nexus points means there is little to attract powerful demonic beings or creatures of magic. That said, there is the occasional Sasquatch sighting and infrequent incidents involving *Armored Slayers*, *Loup Garou*, *Windigo*, *Wishpoosh Demon Beavers* and *Faerie Folk*. In fact, the enigmatic *Faerie Bots* seem to have increased in numbers in Upper Michigan, perhaps attracted by all the technology and spare parts available. *Fury Beetles* are probably the most common and troublesome of the "big monsters" mainly because of their size and the unintended damage they do to crops, fences and property. (All the creatures noted above can be found in **World Book 20: Rifts® Canada**.)

The traffic and military activity along the highway also dissuades dangerous animals from making themselves known; most are hunted down by mercenaries eager for bounties the moment they are reported to be in the area.

The Annual IM Highway Multi-Marathon. Every year, towards the beginning of May, the Republic of Ishpeming and the Manistique Imperium hold the annual IM Highway Multi-Marathon.

The Multi-Marathon is a "casual" 103 mile (165 km) jog along the IM highway for nearly its entire length. The run is grueling in its length and departs from the highway at many points to wind through the woods and follow scenic trails. It is a contest recommended only for Juicers, Crazyies, Cyborgs and D-Bees, and relatively normal looking non-human competitors are generally tolerated and permitted to compete.

The race begins in Manistique. It is always a party, an excuse for a big public gathering that kicks off the start of spring. There is a parade where the runners are delivered to the starting line, and throngs of fans line the highway even beyond the city limits. The race follows along the border between the Republic of Ishpeming and the Imperium, sometimes deviating slightly to pass through a border town or crossing. The course is basically four marathons back to back, and is a 6-8 hour event even with superhuman competitors.

The final stretch of the race begins as the Manistique border ends near the pre-Rifts site of *Harvey*, Michigan. The last 20 miles (32 km) follow the shoreline up from Harvey to Marquette, then cut inland straight to Ishpeming. And for anyone who thought the party at the start of the race in Manistique was big, the celebration in Ishpeming is overwhelming. It ranks right up with New Year's Eve and the Robodome Championship Finals in August, as one of Northern Gun's biggest spectacles. Cameramen on the backs of hovercycles film the runners as they make the home stretch. This is the most competitive portion of the race, as anyone who has toughed it out to this point will be making a big, final push for the win. Dirty tricks and violence are both common in the last few miles and the crowd loves both, even if the race's referees do not.

Trenary

Trenary is a small, rural community. A large portion of its population is farmers, fishermen, river cargo haulers, loggers, trappers and hunters. Their community has been given a second lease on life thanks to the IM highway. Located just a few miles southwest of pre-Rifts Trenary, the small, modern city is sited at the confluence of several rivers. Before the IM Highway went up, Trenary was essentially just a logging depot, a stopping point for lumber shipments following the dirt roads north to Ishpeming or south to Manistique. With the construction of the highway, Trenary found itself as the only pit stop along its route within the heavily forested center of the Upper Peninsula. Travelers stop at Trenary at all hours of the day to resupply, stop and eat, and rest for the night. As a result, dozens of bars, hotels, diners, quaint shops and fueling stations have appeared within the last few years.

The rivers that run through Trenary are also valuable transportation routes, even with the highway in place. **Dexter Creek** and the **West Branch Whitefish River** run through excellent logging country and farmland. Barges full of timber and fresh produce go up and down the rivers during spring and summer. There isn't much for sale in Trenary except for fresh produce, home-cooked food, baked pies and pastries, local crafts, vehicle fuel and Solid Oxide batteries. As most visitors are either going to or coming from one of the great shopping meccas in North America, Trenary has to rely on local charm and cuisine. However, the city is a **Black Market haven**, with shipments and caches of illegal goods (including drugs) available at discreet locations in town and drop points in the woods. The Black Market runs several of the taverns, a Body-Chop-Shop, and both brothels in the small city, and has other illicit entertainments available.

In order to watch over the city and protect the highway, Trenary houses a large garrison of the IM Highway Patrol, half of whom are Trenary residents. The Patrol is overseen and managed by Northern Gun's Loss Prevention Office. LPOs and Patrolmen travel the highway and some side roads like pre-Rifts State Troopers on hovercycles, patrol cars, flying power armor and light aircraft, all of which zoom up and down the IM watching for trouble and helping travelers. They do what they can to suppress the Black Market in Trenary as well, though allegations of corruption and bribery are a routine problem for the Highway Patrol and LPO working out of the Trenary branch office.

The Lake Michigan Coast and Southern Ishpeming

Apart from the Ishpeming city region, the Republic's most populous area is the Lake Michigan coast. The southernmost portion of the country, the coastline is largely sheltered by islands, the remains of the various peninsulas that used to protect Green Bay, and is home to many fishermen, lake cargo haulers, and privateers (and some independent pirate gangs) who ply both the bay and Lakes Michigan and Huron. The coast is densely settled, with small communities every few miles and farms, houses and cottages interspersed throughout. Things remain relatively suburban until one starts to head down the road towards *Menominee*.

For while Menominee is a good-sized city, the woods around it are lightly inhabited on the Ishpeming side of the border and a haunted land over in Wisconsin.

Outside Escanaba, the *Green Bay coastline* is surprisingly quaint and peaceful. **Pirate raids** do occur from time to time, but the overwhelming response that Northern Gun sends in after such events is making them a rarity. Most pirates go and attack vessels out on the open lakes, retreating back to the bay only to take refuge and shelter their ships. The southern coastline is a common *retirement destination* for Northern Gun employees, mercenaries and wealthy foreigners looking for safety and security but unwilling to settle inside the Coalition States. With Escanaba to the northeast and Menominee to the southwest, southern Ishpeming is its own little world, even within the larger Republic.

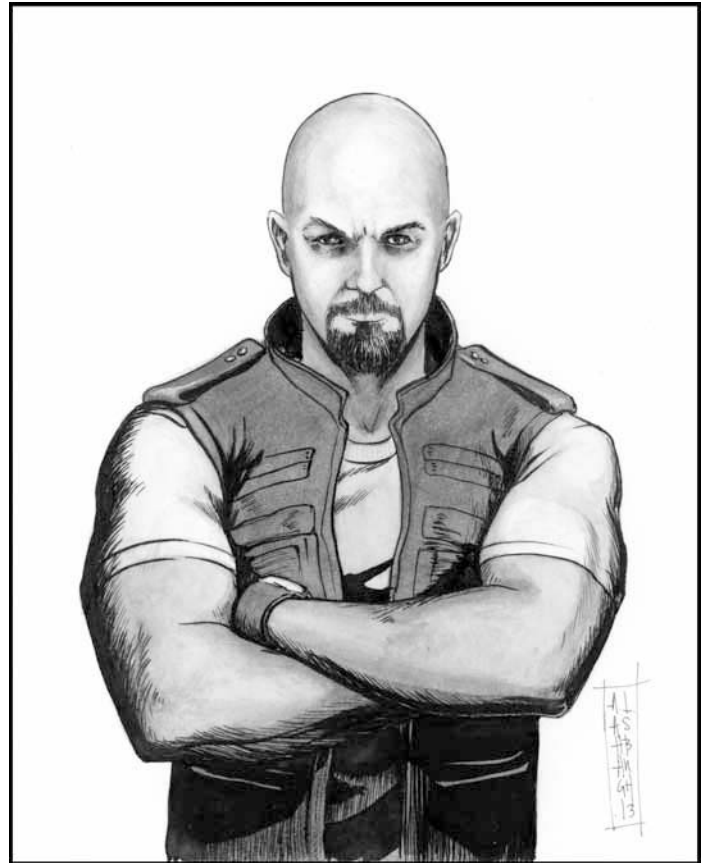

Escanaba – “MercBay”

While Ishpeming may be the capital of Northern Gun, Escanaba is its doorway to the world. Located on a promontory along Ishpeming's southern coast, Escanaba is within easy reach of anyone traveling across northern Lake Michigan and close enough to the Manistique Imperium for day trips. It is the Republic of Ishpeming's principal port, the hub for shipping NG goods to the rest of the world, and the most frequent shopping stop for mercenaries, privateers, pirates and state militaries. It is believed that more weapons are sold, in bulk, out of Escanaba than any other single place in North America (the City of Northern Gun/Ishpeming is second). More than Stormspire in the Federation of Magic, more than MercTown or Arzno or even Manistique.

Known colloquially as “MercBay,” Escanaba is a city built with customers and logistics in mind. The entire community is designed with wide concrete streets, easy accessibility to and

from the docks, hovertrain and conventional rail systems, hundreds of warehouses, and an array of stores, shops and garages with weapons dealers, sales centers, dry-docks, repair facilities, Juicer clinics, Body-Chop-Shops, restaurants and supply depots all within easy reach. It has the same variety of stores and entertainment as the City of Northern Gun/Ishpeming but built for function, without all the flash and showmanship. Think simple, functional warehouse store vs dazzling showroom.

For those looking to stay more than a few hours, there are hotels (60-120 credits a night), hostels (40-70 credits) and bunkhouses (10-20 credits a night) available further inland, typically increasing in quality the further one gets from the controlled chaos down by the docks. Restaurants, brothels, storage facilities and parking structures are all found in this district. Further inland yet are Northern Gun corporate warehouses and service centers, connected to the docks by underground tunnels. Adjacent to the IM Highway and the railroad tracks that run along it, the corporate portion of Escanaba sees a constant flow of goods going to restock the sales outlets on the coast.

MercBay is also the site of the quarterly *Escanaba Airshow*. Spectators thrill as planes, helicopters, rocket cycles and flying power armor all twist and turn overhead in high-speed races, death-defying tricks and stylized faux-firefights. The Airshow is an attraction for the whole family, but definitely contributes to a monthly spike in sales to mercenaries and non-military customers. Special sales and offers usually coincide with the event, and new aircraft always debut at the Airshow before even being seen at Ishpeming and other Northern Gun outlets. The Airshow is run and coordinated by NG exec and flying ace, *Jason DeLong*.

The Airshow isn't Escanaba's only attraction, and traveling shows, visiting Robo-Gladiators and *small-scale Robodome League games* are also found here. Theaters, drinking halls, Juicer sports arenas, gladiator games, live shows and other entertainments are set up to attract visitors and bring tourist credits into the city. All of this may be icing on the cake compared to the incredible volume of military weapons and NG equipment that goes through Escanaba, but to anyone other than wholesalers, the nightlife and the amenities are the really memorable part about the city.

Escanaba is a melting pot of various cultures from North America. While the D-Bee population is less than 5%, the humans found in Escanaba are the most diverse anywhere in Northern Michigan, maybe the entire continent. Visitors from the Coalition, Manistique, Free Quebec, Lazlo, New Lazlo, the Federation of Magic, Tolkeen, Whykin, Kingsdale, and even the New West and Canada have all resettled in Escanaba, or may be living there for a short time.

The Escanaba Docks

The docks at the City of Escanaba are some of the busiest in all of North America. Boats and ships are constantly coming and going, dropping off or picking up shipments of cargo or passengers. Sometimes vessels come into port just for the ship-servicing facilities, probably the best in the continent outside the Coalition and Free Quebec. Almost any damage can be repaired and any upgrade applied, from scraping a few zebra mussels off the hull to extending the size of the vessel or swapping out a power

source. Cranes and dry docks of all sizes are present to help out in the process.

Not far from the docks are hundreds of warehouses and secondary service providers. Doctors, shopkeepers, Operators and others whose clientele often visit for a short time are located right there, convenient for anyone who doesn't wish to explore the town. Pirates, prostitutes and con artists also frequent the docks, looking for new marks fresh off a ship.

The docks are also a haven for pirates, bandits and Black Market thieves. In all the hustle and bustle, a few missing crates won't even be noticed, and the blast of a ship's horns can disguise a gunshot or the cries for help of someone being dragged off into the shadows. Nearby ships also provide an easy escape route, and despite the restrictions on submerged travel, there are always Smugglers, mages and thieves willing to attempt to run past the harbor patrol in sea scooters and mini-subbs or via a bit of magic.

Products from Manistique. Manistique City, the capital of the Manistique Imperium, is also located along Lake Michigan and has its own docks and shipping centers. For most customers who come to Northern Michigan, however, MercBay is one-stop-shopping, and any product that is unavailable there will not even receive consideration. To make up for this, the Imperium has a trade deal in place with Ishpeming that allows it to sell its products from warehouses and outlets in Escanaba. **Wellington** weapons and equipment are off-limits (to limit competition for arms sales), but virtually anything else can be found. So many Imperium products are sold out of Escanaba that some visitors (most notably Erin Tarn) have mistakenly assumed that MercBay is an independent kingdom, or one of the city-states of the Manistique Imperium. In reality, it is thoroughly under the control of Northern Gun and the Republic of Ishpeming.

Purchasers and Resellers. A vast number of the ship captains and merchants visit the Escanaba docks not just to drop off or pick up cargo, but to buy weapons and vehicles for themselves. They are either looking for specific items to deliver to a specific customer or searching for good deals they can later resell themselves at some distant frontier port or faraway kingdom. For many practitioners of magic, mercenaries, D-Bees and criminals, it is preferable to use *a middleman* to acquire goods and supplies, and hiring a ship's captain to act as such a middleman is quick, easy business. Most Great Lakes captains are well-known and are asked few questions about their acquisition, regardless of what it may be or how out of character the purchase may be. A community of "Purchasers," as they are known, has developed to meet this need, their job being a combination of a traveling merchant, freelance ship captain and Black Market smuggler. They live off the commission they charge their customers for procuring goods from Escanaba and delivering them safely over the Great Lakes to a predetermined location. A location that can be another port or a secret drop point on shore or with another vessel in the middle of the lake.

Piracy is a crime and frowned upon, but bold and cunning pirates dare to resupply, buy and sell goods and find rest and relaxation at MercBay. To keep the peace, the law tries not to ask too many questions, so pirates who keep a civil tongue and a low profile can come and go from the port city without incident. Only the most infamous and obvious can expect trouble from the local lawmen, mercs and bounty hunters.

The Discount Docks

Set a bit apart from the main port area, the Discount Docks are known as Escanaba's designated bargain section. Many of the sales outlets in Escanaba, Ishpeming and elsewhere sell their defective gear by the ton to merchants down at the docks, eager to unload inventory they cannot sell themselves. Finding the rare, non-broken purchase is a lucky coincidence, but there are gems to be found and deals to be had.

Almost anything can be found in this sprawling, open-air market, but only the most ramshackle equipment finds its way to the Discount Docks. Here, the prices for damaged, used, old but like new, and salvaged parts are extremely good (50% of list price), but anything purchased from the many bargain bins has to be examined carefully. Many are old, rusted, malfunctioning, worn down or actually broken. On the other hand, many items may be scratched, dented and look like junk, but work great or can be fixed very easily. In short, there are many great bargains provided you know what you're looking for.

The Discount Docks are also home to traveling merchants and "day sellers" who rent a location on the street or in an empty stall in a number of flea market-like warehouse buildings for a day or two. At these locations, discounts may range from 25% to 70%, but this is also where nifty thieves, bandits, pirates, raiders and Black Marketeers sell stolen goods right out in the open and the really good stuff (translation "hot as Hades" stolen goods and contraband) under the table. There are, of course, many legitimate vendors, including established merchants looking to sell old and damaged inventory, professional discounters, antique dealers, pawnshop dealers, refurbishers, junk dealers, traveling merchants, and mercenaries and adventurers down on their luck looking to sell whatever they can spare to cover debts or go home.

Richard "Fathom" Hill, Merchant Marine Captain, Quick Stats: Fathom is a well known Merchant Marine who buys cheap and sells at a modest profit to poor communities all around the Great Lakes, and sometimes beyond. Captain Hill is a retired Privateer (some say pirate with connections to the Black Market) with a good reputation in Escanaba. **Note:** Over the years, Fathom has taken privateering contracts with Northern Gun, the Imperium, Free Quebec, and the Black Market, among others. Though he claims to be retired, many believe it is a cover for his current, secret contractor. **Alignment:** Anarchist and has a soft spot for the underdog. **Attributes:** I.Q. 15, M.E. 13, M.A. 12, P.S. 14, P.P. 19, P.E. 13, P.B. 18, Spd 11. **Experience:** 9th level Privateer (see **Rifts® Sourcebook Four: Coalition Navy** for this and other naval O.C.C.s).

Downtown Escanaba

Just on the other side of the docks is the beginning of Escanaba proper. Hotels and gambling houses, private homes and offices are all located in this part of town. There is a sprawling downtown district that caters to the needs of visiting mercenaries, adventurers, NG customers and tourists, complete with casinos, restaurants, theaters, bars, clubs and culminating in the Escanaba Robodome.

For those looking for something other than the games, the rest of the city provides a wide range of entertainment, from pubs, taverns, nightclubs and dance halls, to movie houses, live theater, concert halls, gymnasiums, a sports stadium and other activities.

Visitors can also find a level of comfort and accommodation few other places on the continent can offer. While there isn't much in the way of culture to be found, the average visitor to Escanaba doesn't miss it. Warm beds, a hot shower, indoor plumbing, good food and general security are a luxury in themselves on Rifts Earth, especially to hard-fighting mercenaries, loggers, traveling merchants and adventurers.

Spending a few credits, though, will open many doors in Escanaba. The entire city is about making money, and those who are willing to part with their hard-earned cash will be well taken care of. There are both hostels and fine hotels, food carts and five-star restaurants. Every Northern Gun product available is for sale, and if some specific product should happen to be sold out, more are probably already on the way from Ishpeming. That said, there is very little corruption, and bribes do not generally work, even at restaurants.

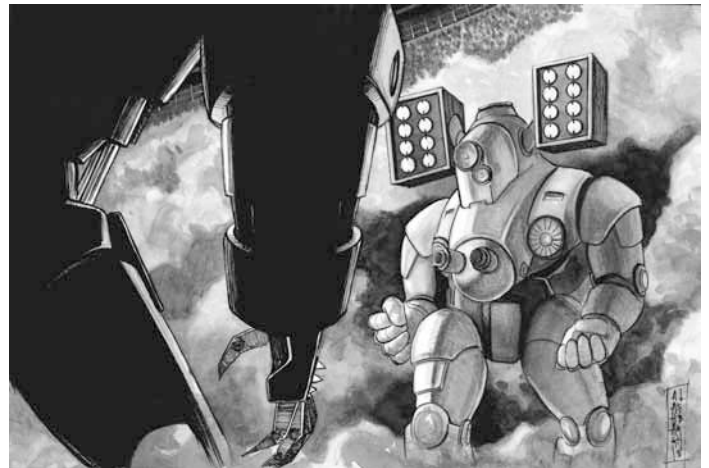

The Escanaba Robodome

While not as large or opulent as the original Robodome in Ishpeming, the E-Dome sees most nights of the week and has a constant rotation of visiting competitors and mercs who have spontaneously decided to participate in the night's games. This random element is really played up by the managers of the Escanaba Dome, and every evening of games features Random Card Matches where unscheduled competitors are divided by weight class and paired off when cards with their names written on them are drawn by visiting VIPs or audience members. Robo-Gladiators are always shuttling back and forth between Escanaba and Ishpeming for matches and at least one night a week, one of the three champions from Ishpeming hosts the Escanaba games and sometimes competes. The events at the E-Dome are lively and unpredictable, and many fans and sports gamblers prefer the Escanaba Robodome's events to the more choreographed, theatrical bouts of the big league in Ishpeming.

Arnaldo Lefebre, Robo-Gladiator, Quick Stats: Arnaldo is the reigning champion at the E-Dome. He has 27 wins and has won the last five local competitions. He's also a three-time winner at the Northern Gun Robo-Dome but has better luck in the smaller arena at MercBay. According to some, rumor has it he is a spy from Free Quebec or Old Bones. Other rumors say he is a retired pirate from Montreal. Arnaldo laughs off all accusations and refuses to speak of his past. **Alignment:** Scrupulous. **Attributes:** I.Q. 12, M.E. 17, M.A. 13, P.S. 18, P.P. 24, P.E. 19,

P.B. 9, Spd 11. **Experience:** 10th level Robot Pilot specializing in Gladiatorial robot combat.

Will Sproul, Robo-Gadiator, Quick Stats: Will is a local resident who is known for his wild antics at the E-Dome. He is a Crazy who was born in Escanaba but spent much of his youth engaged in adventure and military campaigns across Canada and the Northern United States, including the Juicer Uprising and confrontations with Xitix and Daemonix. “Wild William” seldom wins a robo-competition due to his erratic behavior, but is always entertaining to watch and a fan favorite. He is a local celebrity most famous for abandoning his gladiator robot and challenging power armor and robot opponents just clad in his body armor or claptrap power armor. He loves roughhousing, fighting and competitions, and drinks like a fish. **Alignment:** Scrupulous. **Attributes:** I.Q. 10, M.E. 11, M.A. 14, P.S. 24, P.P. 25, P.E. 19, P.B. 8, Spd 31. **Experience:** 8th level Crazy, 2nd level Robot Pilot. **Psionics:** I.S.P. 68. Intuitive Combat (10), Machine Ghost (12), and See Aura (4).

Escanaba Airfield

The site of the popular Escanaba Airshow, the Airfield is part Northern Gun public relations and part corporate supply hub. Broad-winged cargo planes come and go at all hours of the day and night, and smaller aircraft and hover vehicles transporting VIPs make use of the terminal and airstrip as well. Important supplies like critical parts and design secrets go by plane rather than the hovertrains that carry bulk items, and the Loss Prevention Office also stages many of its operations out of the Airfield.

Brett Easterbook, Airfield Operations Manager, Quick Stats: Brett is the brass-tacks logistics wizard who keeps the Airfield running smoothly. He is so good at his job that he seems to be in three places at once and never sleeps. Another loyal and dedicated NG employee. **Alignment:** Scrupulous. **Attributes:** I.Q. 14, M.E. 14, M.A. 10, P.S. 18, P.P. 21, P.E. 13, P.B. 9, Spd 10. **Experience:** 11th level Vagabond Pilot specializing in running a business and flying aircraft.

The Escanaba Airshow

Once every three months, the site is opened to the public for the Escanaba Airshow. Grizzled mercs and young families alike crowd together to see Northern Gun’s newest aircraft, prototypes and old standards pushed to the limit by daredevil pilots. Old favorites like the Sky King are never absent from the show, but brand new helicopters, jet packs, planes and flying power armor are the real main attraction. Audience members get to see new products up close and personal, then watch in awe as they take to the sky in a series of races, acrobatic displays, formation flying and other impressive maneuvers. Sales reps tout the improvements and performance statistics, demonstrate cool features and do anything they can to generate a buzz of excitement regarding new products.

Airshow pilots are celebrities on par with Robo-Gladiators within Northern Gun. They are part race car driver, part test pilot, part stuntman, and their job is to make aircraft do things they were never intended for. Impressing the Airshow crowd gets harder every year, and contraptions like souped-up and modified power armor and aircraft, jet packs and wing packs have all been used to produce some pretty spectacular stunts.



Jason DeLong, Airshow Director, Quick Stats: Jason is a semi-retired Robot Pilot who has traded in the adrenaline rush of combat for the thrill of the cheering crowd and spectacle of aerial derring-do. Jason owns the largest known collection of flying power armor in North America with many of them on display at the airfield museum. Among them are the NG-Samson, three different styles of SAMAS and a Quebec Violator SAMAS (all armed and working). The presence of the SAMAS suits has led to rumors in some circles that Jason is a CS spy. **Alignment:** Anarchist. **Attributes:** I.Q. 14, M.E. 14, M.A. 10, P.S. 18, P.P. 23, P.E. 13, P.B. 9, Spd 10. **Experience:** 10th level Robot Pilot specializing in flying armor and aircraft.

The Hub

Escanaba’s busiest district is the docks, no question about it. But coming in at a close second is “the Hub,” the rail/hovertrain depot and shopping district that connects to both the docks and the IM Highway. Passengers and cargo come and go from all over *Ishpeming*, *Manistique* and *CS Iron Heart*. There are conventional rail lines and loading stations, large bays for hovertrains, shuttle services that run back and forth to the docks and the onramps that lead right to the IM Highway. As a result, there are warehouse centers, retail outlets, shops, and places to eat and drink located all around the depot. This is ideal for people who have a connecting train to catch and don’t have time to go downtown, or fear the docks are not safe.

The frenzy of activity may be intimidating to those not used to large crowds and even larger machinery, but the Hub is all laid out in an extremely simple manner. The rail train station is at the center, with three different hovertrain loading areas around

it. The first is for traffic to and from Ishpeming. The second departs for border towns along the Imperium and into Manistique to the capital city itself. The third hovertrain area is for hovertrains heading west, on their way to Menominee, the Iron Fields, and the cities of the Iron Chain.

Matthew Bollman, Depot Manager, Quick Stats: Known as “the Man” by all who work with Bollman, he is the gent who manages the Hub. As a result, he always looks tense and busy, yet somehow remains calm even when dealing with 20 things at once. He is well-liked and respected. **Alignment:** Scrupulous. **Attributes:** I.Q. 18, M.E. 15, M.A. 12, P.S. 9, P.P. 8, P.E. 14, P.B. 12, Spd 15. **Experience:** 11th level City Rat turned administrator, but still has many connections on the street as well as amongst many businesses at NG and Manistique.

Lower Michigan Limited Company

Escanaba is home to the *Lower Michigan Limited Company*, a tour outfit that makes regular trips to the wilderness of the lower peninsula. LMLC’s experienced guides know the northernmost portion of the peninsula well, and are somewhat familiar with the western and eastern coastal areas of Michigan and southeastern Canada. They use small, fast boats and the occasional helicopter to deliver groups of adventurers, hunters, explorers, and thrill-seekers to locales that fit their interests. At least one “native guide” – usually a Wilderness Scout, Psi-Stalker, Dog Boy or Native American – is strongly suggested. Cost is 100–400 credits per each guide, per 24 hour period; the higher the cost, the more experienced the individual (up to 8th level). Reduce cost by half for short excursions that last only 4–6 hours. With or without a guide, a time and place for extraction is arranged. Miss it, and you are on your own to find your way home. Wilderness Tours can be any of the following: A simple trek through the wilderness, camping, exploration expedition, salvage operations (exploring ancient ruins for relics and artifacts), game hunting (S.D.C. animals such as game birds, deer, etc.), and big game hunting, literally “big” as in hunting bear, Fury Beetles, Rhino-Buffalo, Ostrosaurus, Aqua-Hydras, Dragonfish, Water Serpents, Giant Waterstriders, Giant Leeches, and other large, dangerous animals. (**Note:** Many of the beasts listed are described in **Rifts® Sourcebook Four: Coalition Navy**). Big game hunts may also include hunting intelligent monsters such as Xiticix, Black Faeries, Brodkil, Demons, or even Horune Pirates and other dangerous beings that are known to prey upon or attack humans, but at a 50% premium as hazard pay for the guide(s).

Anyone looking for an interesting wilderness expedition or salvage mission, LMLC will get them there. Once on shore, the result is up to the customers and luck. **Note:** All fees are paid in advance and there is NO guarantee of success or of a safe return. All customers sign-off to free LMLC of any liability for loss of property and loss of life.

Kerry “DeadFall” Reed, LMLC Guide, Quick Stats: Kerry is one of the most popular guides working at LMLC. He is smart, capable and knows the forests of the entire Northern Michigan, eastern Wisconsin and Ontario Canada better than most humans. Kerry is a cagey individual skilled at finding game animals for his clients; he never engages in salvage operations, only hunting and exploration. He has only ever lost one client under his care. **Alignment:** Scrupulous. **Attributes:** I.Q. 13, M.E. 14, M.A. 12,

P.S. 22, P.P. 20, P.E. 19, P.B. 11, Spd 18. **Experience:** 10th level Wilderness Scout.

Tyvernos “Danger” Oriflamme, LMLC Guide, Quick Stats: Ty, a Wild Psi-Stalker, is another popular guide, renowned for his courage and derring-do. For Ty, no request is too crazy or too dangerous, and he is often willing to waive the 50% hazard pay if the expedition sounds fun or challenging. Ty also has the highest record (nobody else even comes close) for number of fatalities (42), serious injuries (219) and lost property (don’t ask). Yet he is consistently among the top five most requested LMLC guides for those looking for dangerous adventure. **Alignment:** Anarchist. **Attributes:** I.Q. 12, M.E. 19, M.A. 10, P.S. 19, P.P. 17, P.E. 20, P.B. 9, Spd 25. **Experience:** 9th level Wild Psi-Stalker. **Psionics:** I.S.P.: 156. All standard Psi-Stalker abilities and bonuses, plus Intuitive Combat (10), Meditation (0), Mind Block (4), Object Read (4), Remote Viewing (10), and See the Invisible (4).

NG Bounty Registry - Escanaba Office

One of the busiest of Northern Gun’s *Bounty Registry offices*, (the others are in Ishpeming, Menominee and MercTown), the Escanaba Bounty Registry is a gathering point for mercs, adventurers, specialists and soldiers for hire. New business is posted every day and announcements made hourly for the benefit of illiterate Bounty Hunters and mercenaries.

Not only is the Registry itself helpful, but the presence of so many like-minded men-at-arms can also have its benefits. Improvised teams and on-the-spot partnerships often form right there inside of, or outside on the steps of, the Registry building as mercs join forces to accomplish a particular job. A merc company that has just accepted a new assignment may realize that they are in need of a specialist. Someone with the necessary skill set or special abilities, and that somebody is probably nearby and looking for work.

Robert Dugan, Manager of the Escanaba Office, Quick Stats: Robert is a retired Bounty Hunter who enjoys helping his “brothers-in-arms” find work. He knows a great deal about bounty hunting and the NG Bounty Registry has connections to dozens and dozens of different merc outfits. **Alignment:** Unprincipled. **Attributes:** I.Q. 15, M.E. 13, M.A. 14, P.S. 21, P.P. 15, P.E. 14, P.B. 12, Spd 10. **Experience:** 9th level Robot Pilot specializing in flying armor and aircraft.

Shaun Savage, A Merc Company Commander, Quick Stats: Colonel Shaun Savage is leader of the Savage Riders, and frequently recruits temporary help and specialists at the Escanaba Office for various missions. **Alignment:** Anarchist. **Attributes:** I.Q. 18, M.E. 14, M.A. 24, P.S. 21, P.P. 20, P.E. 14, P.B. 11, Spd 15. **Experience:** 8th level Headhunter Techno-Warrior (see **World Book 20: Rifts® Canada** for more details about different types of Headhunters).

The Patrol

The mercenary company that functions as Escanaba’s police force and defenders is known as *the Patrol*. See the **Ishpeming Military Contract Network** section, page 62, for complete details on this group and its key leaders.

The Patrol's Jailhouse

Located near the docks is a building made out of Mega-Damage materials and ringed with razorwire fencing. Its windows are barred and its doors controlled by electronic keycards. Inside, the Patrol houses the troublemakers it arrests on Escanaba's streets. There is a standard drunk tank that sees a lot of use, cells for augmented or physically powerful perps, the normal lockup, a processing center and several solitary confinement cells. The jailhouse also has a motor pool out back and a mechanics' shop where the Patrol's Operators work to keep their law enforcement vehicles and gear working at 100%.

No one stays long in the jail. Criminals are either handed over to the Ishpeming authorities for prosecution, released after being fined or held overnight, or escorted to the docks and asked to leave. Those with no means of getting out of the city are taken to **Menominee** and dumped south of the border in *Old Wisconsin*. Criminals on the Coalition's Wanted Lists are put in irons and extradited to the CS, usually Chi-Town, but sometimes Iron Heart, within 24 hours of capture.

Rumor has it that the jailhouse also has a secret basement with a half-dozen small, isolated cells. These cells, if they really exist, are said to house the most notorious and high-value criminals the Patrol arrests. Rather than hand them over to the Ishpeming authorities right away, the Patrol is rumored to use torture and psychic techniques to extract valuable information before auctioning their freedom off to whichever Bounty Hunter, Mercenary Company, Black Market Faction or state agency has the highest bid. Some Black Market types even claim that the Patrol uses its authority to abduct and arrest people wanted inside the Coalition States and other kingdoms, people who should be legally safe within Ishpeming. If true, the Patrol has managed to hide the practice from the Northern Gun Trade Council for years. Then again, the NG Council would be happy to have nefarious criminals such as these gone, no matter how they disappear.

Escanaba's Northern Gun Corporate District

Beyond the lights of downtown, the warehouses and supply depots begin again. Northern Gun has to keep Escanaba well stocked at all times, and the corporate district lets NG stockpile goods nearby without taking up valuable space at the docks or downtown. A dozen small rail lines link the corporate district with the shopping centers down at the docks. They have been built inside underground tunnels, both to save space and to keep curious visitors away from the NG supply chain.

Janet Fielding, Escanaba Councilor

As the overseer of Escanaba, Janet Fielding is essentially the *Vice President of Northern Gun*. While the Manufacturing and Labor Councilor has his hands full with the corporate side of the job, the Escanaba Councilor is tasked with overseeing the densely populated city of Escanaba and its surrounding region. That includes the busy port that is one of Northern Gun's most valuable assets. The naval base and corporate shipping center at **Gladstone** is also within the jurisdiction of the Escanaba Councilor,

and Fielding is responsible for defense of the southern coast and maintaining a steady shipping schedule.

Escanaba is the second largest city in Northern Gun, and home to a large population of customers, temporary workers, mercenaries, visiting tourists and other non-citizens. It is a magnet for wealth and power, a large city in its own right that is third only to the population and resources of the City of Ishpeming/Northern Gun and Manistique themselves. Fielding rules over Escanaba like an appointed queen, subservient to the Chief Councilor in Ishpeming and no one else. She is a stand-up and moral individual, and could be exploiting her office for much greater personal gains if she desired.

Janet Fielding, Escanaba Councilor, Quick Stats: Janet is a high-minded idealist dedicated to Northern Gun first, and the people of Escanaba, second. She is a tough, smart and resourceful lady who knows how to get things done. Only fools and idiots delude themselves into believing they can get the upper hand on her. **Alignment:** Principled. **Attributes:** I.Q. 20, M.E. 15, M.A. 21, P.S. 17, P.P. 12, P.E. 18, P.B. 15, Spd 9. **Experience:** 13th level Rogue Scholar.

The Escanaba Road

As Ishpeming's largest trading port, Escanaba is an absolutely vital city and commercial asset that must be connected to the capital and manufacturing centers of Ishpeming. The Escanaba Road links the city to the *Ishpeming-Manistique Highway* and also stretches south, along the coast of Lake Michigan, until it reaches Menominee.

Between Escanaba and the IM Highway to the north, the Escanaba Road is large and well developed, basically an extension of the highway. All the road traffic that passes between Ishpeming and Escanaba must take this leg of the Escanaba Road. It is well patrolled, maintained and lit. South of the city is the other leg of the road, the connection between *Escanaba* and *Menominee*. This coast road is 55 miles (88 km) of scenic woodlands and lake views. It sees much less traffic than the IM Highway, but is still one of Ishpeming's most heavily used travel routes. The road isn't as wide as the IM Highway, and there are long stretches without streetlights, but it is still a proper road and reliable for use by street vehicles. The road does follow *Green Bay*, and pirates do attack truck caravans and travelers from time to time, but the *Lakeguard* and the *Loss Prevention Office* both do their best to keep things safe.

Escanaba Coastal Defenses

Escanaba isn't just Northern Gun's principal port and largest sales center. It also serves as the public face for **Gladstone**, the company-only port and NG naval base sited further up the coast. The guns of Escanaba both defend the city and prevent any pirates or raiders from getting close to Gladstone. "Spotters" in *Blue Hawk power armor* patrol the air over the bay during clear weather, ready to guide in artillery fire and missiles on anyone foolish enough to test the coastal batteries.

To complement the long-range weapons, simple obstacles have also been left in Escanaba and Gladstone's approaching waters. Hollow balls of steel or concrete, they are attached to lengths of M.D.C. chain and anchors, then allowed to float at a designated depth. The position of the obstacles means that small vessels can

go right over them, while larger ships with deeper drafts will be smashed to pieces. This lets fishermen and speed-boaters follow the coast unimpeded while keeping unwanted larger ships and submarines out. Clearly marked channels lead through the obstacles, strips of water that have been pre-sighted by coastal artillery. Any vessel that tries to plow through the obstacles will attract a lot of attention to itself and sustain heavy damage, and submarines will be instantly revealed as the brightly-painted obstacles are broken free of their chains and bob to the surface. The system is a cheap, low-tech defense that also confounds and confuses sea monsters that try to chase ships into port.

Gladstone

The secret behind the smooth functioning of Escanaba is Gladstone, Northern Gun's off-limits corporate port and supply center. Gladstone keeps outlet towns like Escanaba up and running, funneling equipment to the more public sales and distribution centers. Situated north of Escanaba and unknown to most NG customers, Gladstone is protected from attacks by pirates and sea monsters, and has a substantial Ishpeming naval base located close to the commercial docks.

Every vessel that sails beyond Escanaba must have special clearance and permission from the Ishpeming Navy (the Privateers contracted to protect the Bay and Northern Gun corporate security). **The Gladstone Naval Base** is the nation's largest and most vital military installation, even more important than the strategic HQ at Ishpeming. The defensive ships that protect the trade convoys and fishing fleets are based out of Gladstone, including the *NGS Michigan*, the flagship of Northern Gun's southern fleet. Besides the Xiticix, Lake Superior is a relatively calm front, too cold and remote most of the year for significant pirate activity. That means Gladstone is the anti-piracy headquarters for all of Northern Michigan, home to the courts that try captured pirates and the office that sorts through booty recovered from pirate ships and bases. Privateer companies and land-bound mercenaries are constantly coming and going, delivering prisoners, off-loading stolen goods and receiving repairs on their ships and payments for bounties.

Gladstone is a naval fortress known to few outside the Ishpeming Military Contract Network. Most people think Escanaba is the military center as well as a major commercial port. They have no idea of the scale of the NG Navy and its forces at Gladstone.

Aaron Leonard, Gladstone Base Commander, Quick Stats: Aaron is a decisive leader who takes no chances and is quick to action. He is well liked and respected by his men. **Alignment:** Principled. **Attributes:** I.Q. 17, M.E. 20, M.A. 15, P.S. 20, P.P. 15, P.E. 13, P.B. 12, Spd 11. **Experience:** 11th level Naval Military Specialist.

John Santa Barbara, Captain of the Fast Response Fleet, Quick Stats: John is a something of a swashbuckling sea captain with the swagger of a Pirate. In fact, there are rumors that he used to be a Pirate out of Montreal before he changed his ways. He leads one of the most notorious Gladstone naval forces that responds to threats and suspicious ships in Escanaba waters and chases down brigands. He and Commander Leonard do not tolerate Pirates, Raiders, Slavers or Smugglers. And neither man can be bribed or manipulated. **Alignment:** Scrupulous. **Attributes:** I.Q. 17, M.E. 20, M.A. 15, P.S. 20, P.P. 15, P.E. 13, P.B. 12, Spd 11. **Experience:** 9th level CS Nautical Commando Special-

ist. Yes, he is ex-Coalition, but born and raised in Michigan and 100% loyal to NG and Ishpeming.

Stone Island

Once part of the peninsula splitting the Big and Little Bays de Noc, Stone Island was separated from the mainland during the tectonic upheavals of the Great Cataclysm. It is now the first thing that customers and visitors see on their voyage to Escanaba, a thickly forested island that shelters the port city from the worst of the Great Lakes' storms.

Other than automated lighthouses on its northern and southern points, Stone Island is uninhabited. Northern Gun R&D sometimes tests out new products in the island's interior, where there are no prying eyes, but mainly it serves as a buffer to keep smugglers and pirates away from Escanaba and Gladstone. Regular patrols, along with cameras and listening devices on shore, alert the authorities in MercBay if anyone sets up camp, and NG would much rather intercept criminals and threats on Stone Island than encourage them to try to land secretly on the mainland.

The Fayette Islands, to the north and west, are officially part of the Manistique Imperium, more than a dozen small islands that were also formed during the Coming of the Rifts. The Imperium does not have the resources necessary to effectively patrol them, however, and while naval forces from Ishpeming lend a hand, smugglers and pirates are always being chased out of the area.

Menominee, “Pirate's Point”

Menominee is the southernmost point within the Republic of Ishpeming and the sales outlet located furthest south. The city is deep within **Green Bay**, and has become a magnet for pirates, raiders, criminals and many people of dubious reputation and those in trouble with the law looking to resupply, do some shopping or sell their ill-gotten gains, as well as the privateers who try to police the bay.

The city is a contradiction in many ways. It is a frontier post with a dark underside. Far removed from the rest of the Ishpeming Republic, but connected directly to **Escanaba** by the *Escanaba Road*, it is a backwater community, yet a profitable sales site. Its customers are mainly pirates, criminals, mercenaries and other roughnecks and fugitives. All the pirates and brigands who come to town pretend to be privateers, legitimate ship captains or adventurer-types. One would think that every ship captain on the Great Lakes must be in Menominee should they walk through and try to introduce themselves. Many of these people are on the *CS* and/or *Northern Gun's Wanted List* (or will be soon), and are only able to shop if they are discreet, make sizable orders or don't hang around town for very long. Sometimes the LPO (Loss Prevention Office) will stakeout sales and special offers, baiting pirates and cutthroats with prices they simply cannot resist.

Menominee is also a sign of salvation for those staggering in from the Wisconsin, Minnesota and Canadian wilderness. Tolkeen refugees, fur trappers, Wilderness Scouts and farmers trying to scrape by in the hostile woodlands all come through Menominee. As do adventurers, practitioners of magic, D-Bees, Rogue Dog Boys, and Cyber-Knights. For those with a past, wanted by

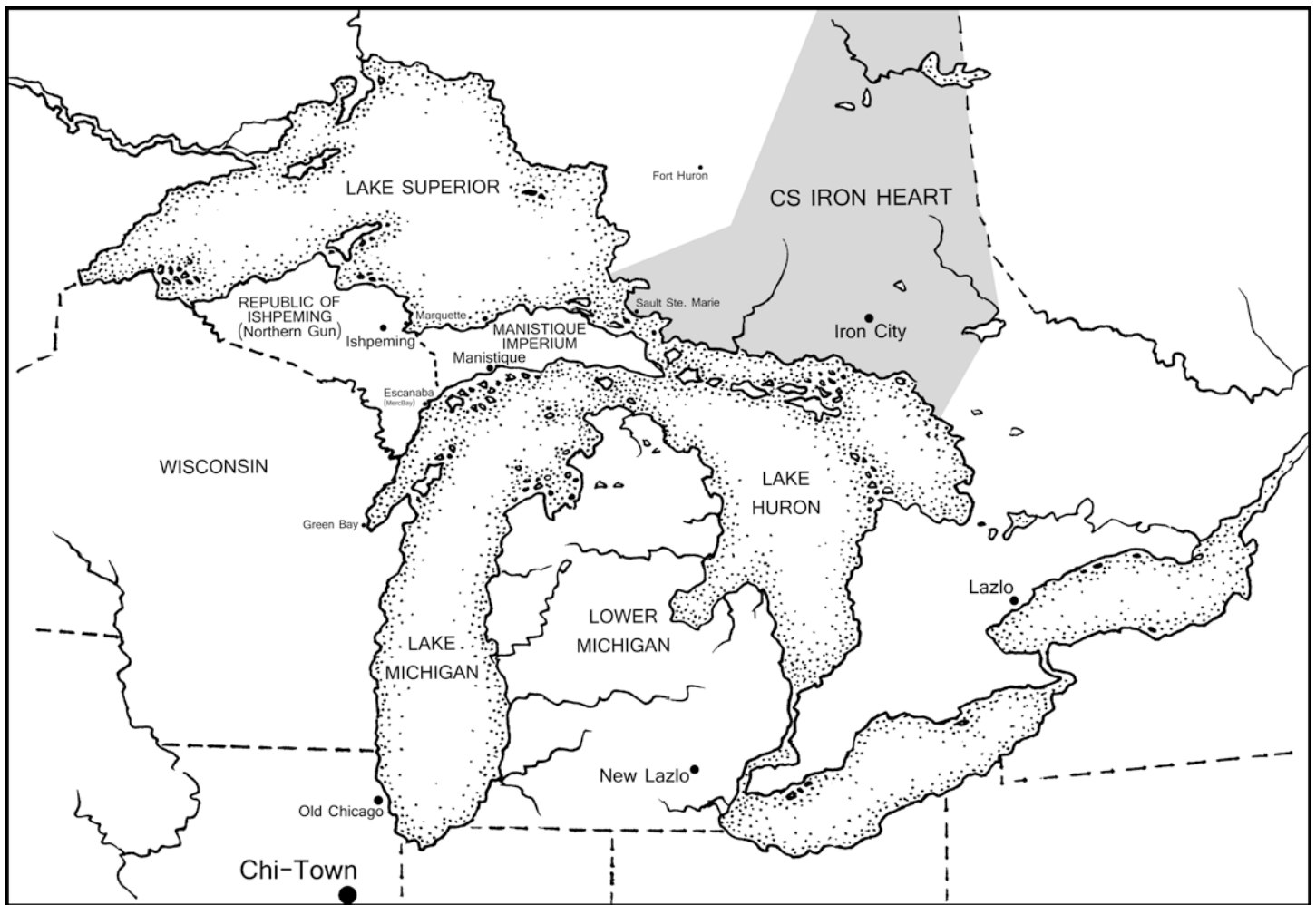

the law, looked down upon by polite society (or the CS), as well as those who'd prefer to stay away from the limelight of the big cities, Menominee is a place to resupply and enjoy the benefits of "civilization" without getting too close to "real civilization." Wild Psi-Stalkers come and go as well, and sometimes *Simvan Monster Riders* can be seen at the edge of town as they wait for D-Bee or human allies to make purchases for them or toss on a hooded cloak and attempt to go into town themselves.

Menominee is much less discriminating about D-Bees and outlaws than the rest of Ishpeming, and many D-Bees walk the streets openly without fear. The local LPO (Loss Prevention Office) is plenty busy dealing with the pirates and criminal element that frequent the city, and the distance from the Coalition States means there is little or no pressure to change things or put on a human-friendly face.

The mayor, the magistrate, and what passes for the law in town are all in the pocket of several prominent pirate captains and will take bribes for almost anything from anybody if the money is good enough. Still, they somehow manage to keep the peace and maintain the city.

Iscerus, Local Hero, Quick Stats: A resident Psi-Stalker who serves as liaison for several Wild Psi-Stalker tribes active in the area. He is also a known hero with connections to CyberKnights, some prominent mercenary companies, and heroes at Lazlo. Some even whisper that he once traveled with and defended *Erin Tarn*. Iscerus enjoys the Wild West feel of Menominee and he stands up against bullies and bad guys, especially those who threaten Psi-Stalkers, D-Bees and children. **Alignment:**

Scrupulous. **Attributes:** I.Q. 14, M.E. 22, M.A. 11, P.S. 19, P.P. 22, P.E. 21, P.B. 9, Spd 24. **Experience:** 10th level Wild Psi-Stalker. **Psionics:** I.S.P.: 169. All standard Psi-Stalker abilities and bonuses, plus Intuitive Combat (10), Meditation (0), Mind Block (4), Sense Evil (2), Sense Magic (3), Sixth Sense (2), and Telepathy (4).

Allan "ZeroArmor" Randall, Local Hero, Quick Stats: ZeroArmor is a human Warlock who never wears body armor of any kind. A magic medallion is said to make ZeroArmor a Mega-Damage being. He is the best friend of Iscerus and is often at his side, especially when protecting the innocent. Rumors abound about this guy and his medallion, but nobody has any answers about this enigmatic hero, who is the strong silent type. **Alignment:** Unprincipled. **Attributes:** I.Q. 23, M.E. 23, M.A. 19, P.S. 21 (Supernatural), P.P. 18, P.E. 26, P.B. 24, Spd 58 (40 mph/64 km). **Experience:** 7th level Snow Lizard Dragon Hatchling, posing as a human Water Warlock. **M.D.C.:** 370.

Menominee Air Depot

As the most southerly of Northern Gun's holdings, Menominee is a natural choice as a departure point for cargo flights. A large air depot has been built outside the city for just this purpose. Broadwing cargo planes and smaller bushplanes are constantly coming and going, delivering supplies to mercenary groups and military forces out in the field. Sometimes they are taking critical replacement stock to important sales outlets like MercTown or Arzno, or to civilian stores within the Coalition. Secretive

flights to supposedly “off-limits” customers like *Tolkeen resistance groups* and *Wisconsin pirates* are also conducted out of Menominee to keep them quiet. For while the Coalition States has people who monitor the extremely busy and popular port of Escanaba, Menominee is under their radar, dismissed as a two-bit flea trap where a Coalition presence would be instantly noticed. They have deployed a few intelligence agents to Menominee in the past, but both the criminal and corporate social circles in the city are very close-knit and difficult to infiltrate.

The air depot is an independent NG operation located outside of the city to keep it away from pirates, hijackers and anyone nosy enough to come poking around. Security forces keep watch for several miles around the depot itself and the runways and main storage areas are well protected behind Mega-Damage walls and fences.

Inside the defenses is a regional hub the likes of which are difficult to find on Rifts Earth. Runway after runway connects to hangars full of NG aircraft and warehouses full of products ready to be shipped. While the Xiticix Hivelands, Coalition territory and Tolkeen no-fly-zone all restrict the areas the planes can travel, they still deliver to customers and NG outlets within Wisconsin, Michigan, Ohio and Indiana, plus special runs to clients such as MercTown and Arzno. Airstrips located at Escanaba and MercTown make deliveries to locales further east, south and west, such as the Pecos Empire, El Paso and even Fort Reid in Mexico. **Note:** The city of Ishpeming has its own airstrip and distribution hub, both within the city and found at Fort Sawyer, that cover clients in Canada.

Jeff Schuler, Air Depot Director, Quick Stats: Director Schuler is a no-nonsense boss who oversees all operations of the Air Depot like a general commanding his troops. He is well liked and respected by his men. **Alignment:** Scrupulous and incorruptible. **Attributes:** I.Q. 15, M.E. 19, M.A. 21, P.S. 10, P.P. 9, P.E. 14, P.B. 13, Spd 12. **Experience:** Equivalent of an 11th level CS Technical Officer, specializing in communications.

The Wisconsin Border

The line that separates the Republic of Ishpeming from the wildlands beyond it is based on the old Michigan/Wisconsin border. The arrangement of the Upper Peninsula is a fluke of pre-Rifts politics. The U.P. was given to Michigan as a kind of consolation prize after Michigan and Ohio almost went to war over possession of the city of Toledo.

As Northern Gun grew and asserted its dominance over Ishpeming and the western U.P., its border formed somewhat naturally along the old roads and markings that had been left behind. Pre-Rifts maps clearly showed the border between the two states of the old American Empire, and it was easier to simply follow their guide than to resurvey a new border over miles and miles of monster infested woods.

There are a string of forts and small towns along the border, but most of it is monitored only by infrequent mercenary patrols from the City of Northern Gun. The local mercs use robots and power armor to cover more ground, and the general lack of civili-

zation in Wisconsin, whether human or alien, means there are few organized threats that the border patrol must deal with. Monsters that cross over from the forests of Wisconsin are the main threat.

The Menominee & Montreal Rivers

Most of the Republic of Ishpeming’s border with the old State of Wisconsin is defined by the *Menominee River*. The *Montreal River* is part of the northern border, emptying into Lake Superior. There is also a 40 mile (64 km) stretch between them that extends between the **Ironwood and Iron River border forts**, an open area with no clear physical feature to define its boundaries. The rivers represent the edge of civilization, and one can find farms and small villages to the north and east, and pristine wilderness to the south and west. Barges carrying timber and ore cruise up and down the two rivers, heading back and forth between border outposts, *Menominee* and *Iron Bay*. A half-dozen Harbormaster patrol boats are also docked at Menominee and take turns cruising up and down the Menominee River monitoring the border and responding to calls for assistance or reports of supernatural activity. They will stop at the outposts, mining camps and docking facilities along the river, dispatching parties of marines inland to observe and intercept threats.

Charles Viaud, Menominee River Patrol Captain, Quick Stats: Captain Viaud manages all NG river patrols in the area. He makes do with the meager forces given him and keeps petitioning NG to increase the size and number of patrols. He is a resourceful leader and serious about security along these rivers. **Alignment:** Scrupulous. **Attributes:** I.Q. 14, M.E. 12, M.A. 13, P.S. 21, P.P. 17, P.E. 12, P.B. 14, Spd 19. **Experience:** 9th level Merchant Marine.

Mangels, Quick-Flex Alien Scout for Hire, Quick Stats: This fun-loving character seems to take everything in stride, and has a good sense of humor. However, when stuff hits the fan, he is deadly serious and as crack-shot as any Gunslinger from the New West. He knows the river region almost as well as the local Psi-Stalkers, and offers his services as a scout or bodyguard. **Alignment:** Unprincipled. **Attributes:** I.Q. 11, M.E. 13, M.A. 10, P.S. 12, P.P. 22, P.E. 14, P.B. 8, Spd 38. **Experience:** 10th level Wilderness Scout with the notable skills of W.P. Handguns, W.P. Quick Draw, W.P. Knife, Tracking (people), Track and Trap Animals, Land Navigation, Hunting, Boat: Paddle Types, Boat: Sail Type and various Wilderness skills and others.

The Iron Chain

One of the reasons Northern Gun can manufacture such a huge volume of machines and equipment is its unrestricted access to iron. Iron is used to make steel, vital in modern manufacturing, and ferrous (iron) compounds and alloys are the base for Northern Gun’s version of Mega-Damage armor. By some stroke of luck, three of North America’s six large concentrations of iron deposits are found within or adjacent to the Republic of Ishpeming. The *Marquette range* is safely inside the country’s borders, while the *Menominee* and *Gogebic ranges* overlap the old borders of Michigan and Wisconsin. The Marquette range is home to extensive mining operations, but the future of Northern Gun is found along its western border.

Many of the towns that sprang up during the 19th Century included “iron” in their name. Iron Mountain, Iron River and Ironwood, along with Menominee and the post-Rifts Iron Bay, form the “**Iron Chain**” that protects Ishpeming’s border. The three forts that are part of the chain are all located within rich iron-mining country and the ports at Menominee and Iron Bay provide access to the rest of the nation by sea.

In addition to its sales to pirates, its strategic position as a border fort and its access to Lake Michigan, Menominee is also the hub of the western iron industry in Ishpeming. The Marquette range produces whatever it can, and all of its output goes right to the factories around Ishpeming. The western ranges, however, are broad and untapped in many locations, and small, independent mines, test digs and survey camps are located all over the border area, from Lake Gogebic west, right into Wisconsin. Rivers are often the only established travel routes, and barges loaded with iron float down them towards Menominee before being shipped north to Escanaba on freighters or railcars. And while capturing shipments of iron ore is a bit dry and boring for most pirates, taking the freighters that carry it and ransoming the cargo, the vessel and the crew back to the shipping company that sent them is common practice.

Iron Mountain

Located about 30 miles (48 km) northwest of Menominee, Iron Mountain is a small crossroads situated within a stretch of thick forest. The city is bordered to the south and west by the Menominee River, and connects to a decent road that runs north all the way to Ishpeming. It is considered the main outlet for goods that move along the river to travel inland, intended for Ishpeming and the capital region. And while it may be more difficult to move shipments of iron ore and timber along the road than by ship from Menominee or Iron Bay, there are no pirate attacks deep inland, and the region is too remote even for most bandits and highway-men. The road is also regularly swept by one of several mercenary companies or patrolled by heavily-armed Loss Prevention Officers disguised as simple farmers and travelers.

Captain John Polack, LPO Assigned to Iron Mountain, Quick Stats: Polack requested this post because he has grown tired of city life and prefers the outdoors. He’d consider moving to the country if not for his wife and family living in Northern Gun. **Alignment:** Scrupulous. **Attributes:** I.Q. 14, M.E. 10, M.A. 12, P.S. 21, P.P. 19, P.E. 12, P.B. 15, Spd 18. **Experience:** 8th level Military Specialist.

Iron River

Iron River is found far within the Upper Peninsula, sited where the Menominee River ends and the land border between it and the Montreal River begins. It is the last stop along the Menominee River, and as far inland as one can go from Pirate’s Point without leaving their boat behind. Iron River is a small fort and town, and sees fewer travelers, traders and farmers than the other portions of the Iron Chain. It is relatively cut off from the rest of the nation, as well. Following the river south down to Iron Mountain is the quickest way out, as the only other options are to trudge inland through many miles of untamed woodlands and mining country or head west along the land border to try and reach Ironwood.

Colonel James Eric Ritchie, Fort Commander, Quick Stats: Colonel Ritchie is an NG company man who accepts any assignment given to him. He made the rank of Colonel at a young age and sees this backwoods post as a stepping stone to a better future. As a result, he runs his command by the book and keeps the men battle-ready. **Alignment:** Principled. **Attributes:** I.Q. 20, M.E. 11, M.A. 10, P.S. 24, P.P. 14, P.E. 14, P.B. 13, Spd 14. **Experience:** 7th level Mercenary Soldier.

Ironwood

Ironwood is the northernmost inland border fort and town protecting the Wisconsin border. It is the northern gateway to Ishpeming, and sits along one of the only reliable roads that run to Ontonagon and the center of the country. Beyond the city is *Lake Gogebic*, a long, north-south running lake that acts as a natural boundary between the border zone and the nation’s interior.

Ironwood is also a hub for goods heading north to the port at *Iron Bay*. While the majority of commerce from Ishpeming’s western farms, logging operations and mines flows through Menominee, Iron Bay is the destination for those who cannot reach the Menominee River and easy access to the city that shares its name.

Captain Wade Rohl, Fort Commander, Quick Stats: Captain Rohl is a Gunfighter from the Pecos Empire, where he also worked as a saloon keeper and did a stint as a sheriff. He decided to give up the Wild West and try life in a more civilized part of the world. He always liked NG products so he came to Ishpeming. He is a good leader, respected by the mercs who serve at the fort. **Alignment:** Scrupulous. **Attributes:** I.Q. 14, M.E. 13, M.A. 15, P.S. 17, P.P. 21, P.E. 12, P.B. 14, Spd 12. **Experience:** 9th level Wilderness Scout.

Iron Bay

Iron Bay is the only part of the Iron Chain that is not based on the site of a pre-Rifts city. Located on *Oronto Bay* where the Montreal River reaches *Lake Superior*, it is a small mining town and shipping center, far north and close enough to the Xiticix Hivelands that many outsiders don’t even know of its existence. This anonymity and the presence of the Xiticix help keep pirates away, along with Task Force X based out of nearby Ontonagon.

The port is small and relatively defenseless, its only protectors a tiny detachment from a larger mercenary company that has scored arguably the least-desirable job on the Ishpeming Military Contract Network. The weather is terrible, the pay no better than any other assignment (and worse than most), and the threat of an unpredictable pirate attack or sudden Xiticix swarm means there is a real chance of the city being wiped out before more help can arrive from the east. Should something of that magnitude occur, the population is ready to evacuate by boat to Ontonagon and inland to Ironwood.

Colonel Erik Stewart, Fort Commander, Quick Stats: Colonel Stewart was assigned to Iron River after a falling out with *General Timothy Letts* over the Xiticix debate. To make a long story short, the last words of General Letts were, “If you’re so concerned about the damn bugs, you can sit in the woods and count them.” Indeed, Colonel Stewart has launched his own, private study of the Xiticix using the troops assigned to him. This includes experimentation in different approaches to fighting the

Xiticix. His concern over the Xiticix has become something of an obsession. **Alignment:** Principled. **Attributes:** I.Q. 17, M.E. 9, M.A. 10, P.S. 20, P.P. 18, P.E. 17, P.B. 9, Spd 23. **Experience:** 10th level Mercenary Soldier with a bionic right eye, jaw, arm and leg resulting from a battle with Xiticix midway in his career.

Porcupine Mountains

Located along the Lake Superior coast are the low-lying Porcupine Mountains. While not terribly tall (the loftiest peak is only 2,000 feet/610 m), the “mountains” are rough, mixed terrain, difficult even for large robots to traverse and impassable by most wheeled vehicles. During the winter, the mountains are subject to massive amounts of lake-effect snow, making them even more forbidding and impassible. And while they are situated far enough away from the border that they don’t really act as a buffer, they do protect the vital *port of Ontonagon’s western approach*. And combined with *Lake Gogebic*, they make up a secondary defensive position should the border ever be threatened by an outside force like the Xiticix.

The mountains are rich with wildlife and home to some of the Republic of Ishpeming’s finest stands of old growth lumber. Limited logging operations are underway during spring and summer, but the entire area shuts down in early autumn and goes to sleep during winter and doesn’t wake up for months. The Upper Peninsula’s only set of prominent ley lines run along the coast and through the Porcupines and light up the snowy mountains with their magic iridescence.

In addition to earthly creatures, the dense mountains also shelter strange beings from the Rifts that have crawled up out of the sea. There is no telling what might be living within the mountain range, and logging operations are conducted at the lumberjacks’ own risk.

A group of freelance heroes and adventurers calling themselves the Iron Mountain Defense Force has been patrolling the mountains, protecting the locals and weeding out the most dangerous monsters for years. They have a great reputation, so Northern Gun hired them to be their official representatives and protectors to the region.

Sir Eric Canapini, Iron Mountain Defense Force, Quick Stats: Sir Eric is a Cyber-Knight and a self-styled Monster Hunter. He commands a force of elite warriors who are skilled trackers, soldiers and monster slayers. **Alignment:** Scrupulous. **Attributes:** I.Q. 14, M.E. 14, M.A. 17, P.S. 20, P.P. 21, P.E. 17, P.B. 11, Spd 14. **Experience:** 8th level Cyber-Knight.

Lieutenant Doug Buhlman, Iron Mountain Defense Force, Quick Stats: Lt. Buhlman is a full conversion cyborg thanks to a raid by Brodkil, so he has a special hate for monsters, especially demons. **Alignment:** Anarchist. **Attributes:** I.Q. 12, M.E. 14, M.A. 10, P.S. 32 (Robot), P.P. 22, P.E. 12, P.B. 8, Spd 176 (120 mph/192 km). **Experience:** 8th level Combat Cyborg. **Note:** His favorite weapon is a magic Rune sword he took from a Horune Pirate Captain. The weapon does 4D6 M.D., double damage to demons(!), and spits lightning bolts (3D6 each, 500 foot/152 m range). The sword speaks to the cyborg via telepathy and enjoys killing. As of late, the sword has been giving Doug nightmares about demons invading the Americas.

Sergeant Torrey Jones, Iron Mountain Defense Force, Quick Stats: Sgt. Jones comes from a long line of heroes he can trace back to the latter half of the Two Hundred Years Dark Age.

If Torrey wasn’t a Glitter Boy with a legacy of family heroics, he’d probably be a Cyber-Knight. **Alignment:** Scrupulous. **Attributes:** I.Q. 12, M.E. 15, M.A. 20, P.S. 18, P.P. 21, P.E. 11, P.B. 10, Spd 9. **Experience:** 7th level Glitter Boy Pilot.

Hendrik Harterich, Ley Line Rifter, Iron Mountain Defense Force, Quick Stats: Hendrik is a visitor from the New German Republic where he had spent time fighting Gargoyles and Brodkil. Something of a veteran monster slayer, he met the Iron Mountain Defense Force, liked the members of the group and joined them. He is a grounded, empathetic individual with innate wisdom and a great appreciation of life. His presence brings stability and reason to the group. **Alignment:** Scrupulous. **Attributes:** I.Q. 20, M.E. 14, M.A. 22, P.S. 12, P.P. 11, P.E. 12, P.B. 12, Spd 10. **Experience:** 9th level Ley Line Rifter. **Some Skills of Note:** Lore: Demons & Monsters, Lore: D-Bees, Lore: Faeries & Creatures of Magic, Lore: Magic, Lore: Vampires, and Philosophy.

Connor A. Brown, Mind Melter, Iron Mountain Defense Force, Quick Stats: Connor is a young lad with the gifts of Master Psionic abilities. He aspires to be a hero and has a tender heart and generous spirit. **Alignment:** Scrupulous. **Attributes:** I.Q. 15, M.E. 22, M.A. 17, P.S. 10, P.P. 13, P.E. 10, P.B. 10, Spd 9. **Experience:** 5th level Mind Melter with incredible potential.

Stanley Woo, Ninja Cyborg, Iron Mountain Defense Force, Quick Stats: Stan is a Ninja Cyborg from Japan! He has four arms, bionic weapons, fire breath, cybernetic language translator, and other bionics and cybernetics (see page 88 of **World Book 8: Rifts® Japan** for details). *And no memory.* Stan has no idea how he came to this part of the world or his purpose. He vaguely remembers fighting demons, a Rift opening and then . . . nothing. He believes he is a hero and that Fate has brought him to this land for a reason. When Fate is done with him, he will find his way home. **Alignment:** Anarchist. **Attributes:** I.Q. 13, M.E. 14, M.A. 10, P.S. 30 (Robot), P.P. 24, P.E. 12, P.B. 8, Spd 176 (120 mph/192 km). **M.D.C.:** 280. **Experience:** 7th level Ninja Cyborg.

Other Notable Members of the Iron Mountain Defense Force:

Shepard Williams – 9th level Wilderness Scout; Scrupulous.

Chris Altobelli – 7th Level Headhunter; Scrupulous.

Erich Eisenmenger – 8th level Mercenary Soldier, Scrupulous.

David Rogers – 6th level Juicer; Unprincipled.

Thaddeus Ryker – 8th level ex-CS SAMAS Pilot; Unprincipled.

Steven Yeung – 7th level Mystic; Scrupulous.

Dave Simmens – 7th level Techno-Wizard; Scrupulous.

Jason McQuain – 8th level Cyber-Doc; Scrupulous.

Rob Daily – 6th level Body Doc; Principled. A Major Psychic with 57 I.S.P. and the healing powers of Bio-Regeneration (6), Deaden Pain (4), Exorcism (10), Healing Touch (6), Increase Healing (10), Meditation (0), Psychic Diagnosis (4) and Psychic Purification (8).

Brian Keen, Iron Fields Councilor

In the Dark Age, before Northern Gun encompassed all of Ishpeming, there was a proto-state emerging in the southwest corner of the proposed kingdom. Based out of Menominee, the short-lived collection of settlements included *Menominee, Iron Mountain, Iron River* and *Crystal Falls*, most of what would eventually

become the western border of the Ishpeming Republic. Near the end of the Two Hundred Years Dark Age, this league of cities was dissolved and absorbed into a Northern Gun that was asserting its power and dominance. They were already close allies with Ishpeming and dependent upon its manufactured goods, so the choice was an easy one.

Brian Keen is descended from the powerful families that used to control the cities of southwestern Ishpeming. In many ways, he is the last vestige of that world, as the western iron fields and border have been increasingly placed under the control of overseers from Ishpeming. Mercenary contractors have replaced the local militias, and the notoriety of Northern Gun has eclipsed the reputation of any individual city. Keen is unconcerned; he was born a non-contract employee of Northern Gun and the current arrangement is the only world he has ever known. All Keen can be sure of is that he has been given special power and privilege and seeks to use them to further his own interests and those of his community.

The Keen family is a major power player within Northern Gun and has a long history of Glitter Boy heroes who defended the land throughout the Two Hundred Years Dark Age. Brian did a little adventuring himself in his youth and owns a suit of Glitter Boy armor passed on from generation to generation. Next to the deposed King of Ishpeming, the *Keen family* is the closest thing to royalty the corporate-state knows. No Northern Gun offices are passed down through heredity, and rarely are dynasties able to spring up within the company. The Keens had the power before they were part of Northern Gun, and still conduct themselves with an air of aristocracy. Brian Keen is often chosen to meet with representatives of the Manistique royal family, a role for which his high-breeding and sense of self-importance prepares him perfectly.

Brian Keen, Iron Fields Councilor, Quick Stats: A personable and intelligent politician who is truly concerned about the welfare of his constituents and the Republic. **Alignment:** Unprincipled. **Attributes:** I.Q. 15, M.E. 12, M.A. 19, P.S. 14, P.P. 19, P.E. 15, P.B. 12, Spd 11. **Level of Experience:** 4th level Glitter Boy Pilot and the equivalent of an 8th level politician/diplomat.

The Michigan Lower Peninsula

Before the Coming of the Rifts, Michigan's Lower Peninsula was the center of civilization and the Upper Peninsula was a lightly-populated frontier. Now things have changed completely, and the Lower Peninsula is covered in forest and has no cities to compare to the great technological empire of the U.P. There is one exception, New Lazlo, a city of magic built on the ruins of Ann Arbor. But while New Lazlo does import Northern Gun products, there are no land routes that connect the two and politically, they are quite distant. Ships carrying NG products (though none that officially fly a Northern Gun flag) regularly dock at New Lazlo's port south of the ruins of Detroit. NG is happy to accept their business, but now does so in secret and through third parties thanks to the community being labeled Enemies of the Coalition States.

Missions into Lower Michigan and Wisconsin. Northern Gun is an island of security and prosperity in the midst of a vast wilderness all around it. It may connect with the Manistique Imperium, but reaching any other nation involves a voyage on the Great Lakes or a perilous journey through Michigan, Wisconsin

or Canada. Official expeditions to the Michigan mainland are very rare. Strange as it may sound, air travel – though being attempted with increasing frequency – is even more dangerous. Brodkil, bandits, pirates and others are all too happy to shoot down an aircraft and go to the crash site to salvage whatever they can. Likewise, Xiticix, dragons and other flying monsters (not to mention Coalition forces) tend to attack aircraft and flyers larger than a van and airborne more than a thousand feet or so. The inhabitants of the forests of Southern Michigan are virtually the same as Green Bay, with more small bands and tiny communities of pirates, separatists, bandits, D-Bees, Brodkil, farmers and homesteaders making their home there.

Green Bay

Green Bay is full of smaller bays and inlets, as well as a few notable rivers. The bay and the peninsula that forms it are both a hotbed of pirate activity. This could be because of Northern Gun or in spite of it, as pirates are occasionally hunted down by Ishpeming's military contractors but would never be able to engage in their "trade" without Northern Gun's weapons.

Green Bay is somewhat isolated from the rest of Lake Michigan by the Door Peninsula and the islands that extend away from it. And while the bay itself is much more open to the Great Lakes than in Pre-Rifts times, it still offers some shelter from storms to ships within its waters and has been carefully marked and charted by the Northern Gun.

The Republic of Ishpeming's southern coast is all technically within Green Bay. The Door Peninsula extending from Wisconsin and the Fayette Islands reaching out from southern Manistique project into Lake Michigan to create the bay. The northern part of the bay is one of the major shipping channels in North America and the main way most Northern Gun products reach their customers. The southern part is infested with pirates and sea monsters in equal measure, and is only halfheartedly patrolled by Northern Gun and its military contractors.

The protrusion of land that extends northeast from Wisconsin and creates Green Bay is known as the **Door Peninsula**. Sturgeon Bay, once a Golden Age Wisconsin city, now sits on the Sturgeon Channel, cutting the peninsula in half and providing a secondary route for pirates to filter back and forth from Lake Michigan, further south and away from the radar systems and patrol boats that guard the shipping lanes leading to Escanaba.

The pre-Rifts **City of Green Bay** was decimated by the Great Cataclysm to the point that, except for the battered ruins of a half dozen Mega-Damage buildings still standing, and jutting up from the forest that has reclaimed the land, you would never guess the region was ever populated. Today, the coast is dotted by a few tiny fishing villages. The interior is home to the occasional hunting lodge, homesteader and farm. Small, nomadic tribes of Native Americans, Psi-Stalkers and D-Bees also visit the area to hunt and pitch temporary camps, as do pirates and adventurers, but none establish permanent communities or buildings. Travelers who stumble across a pirate camp or group of bandits could find themselves in trouble fast. Fury Beetles and other monsters abound in these woods. Brodkil, Black Faeries and other dangerous creatures are also known in this part of the country; the former looking for weapons and bionics to steal. Ghosts and Poltergeists are also said to wander the woods of Green Bay.

Plum Island Region

Green Bay Graveyard and the *Porte des Morts*

Formerly located north of the Door Peninsula, **Plum Island** sank beneath the waves when the Rifts appeared and rocked the Earth. Even when it still stood, treacherous waters around it made the area into a *ship graveyard*. When the French originally charted the Great Lakes, they took note of the dangerous channel that passed around the island and named it **Porte des Morts**, the “Door of the Dead.” And with Plum Island itself now lurking just beneath the surface, the area has only become more treacherous. More than 250 pre-Rifts shipwrecks litter the lake in the immediate vicinity, as well as dozens of vessels that have gone down in the years since the Great Cataclysm. Pirates, merchants, privateers, Ishpeming naval forces, D-Bee ships and even Coalition patrols have all sunk trying to navigate the area, and the local lake-bed is rich in salvageable goods and submerged treasures. This patch is known as the Green Bay Graveyard, and is regularly swept for valuables by pirates equipped with submersibles, power armor, or ocean magic to plumb its depths.

With so many tragic deaths, the **Green Bay Graveyard** is home to many Haunting Entities and Poltergeists, as well as the occasional, more deadly Entity, such as Syphons, Tectonic and Possessing Entities. Sailors on ships passing through claim to hear the wails and cries of the dead and sometimes report seeing apparitions below the waves. Those who linger in the haunted waters are the ones likely to have their ships visited by ghosts and more dangerous Entities, but it is those who dive down into the water for salvage or exploration who are in the greatest peril. In addition to ghosts and Entities, Cadborosaurus, giant squid, and a litany of other regional monsters are also present in the water and air and lurking on shore. **Note:** The location where the pre-Rifts city of Green Bay once stood is also said to be haunted, but nothing like the Green Bay Graveyard beyond the shore.

Washington Island

Washington Island is the northernmost island extending from the Door Peninsula, shrunken from its Pre-Rifts size due to erosion and changing water levels. Its exposed location outside Green Bay makes it a risky stop for pirates, because their vessels can be seen from the mainland and from a distance out on the lake as well as from the air. Still, the island is often used as a place to hole-up during rough weather by pirates and raiders. The island and surrounding waters contain the ruins of several pre-Rifts towns, and an old airport can be found on shore. The island is uninhabited – at least by humans and D-Bees – and has been reclaimed by nature. That means even the ruins are covered in vegetation and light forest.

The broken coastline is full of popular landing spots for pirates, smugglers, and other brigands, but such miscreants can be found anywhere on the islands of Green Bay. Most set anchor and come ashore to wait out foul weather, to sort through loot and even hide valuables in the ruins and secret hiding places. Likewise, many hide supply caches on the island and stop to resupply, while many others meet with Black Marketeers and smugglers to trade stolen goods for weapons, supplies and money.

The ruins of **the airport** and what’s left of the town of Washington are in the northwest portion of the island. While it too is sometimes used by pirates, criminals and fugitives, it is a known

landing site and way-point for Ishpeming naval patrols, air patrols and privateers hired by Northern Gun to hunt and chase away sea serpents, pirates and other brigands whose criminal enterprises have gotten out of hand in the area. To this end, a part of the airfield has been cleared of debris and forest for use by NG flyers and there are even a few hidden, underground fuel tanks for refueling aircraft as well as three hangars and two small buildings suitable for shelter and pitching camp. Most of the time, however, the old airport is abandoned, you simply don’t know when NG hired mercs and privateers are going to show up. Fugitives and blackguards who tempt fate or unwittingly occupy the airport facilities for days or weeks at a time are likely to be discovered and taken down when an NG patrol arrives. It is interesting to note that many Black Marketeers and smugglers do, indeed, use the Washington Island airfield to drop off goods to criminal clients and carry away illegal cargo and stolen goods, but the smart ones never stay longer than 1D4 hours, and vacate at the first sign of an NG patrol off in the distance and the first hint of trouble. NG air and lake patrols know this, but only crack down when piracy and hijacking get out of control and when they have need of the facility for their own purposes.

Lake Winnebago

If one dares to sail among the ruins of Green Bay, the *Fox River* leads south through the city and into Lake Winnebago. Roughly 30 miles north to south and about 10 miles wide (48x16 km), the lake is quite substantial and separated by the river from Green Bay and the Great Lakes. While it is extremely shallow, only 15-20 feet (4.6 to 6.1 m) deep, the lake can be navigated by small watercraft, hydrofoils, barges and any vessel with a shallow draft.

In addition to providing shelter for transient pirates, privateers and adventurers traveling by water, Lake Winnebago also connects to several inland waterways. The **Fox, Wolf and Waupaca Rivers** lead away from the lake, and eventually connect with **Lake Butte des Morts, Lake Winneconne, Lake Poygan** and hundreds of small lakes, rivers and creeks that weave through Wisconsin. Using this system of waterways, pirates and others can travel more quickly and freely within the Wisconsin wilderness than by land, though they may be reluctant to set ashore and travel far from the protection and mobility of the waterway. The wilds of Wisconsin are full of danger.

The Rest of Wisconsin

Away from the coast, Wisconsin is a no-man’s land covered in forest and filled with wildlife. The Coalition mounts a few patrols into southern Wisconsin, but for the most part, is unwilling to expend the resources necessary to secure the vast territory. The wildlife, monsters, creatures of magic, Xiticix, wilderness people, and presence of magic (ley lines and dimensional Rifts) and the things that regularly come and go via the Rifts, all make Wisconsin a difficult prospect for taming and establishing long-standing communities. The average “life” of a town or village that settles in one permanent location is 6-10 years. Towns and even small kingdoms have come and gone a thousand times over the last three centuries. Wisconsin is marked for eventual annexation by the Coalition States, but is not part of the 20 year plan for Coalition expansion, making it a distant priority.

As far as Northern Gun is concerned, just securing the border with Wisconsin is costly enough, both in funds and human life. There are no plans to actively retake the state, and most of the salvageable pre-Rifts sites (military bases, University of Wisconsin, etc.) were looted generations ago during the Two Hundred Years Dark Age, sometimes by people who would end up as part of Northern Gun. Ishpeming already has all the worthwhile tech that has been dug out of the ground, and sees no desire to attempt to tame a vast wilderness and overextend themselves by widening the potential battle front with the Xiticix. **Note:** Many of the creatures and monsters described in the pages of **Rifts® Sourcebook 4: Coalition Navy** and **Rifts® Canada** inhabit the forests of *Wisconsin, Lower Michigan, Ohio, Minnesota, the Dakotas* and what was once the *Northeastern United States* and *Southern Canada*. Native Americans, Psi-Stalkers and sometimes Simvan also live in and travel through Wisconsin, as do mages, dragons and creatures of magic.

Lake Superior & Northern Ishpeming

Houghton

Houghton is the northernmost actual city in the *Republic of Ishpeming*. Making it one of humanity's most northern outposts in all of America – only Iron Heart and Free Quebec are further north. It is the guardian of the *Keweenaw Peninsula* and *Copper Island*, rich copper mining territory, logging ground and hunting country, separated from the mainland by the *Keweenaw Waterway*, a river course that was expanded by dredging in the 19th Century. Houghton is a trading stop and naval base, and is vitally important to the history of Northern Gun as it was home to *Michigan Technological University* before the Coming of the Rifts. A university whose facilities and information were looted and brought back to Ishpeming during the Two Hundred Years Dark Age.

Michigan Tech was a mining and engineering school, and the equipment and computer files recovered there served as a basis for many early Northern Gun manufacturing projects. Later in the Two Hundred Years Dark Age, when the city was reclaimed by man, the somewhat preserved ruins of the campus served as a kind of central citadel from which the entire city was built around. Now, many years later, Houghton is a fishing and trading port, a naval base that watches over the Keweenaw Waterway, and a hub for logging and copper mining. **The Keweenaw Peninsula** on the other side of the waterway is about as wild and remote as anywhere in the entire Republic, and features only a handful of permanent habitats. Most of the work done on the peninsula is based within Houghton.

The Houghton naval base is a secondary facility that backs up Ontonagon and protects the waterway. Pirates and smugglers take advantage of the remote and untamed nature of the peninsula and use it to land and conduct illegal business. The naval base watches out for such brigands and chases them off. Those who put up too much of a fight are blown out of the water. The Houghton NG Naval Base is part of the chain joined with **Ontonagon** and **Marquette** that keeps the northern coastline relatively well monitored and free of pirates and bandits. They are also prepared for large-scale action by the Xiticix or dimensional raiders from a Rift.

As the gateway to one of the Republic of Ishpeming's small frontiers, Houghton is even more rustic and low-tech than the rest

of the country. It looks more than a bit slapped together and ramshackle, but it also has an exciting “boomtown” feeling. There are few women in town, a great many miners and loggers, and a high-rate of alcohol consumption. A handful of fortunes are made in Houghton by gamblers, prospectors and land speculators, but most find nothing but hard work, low pay and cold, snowy winters. Unlike most of the Republic, literacy is the exception, not the rule, with only a 28% literacy rate.

Dale Gifford, Commander of the Houghton Naval Base, Quick Stats: Commander Gifford is a capable leader with a hate for pirates, especially Horune. Any pirates who don't turn tail and run from his patrols are likely to be destroyed, even if they want to surrender later in the battle. Gifford has no love for Xiticix and distrusts most D-Bees. **Alignment:** Unprincipled. **Attributes:** I.Q. 17, M.E. 11, M.A. 15, P.S. 20, P.P. 14, P.E. 13, P.B. 14, Spd 13. **Experience:** 9th level Sailor.

Michael Pointer, Head of the Houghton Miners' Guild, Quick Stats: Pointer is a rough and tumble man with a good sense of humor and empathy for his workers. He has worked in the mines and knows what type of backbreaking work it is. He is never afraid to take a stand, and is always working to make the mines safer and Houghton a worthwhile community. **Alignment:** Principled. **Attributes:** I.Q. 15, M.E. 14, M.A. 20, P.S. 24, P.P. 11, P.E. 14, P.B. 13, Spd 9. **Experience:** 10th level Vagabond Miner. **Skills of Note:** Basic Mechanics, Excavation, Firefighting, Gambling, Law: General, Literacy: American, Masonry, Mining, Rope Works, and W.P. Heavy M.D. Weapons.

Scott Banzhaf, Businessman and Professional Gambler, Quick Stats: Banzhaf sees himself as part tycoon and part swashbuckler. He is charming, handsome and quick to exploit opportunities. He owns or has a percentage ownership in 20% of the businesses in Houghton and owns all three of its gambling establishments. The jury is still out on whether he is a good guy looking to build Houghton or a carpetbagger looking to make a quick buck. **Alignment:** Anarchist. **Attributes:** I.Q. 19, M.E. 10, M.A. 23, P.S. 12, P.P. 15, P.E. 9, P.B. 21, Spd 10. **Experience:** 9th level Vagabond Businessperson and Gambler. **Skills of Note:** Literacy: American, Cardsharp, Find Contraband, Gambling, Gambling Dirty Tricks, Palming, Seduction, and W.P. Handguns.

Michael Gale, Logging Company Owner, Quick Stats: Gale is another, no-nonsense tough guy who owns and runs the largest logging company in Houghton. It is a family business, but Gale is no weak-willed inheritor of the company. He knows what he is doing, he's very good at it, and he is the kind of boss who is out in the field with his workers. He too wants to see Houghton grow and be recognized as a valued member of the Ishpeming Republic. However, he has little respect for politicians and city people until they have earned it. **Alignment:** Principled. **Attributes:** I.Q. 18, M.E. 14, M.A. 12, P.S. 22, P.P. 15, P.E. 19, P.B. 12, Spd 12. **Experience:** 9th level Vagabond Logger/Businessperson. **Skills of Note:** Boat Building, Carpentry, Climbing, Land Navigation, Literacy: American, Rope Works, Sailing, Swimming, Wilderness Survival, and W.P. Axe.

Stephen McDonald, Houghton Sheriff, Quick Stats: As the Sheriff, McDonald has his hands full with all the hard-working, hard-drinking, rough and tumble types who live in Houghton. Sheriff McDonald has the perfect disposition for handling the wide range of characters in town. Petty crimes like drunken disorderliness, brawls, and damage from both, require the perpetrator to sleep it off in jail and to pay for any damages, and gets him a

swift kick in the pants. There is no criminal record for such small and common offenses. Crimes such as piracy, duels, gunfights, murder, rape, and theft of horses, robots and valuables are treated with extreme prejudice. **Alignment:** Scrupulous. **Attributes:** I.Q. 17, M.E. 19, M.A. 15, P.S. 15, P.P. 21, P.E. 14, P.B. 18, Spd 12. **Experience:** 11th level Sheriff. **Skills of Note:** Basic Math, Firefighting, Gambling, Horsemanship: General, Law: General, Literacy: American, W.P. Handguns, W.P. Energy Pistol, W.P. Energy Rifle, and W.P. Shotgun.

Keweenaw Peninsula & Copper Island

The Keweenaw Peninsula technically encompasses Houghton and a large portion of mainland Ishpeming. The section on the northern side of the Keweenaw Waterway is referred to as **Copper Island**, and, as its name suggests, is home to numerous copper mines. Cut off from the rest of the nation, Copper Island is also rich in uncut stands of trees and logging crews are just now beginning to exploit the old-growth lumber that accumulated during the Two Hundred Years Dark Age.

Camp Copper is the largest permanent settlement on Copper Island. It is located at the northern edge of Torch Lake, and is accessible via the Keweenaw Waterway. Boats move back and forth between Houghton and Camp Copper, carrying miners, ore, lumber and heavy equipment. *Torch Lake* cuts deep into the center of Copper Island, and trails and rough-hewn roads radiate outward from the camp to various mines, docks and logging sites. The camp rests right on the edge of Northern Gun's reach, and Loss Prevention Officers who are sent there to retrieve outlaws must contend with the rough characters they encounter and the shadowy local power structure of mine bosses, landowners and leaders of pirate and bandit gangs.

Matthew Robertson, Mayor of Camp Copper, Quick Stats: The mayor is a tough, cagey, larger-than-life town boss and the local magistrate/judge. He has undisguised contempt for the people and power-base of Northern Gun and always tries to overcharge and cheat them whenever they have dealings. Robertson used to be a mercenary (some say Juicer) before returning home to Houghton (after a successful Juicer detox). He shows no fear to anyone and knows how to handle himself in a fight. **Alignment:** Anarchist. **Attributes:** I.Q. 15, M.E. 12, M.A. 10, P.S. 23, P.P. 17, P.E. 14, P.B. 10, Spd 22. **Experience:** The equivalent of a 9th level Merc Soldier (was a 6th level Juicer before detox). **Skills of Note:** Acrobatics, Climbing, Gambling, Literacy: American (but only at 4th level proficiency), Pilot: Hovercycles, Pilot: Tanks & APCs, Streetwise (Houghton), W.P. Knife, W.P. Energy Pistol, W.P. Energy Rifle and W.P. Heavy M.D. Weapons.

Anthony Barrios, Mine Owner, Quick Stats: Barrios is the owner of one of the largest mining companies. Unknown to NG and outsiders, a few of his foremen are Earth Warlocks who discreetly use Earth Elemental magic. **Alignment:** Unprincipled. **Attributes:** I.Q. 14, M.E. 13, M.A. 12, P.S. 15, P.P. 12, P.E. 17, P.B. 14, Spd 13. **Experience:** 10th level Vagabond Miner. **Skills of Note:** Basic Mechanics, Excavation, Firefighting, Law: General, Literacy: American, Masonry, Mining, Rope Works, and W.P. Heavy M.D. Weapons.

Brent Casavant, Saloon Owner, Quick Stats: Casavant runs and owns a large saloon popular among adventurers, mercs, sailors and pirates. He is also a Black Market Expediter and many of his "associates" at the bar are also Black Marketeers who buy and

sell contraband and stolen goods. They can also arrange transportation of "hot" goods, and help fugitives escape the law. Casavant runs the entire operation. **Alignment:** Anarchist. **Attributes:** I.Q. 19, M.E. 15, M.A. 21, P.S. 15, P.P. 14, P.E. 12, P.B. 13, Spd 14. **Experience:** 10th level Black Market Expediter.

Black Market "Associates":

James McDonald – 7th level Enforcer; Anarchist.

Chris Williams – 8th level Wilderness Scout; Anarchist.

David Nemoseck – 7th level Refurbisher; Anarchist.

Travis S. Guerrero – 7th level Forger; Anarchist.

Chad Lasecki – 7th level Information Broker; Anarchist.

Charles Pickering – 8th level Black Market Banker; Anarchist.

Eric Champion – 9th level Rift Runner; Anarchist.

Vernon Brown – 8th Smuggler; Anarchist.

Chequamegon Bay and the Apostle Islands

One of the most notorious pirate havens in Lake Superior is Chequamegon Bay and the Apostle Islands. Like **Black Bay** on the northern coast, Chequamegon Bay provides shelter from the lake's currents and the patrol boats that occasionally sweep the shipping channels. The Apostle Islands represent the border between human-held territory and the beginnings of the Xiticix Hivelands. Warriors patrolling from the Duluth Hive are much more common on the western side of the islands, especially now that the Tolkeen war zone has calmed down. Pirates have selected the islands, right on the buffer between human and Xiticix civilization, because neither one is willing to effectively monitor them.

Tolkeen's Great Lakes port used to be located to the east of the islands, close to Northern Gun and with easy access to Lake Superior. Rivers and magic canals allowed ships to sail from Tolkeen right to the lakes, but the Coalition Army has since destroyed most of the inter-river connections. The sailors and privateers who used to protect Tolkeen's shipping channels are also no longer a problem, giving pirates the run of the place now that the CS Army has moved on.

The Chequamegon Bay connects to the **ruins of Ashland, Washburn** and **Bayfield**, pre-Rifts communities that are now mostly rubble. Each one has a few hideouts that the pirates use to stash their ships out of sight or to hide particularly valuable plunder. The bay is sheltered from the open lake by a long sand spit and is a good place for any ship to take refuge in bad weather.

The Apostle Islands are where most of the pirates actually have camps and forts, protected from the mainland by the icy waters of Lake Superior. The islands were primarily a state park in the time before the Rifts, and except for Madeline Island, the largest, have virtually no ruins and nothing left behind to salvage. They are remote enough that a *Xiticix Scout* or *NG Blue Hawk* are rare sights.

Madeline Island was inhabited in pre-Rifts times and even featured its own airport. As the largest of the Apostle Islands, it is home to the largest pirate group and any others who manage to ally with them. The island is a low priority for Northern Gun, as close as it is, because western Lake Superior simply does not see the same amount of shipping traffic as the rest of the Great Lakes, especially now that Tolkeen is gone. The kingdom of magic had to use Lake Superior to trade with Ishpeming, the Manistique Imperium and other Great Lakes powers, and since their defeat by

the Coalition Army, the only traffic in the area comes from pirates, smugglers, local shipping out of Iron Bay, and *Task Force X* military forces monitoring the Xiticix threat. Some pirates have even taken to hunting Xiticix as a means of making money, trading in scalps for credits at Iron Bay or Ontonagon.

Eric Auger, Captain of the Black Skull Pirates, Quick Stats: Captain Auger is the leader of the largest group of pirates based out of Madeline Island. In truth, Auger and the majority of his crew (though not all) don't see themselves as pirates, but as freedom fighters still battling against the tyranny of the Coalition States. Until Tolkeen fell to the CS, the Black Skull Pirates (a reference to the death's head motif of the CS) were privateers and heroes fighting on the behalf of the Kingdom of Tolkeen. Without a kingdom to support them, Captain Auger and his "freedom fighters" continue to target only Coalition and Free Quebec (ex-Coalition) ships, including those hauling goods purchased by the CS. It is the mandate of the Black Skull Pirates to only steal and sell CS goods, embarrass Coalition troops (and their hired mercs and reps) rather than kill them (killing them only when left with no choice), and always try to spare the lives of innocent sailors and passengers. Ranking CS officers and officials are, sometimes, taken captive and held for ransom to further embarrass the CS. **Alignment:** Scrupulous. **Attributes:** I.Q. 17, M.E. 15, M.A. 20, P.S. 17, P.P. 19, P.E. 15, P.B. 13, Spd 12. **Experience:** 9th level Privateer. **Skills of Note:** Basic Mechanics, Literacy: American, Pilot: Military Warships and Patrol Boats, Pilot: Sail Boats, Pilot: Ships, Pilot: Water Scooters, Rope Works, W.P. Sword, W.P. Energy Rifle, and W.P. Heavy M.D. Weapons.

Captain Jim Cross, Second-in-Command, Quick Stats: Swashbuckling Captain Cross is the other charismatic leader of the Black Skull pirate fleet. He actually started life as a Rogue Scholar, but life and war carried him down a different path. He is a capable leader respected by his crew. **Alignment:** Scrupulous. **Attributes:** I.Q. 14, M.E. 13, M.A. 19, P.S. 14, P.P. 15, P.E. 14, P.B. 13, Spd 14. **Experience:** 7th level Pirate and 4th level Rogue Scholar. **Skills of Note:** Basic Mechanics, History: Post-Apocalypse, Law: General, Literacy: American, Math: Basic and Advanced, Pilot: Military Warships and Patrol Boats, Pilot: Motorboats, Race & Hydrofoils, Pilot: Ships, Rope Works, W.P. Energy Pistol and W.P. Energy Rifles.

Isaac Xavier-Santos, Ley Line Walker, Quick Stats: Isaac was born in the Magic Zone, where he learned the secrets of the mystic arts as a member of the Federation of Magic. A gentle soul, he left the Federation to live a peaceful life at the Kingdom of Tolkeen. There he was a scholar, artist and mage. The Coalition's Siege on Tolkeen destroyed Isaac's dreams for a better world, at least for the moment. He met Captain Auger when the pirate and his fleet were carrying refugees by the boatload to safety before Tolkeen fell to the CS. The mage was impressed with the hero's courage and compassion – coming back for refugees over and over again, right up to the final collapse of the Kingdom – and decided to stay on as a member of his crew. **Alignment:** Unprincipled. **Attributes:** I.Q. 15, M.E. 13, M.A. 12, P.S. 15, P.P. 12, P.E. 17, P.B. 14, Spd 13. **Experience:** 8th level Ley Line Walker.

Other notable Black Skull Pirates serving directly under Captain Auger:

Doug Brown – 7th level superhuman from another dimension; Scrupulous (with the abilities of Alter Physical Structure Metal and Growth/Giant Size).

Jeff A. Burke – 7th level Mind Melter; Scrupulous.

Lee Jones – 5th level Flame Wind Dragon Hatchling; Unprincipled.

Scott Jones – 6th level Delphi Juicer; Unprincipled.

Todd Kingery – 6th level Combat Cyborg; Scrupulous.

Kirk Ridich – 7th level Gunslinger; Scrupulous.

Keith Hall – 8th level Hunter Cat; Unprincipled.

Ontonagon

Task Force X, Northern Gun's Anti-Xiticix Division, is based out of Ontonagon, located just across Lake Superior from the Xiticix Hivelands. The city is a naval base, not a trading port. Before Task Force X moved in, it was just a backwater docking point for ships that carried cargo to customers along Wisconsin's Lake Superior shore. The encroaching presence of the Xiticix in Duluth, and the Coalition winning the war in Tolkeen, both cut down dramatically on the amount of trade that was taking that route. The alien bugs turned out to be Ontonagon's salvation, as they provided a reason not just to sustain the port, but to vastly expand and improve it. Thousands of fighting men and support personnel brought disposable incomes and a need for living materials and luxury goods. An equal number of family members have also relocated to the city, as a job with Task Force X actually comes with a somewhat reliable schedule and regular pay.

As well as having an excellent strategic location for watching the Xiticix, Ontonagon is situated along the only pair of ley lines that extend into the Republic of Ishpeming. While they do not form any known nexus points, the two lines are potent attractive forces for supernatural creatures, magical beings and practitioners of magic. With the exception of the portion within the *Porcupine Mountains*, activity along the two ley lines is well monitored and the area around them kept clear of "trouble." Forces from Ontonagon patrol the middle portion of the lines, while Houghton troops watch the northern section and border guards from Ironwood are responsible to the south.

Minnesota and the Xiticix Front. Northern Gun/Ishpeming, especially the northwest quarter away from the Wisconsin border, is not the economic center of the state. In the north, the winters are severe and there is a definite lack of developed trading partners. While the northeast section of the state is the center of trade with CS Iron Heart and the departure point for many vessels heading east, the opposing northwest has become the front line against the Xiticix Hivelands.

Dominating northern Minnesota and the adjacent portions of Canada, the Hivelands and their expansion have begun to threaten the western border of Northern Gun before any other major human kingdoms. The Trade Council is remarkably calm about this, relying on forces like the Coalition Army and the mages of Lazlo to deal with the bugs in the long term. Of course, anyone who can prove they are fighting the Xiticix is more likely to receive discounts on NG weapons and military gear (10-20% is standard), but Northern Gun is in no hurry to assemble an army and march into the deadly Hivelands.

Task Force X

The looming Xiticix threat to the west has prompted the Trade Council to permit the formation of the first standing army in Northern Gun's history. **Task Force X**, as it is officially known, is a well-organized division of mercenaries, skilled contractors,

pilots, scouts and Ishpeming volunteer soldiers specially trained to fight and hunt Xiticix. Equipped with a large number of power armor, aircraft, ships and hover vehicles, their task is to secure the western shore of Lake Superior, as well as the lake itself, and to monitor the Xiticix from listening posts in Minnesota. New hives and large swarms encroaching toward NG territory are not to be tolerated and are ruthlessly exterminated by the Task Force's patrols and punitive expeditions.

Deployed from a series of naval ships anchored just off the Minnesotan coast, the ground forces of Task Force X patrol the thin strip of ground along Lake Superior that has not been absorbed into the **Xiticix Hiveland**s, as well as the nearby **Apostle Islands** and the rest of Wisconsin's northern coast. They rarely launch sustained attacks inland, and do so only to ferret out and destroy new nests and when an individual hive or swarm appears to be massing. More often than not, Task Force X's job is simply to monitor the insectoids and provide a first defensive line and trip-wire should a swarm attempt to migrate towards Ishpeming. The soldiers have created a series of bunkers along the beaches that serve as shelters and quarters for the troops, and are intimately familiar with the coastal terrain.

During the worst Xiticix attacks, the probing force will retreat back to the shores of Lake Superior and take shelter under the immense firepower of the naval assets deployed to protect them. The Sea King missile cruiser *NGS Superior* is the flagship of Task Force X's naval complement, and is quite capable of warding off flights of Xiticix with its missile batteries and its wings of flying power armor. Only once has the entire task force had to retreat to its home base at Ontonagon: in the face of a particularly nasty Lake Superior winter storm. The Xiticix threat has also been the catalyst for many new giant robots and combat vehicles to have missiles and new weapon systems. In fact, the Mantis power armor was originally conceived to fight Xiticix.

Task Force X Military Assets

A Battalion: Scouting and recon. Approximately 400 soldiers.

B Battalion: Light infantry, Juicers, Crazies, light 'Borgs. Approximately 800 soldiers.

C Battalion: Heavy infantry, Full Conversion Cyborgs and mechanized forces. Approximately 600 soldiers.

D Battalion: Air-capable battalion. Flying power armor, jet pack-equipped and helicopter-mounted infantry. Approximately 350 soldiers.

Sealift Section: 12 Sandfish cargo landing ships, 4 assigned to each ground battalion.

Surface Escort: 8 Harbormaster missile boats that protect the larger ships.

Submarine Escort: 4 Bluestorm submarines, 2 of which stay near the Task Force at all times. The others travel across Lake Superior in long-range patrols.

NGS Mercy – hospital ship: The *Mercy* is a cargo vessel that has been refitted as the fleet's hospital ship. Occasionally it leaves the task force, spending a few weeks refitting in Ontonagon when there are no scheduled attacks or large patrols. The ship has beds for 48 wounded soldiers as well as 4 operating rooms and a substantial amount of medical supplies, including plasma, antibiotics and even bionic replacement limbs, eyes and organs. Staff includes five Body-Fixers, one Cyber-Doc, 10 nurses and a single Psychic healer.

3 Harbinger-class motherships: Used as landing ships and for staging smaller patrol vessels. Each ship carries a complement of 30 NG Marines, 10 of whom will have jet packs and 10 of whom will have some kind of NG power armor, typically Blue Hawks. Black Eel patrol boats, Beachmaster robots and all manner of small vessels, jet skis and minisubs are carried within the Harbinger's internal bays. Each Harbinger also operates a Fantail helicopter for transferring personnel and anti-sub/sea monster operations.

NGS Sea Lion – Triton-class patrol boat: One of a handful of Triton patrol boats purchased from Iron Heart Armaments, the *Sea Lion* has been taken off of pirate hunting duty and reassigned as the escort ship for the *NGS Superior*. It generally stays close to the *Superior*, but sometimes still serves as the command ship for pirate-hunting missions into Green Bay when NG's other Tritons are occupied. The *Sea Lion* carries 12 Robot Pilots in Blue Hawk power armor for air defense.

NGS Superior – Sea King-class missile cruiser: The flagship of Task Force X is the *NGS Superior*. A Sea King missile cruiser, the *Superior*'s launchers carry 640 medium- and long-range missiles of all types (non-nuclear), and another 560 missiles are kept in storage below decks. The ship also has 6 heavy torpedo tubes, depth charges and a pair of rail cannons along with a set of 8-inch naval guns that allow it to both defend itself and direct fire inland. In addition to a crew of 50, the *Superior*'s military complement includes:

Airborne Element – 20 Robot Pilots in Blue Hawk power armor.

Ground Element – 10 Robot Pilots in Samson power armor.

Amphibious Element – 10 Robot Pilots in Beach-Stormer power armor and 4 pilots operating Beachmaster amphibious assault robots.

VTOL Element – 2 Dragonfly hover choppers, 1 Liontail helicopter as a missile-spotter and 1 Fantail helicopter for anti-sub operations and transferring personnel. **Note:** See **Rifts® Mercenaries™** for stats and full information on the Sea King missile cruiser.

Christopher Kluge, Commander of Task Force X, Quick Stats: Commander Kluge is a resourceful and inventive leader who sees the Xiticix threat for the true danger it represents. He has taken it upon himself to go above and beyond the call of duty, with deep reconnaissance patrols to not only observe the enemy, but to identify its strengths and weaknesses, and devise strategies and tactics to counter strengths and exploit weaknesses. To the latter, the commander has approved numerous surgical strikes by special forces, and by hired adventurers and mercs, deep inside the Hiveland and even inside fledgling bug hives. **Alignment:** Scrupulous. **Attributes:** I.Q. 18, M.E. 13, M.A. 14, P.S. 20, P.P. 20, P.E. 16, P.B. 14, Spd 21. **Experience:** Equivalent to an 11th level CS Navy Sailor.

Brendan Blackmer, Captain of Task Force X Special Ops, Quick Stats: Captain Blackmer shares Commander Kluge's concerns about the Xiticix and is his "go-to guy" for surgical strikes and special operations. **Alignment:** Unprincipled. **Attributes:** I.Q. 15, M.E. 14, M.A. 10, P.S. 21, P.P. 19, P.E. 14, P.B. 12, Spd 15. **Experience:** Equivalent to an 8th level CS Nautical Commando Specialist. (See **Rifts® Sourcebook 4: Coalition Navy** for details.)

IMCN

Ishpeming Military Contract Network

Most states on Rifts Earth have their own armies that they use to protect themselves from hostile neighbors, rivals and monsters. The armies of the *Coalition States* and *New German Republic* are the largest and most infamous. Both are huge, professional militaries that use advanced technology to compete with magic and monsters. They use standardized equipment and tactics, and the warriors are citizens who are completely loyal and dedicated to the state they serve to protect.

Northern Gun's military could not be more different. Ishpeming and its surrounding cities have always been a haven for mercenaries and guns for hire. This goes back to the dark decades following the Great Cataclysm. As the corporation began to step into the role of a central government, they realized that some kind of military protection would be necessary. The dilemma was whether or not to create local defensive forces, a state-run military or a corporate army. The company management that would eventually evolve into the *NG Trade Council* considered a military force in the hands of the state government to be a mistake, and a serious threat to their power and control. A full-fledged corporate army would have its own problems as well, and certainly would not help diminish Northern Gun's reputation for fascist policies.

Instead, a new concept was developed, an alternative style of military that would be cheaper, more competitive and more flexible than the other options. Rather than form traditional military divisions, supply lines and training bases, Northern Gun simply hired mercenary units to protect the nation. Now, so many years later, Northern Gun corporation's possession of the purse-strings insures that the company executives maintain ultimate control over the mercenaries and privateers tasked to do the job. NG's "sponsorship" of certain troop units in the form of free and discounted equipment ensures even more loyalty.

By replacing a normal standing army with mercenary contracts, Northern Gun hires experienced and skilled combatants and forgoes the need to train, feed and house its own troops. The soldiers see to that themselves, and must stay within the confines of the terms of the contract. This forces mercenaries in Northern Gun's employ to stay thrifty and not risk their troops or equipment in brash or unnecessary assaults. Mercs are also left on edge, fighting to retain their jobs. While military units elsewhere may see their commanders relieved of duty after lost battles or poorly led actions, the NG Trade Council has no reservations when cancelling contracts and sacking entire units of military contractors should the mercs prove to be ineffective, incompetent, troublesome or too expensive. In fact, every mercenary company or combat group negotiates their own contract. That means based on the mercenaries' reputation, abilities, combat gear and their representative's ability to negotiate, each contract and payment is different. The best negotiators get the best pay, even if they are not the best fighting force.

Mercenary Forces of Northern Gun. Picking up a long-term contract with Northern Gun is every mercenary's dream job. Un-

like conditions almost everywhere else in North America, protecting the borders of Ishpeming comes with stability, security and the luxury of staying in one place. And not just one place, but the Disneyland of civilization. And the mercenaries are paid with a guaranteed monthly salary instead of receiving their compensation on a per-battle basis. This means that mercenaries can make more money than ever before, and all without the need to risk their lives in daily combat.

There are many roles a mercenary company can step into and fulfill, many of them cushy compared to most field work and combat assignments. During the winter, the weather in the Upper Peninsula is so severe that there is very little violence of any kind. Over these long months, many mercenary companies take the time to rest and relax, falling back on an easy indoor training schedule and not aggressively patrolling their assigned sectors. To let an attack or Black Market raid slip by completely unnoticed is a contract-ending offense, however, so most merc contractors try to keep their eyes and ears open even during ferocious winter weather and respond quickly to danger.

Some of the toughest mercenaries on the continent are employed by Northern Gun. Not only are they hired for border protection, but law-enforcement duties, punitive missions against rivals and criminals, and quick strikes against uppity Black Market kingpins, pirates and raiders. Sometimes, mercenaries are secretly hired just to increase the level of political tension in areas away from the Republic, leading to increased demand for Northern Gun products by those who expect to come under attack. Mercenaries are expensive, so this technique is a last resort, but sometimes it is the only way to convince a stubborn kingdom or city-state that they need Northern Gun's weapons and vehicles to protect themselves.

IMCN Total Size

At any given moment, over 100,000 soldiers are listed on the roll of the IMCN (Ishpeming Military Contract Network); nearly 115,000 at their highest recorded headcount in 107 P.A. This includes support personnel, freelancers (adventurers without formal military rank or training who serve as specialists and in support roles in the NG military), mercenaries not under contract but living in Ishpeming or the Manistique Imperium, and retired "reservists" who have volunteered to be called upon only during times of emergency (and emergency pay rates). **Active-duty mercenaries** who are currently deployed on assignment or posted along the nation's borders usually number around 35,000, including the soldiers who make up Task Force X.

Rank Within the IMCN

The IMCN is focused on employing and deploying forces of mercenaries. How the mercenaries organize themselves within their own company and units is up to them. The IMCN requires no officer class or official enlisted ranks, trusting each mercenary group to figure out a system of command that works for itself. "Rank" within the IMCN is really all about pay, and pay-grades represent the time an individual has served with the Contract Network, their combat specialization and bonuses received for acts of heroism and going above-and-beyond the call of duty. No medals are awarded by Northern Gun, but cash bonuses and sales vouchers are liberally dispersed to encourage mercs to fight hard.

Monthly Pay Rates

Laborer/Unskilled Support Personnel: 1,000-1,500 credits per month.

Private: 2,000 credits per month.

Corporal/Wilderness Scout/Skilled Support: 2,400 credits per month.

Sergeant/Experienced Technical Specialist: 3,600 credits per month.

First Sergeant/Juicer: 4,600 credits per month.

Sergeant Major/Glitter Boy/Mind Melter: 5,200 credits per month.

Field Lieutenant/Combat Cyborg: 6,200 credits per month.

Captain: 8,000 credits per month.

Major: 12,000 credits per month.

Colonel: 20,000 credits per month.

General/Mercenary Commander: 50,000 credits per month.

Commissioned Officer Specialist: Get an additional 1,000-2,000 credits a month for their special skill set (Explosives/EOD Specialist, Operator, Medical Doctor, Cyber-Doc, Military Specialist/Espionage, Scientist, Special Forces, and similar).

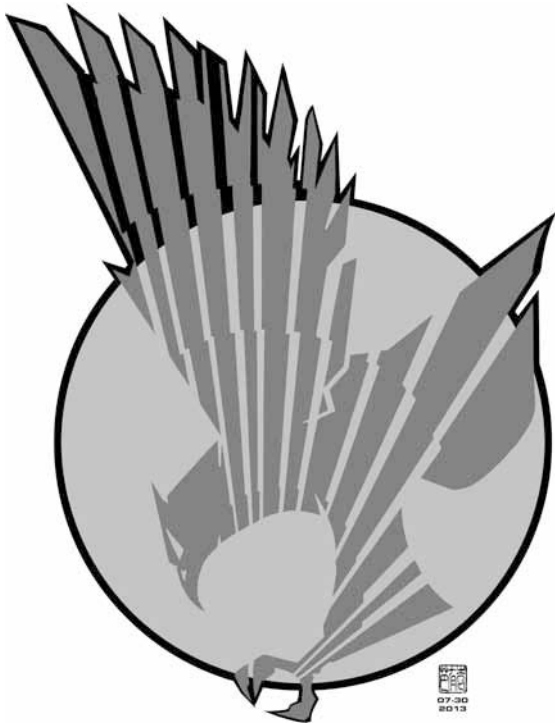

Identification as an IMCN Operative

All IMCN mercenaries hired by Northern Gun or Ishpeming wear an arm band with the IMCN emblem: A stylized blue eagle with talons out as if it were diving to attack, inside a red circle with a black border. The tips of the eagle's wings protrude slightly from the border of the circle. A similar decal is usually applied to the left shoulder of body armor/power armor. Additional identification such as a police decal on the other shoulder, chest and/or helmet, along with an I.D. number, may also be required.

Common Assignments for IMCN Mercs

Anti-Piracy: The main goal is to patrol the waters around the Upper Peninsula and chase away pirates and privateers. The brigands do not need to be destroyed, just scared away and chased off. This duty may also include ship escort and random patrols.

Border Patrol: One of the most frequent assignments for the IMCN is border patrol. The western border of Ishpeming is vast and rugged, marked by rivers in portions but with a long, central stretch of nothing but forests and mining camps. Privateers and marine forces are also hired to patrol Green Bay, Lake Michigan, Lake Superior and various rivers. Border patrols can either follow the border or launch recon on the other side, as no political power claims Wisconsin or Lower Michigan. The main purpose of the patrols is to uncover and dispatch potential threats to the security of the Northern Gun corporation and the nation.

Cargo Escort: For hovertrains and cargo haulers moving through dangerous territory, armed escorts typically provide a mobile defense to prevent the cargo from being stolen or destroyed. Most trips are arranged so that mercenaries escort the cargo to its destination, where they meet another shipment heading back to their original departure point. Sometimes jobs are one-way, but these are usually long duration assignments; trips to far-off customers like Chi-Town, Free Quebec, the Colorado Baronies, Pecos Empire or Ciudad Juarez, where the mercenaries must both protect and transport the cargo, and may go about their business once it reaches its destination.

Combat Troop Response: Just as the name suggests, a fighting force is dispatched to engage and destroy a hostile force or threat. Actually, this can be almost any assignment in which military action and combat is expected.

Competitor Discouragement: Though it is frowned upon by the Chief Councilor, sometimes, Northern Gun still resorts to old-fashioned, mob-style tactics. Competitors are intimidated or attacked, or their products are destroyed, stolen or befouled. Northern Gun rarely hires mercenaries for this kind of work anymore, preferring to use the much more secretive LPO (Loss Prevention Office).

Garrison Duty: Some of Ishpeming's cities, especially along the border, are so rowdy and out of control that they require occupying troops full-time to keep the peace or protect NG holdings. Garrisons are not so much law enforcement as a visible presence of Northern Gun's authority and power. Garrisons of troops are there to discourage pirates, bandits and enemies, and to respond to military-scale threats and monsters. Garrison troops are not police, and while they will put an end to fighting and shootouts in the streets, they are not trained or equipped to investigate crime scenes or to use a delicate touch in apprehending or interrogating suspects.

Law Enforcement: More focused and specific than garrison duty, law enforcement is actual police work. The mercenaries respond to emergency calls, patrol the streets, disperse crowds, investigate crimes, set up checkpoints, engage in riot control and provide security for public gatherings. Depending on the attitudes of the mayor or NG overseer, they may also help strong-arm the local populace, search for a fugitive, or even collect taxes and tolls.

Monster Hunting: Even though it is mostly bereft of ley lines, Northern Gun is still on Rifts Earth, and its dense woodlands and rustic reaches are stalked by dangerous creatures. Moreover, NG is surrounded by wilderness, home of such creatures. While some are supernatural, some are alien animals, and some are creatures of magic or things from beyond a Rift. The most destructive and deadly are tracked down in regular monster sweeps and coordinated hunts. *Official Monster Responders* frequently call upon IMCN forces when they need superior firepower, equipment

and numbers. Monster hunting assignments up and down the IM Highway, the Escanaba Road and other trade routes are routine, as well as coastlines and the populous region around Ishpeming, the Iron Fields along the western border and the country surrounding any population center or holding within and around the Republic.

Reconnaissance/Scouting: The deployment of combat troops to investigate reports of monsters, danger, illicit activity, enemy troop build-ups or operations in and around Ishpeming. Recon patrols are usually designed to gather intelligence and confirm the presence and location of a threat, not to engage it. Engaging a threat will be done via surgical strike or combat troop response.

Sea Monster Fishing: Just like monster hunting jobs, Northern Gun also pays mercs, privateers, ship captains and professional fishermen to eliminate sea monsters in waters off its coastlines. The Big Bay de Noc and the coasts of Marquette, Menominee and Ontonagon are all areas the company sweeps for sea monsters frequently, as well as the Keweenaw Waterway and the nation's handful of canals and rivers. There are fixed prices that Northern Gun pays for the heads of sea monsters caught within its territorial waters, and there are even people who would be considered fishermen before mercenaries who make a living thinning the numbers of lake serpents around Ishpeming.

Security Detail: Assigned to guard, accompany and protect a specific person, item or location with strategic, political or commercial importance. This can be a foreign dignitary, CS representative, a wealthy customer, royalty, NG exec or design team, someone targeted by an enemy or rival, a prototype device or plan, crime scene, specified location, and so on, but it usually involves guarding a person or group of people.

Search and Destroy: Pirates, sorcerous enclaves, Naruni dimensional staging points, Black Market thieves, mutinous mercenaries, demons and dens of dangerous D-Bees are all targeted from time to time by the Trade Council. Mercenaries are used much more often than the LPO for search and destroy missions as they are true combat troops, and these assignments can be risky or may require Northern Gun to distance itself from the action at a later date.

Surgical Strikes: These are usually targeted assaults, attacks and raids designed to cripple, scatter and/or destroy an enemy force. Such attacks may be made against enemy and criminal personnel, their vehicle or vessel, or a specific target (communications, weapon system, etc.). Surgical strikes may also be used to rescue kidnap victims and other captives from enemies or criminals.

Contract Bidding

Highly competitive bidding matches are Northern Gun's chosen method for hiring military contractors. Bidding keeps the cost down and motivates mercenaries to think of cheaper, smarter ways to get their job done. Some mercenary companies manage to accomplish their assigned tasks with minimal expenditure of cash and resources, while others use expensive equipment and liberal manpower to make sure they don't have to do the same job twice. A mercenary fighting for a paycheck is almost as dangerous as one fighting for his life.

Short-term contracts can last a few days or a few weeks. Typical long-term contracts run for only six months or a year before renegotiation. Only a few last 2-3 years before they come up for review. New mercenary companies that have yet to build a reputation are likely to see a one to three month trial period instated to see if they have the skills and resources to do the job to NG's

satisfaction. Many have tried to cheat the IMCN in the past, but, with a few exceptions, the competitive nature of the organization keeps most of the mercenary groups surprisingly honest. Working for Northern Gun is a highly desirable position for a mercenary. The paychecks are reliable, the assignments are often defensive in nature, and there is always the promise of bonuses in the form of free gear, vouchers and discounts.

IMCN School of Soldiery

In order to better train and prepare mercenaries who fight for Northern Gun, the Trade Council has established the IMCN School of Soldiery. Formerly the Ishpeming Military Academy, "the School," as it is commonly referred to amongst mercs, has been expanded and opened its admissions to anyone who can afford to pay tuition. Active-contract IMCN mercs typically have free or reduced prices, letting them send their new recruits to *boot camp* and *cross-train* soldiers who already know their way around the battlefield. Many small states and merc companies unaffiliated with the IMCN also send students to the School of Soldiery, creating a rather diverse mix. The children of mercs learn alongside royalty from small kingdoms and corporate security personnel enrolled by their employers.

Different areas of expertise have their own subsections of the school. There is the Infantry Center, the Robot/Power Armor Center, Air Combat Center, Naval Warfare Center, Field Medic Center and the Special Operations Center. Each one has its own training regimen and produces a very different type of soldier. And of course, all are trained using NG gear, creating a bias in favor of Northern Gun products.

At the School, unskilled or semi-skilled mercenaries are transformed into warriors. There are small classes in SCUBA diving, parachuting, demolitions, and other specialist skills going on at all times, in addition to the normal training program. The majority of instructors are ex-mercenary soldiers hired up by the School. There are vets from the militaries of many nations working at the facility, from former Manistique troops to ex-Coalition soldiers.

While infantry training may not be terribly rare on Rifts Earth, specialists like robot pilots, power armor troops, combat drivers, field mechanics, combat medics, and particularly, aircraft pilots, are much harder to produce. The right gear, special training facilities and instructors are all necessary, and the IMCN School of Soldiery is one of the few places in the world that individuals can receive that type of training with no connection to a state army or institution. The School has simulators for learning to use every type of Northern Gun vehicle, as well as programs that simulate generic planes, tanks and 'bots. The aircraft training is notably difficult and involves numerous real takeoffs and landings as well as plenty of time in the simulator. A large percentage of North America's helicopter and fixed-wing aircraft pilots either received their flight training at the School or practiced with an instructor who did.

Annual Mercenary Exercises

Staged every year within the deep forests of the Republic of Ishpeming, the *AME Convention* is a gathering of every military contractor, mercenary and privateer working for the IMCN. Entire companies rarely attend; instead, leaders and individual units from within the mercenary companies come out for the exercises as ambassadors and advisors.

With the troops assembled, two opposing forces are created and armed with training weapons. Using lasers and sensors that register “hits,” the AME is the world’s largest game of laser tag, and pits many diverse opponents against each other. The goal of the exercises is to encourage cooperation and competition amongst the IMCN’s mercenaries. Mercenary companies gain experience working alongside or against each other in many different combinations. Multiple mercenary companies are often deployed to launch punitive expeditions and to deal with major threats, so it makes sense to give them practice working together. And if a mercenary company ever goes rogue, the NG Trade Council is sure to look up the last opponents they faced in these war games and offer them the job of containing and defeating their former rivals.

In addition to all manner of mercenaries and Northern Gun technical and military advisors, troops from the Manistique Imperium also often participate in the exercises. The armies of the two states enjoy a level of rivalry, but it is a healthy rivalry and most soldiers know that the two forces will be working side-by-side if the Upper Peninsula is ever threatened. The Coalition States actually extended a request to take part in the 108 P.A. exercises, but overwhelmingly negative reactions from the mercenaries of the IMCN led the NG Trade Council to propose a combined naval exercise instead. The seagoing forces of Task Force X worked alongside the CS Navy in a highly-publicized sweep of Lake Michigan. The Coalition was duly satisfied and Northern Gun’s mercenaries never had to cooperate with the widely-despised CS Dead Boys.

Field Marshal Philip Reeves

Military Councilor, Commander of the IMCN

A former mercenary of unparalleled experience across North America, Philip Reeves has been fighting on the battlefields of Rifts Earth since Colonel Larsen of Larsen’s Brigade was in diapers. He has fought both with and against the Coalition in ages past, along with numerous clients from Free Quebec to Kingsdale, but long ago discovered that the real money to be made was in working for the private corporations.

From 100 to 105 P.A., Reeves was the head of security for **Wilk’s Laser Technologies**. He insured the safety and integrity of their headquarters in *South Dakota* and managed armed escorts for sales shipments destined for customers all over North America. For the last year or two of his term of service, agents from Northern Gun had been tempting Reeves with various offers. Reeves stonewalled them for a time, but their price just kept going up. Finally, he relented; won over by the nature of the job, more than the paycheck. For Wilk’s he did security for a corporation. For NG, Reeves runs security for an entire country, not to mention the largest sales and distribution network in North America.

As head of the IMCN, the primary duty of the Military Councilor is to organize mercenaries and make sure that Ishpeming’s borders, ports and resources are properly guarded. Managing **Task Force X** has recently been added to the job description, and Marshal Reeves is thrilled to be able to inspect the troops and hold parades. Training and equipping the shadowy **Loss Prevention Office** is also Reeves’ responsibility, though the Office’s current overseer has that task well in hand, and only sends requests and procedures to the Military Councilor’s office to be rubber-stamped.

Field Marshal Reeves is an experienced soldier who takes his job very seriously. He is an extremely cool customer who always seems to be one step ahead of his opponents. The South

Dakota bandits who had preyed on Wilk’s shipments for years were practically wiped out after he took charge of Wilk’s security, and now those who steal from Northern Gun are getting the same close attention. When the mercenaries protecting the western frontier went rogue in 106 P.A. and tried to establish their own mini-state in Wisconsin, it was Colonel Reeves who led the attack that showed them just how unrealistic their plans were. He took two merc companies across the border and used them to conduct a brilliant, two-week campaign of misdirection and maneuver warfare that left his opponents confused, demoralized and cut off from their supplies. The few rebel mercs who survived were imprisoned in Ishpeming and the IMCN has been quiet and orderly ever since.

Philip Reeves Stats

Real Name: Philip Reeves.

Aliases: None.

Race: Human.

Alignment: Unprincipled.

Attributes: I.Q. 19, M.E. 14, M.A. 21, P.S. 15, P.P. 12, P.E. 13, P.B. 12, Spd 11.

Height: 6 feet (1.8 m). **Weight:** 205 lbs (92 kg).

Hit Points: 41. **S.D.C.:** 22.

Age: 54

P.P.E.: 9

Experience: 9th level Special Forces.

Description: Reeves is a clean cut, no-nonsense soldier who is rarely seen without his IMCN dress uniform or field utilities. He has been putting on weight as a side-effect of his new office job (working for Wilk’s involved a lot of time in the field), but is otherwise in excellent physical condition.

Disposition: Calm and steady, Field Marshal Reeves is a deliberate thinker and strategist. He keeps his cool in any scenario and is just the man you want in charge during an emergency. While other NG execs may panic and overreact to raids or disasters, Reeves is likely already onsite, cleaning things up with the aid of mercenary troops and the Loss Prevention Office.

Skills of Note: Computer Operation 85%, Intelligence 79%, Literacy: American 90%, Pilot: Tanks & APCs 68%, Pilot: Robots and Power Armor 80%, Robot Combat Elite: NG Blocker, Radio: Basic 95%, Sensory Equipment 80%, Running, W.P. Energy Pistol, W.P. Energy Rifle, W.P. Paired Weapons and Hand to Hand: Expert.

Attacks per Melee: Six.

Bonuses: +1 on Perception Rolls, +2 on initiative, +2 to strike, +3 to disarm, +3 to parry and dodge, +5 to pull punch, +4 to roll with impact/fall.

Psionics: None.

Magic Knowledge: None.

Weapons of Note: NG-56 light ion pistol and NG-LP25 laser pulse submachine-gun are constantly at his side.

Body Armor: Typically wears NG-A8 Scout Armor.

Vehicles: Has a Mobilon rolling field base that he uses as a field headquarters. Is often flown around in a Fantail helicopter or Skybunker hover carrier, and uses a Blocker combat robot with a communications suite as his command vehicle in battle.

Cybernetics: Clock calendar, gyro-compass, bionic lung, and 4 bionic ribs. His original ribs and lungs had to be replaced after Reeves survived a laser blast.

Notable Military Contractors Within the IMCN

Big Money Militia

There is one contractor that stands out even amongst the showy mercenaries of the IMCN. **The Big Money Militia**, a robot-jock outfit formerly based out of MercTown, has relocated to Northern Gun in order to serve as border defenders. Their name says it all, and the mercs have developed quite a reputation throughout Ishpeming as big spenders and can frequently be found amongst the clubs and casinos of Ishpeming and Menominee.

The Big Money Militia is stationed along the western border with Old Wisconsin, and their duty is to secure and protect the border crossings and the rich iron mines in the area. The majority of their troops are stationed at *Ironwood*, concentrated to act as a “reaction force” if anything unexpected should occur. Small units are deployed at *Iron Bay*, *Iron Mountain* and *Iron River*. Menominee has its own defenders, **Duckworth’s Marines**, who coordinate with the Big Money Militia to protect the western and southern approaches.

Big Money Militia

- A. Sponsorship: Government.
 - B. Outfits: Specialty Clothing. 20 points.
 - C. Equipment: Medical Clinic, Electronic Supplies and Good Gear. 25 points.
 - D. Vehicles: Specialty Vehicles. 30 points.
 - E. Weapons: Advanced Weaponry. 20 points.
 - F. Communications: Full Range System. 15 points.
 - G. Internal Security: Iron-Clad. 20 points.
 - H. Permanent Bases: Fortified Headquarters. 20 points.
 - I. Intelligence Resources: Psionic and Magic Operatives. 20 points.
 - J. Special Budget: Large Loans. 25 points.
 - K. General Alignment of Personnel: Anarchist and Unprincipled. 4 points.
 - L. Criminal Activity: Cyber-Doc, Smugglers and Sellers of Contraband, Special Forces. 40 points.
 - M. Reputation/Credentials: Known. 10 points.
 - N. Salary: Excellent Salary. 20 points.
- Total Points Spent: 269
Size & Orientation: Large Company.

Company Strategy & Tactics: While its members live like celebrities and are known for their wild parties and carefree lifestyle, the BMM is a fairly traditional military company when it comes to its combat tactics. Small units of infantry are assigned to work with combat robots. They support and protect the larger vehicles as they move up and use their heavy firepower to knock out targets. Robot pilots know to move slowly as to not leave their infantry support behind, and infantry are always ready to follow their robots when exploiting a breakthrough.

The Militia has recently been gifted a small unit of Bigfoot robots from Northern Gun for support in case of a Xiticix attack on the western border. The company has assimilated them into their tactical doctrine, backing up each AA robot with troops armed with mini-missile launchers and rail guns to put even more lead up into the skies.

Company’s Colors and Banners: The letters BMM in a metallic gold on a black field.

Standard Issue Weapons:

Side Arm: Northern Gun pistol of choice.

Primary: Northern Gun rifle of choice.

Body Armor: NG-A10 body armor.

Other: Walkie-talkie, 1D4 hand grenades, 1D4 flares, survival knife, first-aid kit, flashlight, nightvision goggles, 1 pair of M.D.C. handcuffs and 4D6 zip ties.

Notable Combat Armor & Vehicles:

8 Samson power armor suits.

1 Glitter Boy.

8 Alligator amphibious APCs.

4 Hunter Mobile Guns.

2 Blocker combat robots.

4 Gunbot combat robots.

2 Gunwolf assault robots.

4 Bigfoot command and control robots.

Notable BMM Personnel & Troops:

Colonel Jeremy Jeffrey, Quick Stats: Colonel Jeffrey is the man responsible for bringing the Militia up from MercTown and getting them their sweet, new assignment with Northern Gun. All of the old pros feel indebted to him, and the new crop of recruits from Northern Michigan have only ever served under his command. Jeffrey is quietly making a small fortune for himself and planning for the day that he hands the company off to Major Auklund and retires to a quiet place in the Ishpeming countryside. **Alignment:** Unprincipled. **Attributes:** I.Q. 14, M.E. 13, M.A. 18, P.S. 15, P.P. 20, P.E. 19, P.B. 13, Spd 12. **Experience:** 7th level Robot Pilot.

Major Kate Auklund, Quick Stats: The BMM’s second in command is a lifelong professional soldier. Major Auklund is still adjusting to working away from MercTown and is amazed that the company is making money without having to do much more than patrol and hunt monsters and bandits. She is more of a risk-taker than Colonel Jeffrey, so she is always pushing for special missions to bring in extra cash and add to the Militia’s reputation amongst the IMCN. **Alignment:** Scrupulous. **Attributes:** I.Q. 15, M.E. 17, M.A. 10, P.S. 24 (Augmented), P.P. 21, P.E. 14, P.B. 14, Spd 66 (bionic; 45 mph/72 km). **Experience:** 7th level Headhunter.

Lieutenant Havasco, Quick Stats: Havasco runs the company’s Special Operations detachment, composed of Juicers, Special Forces soldiers and handpicked power armor commandos. Havasco works quietly and efficiently, a veteran of small-scale warfare between minor kingdoms throughout the Midwest. His mind powers are especially handy for interrogating enemy captives, accessing the thoughts of prisoners and keeping good measure of the soldiers in the BMM. **Alignment:** Anarchist. **Attributes:** I.Q. 17, M.E. 21, M.A. 10, P.S. 13, P.P. 12, P.E. 11, P.B. 12, Spd 11. **Experience:** 6th level Mind Melter. **Psionics:** I.S.P.: 115. Abilities include Bio-Manipulation (10), Empathy (4), Empathic Transmission (6), Hypnotic Suggestion (6), Mind Block Auto-Defense (special), Mind Bond (10), Object Read (6), Telepathy (4), Radiate Horror Factor (8), and other psi-powers.

The Bad Boys Infantry Company: 160 infantry soldiers of various O.C.C.s including 30 Special Forces, 20 Wilderness Scouts, 20 Headhunters, 10 Full Conversion Cyborgs and 10 Psi-Stalkers. All 1D4+1 level of experience, Anarchist and Unprincipled with a few Scrupulous alignments. They are led by **Major Eric Crump**, a Scrupulous, old-school, 9th level Robot Pilot whose favorite 'Bot is the NG Hunter Mobile Gun and favorite power armor is the Samson.

Robot and Power Armor Company: 48 Robot Pilots, half of them piloting a variety of NG combat robots and half in NG power armor. The company is led by **Captain Rick Bray**, Unprincipled, 7th level Robot Pilot, whose favorite 'Bot is the NG Wolverine and favorite power armor is the Mantis.

Juicer Platoon: 42 Juicers: 20 conventional Juicers, 8 Juicer Scouts, 6 Titan Juicers, 5 Hyperion Juicers, and 2 Juicer Assassins. They are all 1D6 level and led by **Lieutenant Stephen Butka**, Anarchist, 6th level Mega-Juicer.

Non-Combatants: Each of the three cities where the troops are garrisoned has a small district or base camp where most of the mercenaries' family members live. There are 50+1D4x10 family members and support personnel in town at any given time. Some of whom are the company's Operators, Body Fixers and other technical support.

The Lakeguard

The Lakeguard is the most infamous mercenary group to be part of the IMCN (Ishpeming Military Contract Network) since Larsen's Brigade took on a three month stretch of border duty during their last period of downtime. The Lakeguard is a privateer group with a long tradition of excellence out on the waves of the Great Lakes. Or so they say. For many years, the Lakeguard has undergone relatively few military missions and generally just basked in its position of prominence within the IMCN. Yet somehow, the number of pirates and smugglers they catch has remained constant. The NG Trade Council is unsure if the recent reports of the Lakeguard's inactivity are just inaccurate or if they are so efficient that pirate-related incidents are minimal. Until the numbers change, the Lakeguard will continue to hold onto their prized assignment.

The truth behind the Lakeguard's effectiveness is quite simple and known to most of the pirates of Green Bay. The Lakeguard has been around long enough that it has connections to many pirates, privateers, smugglers, ship captains, and other freebooters. Instead of going out hunting for pirates and actually "doing their job," the Lakeguard instead uses its resources to get their hands on individuals on Northern Gun's wanted lists, pirate newcomers who compete with their friends, and cheap boats that can be passed off as captured smuggling vessels. Through their criminal connections, the Lakeguard makes themselves seem much more active and much less corrupt than they really are. Best of all, they are getting paid by NG and collecting 15% from the pirate booty; the Lakeguard's cut for being so helpful.

While they are a far cry from most of the professional mercs of the IMCN in overall conduct, the Lakeguard is still a force composed of skilled warriors. Their willingness to use magic and dirty tricks also makes them crafty and dangerous. The Lakeguard is not in a rush to get into a fair fight with anyone, and when they do actually assemble their forces and attack unlucky pirate havens and smugglers' camps, they are sure to strike in the dead

of night and with the benefit of surprise. They are willing to defend Northern Gun's coastline from raiders and enemies, and are capable fighters, they just avoid doing so to their pirate buddies. However, if the battle goes poorly, this self-serving group will be the first to retreat.

The Lakeguard

- A. Sponsorship: Criminal – Organized Crime.
- B. Outfits: Specialty Clothing. 20 points.
- C. Equipment: Medical Equipment, Electronic Supplies and Good Gear. 15 points.
- D. Vehicles: Specialty Vehicles. 30 points.
- E. Weapons: Advanced Weaponry. 20 points.
- F. Communications: Full Range System. 25 points.
- G. Internal Security: Iron-Clad. 20 points.
- H. Permanent Bases: Company Town (Chambers Island). 40 points.
- I. Intelligence Resources: Special Military Operatives, Psionic and Magic Operatives. 30 points.
- J. Special Budget: None. 0 points.
- K. General Alignment of Personnel: Anarchist. 2 points.
- L. Criminal Activity: Prostitutes, Cyber-Doc, Smugglers and Sellers of Contraband, Expert Assassin, Special Forces. 65 points.
- M. Reputation/Credentials: Scoundrels. 1 point.
- N. Salary: Excellent Salary. 20 points.

Total Points Spent: 288

Size & Orientation: Large Company.

Company Strategy & Tactics: The Lakeguard have strong sea, air and land components. They employ psychics in their official registry, and secretly cooperate with practitioners of magic and D-Bees during their missions, and even hire some off the books. The Lakeguard's reputation serves them as well; most pirates prefer to retreat from the Lakeguard, knowing that they will most likely be allowed to escape once enough shots have been fired to qualify as a battle and to look good for anyone watching.

For attacking hostile shores, the Lakeguard has a pair of freighters and a pair of Sandfish Cargo Landers that have been rebuilt into amphibious assault ships. The freighters have giant ramps on their front and back and release smaller craft to strike the beach. The Sandfish pull right up onto the shore and deposit troops and ground vehicles to push inland and secure the objective.

In naval battles, the Lakeguard relies on traditional forces like ships, submersibles, combat robots and power armor. When away from witnesses and populated areas, their forces include 2D4 practitioners of magic and a handful of D-Bee specialists. Their combined firepower is usually enough to bring down most pirate vessels and small flotillas whenever necessary, and scare off any others who might be watching. Their anti-sub/sea monster hunting element is extremely skilled, efficient and well-equipped. The monster hunters are professionals of Unprincipled and Scrupulous alignment who try to turn a blind eye to the rest of the company's wrongdoings and focus on their work.

Company's Colors and Banners: A field of blue waves on a black, half-circle background.

Standard Issue Weapons:

Side Arm: NG-35 laser pistol with blue-green conversion.

Primary: NG-P5 Light Particle Beam Rifle.



Body Armor: NG Explorer Armor. Bullfrog or light armor with flotation device for amphibious assault troops. Plastic Man or other light armor for sailors and crewmen.

Other: Short-range personal radio, 1D6 hand grenades, 1 week's worth of combat rations, 2 signal flares, flotation device, emergency SCUBA tank (pony bottle) and 2D4+2 extra E-Clips.

Certain individuals will receive magic or Techno-Wizard items for missions depending on their own abilities and the overall plan.

Notable Ground Vehicles:

- 12 Beach-Stormer power armor suits.
- 8 Windshark hovercycles.
- 4 Alligator amphibious APCs.
- 4 Crocodile amphibious tanks.
- 4 Beachmaster amphibious assault robots, 1 "ship-hunter" variant.
- 4 Hunter Mobile Guns.
- 4 NG Super Max combat robots.
- 1 Blocker combat robot.
- 2 Grizzly combat robots.

Notable Naval Forces:

- 4 Speedboats.
- 2 Harbormaster missile boats.
- 4 UB-300 Mini-Subs (see page 143 of *Rifts® Underseas™*).
- 8 Subcycle hoversubs.
- 1 Bluestorm submarine.
- 2 freighters converted as amphibious assault ships.
- 2 Sandfish Cargo Landing Craft.
- 1 freighter converted as a decoy, heavily armed. (See random freighter creation tables.)
- 1 Triton patrol boat (see page 118 of *Rifts® Mercenaries™*).

Chambers Island, Lakeguard HQ: The Lakeguard watches over Green Bay from their private fortress on Chambers Island. Nestled well inside the bay, the island receives some protection from the full fury of Lake Michigan and is centrally located. *The Fox River* that leads south to Lake Winnebago and the Northern entrance to the bay are both relatively close, and the Lakeguard can respond very quickly if it feels the need. Most of the island is highly secure, particularly the headquarters and the areas where ships are docked. The Lakeguard doesn't worry much about in-

ternal security, however, as they have little to fear. Most pirates in Green Bay realize that getting rid of the Lakeguard would simply force Northern Gun to deploy another privateer company to guard the bay, and probably one who would actually do their job. As a result, the biggest threat to the Lakeguard are sea monsters crawling ashore.

Mackaysee Lake, the Tub: One of the major reasons the Lakeguard chose Chambers Island as their base of operations is *Mackaysee Lake*. The inland lake dominates a large fraction of the island, and is completely sheltered from the currents and storms that wrack Green Bay. Normally it is inaccessible to ships, but the Lakeguard have built a pair of locks and a small canal that allows their vessels to reach the lake. Inside, they are safe from violent winter weather, enemy ships and sea monsters. Dubbed, "the Tub," Mackaysee Lake has been fitted with numerous docks and a fueling station, and has long beaches where small watercraft can be dragged ashore. The lake is the most heavily guarded and patrolled section of the island, particularly the locks that are crucial to vessels moving back and forth from Green Bay.

The Lakeguard Command Center: Overlooking Mackaysee Lake is the Lakeguard's command center and headquarters. A small fortress poured from Mega-Damage concrete, the command center is where the Lakeguard counts and organizes their stolen booty. It is a combination living quarters, training center and treasure hoard. Built on the inland side of the lake, the command center is set between a pair of artificial hills that block the line of sight of ships firing on it from Lake Michigan. It has a view presiding over Mackaysee Lake and its guns control the small body of water, able to reach right out to the locks that enter the lake if they have to.

Below the command center lies the Lakeguard's secret prison. This is where the smugglers, bootleggers, pirates, fugitives, cast-offs and unfortunate pawns who serve the privateers' schemes are kept. If anyone from Northern Gun were to ask, the Lakeguard would explain that everyone in the prison is a pirate or wanted criminal. In reality, most of the charges the Lakeguard accuses them of are false. Their only crime was to be on the losing side of a contest between various illegal factions. They are rounded up, often in the dead of night, and taken to Chambers Island. There they will be held for anywhere from a few days to a few months

before finally being delivered to Northern Gun authorities as pirates.

Notable Lakeguard Personnel:

Admiral Sean O'Neal, Quick Stats: The founder of the Lakeguard is a career navy man who served in the Coalition Navy. As a relatively wealthy naval officer stationed in Iron Heart, O'Neal traveled extensively throughout the Manistique Imperium and Ishpeming, making contacts within the shipping and privateering industries. Taking early retirement from the CSN, he secured a loan from the NGMI bank to acquire the ships and power armor he would need to form a privateer company. This group would become the Lakeguard.

The admiral used his privateers to carry out big contracts for Northern Gun, clearing out their territorial waters. His career was following a predictable pattern until he met *Phillip Motts*, a pirate captain pretending to be a legitimate sailor. Motts and his men turned out to be the next target on O'Neal's list, and the two men struck a deal. Motts' pirate crew would abandon their camp and head over to Lake Huron and the Manistique Imperium for the rest of the piracy season, and give O'Neal 15% of their ill-gotten gains. The admiral liked the deal, fired a few shots at the camp for show, and the two groups both got what they wanted without risking life or limb. It was the beginning of the Lakeguard's entire future strategy. Motts introduced O'Neal and his officers to a whole range of pirates willing to help him scam the Ishpeming government, and for almost ten years they have prospered by cheating the system. **Alignment:** Anarchist (started out as Scrupulous). **Attributes:** I.Q. 18, M.E. 11, M.A. 10, P.S. 19, P.P. 15, P.E. 14, P.B. 12, Spd 13. **Experience:** 10th level CS Navy Sailor.

Captain Phillip Motts, Quick Stats: Captain Motts has become the Lakeguard's liaison to the world of piracy. A middling pirate captain before he met Admiral O'Neal, Motts is now infamous amongst the pirates and freebooters of the Great Lakes. He is known for running circles around Ishpeming's coastal defenders and paying off any border guards he cannot trick. Since joining the Lakeguard, Motts has conducted almost no piracy himself, using his knowledge and experience to play Northern Gun for fools instead. **Alignment:** Anarchist. **Attributes:** I.Q. 15, M.E. 10, M.A. 23, P.S. 13, P.P. 20, P.E. 13, P.B. 16, Spd 66 (bionic; 45 mph/72 km). **Experience:** 9th level Pirate.

Captain Gregory John Ullman, Quick Stats: Ullman is the leader of the Lakeguard Monster Hunters. He and his platoon of 60 monster hunters are dedicated to keeping the coastal waters safe. **Alignment:** Scrupulous. **Attributes:** I.Q. 15, M.E. 13, M.A. 20, P.S. 15, P.P. 21, P.E. 15, P.B. 12, Spd 19. **Experience:** 9th level CS Nautical Commando Specialist from Free Quebec, retired. Has even managed to acquire a *Quebec Sea Dragon Power Armor* for underwater ops, and a *Violator SAMAS* for aerial engagements. Both are his favorite power armor suits.

Notable Monster Hunters Serving Capt. Ullman:

Dylon Amersasinghe – 7th level Burster, Unprincipled.

Jeremy Berkowitz – 7th level Robot Pilot, favors power armor, Unprincipled.

Cory Crandall – 6th level Earth/Air Elemental Fusionist, Anarchist.

Josh M. Kaplan – 7th level Merchant Marine, Scrupulous.

Jeff Maltby – 6th level Water Warlock, Unprincipled.

Michael Sausaman – 8th level Ocean Wizard, Scrupulous.

Nate Swalve – 6th level Robot Pilot, Beachmaster robot, Unprincipled.

Steven Whittredge – 9th level Psi-Stalker, Anarchist.

Standard Infantry: 250 soldiers of various types, including 20 Wilderness Scouts, 30 Special Forces, 30 Privateers, 15 Headhunters, 20 Juicers, 10 Crazyies, 20 Full Conversion Cyborgs, 10 Bounty Hunters and 10 Mind Melters. Led by Commander **Bradley Reeser**, 9th level Glitter Boy Pilot, Anarchist.

Heavy Support Platoon: 32 Robot Pilots and vehicle crew who man the robots and ground vehicles. The man in charge is **Sergeant Timothy Dixon**, 10th level Robot Pilot, Anarchist.

Air Detachment: 40 Robot Pilots and aircraft pilots who operate flying power armor and aircraft. The man in charge is **Lieutenant William Shaffer**, 9th level Robot/Power Armor Pilot, Unprincipled.

Marine Detachment: 40 marines and 20 robot/power armor troops who conduct amphibious assaults and participate in ship-to-ship combat. Privateer, Special Forces and Robot Pilot O.C.C.s. The platoon leader is **Lieutenant Kevin Myers**, 9th level Commando, Anarchist.

Sailors, Crewmen and base personnel: Approximately 200 men and women who staff the company's ships, transport vehicles and facilities.

Non-Combatants: Chambers Island is also home to roughly 300 family members and support personnel. About half of the company's families live on the island, the rest live within Northern Gun.

Duckworth's Marines

The tough privateer company that protects and patrols Menominee is known as Duckworth's Marines. The Marines are amphibious warfare specialists, and whenever they aren't preoccupied with their duties in Menominee they are usually busy making a few extra bucks staging assaults on pirate camps, dimensional raiders, slavers and nests of sea monsters. They sometimes work with the Lakeguard, but Commodore Samuel Duckworth has learned not to trust the larger privateer group and prefers to conduct independent operations under his own command.

For a major military contractor, the Marines are an elite unit with a limited number of soldiers. Each one is a well-trained and experienced amphibious warfare expert, versed in SCUBA assaults, amphibious landings, ship-to-ship combat, and ship to land assaults via beach landings and air. Pirates and villains throughout the Great Lakes fear Duckworth's Marines for their ability to strike from the sea/lakes. When Northern Gun has decided a particular pirate outfit has become too troublesome, they turn to Commodore Duckworth to assemble an assault team and wait for favorable tides.

Duckworth's Marines

- A. Sponsorship: Independent.
- B. Outfits: Gimmick Clothing. 30 points.
- C. Equipment: Unlimited Equipment. 50 points.
- D. Vehicles: Specialty Vehicles. 30 points.
- E. Weapons: Advanced Weaponry. 20 points.
- F. Communications: Full Range System. 15 points.
- G. Internal Security: Tight. 10 points.

H. Permanent Bases: Fortified Headquarters. 20 points.
I. Intelligence Resources: Special Military Operatives. 10 points.
J. Special Budget: Large Loans. 25 points.
K. General Alignment of Personnel: Unprincipled and Scrupulous. 7 points.
L. Criminal Activity: None. 0 points.
M. Reputation/Credentials: Known. 10 points.
N. Salary: Good Salary. 10 points.
Total Points Spent: 237
Size & Orientation: Large Company.

Company Strategy & Tactics: Duckworth's Marines are serious amphibious warfare specialists. Their most important asset is their *Harbinger*-class mothership, the *Shorehammer*. It serves as a command vessel for amphibious assaults as well as carrying most of the amphibious tanks and smaller boats that will be used in the attack. The company also has a freighter that has been reconfigured as its mini-carrier. The freighter's deck has been extended to fit six landing pads for helicopters and hovercraft. The aircraft are used to support landing troops and to deliver additional forces inland.

Company's Colors and Banners: A heraldic white duck inset in a dark blue circle.

Standard Issue Weapons:

Side Arm: NG-56 Ion Pistol or NG-57 Heavy Ion Blaster.

Primary: NG-IP7 Ion Pulse Rifle.

Body Armor: NG-A20 Bullfrog Amphibious Armor.

Other: Short-range personal radio, 1D6 hand grenades, one week's worth of combat rations, 2 signal flares, one flotation device, emergency SCUBA tank (pony bottle) and 2D4+2 extra E-Clips.

Notable Ground Vehicles:

20 Beach-Stormer power armor suits.

6 Samson power armor suits.

4 Windshark hovercycles.

4 Beachcomber amphibious ATVs.

6 Alligator amphibious APCs.

6 Crocodile amphibious tanks.

2 Echelon hovertanks.

4 Beachmaster amphibious assault robots.

Notable Naval Vessels:

8 Small infantry landing craft (220 M.D.C. each).

4 Crayfish submersibles.

2 Harbormaster missile boats.

1 Sandfish Cargo Landing Ship.

Mini-Carrier: Freighter with 1,200 M.D.C. converted to carry up to 6 helicopters or hovercraft. Usually carries 2 Liantail spotters, 2 Fantails outfitted as gunships and 2 Fantails for medivac/troop deployment. Also generally carries up to 20 soldiers equipped with flying power armor.

The *Shorehammer*: *Harbinger*-class mothership. In addition to the smaller vessels and vehicles inside it, the ship also carries 30 Marines, 10 of who will have jet packs and 10 of who will have some kind of NG power armor, typically Beach-Stormer.

Notable Personnel of Duckworth's Marines:

Commodore Samuel Duckworth, Quick Stats: He formed the Marines many years ago. At that time there were far fewer privateers than the modern day, and almost none who could fight on shore as well as on the sea. He recruited the necessary special-

ists, from freighter crew and ex-pirates to amphibious warfare experts trained by state militaries. Over months of cross-training, Duckworth turned his troops into disciplined merc soldiers very competent in the strategies and tactics of beach landings, air strikes from sea to land and amphibious warfare. Commodore Duckworth takes on jobs that no other merc unit can handle, including attacking coastal forts and hideouts, to bringing pirates, raiders, bandits and other blackguards to justice. **Alignment:** Scrupulous. **Attributes:** I.Q. 18, M.E. 11, M.A. 12, P.S. 20, P.P. 19, P.E. 14, P.B. 12, Spd 14. **Experience:** 12th level Privateer.

Captain Patterson, Quick Stats: Patterson serves as Duckworth's amphibious assault team leader. He is a tough merc from Texas who was actually hired by the Coalition to help train the first class of CSN Naval Infantrymen. He was well compensated for that job, and used the money to move north to the Manistique Imperium. Patterson, a hard drinker and heavy gambler, blew through his nest egg in less than a year. Luckily, a friend in the IMCN told him about Samuel Duckworth and his plans to put together a privateer company specializing in amphibious warfare. Patterson submitted his professional resume, (probably the only merc on Earth to get a job that way) and was instantly accepted. He served as Duckworth's top drill sergeant during the company's formation, and is now the commodore's eyes and ears on hostile shores. **Alignment:** Anarchist. **Attributes:** I.Q. 15, M.E. 10, M.A. 11, P.S. 21, P.P. 20, P.E. 18, P.B. 10, Spd 18. **Experience:** 10th level Special Forces.

Captain Champlain, Quick Stats: Ex-Free Quebec Navy and one of the company's most experienced sailors, Captain Champlain is typically in command of the *Shorehammer*, the company's Harbinger mothership. He keeps enemy ships away from the landing forces and hunts down pirates and sea monsters when the company is assigned to work out on open water. **Alignment:** Scrupulous. **Attributes:** I.Q. 18, M.E. 14, M.A. 11, P.S. 13, P.P. 15, P.E. 12, P.B. 15, Spd 14. **Experience:** 9th level CS Navy Sailor.

Shore Assault Complement: 160 infantry soldiers of various O.C.C.s, including 15 Wilderness Scouts, 20 Juicers, 40 Special Forces and 10 Headhunters. They are led by **Captain Casey Michels**, 8th level Crazy, Scrupulous.

Air/Water to Land Strike Force: 40 flying power armor units, mostly Flying Titan power armor, Red Hawks and Blue Hawks. Led by **Commander Michael Kyle Rose**, 9th level Robot Pilot, Scrupulous.

Air Complement: 32 Merc Soldiers piloting aircraft and power armor, led by **Lieutenant Russell Lenhares**, 9th level Vagabond aircraft pilot, Scrupulous, with the skills Pilot: Airplanes, Combat Helicopter, Hovercycles/Rocket Bikes, Jet Packs and Motor Boats.

Naval Compliment: 80 sailors, gunners and crew for the company's ships. They are led by **Lieutenant D. Vroman**, 9th level Merchant Marine, Scrupulous.

Non-Combatants: Approximately 300 support personnel live in Menominee. This includes family members as well as repair technicians, training staff and medical experts.



The Patrol

A single mercenary company is tasked with security for the vital port city of *Escanaba*. It is deemed too big of a job and too important to preoccupy the energy of the *Loss Prevention Office*, who would be overwhelmed trying to screen new shipments and visitors and patrol the packed city. Instead, the LPO focuses on the special ops and defense of the NG corporation, letting mercs hired by the IMCN do the day-to-day work of assisting Ishpeming Police and protecting the city from bandits, pirates and raiders. The current contract holders are a mercenary company known as **the Patrol**. They have held the position for more than a decade and at this point, have become highly specialized at their current duty. Unlike mercenaries prepared for field duty, the Patrol look more like police or paramilitary troops. While some are clad in power armor and pilot giant robots, because the Patrol helps to keep the peace, patrolling the city and warehouse districts vigilant for thieves, bandits and raiders, they all wear the same stylish uniform, use light and medium body armor, and drive patrol cars and hovercycles. In fact, the people of Escanaba like to tease and call them Police 2.0 – a term of endearment, really, as the Patrol has a stronger presence than the local police force. Of course, unlike police who focus on crime, the Patrol is prepared for all forms of combat, including fighting monsters and demons, both of which are, thankfully, a rarity in Escanaba. And they are efficient and good at their job.

The Patrol is under the oversight of **Colonel Neil Granning**. He is a former Lawman from the New West who understands how to deal with the rough and tumble types who frequent the city. He fell in with the mercenaries in the course of his adventures, and over time, became the leader of the group. His mercenary company stopped in Escanaba to reequip and learned of the upcoming bidding session for the Escanaba defense contract. It was widely rumored at the time that Northern Gun was unhappy with the current contract holders and their inability to keep the docks in Escanaba quiet and running smoothly. Granning convinced his comrades in arms that this was a safe, lucrative opportunity, and that his experience and knowledge would give them a leg up. He instructed the mercenaries in basic law and police-style procedures and conduct, and the disciplined group made a

very good impression at the bidding session, especially considering their last-minute appearance at the negotiating table.

Colonel Granning's company won the contract and renamed themselves **the Patrol** to try to sound more "urban friendly." They painted all their gear and equipment in dark blue with white accents and settled in for the mostly non-battlefield job. Colonel Granning functions as the company's leader, drill sergeant, tactical expert, and father figure. He is loved and trusted by his men and the citizens of Escanaba, and his troops will follow him into Hell and back if asked to do so. The mercenaries in the Patrol are likewise, a trusted and respected part of the landscape of Escanaba.

The Patrol is known for its professionalism, integrity, courtesy, and efficiency at keeping the peace and handling fellow mercs and sailors. That latter part about handling mercs and sailors includes ruthless beatings handed out to violent offenders, suspected pirates and raiders, and those who threaten or molest women and children. The Patrol is not afraid to dish out physical punishment at its own discretion, yet at the same time are surprisingly fair and understanding – and downright gentle to the citizens. Drunkenness, sales disagreements, public disturbances, all of these can be resolved with patience and understanding, and that's usually how the Patrol handles them. The only thing that really sets the Patrol off is violence and cruelty. Escanaba had a reputation for years as a rough-and-tumble port where sailors, pirates and mercenaries got into fistfights in seedy, smoke-filled saloons, dueled in the streets, bushwhacked adventurers and accosted the locals, especially women. The Patrol has put a stop to this. Sure, it still happens from time to time, but heaven help the perp when the Patrol catches up with him – and they will.

Northern Gun has invested a lot of money in the downtown district and goes to great lengths to keep it clean and safe. Brawls outside of downtown may go unnoticed or be responded to in a lazy fashion, but fighting downtown and at the docks instantly draws the attention of the Patrol. When suspects are apprehended guilt is not a priority and *everyone* involved is sure to get bruised by Patrol mercs before being tossed into jail cells to cool down. The Patrol has found that Escanaba regulars quickly learn that a drunken altercation gets a stern verbal warning along with a swift and brutal reprisal at the docks, downtown and in the warehouse districts. However, they realize "boys will be boys," and once tempers cool and tough guys show the law its proper respect, charges are seldom pressed, provided the perps make full restitution for any damages.

Murderers, kidnapers, rapists, abusers of children and women, and the perpetrators of other brutal crimes, are dealt with severely and usually with the barrel of a gun. It is interesting to note that pirates, raiders, slavers, practitioners of dark magic and even the most vile Black Marketeers are treated with the same disdain and violence. Many never get to trial because they are shot dead resisting arrest or simply vanish. While this may sound harsh and perhaps even immoral, the Patrol's tactics have tamed the docks and bars, and keep the streets and neighborhoods safe. The members of the Patrol always try to make certain the lowlifes they target are indeed, guilty before functioning as judge, jury and executioner. If there is doubt, the suspect will be sent to trial.

The Patrol

- A. Sponsorship: Independent.
- B. Outfits: Specialty Clothing. 20 points.

- C. Equipment: Electronic Supplies and Good Gear, Medical Equipment. 15 points.
 - D. Vehicles: Combat Cars. 20 points.
 - E. Weapons: Advanced Weaponry. 20 points.
 - F. Communications: Deluxe Communications Network. 25 points.
 - G. Internal Security: Tight. 10 points.
 - H. Permanent Bases: Fortified Headquarters. 20 points.
 - I. Intelligence Resources: Special Military Operatives. 10 points.
 - J. Special Budget: Small Potatoes. 15 points.
 - K. General Alignment of Personnel: Unprincipled and Scrupulous. 7 points.
 - L. Criminal Activity: None. 0 points.
 - M. Reputation/Credentials: Known. 10 points.
 - N. Salary: Excellent Salary. 20 points.
- Total Points Spent: 192
Size & Orientation: Free Company.

Company Strategy & Tactics. The Patrol deploys its officers in pairs to patrol the City of Escanaba. They have three SWAT units who rotate in eight hour shifts, ensuring a quick response to any degree of crime, any time of day. The company uses its Crisis Response Vehicles as ambulances and SWAT vans, and sometimes assigns one to the crime scene investigation unit. The company even has an Echelon hovertank that they use for the most dangerous standoffs and vehicle pursuits. Colonel Granning has patterned the Patrol after a pre-Rifts metropolitan police force, and has done a fine job of things considering the limitations he must work under.

Company's Colors and Banners: A black and white striped shield with a gold crown in the center.

Standard Issue Weapons:

Side Arm: NG-33 Laser Pistol and NG-T6 Taser.

Primary: NG-LP25 Laser Pulse Submachine-Gun.

Body Armor: NG-A15 Peacekeeper.

Other: Utility belt, flashlight, riot baton/billy club, pepper spray/mace, 4 tear gas grenades, 2 pairs of M.D.C. handcuffs, 1D4x10 zip ties, 6 road flares, walkie-talkie.

Notable Ground Vehicles:

- 16 Gladius exoskeletons.
- 4 Defender power armor suits.
- 4 NG XF-103 Firefighter power armor suits.
- 4 Samson power armor suits.
- 8 NG Prowler hovercycles.
- 20 NG Urban Patrol hovercars.
- 4 NG Crisis Response Vehicles.
- 2 Shortsword combat hovercraft.
- 1 Echelon hovertank.

Notable Naval Vehicles:

- 8 Windshark hovercycles.
- 2 Harbormaster missile boats.

Notable Personnel within the Patrol:

Colonel Neil Granning, Quick Stats: As the leader of the Patrol, Granning is well versed in the law and law enforcement. He is continually molding the Patrol's mercs into suitable peacekeepers. His plan is to specialize the Patrol enough that they can procure a long-term, multi-year contract to protect Escanaba, or maybe even a promotion to replace the Ishpeming city guard. Until then, Granning runs his company fair and square, enforcing

Ishpeming's laws to the letter and cracking down hard on officers who accept bribes and other forms of corruption. He knows that the Trade Council and the Loss Prevention Office pay close attention to Escanaba and will replace the Patrol in a second if they think that there is a risk of them becoming corrupt and endangering the highly profitable market zone that is MercBay. **Alignment:** Scrupulous. **Attributes:** I.Q. 15, M.E. 13 M.A. 19, P.S. 21, P.P. 20, P.E. 15, P.B. 10, Spd 14. **Experience:** 10th level Lawman.

Lt. Deanna Shaw, Quick Stats: Shaw is the Patrol's chief investigator. Most of the crimes the Patrol deals with are cut and dried: bar fights, crimes of passion, theft, smuggling, murder. Occasionally, however, mysteries pop up that require more than just standard police work. Lt. Shaw and her unit of trained Detectives take over for high-profile murders and similar crimes. Part of that unit includes four crime scene investigators for times when science is necessary to solve the case. **Alignment:** Principled. **Attributes:** I.Q. 20, M.E. 14, M.A. 11, P.S. 10, P.P. 15, P.E. 14, P.B. 15, Spd 18. **Experience:** 8th level Lawman/Detective/Investigator. **Psionics:** A Major Psychic with 59 I.S.P. and the abilities of Empathy (4), Meditation (0), Mind Block (4), Object Read (6), See Aura (6), Sense Evil (2), Sense Magic (3), and Sense Time (2).

Jailer Salinger, Quick Stats: This gent runs the Patrol's holding facility. In his seventies now, he is still adept at differentiating between dangerous individuals and those who have simply had too much to drink. Salinger can talk down violent offenders until they become calm and is as good at listening to someone's problems as he is at cracking skulls when a suspect injures one of his officers. He is a big, physically intimidating man who is more than a match for most of the perps who pass through the Patrol's jailhouse. **Alignment:** Anarchist. **Attributes:** I.Q. 12, M.E. 10, M.A. 9, P.S. 22, P.P. 13, P.E. 14, P.B. 10, Spd 8. **Experience:** 6th level Bounty Hunter.

Standard Patrolmen: 96 Police Officers assigned in pairs, including 16 Psi-Stalkers and 4 Dog Boys. The patrolmen are managed by **Sergeant Daniel "Ogre" Thomas**, 9th level Merc Soldier, Scrupulous.

SWAT Unit: 36 Special Forces Soldiers and Robot Pilots split into three teams. Typical equipment consists of NG Gladius exoskeletons, NG Samson power armor and Stalker body armor suits. The squad's leader is **Captain Joseph A. Yerger**, equivalent to a 10th level Robot Pilot, Scrupulous. The squad's top hostage negotiator is **Sgt. James Lukow**, 7th level Mind Bleeder, Unprincipled. The squad's top gun is **Sgt. John Guibert**, 8th level Psi-Slinger from the Pecos Empire, Unprincipled.

Investigation Unit: 14 Detectives/Investigators, headed by **Captain Thomas Molen**, 8th level Military Specialist, Unprincipled, with skills related to investigation, intelligence and interrogation. He is also a Minor Psychic with 42 I.S.P. and the abilities of Clairvoyance (6) and Object Read (6).

Jail Staff: 14 Police Officers who only work in the criminal lockup and holding cells.

Non-Combatants: Crime Scene Investigation Unit: 8 field technicians and 8 laboratory staff. The head of the CSI staff is **Doctor Joe Oertly**, 8th level Rogue Scientist with the skills Crime Scene Investigation, Forensics, Pathology, Medical Doctor, Chemistry and Chemistry: Analytical.

Motor Pool: 12 Operators who maintain the company's vehicles along with between 10 and 20 assistants. The head of the motor pool is **Major Evan Odensky**, 9th level Operator.

The NG Bounty Registry

The largest collection of bounties, rewards and open mercenary assignments in North America is the **Northern Gun Bounty Registry**. The Registry is open to *all mercenaries* regardless of their homeland, political affiliation or species, and any potential client who can access the Registry is free to post jobs and assignments.

For mercenaries, Freelance Spies, Bounty Hunters and assassins, the Registry is a giant list of “help wanted” posts. There are jobs of every type and of every size, from making single individuals disappear to clients looking to hire forces for all-out wars. Desperate mercs may accept less than realistic jobs simply because no one else was willing to risk them or maybe because they have special skills or inside connections they can use to their advantage.

For clients, the **NG Bounty Registry** is one of the few reliable ways to spread the word to various contractors, mercenaries and hit men. The **MercOps Network** is happy to provide a similar service, but many northern customers have difficulty connecting with the central office in **MercTown**. The MercOps Network and the NG Bounty Registry also exchange information frequently, sharing contracts and bounties with each other in an effort to connect more clients with warriors for hire.

Most of the jobs on the Registry are down to earth and realistic, though some are just wishful thinking, like the standing price of one billion credits *Lord Dunscon* has placed on Emperor Prosek’s head. The Registry officials continually remove that listing, but Lord Dunscon seems to find someone to repost it for him every few weeks. There are pirate groups, monster havens and bandit camps all targeted for destruction, and in some places there are general bounties on the heads of Xiticix, vampires, Simvan Monster Riders, other D-Bees and even Coalition soldiers.

Standard Bounty Registry Rates

Note: Where there is a range of payment rates, pay varies depending on the value and level of importance and immediacy, as well as how much the seller knows about the true value of what he has. For example: If the merc or adventurer has acquired information, a prisoner or goods that are worth 100,000 credits, but doesn’t realize it, and asks for much less, say 20,000 credits or even a few thousand credits, the NG representative or authorities are likely to pay him the amount he *has requested* – NOT the full bounty. Actually, in many cases, the NG rep may haggle, suggesting the information, goods or prisoner is not that desirable and offer him half of the asking price – even if they are already getting a tremendous bargain. If the seller holds out, he is likely to get his asking price, provided it is really worth what he’s requesting. Smart and fair NG reps and authorities (which are many) who realize they are getting a bargain will compliment the individual or group for a job well done and pay him/them a bonus, typically 10-40% more than the merc’s *asking price* (not the true value). Regardless of the seller’s savvy, NG reps and authorities NEVER overpay and may refuse to do business with someone they feel is trying to blackmail them, is working for a rival or enemy, or who is insulting and disrespectful.

There are exceptions to every rule, so there is the occasional bounty that exceeds those listed below.

Common Rates for NG Bounties and Merc Services:

Anti-Bandit Patrols: 500-2,000 credits per week.

Anti-Pirate Patrols: 1,000-2,500 credits per week.

Assassination – Low Value Target: 10,000 credits.

Assassination – High Value Target: 50,000+ credits.

Assassination – Political Leader: 500,000+ credits.

Assassination – Powerful Supernatural Target (Demon Lord or Warlord, Lesser God, Alien Intelligence, etc.): 500,000+ credits.

Assassination – Powerful Creature of Magic (Adult or Ancient Dragon, etc.) or Monster (Splugorth Slaver, etc.): 500,000+ credits.

Combat Strike, Small Military Target/Group: 50,000-200,000 credits. Small Military Target: 20-60 hostiles or 6-12 robots, power armor or armored vehicles, or a Greater Demon or dragon hatchling and 2-8 henchmen/minions.

Combat Strike, Medium Military Target/Group: 350,000-1.2 million credits. Medium Military Target: 20-40 all or mostly robots and/or power armor, or 100-300 troops with a few armored combat vehicles/robots, or an adult dragon or 1D4 Greater Demons and a dozen or two henchmen or fighters.

Combat Strike, Large Military Target (Company to Battalion-Sized): 4-16 million credits. Large Military Target: 80-160 all or mostly robots and/or power armor or demons, or other tough force, or 300-600 troops with some armored combat vehicles/robots or magic.

Combat Strike Note: In all cases, a Northern Gun rep or Ishpeming authority will provide clear identification of the target and the last known coordinates of its location. A Combat Strike is a devastating strategic military attack intended to “remove” another military force. Such targets include the well armed and armored combat force of a known enemy, hostile mercenaries, or heavily armed and hostile D-Bees, pirates, bandits, raiders, Minions of Splugorth, Horune, Simvan Monster Riders, Brod-kil, Xiticix, demons, monsters, practitioners of magic engaged in military ops or raids, Naruni engaged in any operation, and similar threats.

A *successful Combat Strike* is utterly destroying the target (preferred), or destroying half and dispersing the rest (acceptable). Dispersing the remainder of a hostile force means sending the enemy fleeing for their lives with little likelihood of regrouping and returning, and forcing them to abandon gear and valuables. In some cases, the contractor may require the hired mercs to chase down and eradicate the enemy force in retreat, or to wait a few days and search out and destroy any who are trying to regroup.

Payment is made to a group only upon confirmation of success. If any sizeable portion of the enemy force (33% or more) was “dispersed,” half of the payment is held in escrow for 120 days to insure they were scared off and do not return. If the target returns with reinforcements and an eye for vengeance, the hired guns forfeit the money held in escrow unless they immediately readdress the problem and deliver a permanent solution.

Nothing is paid for failure regardless of the losses suffered by the hired guns.

Any salvage and booty left behind by the enemy force is a bonus for the hired Strike Force. Whatever the Strike Force does not claim and remove from the battlefield after 72 hours is fair game for recovery by NG, Ishpeming or anyone else. In reality, scavengers usually show up within 1D6 hours after the battle and

they will start to loot a battle scene unless a force is left to patrol and protect it.

Fugitive Recovery – Low Priority: 2,000-8,000 credits.

Fugitive Recovery – Medium Priority: 6,000-36,000 credits.

Fugitive Recovery – High Priority: 30,000-120,000 credits.

Fugitive Recovery – Most Wanted: 100,000-600,000 credits.

Garrison Duty – Short-Term: 750 credits per week.

Garrison Duty – Long-Term: 1,000 credits per week.

Information Gathering – Word on the Street: 200-1,200 credits.

Information Gathering – Sensitive Data: 2,000-24,000 credits.

Information Gathering – Industrial Secrets: 2,000-120,000 credits.

Information Gathering – State Secrets: 24,000-200,000 credits.

Monster Pest Control: 2,000-20,000 credits per monster, depending on its ferocity and toughness.

Police Duty – Short-Term: 900 credits per week.

Police Duty – Long-Term: 1,250 credits per week.

Police Duty – Special Operations/Undercover: 2,000 credits per week.

Sabotage Mission – Creates Inconvenience/Warning: 2,000 credits.

Sabotage Mission – Minor Property Damage and/or Short Work Stoppage: 4,000-8,000 credits (5D6 hours).

Sabotage Mission – Undercover Ongoing Sabotage: 2,500 credits per week to cause delays, uncertainty, infighting, dissension among the ranks and similar things that have a negative impact.

Sabotage Mission – Commando Raid: 250,000-950,000 credits, massive destruction and long-term shutdown of operations (3D4x10 days) or destruction or theft of valuable prototype, or destruction or murder of key personnel that causes a shutdown.

Shipment Escort/Protection Through Hostile Territory: Same as Interception, below.

Shipment Intercept – Small: 2,000-12,000 credits.

Shipment Intercept – Medium: 10,000-40,000 credits.

Shipment Intercept – Large: 30,000-120,000 credits.

Vampire Hunting: 5,000-20,000 credits per set of vampire fangs.

Other Common Bounties

The Crime, Average Bounty, Typical Sentence

Note: Gathered from **Rifts® Merc Ops**.

Assault: Armed (Use of a Deadly Weapon): 1,000-25,000 credits (dead or alive) – 1-8 years imprisonment.

Assault: Felonious (With Intent to Kill): 5,000-50,000 credits (dead or alive) – 5-15 years imprisonment. May involve the use of magic or psionics.

Assault: Unarmed: 2,000-10,000 credits (alive) – 6 months to 2 years of imprisonment.

Arson or Sabotage (Deliberate, Massive Damage to Property): 2,000-250,000 credits (dead or alive) – 8-20 years imprisonment, life or execution if people died as a direct result of said criminal act.

Cyber-Snatcher: 5,000-50,000 credits (dead or alive) to bring a Cyber-Snatcher to justice. Cyber-Snatching sentences:

3-12 years imprisonment for robbery without killing. 15 years to life or execution for committing murder in the process of Cyber-Snatching, which most Cyber-Snatchers do. **Note:** The sentence depends on the severity of the crime and the number of victims. Cyber-Snatching typically involves mutilation and murder. Sadly, this is a crime that is often overlooked on the mean streets of high-tech cities, despite the level of violence. In other cases, the perpetrator is charged with multiple counts of first degree murder. Cyber-Snatchers are often dealt with outside the law (i.e. a bounty for “dead”) with bounties sponsored by private individuals, family members and vigilante groups.

Cybernetic Body-Chop-Shop Operations: 2,000-75,000 credits (alive) – One to 8 years imprisonment for running or participating in the operation of an illegal cybernetics ring that buys, sells and installs stolen and/or defective used bionics and cybernetics. Another crime that is frequently ignored by the law.

Cyber-Smuggling (Black Market Contraband): 1,000-25,000 credits (alive) – One to 6 years imprisonment for buying, selling, trading, smuggling and installing illegal, Black Market cybernetics. Another crime that is frequently ignored by the law.

Contraband: Alien Technology (dangerous or illegal): 10,000-100,000 credits (dead or alive) – 2 to 10 years imprisonment (death in the CS).

Contraband: Books & Historical Documents: 1,000-50,000 credits (alive) – 1-5 years imprisonment (death in the CS).

Contraband: Drug Production & Smuggling: 20,000-100,000 credits (dead or alive) – 5-10 years imprisonment.

Contraband: Demons/Dangerous Animals: 20,000-200,000 credits (dead or alive) – 6-30 years imprisonment (death in the CS).

Contraband: Magic – 50,000 to 100,000 credits (dead or alive) – 5 to 15 years (death in the CS).

Contraband: Pre-Rifts Artifacts (or forgeries of artifacts): 1,000-50,000 credits (alive) – 1-8 years imprisonment (death in the CS).

Contraband: Slaves: 5,000-50,000 credits (dead or alive) – 10-20 years to life.

Contraband: Weapons: 10,000-100,000 credits (dead or alive) – 5-15 years to life (death in the CS if weapons are alien technology or magic based).

Contraband: Weapons of Mass Destruction: 100,000-1 million credits (dead or alive) – execution or life imprisonment (death in the CS).

Extortion/Blackmail: 25,000-250,000 credits (dead or alive) – 10 to 20 years imprisonment.

Espionage, State (Stealing Government Secrets): 500,000-5 million credits (dead or alive) – execution or life imprisonment.

Espionage, Industrial (Stealing Proprietary Information): 25,000-5 million credits (dead or alive, but usually alive) – 5-15 years imprisonment or Mind Wipe, plus possible civil action for restitution.

Forgery, Currency/Credits: 5,000-50,000 credits (alive) – 10-25 years imprisonment.

Forged Documents: 1,000-10,000 credits (alive) – 1-4 years imprisonment.

Forgery, Identity Documents: 5,000-50,000 credits (dead or alive) – 3-12 years imprisonment (death in the CS if the papers/IDs were to get into a fortified city like Chi-Town).

Forgery, Pre-Rifts Artifacts: 1,000-50,000 credits – 1-8 years (a beating and destruction of property to death in the CS).

Illegal Augmentation/Genetic Manipulation: 10,000-200,000 credits (dead or alive) – 15-30 years, possibly execution (death in the CS). **Note:** Double the bounty and the punishment if it involves kidnapping and experimentation against the subject's will.

Impersonation: Of police, NG authority or business leader, NG or CS military personnel, NG political figure, NG Sales Rep or any agent of Northern Gun – 10,000-100,000 credits (dead or alive; typically alive) – 5-10 years imprisonment, possibly life or execution (death in the CS).

Kidnaping: 20,000-80,000 credits (alive) – 10-20 years imprisonment; reduced or suspended sentence is possible due to extenuating circumstances.

Man-Eater, Feeding on Human Flesh or Blood: 10,000-60,000 credits (dead or alive) – 10 to 20 years imprisonment (death in the CS).

Manslaughter: 5,000-10,000 credits (alive) – 2-8 years of imprisonment; reduced or suspended sentence is possible due to extenuating circumstances.

Mass Murder: 250,000-5 million credits (dead or alive) – execution. Typically involves the murder or attempted murder of dozens to hundreds, sometimes thousands of people, and may include terrorists and cultists. Also see Genocide.

Mass Murder, Genocide: 250,000-20 million credits (dead or alive) – execution. Genocide usually involves the systematic extermination of a particular people based on race, occupation, religion or beliefs and involves the murder or attempted murder of hundreds, thousands or millions of people.

Mind Control, Psionics (Misuse of Psionics): 15,000-200,000 credits (dead or alive) – 2-12 years (double in the CS, loss of citizenship and expulsion out of the fortified cities). **Note:** Includes using psionic abilities in a crime that involves altering or eliminating a person's memories, mind control and mental manipulation, harassment (bad dreams and illusions) and similar acts of mind control or mental torture.

Mind Control, Magic: 20,000-250,000 credits (dead or alive) – 2-8 years (death in the CS). **Note:** Using magic to charm, dominate, enslave, mind control, or torment one's victim, includes the use of illusions.

Murder, Attempted: 5,000-75,000 credits (dead or alive) – 5 to 15 years. **Note:** Includes attempted assassinations and criminal hit attempts. Bounty varies depending on who the criminal tried to kill and their place in society.

Murder, First Degree: 25,000-500,000 credits (dead or alive) – execution or 25 years to life. **Note:** Includes assassinations and hits for hire.

Murder, Second Degree: 10,000-150,000 credits (dead or alive) – 15 years to life.

Murder, Serial Killer: 10,000-250,000 credits (dead or alive) – execution or life imprisonment. **Note:** A serial killer is someone who regularly targets specific individuals, usually one at a time, for murder over a period of time.

Negligent Homicide (Accidentally Killing Another Person): 5,000 to 50,000 credits (alive) – 1-4 years; reduced or suspended sentence is possible due to extenuating circumstances.

Racketeering (Most Organized Crime Operations) – 10,000 to 250,000 credits (alive) – 10 to 20 years imprisonment. **Note:** Includes protection rackets, numbers running, money laundering, and most criminal operations that have a network of agents and operatives or involve a criminal organization that extorts and handles money.

Resisting Arrest – 500 to 5,000 credits (alive) – 1 to 2 years imprisonment, plus fines. A reduced or suspended sentence is possible for first-time and youthful offenders, or due to mitigating circumstances. *Also see Suspect.*

Robbery, Armed – 5,000 to 25,000 credits (dead or alive) – 5 to 20 years imprisonment.

Robbery, Bank – 10,000 to 50,000 credits (dead or alive) – 20 years imprisonment.

Robbery, Horse/Cattle Rustling – 5,000 to 30,000 credits (dead or alive) – 2-12 years imprisonment.

Robbery, Unarmed – 1,000 to 5,000 credits (alive) – six months to 4 years imprisonment.

Sex Crimes – 25,000 to 150,000 credits (dead or alive) – 1 to 25 years depending on the type of crime.

Slaving – 10,000 to 75,000 credits (dead or alive) – 10-20 years imprisonment, death in some communities. **Note:** The practice of capturing sentient life forms (humans, D-Bees and others) for resale against their will as slaves, or trading in such slaves.

Suspect Wanted for Questioning – 1,000 to 100,000 credits (alive) – wanted for questioning or further investigation; criminal charges may be made at a later date.

Smuggling: 10,000-100,000 credits (alive) depending on what is being smuggled and who is placing the bounty.

Terrorism Using Summoned or Controlled Monsters/Demons/Animated Dead (namely Shifting/Summoning or Necromancy): 10,000-250,000 credits (dead or alive) – 10 to 30 years imprisonment (death in the CS). **Note:** Includes raids on villages, supply depots, and transport vehicles using monsters.

Treason: 100,000-2 million credits (dead or alive) – court martial if military treason and execution or life imprisonment.

Using Monsters or Animated Dead in the Commission of a Crime – 5,000-150,000 credits (dead or alive) – 5 to 20 years imprisonment (death in the CS). **Note:** Includes raids on towns, supply depots, and transport vehicles and, in effect, using monsters to intimidate or rob – fundamentally the same as an armed robbery.

Vandalism: Typically on a large scale or serial basis – 1,000 to 10,000 credits (alive) – 4 months to two years imprisonment, plus fines and restitution; a reduced or suspended sentence is possible for first-time and youthful offenders, or due to mitigating circumstances.

Notable Bounties Wanted *Dead Only*

– applicable only to *select* wilderness communities

50 credits per head of a Xiticix.

100 credits per head of a Brodkil or Gargoyle (Simvan included in the New West and by the CS).

200 credits per head of a Mega-Damage monster.

500 credits per head of a Black Faerie or Witchling.

2,000 credits per head of a Daemonix (CS).

1,000 credits per head of a demon or Dyvalian.

2,000 credits per head of a supernatural monster.

3,000 credits per head of a were-creature.

100-300 credits per Wild Vampire (Southwest).

300-1,000 credits per Secondary Vampire (Southwest).

10,000 credits per head of a Naruni/Uteni Alien or Molock (CS).

50 million credits for the head of Lord Dunscon (CS).

Northern Gun O.C.C.s

Bush Pilot
Loss Prevention Officer
Monster Responder
Police Officer
Robot Control
Sales Representative

NG Bush Pilot O.C.C.

Getting shipments to remote mining sites, mercenary camps, and war zones (not to mention pirates, criminals and resistance movements) requires a special kind of pilot and cargo hauler. Just any driver or merc won't do. It requires someone who thrives on danger and laughs in the face of the unknown. Someone willing to brave the uncharted wilderness, ignore borders and enter war zones. Someone who regards the cargo they are hauling and the vehicle they are piloting as their own even when it's not, and isn't about to let it get hijacked without a fight. That "someone" is the *Northern Gun Bush Pilot* – part Wilderness Scout, part Operator, part gun toting Merc Soldier, and part race car driver or stunt pilot with nerves of steel. And Northern Gun employs a small army of them.

Bush Pilots may operate ground vehicles or aircraft, boats or robots, or all of the above. Most are skilled airmen who are accustomed to operating without runways or even landing strips, who use hovercraft and helicopters and sheer bravado to fly in and out of dense woods, are able to compensate for unpredictable takeoff and landing conditions, and are willing to fly through a hail of gunfire or defy hostiles to make their delivery. While this may sound like a job for mercenaries and other men-at-arms or adventurer types (and any of them with the skills and guts can do the job), Bush Pilots are a special breed of adrenaline addicted, thrill-seeking daredevils who live for each new, death-defying challenge. For many Bush Pilots, "the job" is often not so much about the pay (which is often very good), but the personal challenge. Say the words "impossible" or "suicide mission" and the Bush Pilot is intrigued.

Out of necessity, Bush Pilots are incredibly resourceful and willing to break rules, disobey laws and take risks most sane people would never consider. While they are usually decent to excellent fighters, combat is NOT what the Bush Pilot is looking for. Their only goal is to deliver their cargo (or passenger) in one piece and on time. Almost everything they do involves making that delivery – getting in, dropping off and getting out – and enhancing their reputation. Of course, living to tell about it is also important.

Bush Pilots are particularly famous for their actions in and around the Xiticix Hivelands and during the Siege on Tolkeen. The Xiticix are a significant airborne threat, and only the craziest and most determined pilots risk doing an overflight in bug territory. At Tolkeen, Bush Pilots helped supply anti-Coalition guerrillas and continue to do so on several battlefronts. They also do work for the Black Market and are an intrinsic part of many smuggling operations.



Ironically, most Bush Pilots try to avoid politics or taking up a cause. They try to stay impartial. Each assignment is a new challenge. Their only goal: Making the delivery and getting out alive. As a result, the same Bush Pilot may end up working for both sides in a conflict, depending on who hires them and when. However, most avoid working for monsters, demons and true evildoers.

Northern Gun's cadre of Bush Pilots are used to keeping supply lines open during winter and service the many, otherwise

inaccessible frontier towns, logging camps, communities and war zones that rely on Northern Gun for goods. Sometimes the company also uses Bush Pilots to discreetly deploy units of Loss Prevention Officers (LPOs) or mercenaries without anyone being the wiser. With a decent plan and a good pilot, a small strike force can appear and disappear before any kind of counterattack can be mounted. This is especially useful when Northern Gun is striking at competitors or Black Marketeers that have gotten out of hand and wants to make the attack appear random or the work of an outside third party.

Special Abilities of the Northern Gun Bush Pilot O.C.C.:

1. Can Pilot Anything. If they can figure it out, Bush Pilots can drive, pilot, and fly just about any vehicle, even if unfamiliar with it, at a base skill of 50%. This percentage does NOT improve with experience and reduce their usual piloting and stunt bonuses by half when piloting a vehicle they do not have a skill in.

2. Short Takeoffs and Landings: Bush Pilots are skilled enough and know tricks to take off and land with a minimal amount of space. A Bush Pilot without a VTOL (Vertical Takeoff and Landing) aircraft can get his or her aircraft to land or airborne in 50% of the normal necessary runway distance; 75% for large aircraft like the Broadwing cargo plane or Air Castle bomber. Many also customize their aircraft to make it easier to pull off such stunts.

3. Emergency Landing Expert and Stunt Bonuses: Many of a Bush Pilot's landings seem like emergency landings, even some that are planned ahead of time. Dealing with extremely rough and difficult ground conditions and landing places that seem impossible for any other pilot is a big part of what makes them Bush Pilots. **Bonuses:** +25% on all emergency landing rolls, +10% on all evasive maneuvers and stunt piloting, +1 on initiative and +2 to strike and dodge with a vehicle when driving any for which the pilot has a skill and familiarity, +2 to roll with impact, and +10% to save vs coma and death (some Bush Pilots have more luck than brains).

4. Bad Weather: In Canada and the Northern United States, fierce lake storms, squalls, and winters can make flying a nearly impossible task. However, even in bad weather, mercenaries and remote communities still call for vital equipment and supplies. All weather penalties are reduced by 50% for Bush Pilots.

5. Special NG Bush Pilot Armored jumpsuit. Not an ability, but standard equipment for most Bush Pilots. The flight suit is made of a resilient, M.D.C. micro-fiber fabric with additional M.D.C. padding in the shoulders and chest and padding and plates in the upper and lower legs. Excellent mobility; no movement penalties. Standard is camouflage colors. **Cost:** 18,000 credits at most NG retail outlets.

M.D.C. by Location:

Helmet – 35
Arms (2) – 9 each
Legs (2) – 20 each
Main Body – 25

Northern Gun Bush Pilot O.C.C. Stats

Alignment: Any, but almost always Unprincipled or Anarchist.

Attribute Requirements: I.Q. 9 and P.P. 11 or higher.

Racial Requirements: Most of Northern Gun's Bush Pilots are human (90+%), but there are independent pilots from many D-Bee races.

O.C.C. Skills:

Aircraft Mechanics (+15%)
Automotive Mechanics (+15%)
Basic Mechanics (+15%)
Camouflage (+20%)
Combat Driving
Computer Operation (+10%)
Forgery (+20%; to forge travel documents and cargo manifests, etc.)
Land Navigation (+16%)
Language: Native Language
Language: Other: One of choice (+15%).
Literacy: American
Mathematics: Basic (+20%)
Navigation (+15%)
Parachuting (+10%) or Weapon Systems (+10%)
Pilot: Airplanes (+16%)
Pilot: Boat: Ships (+15%) or Submersibles (+10%)
Pilot: Hovercycles, Skycycles and Rocket Bikes (+10%)
Pilot: Hover Craft (Ground; +15%) or Jet Aircraft (+15%)
Pilot: Truck (+25%)
Pilot: One of choice, any (+12%).
Radio: Basic (+10%)
Wilderness Survival (+10%)
W.P. Modern: One Energy Weapon of choice.
W.P. Energy Pistol or Handguns
Hand to Hand: Basic, but it can be changed to Expert at the cost of one O.C.C. Related Skill or Martial Arts (or Assassin if evil) for the cost of three skill selections.

O.C.C. Related Skills: Select four other skills at level one. Add one additional skill at levels 3, 6, 9 and 12. All new skills start at level one proficiency. These selections get the benefit of any bonuses that may be noted below.

Communications: Any (+5%).
Cowboy: None.
Domestic: Any.
Electrical: Basic Electronics (+10%) only.
Espionage: Any (+5%).
Horsemanship: General only.
Mechanical: Any.
Medical: First Aid or Paramedic (+5%) only.
Military: Any (+5%).
Physical: Any.
Pilot: Any (+15%).
Pilot Related: Any (+10%).
Rogue: Any (but only Roadwise and Streetwise get a +20% bonus).
Science: Astronomy & Navigation (+10%) only.
Technical: Any.
W.P.: Any.
Wilderness: Any (+10%).

Secondary Skills: One Secondary Skill at levels 2, 5 and 8. Selections are made from the Secondary Skill list on page 300 of **Rifts® Ultimate Edition**. These are additional areas of knowledge that do not get any bonuses, aside from any possible bonus from having a high I.Q. attribute. All Secondary Skills start at the base skill level.

Standard Equipment: Northern Gun weapon for each W.P. and four extra E-Clips for each, NG-S2 Survival Kit, light or medium NG body armor of choice, two NG Bush Pilot armored jumpsuits, one mechanic's jump suit, flight helmet with built-in radio and nightvision goggles (may be installed in body armor helmet), parachute, field computer with navigation software, 8 flares, compass, canteen and hiking boots.

Starts with one large truck or aircraft. Aircraft is often a Sky King or Skychadow bush plane, though pilots who work exclusively on the lakes will either have a version with floats installed or use a Kingfisher seaplane. Helicopters, hovercraft and other aircraft are all an option, however, as Northern Gun allows its pilots to use whatever aircraft they personally own/prefer, and they are not restricted to NG models. One Rocket Bike or hovercycle for high-speed smuggling runs, scouting ahead and fast escapes.

Money: Starts with 2D6x1,000 credits. NG pilots are paid upon completion of the job, as are many independent pilots (some demand money up front, but most of these have a known reputation for successfully evading the Coalition, skirting the Xiticix Hiveworlds, etc.). A typical drop into a "hot zone" under likely enemy fire or delivering contraband within a high risk zone (including most Coalition States and the Vampire Kingdoms) pays 10,000-40,000 credits depending on the job and cargo. Moderately dangerous deliveries and smuggling ops pay 3,000-12,000 credits. Simple runs with low expectations of trouble pay 1,000-4,000 credits.

Cybernetics: Bush Pilots will often have 2D4 minor cybernetic implants installed, generally Multi-Optic Eyes, nightvision or other optical enhancements, sometimes Cyber-Disguises and other common items.

NG LPO O.C.C.

Northern Gun's private army of spies, enforcers and specialists are known as **Loss Prevention Officers (LPO)**. While local law enforcement is handled by the Ishpeming and city governments, and often conducted by professional lawmen and hired mercenaries, the corporate side of Northern Gun maintains the *Loss Prevention Office (LPO)* as its own elite, private army. It is the LPO who conduct tactical strikes and intelligence gathering against Naruni Enterprises, and continue to investigate other alien competitors, as well as engage mercenaries and lead most military combat operations for the Northern Gun corporation. Loss Prevention Officers are always used for espionage operations and missions deemed too sensitive, important or secretive to be entrusted to mercenaries or local law enforcement. For this reason, the LPO is also known as **Northern Gun Special Forces** by outsiders.

Loss Prevention Officers (LPOs) have complete authority, answering only to the heads of the Northern Gun corporation and Ishpeming's top political leaders. This makes them arresting officers, commandos, spies, and often the judge, jury and executioners. They can make judgement calls on anything they deem to be a matter of corporate or government security and safety for Northern Gun and the Ishpeming Republic. They can arrest/capture, interrogate and kill criminals who steal from Northern Gun or endanger corporate operations, or the security of the civilian community. Likewise, Black Marketeers and outsiders who

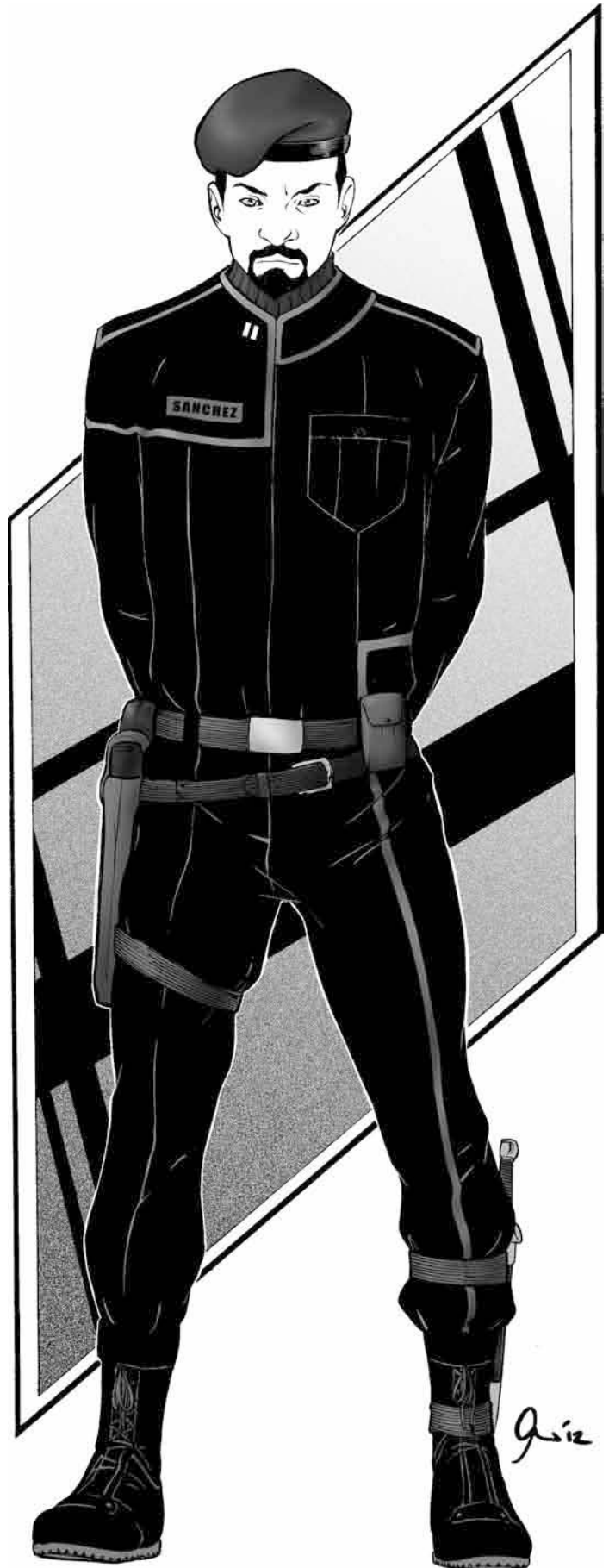

grow large enough to become a threat to profits can also be run out of town or dealt with as if they were criminals. Loss Prevention Officers may also remove troublesome pirates and raiders quietly so as not to dissuade others from visiting Northern Gun or buying goods from the company. And when a prototype or piece of secret NG technology is stolen, the Loss Prevention Office is tasked with finding the thief, dealing with him appropriately, and recovering the stolen goods or secrets. In the past, the LPO have wiped out entire mercenary groups, blown up labs and research institutions, and assassinated Rogue Scientists, Coalition spies, mages and D-Bees alike. Covering their trail is a part of the job, and outsiders are typically unaware that the Loss Prevention Office is looking for them until it is too late.

Despite their incredible level of authority and autonomy, Loss Prevention Officers are notorious for being “boy scouts” loyal to Northern Gun the corporation, the Ishpeming Republic as their nation, and sincerely seeking justice and security. Few LPOs ever try to abuse their authority and most are beyond bribes and corruption. This is due, in large part, to the corporate structure. They must answer to the company bosses, have supervisors, and those who do an outstanding job get rewards for being judicious, fair and expedient. Meanwhile, those who do a poor job, take bribes or show favoritism to powers outside the NG, can expect to get fired or disappear if their crime is too great or they know too much. As a result, LPOs are dedicated and loyal first to the Northern Gun corporation and second to the Ishpeming Republic and its citizens. Most do their job extremely well.

LPOs are stationed at every official Northern Gun city and major commercial center, and have many resources within the Ishpeming Republic, itself. They have access to anything that Northern Gun makes, and can appropriate or commandeer company property when they deem it necessary. Using the vast distribution mechanism of Northern Gun, they often ride along with products or resupply shipments to get to hard-to-reach places and are no stranger to parachuting into remote areas. In the pursuit of their duties, Loss Prevention Officers may pretend to be Sales Representatives, Operators, service personnel, corporate management, IMCN mercs, Ishpeming local authorities or even NG customers, and will stop at nothing to carry out the orders they are given.

Special Abilities of the Loss Prevention Officer O.C.C.

1. Withhold Order: One of the major tools that Loss Prevention Officers use to encourage compliance is the ability to put out a *Withhold Order* on an individual, group or organization. A *Withhold* is a devastating blow to any independent customer or mercenary, as it is, in effect, an official “excommunication” from Northern Gun and its many products and services. Those under *Withhold Orders* have their name and likeness entered into the **NG Blacklist Database** and refused service at any official Northern Gun outlet. *Withholds* also include a *ban* from the Republic of Ishpeming, and those trying to enter the state are arrested once their identity is uncovered. For anyone who relies on Northern Gun and its goods, a *Withhold Order* is a serious obstacle to everyday life. Threatening to invoke a *Withhold* is an effective negotiation tool with mercenaries, privateers, pirates, adventurers, miners, loggers, most independent kingdoms (especially in the Midwest), and anyone else who depends on Northern Gun. Whether or not the LPO can actually make good on the threat is

another matter entirely, but even just the suggestion of a *Withhold Order* is enough to change the atmosphere of any negotiation.

2. Northern Gun Product Familiarity: Loss Prevention Officers are essentially the *special forces* and *secret police* of Northern Gun. Their equipment is exclusively NG (unless disguising their identity), and they have access to all NG gear from a weapon and vehicle pool they have trained with for years. They are accustomed to heavy, tough NG equipment and know how to compensate for its weight or other shortcomings. For more than a decade, the NG Super-Laser Pistol & Grenade Launcher was standard issue for the LPOs, and every member of the organization learns how to use it, submachine-guns and heavy rifles. Loss Prevention Officers face no strength or accuracy penalties when using NG weapons, their P.S. notwithstanding.

3. Northern Gun Distribution Network: In addition to almost unlimited access to Northern Gun products and equipment, LPOs can “ride along” on NG ships and aircraft, hovertrains or other resupply efforts. Sometimes they are parachuted into the field or deployed by submersible or other covert method. One way or another, the LPO can usually arrange transportation for themselves and their party along any regularly used Northern Gun supply route.

4. The Face of Authority: In the Ishpeming Republic, LPOs have a greater authority than the police and any hired IMCN mercs. This means the police and mercs defer to the LPO, obey their orders, share information and follow any LPO who takes charge.

Northern Gun Loss Prevention Officer O.C.C. Stats

Alignment: Any, but 35% are Unprincipled and 40% Scrupulous.

Attribute Requirements: I.Q., M.E. and P.S. of 10 or higher.

Racial Requirements: All *official* Loss Prevention Officers are human.

O.C.C. Bonuses: +1 to P.E., +2 to Spd, +2D6 to S.D.C., +1 on initiative, +2 on Perception Rolls involving espionage, undercover operations, theft, smuggling, terrorism and threats to NG or the community of Ishpeming.

O.C.C. Skills:

Computer Operation (+10%)

Detect Concealment (+10%)

Find Contraband (+20%)

Intelligence (+16%)

Interrogation (+15%)

Language: Native Language (+20%)

Language: Other: One of choice (+10%).

Law (General; +10%)

Literacy: American (+25%)

Mathematics: Basic (+20%)

Parachuting (+10%)

Pilot: Hovercycles (+10%)

Pilot: Hovercraft (+5%)

Prowl (+10%)

Radio: Basic (+10%)

Streetwise (+10%)

Tailing (+15%)

Tracking (people; +10%)

Undercover Ops (+15%)

W.P. Energy Pistol

W.P. Energy Rifle

Hand to Hand: Commando or Martial Arts (or Assassin if evil); pick one.

O.C.C. Related Skills: Select four other skills at level one. Add one additional skill at levels 2, 5, 8 and 11. All new skills start at level one proficiency. These selections get the benefit of any bonuses that may be noted below.

Communications: Any (+10%).

Cowboy: Any.

Domestic: None.

Electrical: Basic Electronics only.

Espionage: Any (+10%).

Horsemanship: Any.

Mechanical: Basic Mechanics only.

Medical: First Aid and Crime Scene Investigation (+5%) only.

Military: Any (+5%).

Physical: Any.

Pilot: Any, including Power Armor skills.

Pilot Related: Any.

Rogue: Any (+5%).

Science: Math and Chemistry only.

Technical: Any.

W.P.: Any.

Wilderness: Any.

Secondary Skills: Two Secondary Skills at levels 2, 6 and 10. Selections are made from the Secondary Skill list on page 300 of **Rifts® Ultimate Edition**. These are additional areas of knowledge that do not get any bonuses, aside from any possible bonus from having a high I.Q. attribute. All Secondary Skills start at the base skill level.

Standard Equipment: Northern Gun rifle of choice, Northern Gun pistol of choice, five extra E-Clips for each, NG-H5 Holdout ion pistol, one NG Power Pack (any type), NG-S2 survival kit, two Loss Prevention Officer field uniforms (black with grey trim and accents), LPO dress uniform, LPO I.D. and credentials, NG body armor of choice, walkie-talkie, night-vision goggles, 2 auditory listening bugs, 1 micro-video camera, field computer, compass, canteen and hiking boots.

In addition, Loss Prevention Officers enjoy virtually unlimited access to the entire range of Northern Gun products, made available upon special assignments, experience and reputation for a job well done within the LPO. Thus, while any device, body armor or personal weapon is theoretically available, including vehicles, weapons, explosives, giant combat robots, and aircraft, such allocations must be deemed justified by the LPO Team Supervisor, one of the LPO Department Heads, or even Chief Callister. Additionally, the Loss Prevention Officer making the request must be on good terms, trusted and deemed to have the experience and disposition to handle especially dangerous and powerful weapons, robots and equipment. *G.M.s, use your discretion.*

Money: Pay is 6,000 credits per month in NGMI credits. Characters start out with one month's pay.

Cybernetics: Loss Prevention Officers often have 1D6+1 cybernetic implants or minor bionics installed. They may also receive bionic or Bio-System replacement parts, paid for by the company, for limbs and organs lost or damaged beyond repair in the line of duty. Otherwise, additional cybernetics and bionics *may* be offered in the form of bonuses and special rewards. ALL bionic augmentation must be authorized by the company, though as many as eight legal, cybernetic enhance-

ments are allowed. Only 4% of LPOs are partial cyborgs and there are no Combat Cyborgs on the force. Augmented warriors such as *Combat Cyborgs*, *Juicers*, *Crazies*, and so on, are hired for special operations as independent, third-party contractors (i.e. mercenaries).

LPO Chief – Andrea Callister (see description on page 20).

Notable LPO Department Heads:

Acquisitions and Recovery – **Michael J. Osborne**, 10th level LPO, Anarchist.

Alien Investigations – **Ed Surrent**, 10th level LPO, Anarchist.

Corporate Assets – **Denny “Kegleneq” Ham**, 12th level LPO, Unprincipled.

Espionage – **Ryan Rawlings**, 11th level LPO, Anarchist.

Intelligence – **Stephen Daniel**, 12th level LPO, Anarchist.

Interrogations – **Doctor Winston**, 10th level Rogue Scientist, Anarchist.

Investigations – **Patrick Le Houllier**, 9th level LPO, Scrupulous.

National Security – **Greg Diaczyk**, 12th level LPO, Scrupulous.

Special Ops – **Jeremy Davis**, 13th level LPO, Unprincipled.

Tactical Strikes & Counter-insurgency – **Ralph Lajara**, 10th level LPO, Scrupulous.

Threat Assessment & Eradication – **Jeff A. Lee**, 11th level LPO, Unprincipled.

Undercover Ops – **Thomas Karras**, 9th level LPO, Unprincipled.

Monster Responder O.C.C.

Unlike animal control of our time, Rifts Earth is pestered by actual monsters, demons, aliens and mutants. Giant footprints, farmers and ranchers who report mutilated or missing livestock, eyewitness reports and photographic evidence all prompt an investigation by Northern Gun's small corps of **Monster Responders**. These specialists are called in whenever a dangerous creature is thought to be living within or near human habitation or coming in from the woods to stalk livestock or worse, human prey.

Dealing with “monsters” is a job that requires military weapons and training, and psionic abilities are a plus. Monster Responders must be part hunter and part soldier, part exterminator and part special forces. They gas, poison, shoot, trap and incinerate monstrous menaces, and use heavy weapons to bring down huge, Mega-Damage beasts. Monster Responder units are on call twenty-four hours a day, and they are often summoned into work during the middle of the night, at twilight or sunrise. They may need to use SCUBA gear or jet packs to accomplish their mission, or call for help from a Northern Gun combat robot or tank unit that can bring additional firepower to the hunt. Monster Responders always share information and coordinate with the police and LPO whenever necessary. They are also likely to lead IMCN Merc Soldiers in raids on monster nests and lairs.

To the citizens of Upper Michigan, Monster Responders are respected heroes who represent the Republic's front-line defense against creatures from the Rifts, demons and alien invaders. As such, they are even more beloved and appreciated than NG law enforcement (though they are respected and trusted) or the shadowy LPO and hired gun IMCN mercs. (Can anybody truly trust

a soldier who is not part of the community and just works for a paycheck?) Like the LPO and NG police force, most Monster Responders are citizens of Ishpeming.

Special Abilities of the Monster Responder O.C.C.

1. Exterminator: Monster Responders are used to the quick reflexes and animalistic movements of their prey. Their training includes defensive tactics for use against wild animals and monsters. It is their job to know the weak points and sensitive areas to take down or control monsters. **Combat Bonuses vs Monsters:** +2 on Perception Rolls, +1 on initiative, +2 to strike, parry and dodge against monsters and animals, including Xiticix and lesser demonic supernatural beings, vampires, Loup Garou, zombies, supernatural monsters and war steeds, and many creatures of magic. **Note:** Does not apply to intelligent D-Bees, aliens or mutants.

2. Use Animals to Hide Presence: Most types of predators, whether they are earthly or from other planets and dimensions, hunt using smell, sight and hearing. The creatures have learned to be aware of the sound of human voices and machines, the smell of people and vehicle exhaust, and can often adapt to urban settings. For Monster Responders, sneaking up on prey is important, and chasing monstrous creatures deeper into the wilderness can be just as bad as letting them escape. Monster Responders have learned to use riding animals to disguise their scent and help hide their presence. Nodosaurus, dinosaurs, Rhino-Buffalos, Fury Beetles and other large, trainable animals are used because of their size, toughness and the overwhelming nature of their body odor. Likewise, NG scientists have created a number of animal and monster scents, worn like perfume on their armor, to help Monster Responders mask their presence. Any monster or demon trying to detect the “human” Monster Responder when so masked or mounted on a horse or other riding creature is unlikely to detect him and is -2 on initiative and -2 to parry and dodge from the Responder’s initial attack.

Monster Responder O.C.C. Stats

Alignment: Any, but most are Scrupulous, Unprincipled and Anarchist.

Attribute Requirements: M.E., P.S. and P.E. of at least 9.

Racial Requirements: All *official* NG Monster Responders are human.

O.C.C. Bonuses: +2D6+8 S.D.C., +1D6 to Spd, +3 to save vs Horror Factor and +2 to roll with punch/impact.

O.C.C. Skills:

Camouflage (+10%)

Climbing (+10%)

Horsemanship: Exotic Animals (+15%)

Hunting

Land Navigation (+10%)

Lore: Demons & Monsters (+15%)

Lore: Faeries & Creatures of Magic (+10%)

Lore: Magic (+10%)

Lore: Vampires (+5%)

Mathematics: Basic (+15%)

Pilot: Hovercycle or Hover Craft (Ground) (+10%)

Prowl (+10%)

Radio: Basic (+10%)

Sniper

Swimming (+10%)

Track & Trap Animals (+10%)

Wilderness Survival (+15%)

W.P. Ancient: One of choice.

W.P. Energy Rifle

W.P. Heavy M.D. Weapons

Xenology (+10%)

Hand to Hand: Expert, but can be changed to Martial Arts (or Assassin if evil) at the cost of two O.C.C. Related Skills skills.

O.C.C. Related Skills: Select five other skills at level one. Add one additional skill at levels 4, 8 and 12. All new skills start at level one proficiency. These selections get the benefit of any bonuses that may be noted below.

Communications: Any (+5%).

Cowboy: Any (+5%).

Domestic: Any.

Electrical: Basic Electronics only.

Espionage: None.

Horsemanship: General, only.

Mechanical: Basic Mechanics only.

Medical: First Aid and Veterinary Science only (+10%).



Military: Any.
Physical: Any.
Pilot: Any.
Pilot Related: Any.
Rogue: Streetwise and Tailing only (+5%).
Science: Biology and Zoology only (+5%).
Technical: Any (+10% to any lore and animal related skills only).
W.P.: Any.
Wilderness: Any.

Secondary Skills: Three Secondary Skills at first level. Selections are made from the Secondary Skill list on page 300 of **Rifts® Ultimate Edition**. These are additional areas of knowledge that do not get any bonuses, aside from any possible bonus from having a high I.Q. attribute. All Secondary Skills start at the base skill level.

Standard Equipment: NG weapon for each W.P. plus 1D4+3 extra E-Clips for each (heavy weapons may include rail guns, mini-missile launcher, plasma cannon, etc.), Vibro-Knife, regular survival knife, suit of Northern Gun M.D.C. body armor of choice, gas mask and air filter, first aid kit, 1D4 fusion blocks, 1D6 hand grenades, 1D4 smoke grenades, 1D6 flares, binoculars, nightvision goggles, wilderness clothing, hiking boots, camp stove, 1D4 weeks of rations, clock/compass, portable tent and sleeping bag. May also have access to power armor and military vehicles for special missions against particularly powerful and nasty monsters.

Money: Starts with 2D6x1000 credits. Some Monster Responders work in specific communities or areas and are on call at all hours. Others perform contract work or are paid on a per-job basis.

Cybernetics: None to start. Many Monster Responders will receive a number of cybernetic implants over their career and get bionic or Bio-System replacements for lost limbs and organs in the line of duty.

NG Police Officer O.C.C.

The cities and communities of the Ishpeming Republic are home to all Northern Gun workers and citizens. Unlike the frontier, where border defense is the first priority and mercenary companies are close at hand, the industrial centers and population belt need a force capable of handling urban crime and city defense. In order to uphold law and order amongst a large civilian population and the many visitors from the outside world, the traditional Ishpeming Police Department has been retained to the present day.

A holdover from the days before the mercenary contract system was put in place, Ishpeming's law enforcement remains populated by actual residents of Ishpeming, not mercs. This means the Ishpeming Police Department (IPD) are residents who were born, raised and live in the Republic. The Ishpeming Police Department is a serious law enforcement organization; limiting their efforts primarily to peacekeeping, protection of NG citizens and bringing to justice murderers, violent criminals, and anyone who threatens the profits and holdings of Northern Gun. Due to the corporate hierarchy's willingness to overlook many minor crimes, the IPD actually has a very high proportion of detectives and SWAT team-style tactical response officers, as well as a large number of highway patrol on Police rocket bikes and beat cops to keep the streets safe,

especially in the Downtown area. All are dedicated professionals accustomed to dealing with perpetrators who have been augmented with cybernetics, M.O.M., Juicer technology or magic.

Another job is to monitor the local roads and the IM Highway that leads from Ishpeming to Manistique. Within its major cities, the Republic of Ishpeming has a great deal of foot traffic and vehicular traffic that needs to be managed.

Unlike many places where the police are regarded as oppressors or corrupt brutes, at Northern Gun they are regarded as respected defenders of the people who protect the peaceful and law-abiding Ishpeming citizens from the uncivilized and unruly cavalcade of visitors who come from the outside world. Mercs, bandits, pirates, adventurers and wilderness people are often rude, crude, aggressive and scary to the educated gentry of Ishpeming/NG communities.

The Ishpeming Police Department (IPD) works extensively with the Loss Prevention Office and various mercenary groups, and can call in serious firepower if a situation gets out of their hands. While they are small and underfunded compared to the vast and systematic ISS within the Coalition States, the IPD law officers are tough and resourceful.

While the IPD's jurisdiction technically extends within all of the Republic of Ishpeming, they normally stick to *Ishpeming/Northern Gun, Marquette* and the surrounding cities. *Escanaba* has its own law enforcement in the form of the mercenary company known as *the Patrol*, though the IPD does maintain a small office in Escanaba for exchanging criminals and swapping case information with the Patrol.

IPD officers work four 10-12 hour days a week, have three days off, work eight days in a row, have six days off and repeat. This gives them time to relax, reduce stress and keep their edge. However, since the police are allowed to engage in freelance work on their time off, many do that work on the side or even go on short adventures outside of town. This is easy since many have connections with members of the LPO, and are likely to know many businesspeople, merchants, traveling merchants, private detectives, mercenaries, freebooters, and adventurers. All of whom may have short jobs and need for a man with police connections, knowledge of the Ishpeming streets and police skills. In fact, within the city-state, their knowledge of the streets and of criminal operations and the crooks involved may give the police an advantage in recovering stolen goods, items being fenced, etc. For that matter, they know many unsavory types, from crooks to pirates, to snitches and City Rats.

A player character may also be a retired NG Police Officer who found more rewarding work or better paying work in the private sector. Likely jobs are private detective, security specialist, bodyguard, installing and finding bugs, finding and stopping security leaks, spying, troubleshooting on behalf of a client, and similar jobs that require police work, police connections or a little muscle.

Special Abilities of the Ishpeming Police Officer O.C.C.

1. Area of Specialty: There are Police Officer and several sub-departments who focus on all the various aspects of law enforcement. All have the same basic training in small arms and police procedure, but newly appointed Police Officers pick their eventual specialization after just six months and start receiving further advanced training shortly after that.



Crisis Response Officer: The IPD equivalent of a SWAT team, Crisis Response Units are called in to deal with Juicers, Crazies, magic users, D-Bees and perps equipped with military armor or vehicles. They typically employ military-grade weapons, often using Guardsman, Defender or Juicer Killer power armor to give them an edge. The department also has a number of Blue Hawk and Ironwing flying power armor suits for apprehending criminals who take to the skies, as well as a few serious combat robots with police markings and sirens.

Crisis Response Officer Specialty Skills:

- Demolitions Disposal (+14%)
- Detect Ambush (+5%)
- Lore: D-Bees (+10%)
- Lore: Juicers (+15%)
- Pilot: Robots & Power Armor (+15%)
- Robot Combat: Basic
- W.P. Heavy M.D. Weapons

Bonuses: +2D6 S.D.C., +1 attack when using a gun the entire melee round.

Highway Patrol: Spending their days zipping up and down the IM Highway and throughout the streets of Ishpeming's urban centers, Transportation Enforcement Specialists, commonly known as "Rocket Cops," play an important role monitoring traffic flow, responding to accidents, and keeping the streets safe as well as fast response to, and high-speed pursuits, of fleeing criminals. They weed out known offenders and unsafe vehicles, assist lost or stranded motorists, and engage in white-knuckled, high-speed chases with the most daring or desperate outlaws.

Highway Patrol Specialty Skills:

- Basic Mechanics (+10%)
- Combat Driving
- Land Navigation (+10%)
- Roadwise: Ishpeming (+15%)
- Tailing (+10%)

Highway Patrol Bonuses: +10% bonus to Pilot: Hovercycles, Skycycles & Rocket Bikes, +1 on initiative and +1 to dodge when driving a rocket bike or hovercycle, +3% on all stunt driving and evasive maneuvers; +2 on Perception Rolls to determine whether a crime is in progress, somebody looks or is behaving suspicious-

ly, and to recognize known criminals, fugitives and criminal gang members.

Investigator: When a body is found or evidence of a crime discovered that needs followup, the IPD's Investigators go to work. The equivalent of detectives or Coalition Specters, IPD Investigators are real sleuths who rely on scientific evidence, gut hunches, and, for those who have them, use psionics to find the truth and bring perpetrators to justice. Investigators might technically be under the authority of the Ishpeming civil government, but they are still Northern Gun employees and protecting the company and its profits comes first, and is generally more important than preserving the rights of the accused or even the citizenry.

Investigator Specialty Skills:

- Crime Scene Investigation (+15%)
- Find Contraband (+10%)
- Interrogation (+15%)
- Research (+10%)
- Surveillance/Tailing (+15%)
- T.V./Video (+15%)

Psionics Among Investigators: Roll percentile dice or pick one.

- 01-20% Minor Psychic with two Sensitive abilities.
- 21-40% Major Psychic with 8 Sensitive abilities.
- 41-60% Major Psychic with 3 Sensitive and 3 Physical abilities.
- 61-80% Major Psychic with 8 Healing abilities.
- 81-90% No psionics, but +1 to M.E. attribute and +2 on Perception Rolls to find clues, recognize suspects, notice inconsistencies and to recognize suspicious people, occurrences and coincidence.
- 91-00% The Investigator is a Master Psychic O.C.C. of choice. The most appropriate being Mind Melter, Rogue/Feral Dog Boy, Psi-Stalker, Psi-Ghost and Psi-Tech. **Note:** In the event a player does not want to be a Psychic O.C.C., select one of the previous. If the player doesn't want psionic powers at all, select 81-90%.

Undercover Agent: With so many groups of pirates, raiders, con artists and thieves amongst its clientele, it behooves Northern Gun to be aware of their activities. A reliable customer and an opportunistic bandit might be one and the same, and the only way

to know for sure is to be aware of what jobs are planned ahead of time. In the Coalition, the citizens are monitored by cameras, Dog Boys and identification papers, things rarely seen in Ishpeming. What Northern Gun does have, however, is an almost unlimited supply of down-on-their-luck scouts, spies, criminals, con men and mercenaries, many of whom are perfectly willing to infiltrate and report on their competitors. The most skilled are recruited by the Ishpeming Police Department, trained and sworn in as Police Officers, and then sent back out into the wild. The intelligence they provide is invaluable for keeping Northern Gun one step ahead of the countless thieves and Black Marketeers who are constantly trying to rip them off.

Undercover Agent Specialty Skills:

Disguise or Prowl (+15%)
I.D. Undercover Agent (+6%)
Impersonation (+20%)
Intelligence (+15%)
Performance (+20%)
Undercover Ops (+15%)
Surveillance/Tailing (+10%)

2. Call for Backup: IPD officers rarely work alone, and are almost always in radio contact with a partner or supervisor. Moreover, they may call for backup anywhere in the Republic of Ishpeming and can expect 1D4+3 additional police (or they may request mercs if they are more appropriate to the situation) to their location within 1D4 minutes in urban settings, 3D4 minutes in rural areas. Triple the number of backup personnel in the case of an emergency, high level threat or officer down. The IPD can also call upon the LPO when NG corporate interests are at stake, and they cooperate with all Northern Gun authorities and protectors.

Ishpeming Police O.C.C. Stats

Alignment: Any, though most are Principled (30%), Scrupulous (40%) or Unprincipled (10%). Dirty cops amongst the IPD are a rarity, but when they go bad they are likely to be Anarchist or any evil alignment.

Attribute Requirements: I.Q., P.S., and P.P. of 10 or higher.

Racial Requirements: Only humans are allowed to officially serve within the Ishpeming Police Department. D-Bees and magic users will be relegated to the status of 'confidential informants' or 'special contractors.' Some Investigators are known to employ psychics or even magic users to help them solve a case.

O.C.C. Bonuses: +2 to P.S., +1D6 to Spd, +2D6 S.D.C., +2 to pull punch.

O.C.C. Skills:

First Aid (+5%)
General Athletics
Language: Native Language, American.
Language: Other: One of choice (+10%).
Literacy: American (+20%)
Law, General (+20%)
Pilot: Pilot: Hovercycles, Skycycles and Rocket Bikes (+5%)
Pilot: Hover Craft (+10%)
Radio: Basic (+10%)
Streetwise (+10%)
W.P. Blunt
W.P. Energy Pistol
W.P. Energy Rifle

Hand to Hand: Expert, but it can be changed to Martial Arts for the cost of one O.C.C. Related Skill.

O.C.C. Related Skills: In addition to Area of Specialty Skills, select four two additional skills at levels 3, 6, 9 and 12. All new skills start at level one proficiency. These selections get the benefit of any bonuses that may be noted below.

Communications: Any (+10%).

Cowboy: None.

Domestic: None.

Electrical: Basic only.

Espionage: Any.

Horsemanship: Horsemanship: General and Horsemanship:

Exotic Animals only.

Mechanical: Basic only.

Medical: Paramedic only.

Military: Any.

Physical: Any.

Pilot: Any.

Pilot Related: Any.

Rogue: Any.

Science: Any.

Technical: Any.

W.P.: Any.

Wilderness: Any.

Secondary Skills: Five Secondary Skills at first level. Selections are made from the Secondary Skill list on page 300 of **Rifts® Ultimate Edition**. These are additional areas of knowledge that do not get any bonuses, aside from any possible bonus from having a high I.Q. attribute. All Secondary Skills start at the base skill level.

Standard Equipment for ALL IPD: Street uniform, dress uniform, *NG 122-EXO Light Police Power Armor* (statted out, below) or any light or medium Northern Gun M.D.C. body armor painted in police colors and logo are also available (most commonly requested by Investigators and Undercover Agents), police badge/I.D., citation book, headset radio, pocket computer, laser distancer, 2 sets of M.D.C. handcuffs, 1D4x10 zip ties (2D4 S.D.C.), extendable baton (2D4 S.D.C. damage), S.D.C. pistol of choice and 4 extra clips of ammunition, Northern Gun energy rifle and energy pistol of choice with 4 extra E-Clips for each.

Crisis Response Officer: Mantis, Defender, Juicer Killer or Samson power armor. CROs "on foot" typically use *NG 122-EXO Light Police Power Armor* (statted out, below) or other NG medium or heavy body armor, sniper rifles and heavier weapons like plasma ejectors and particle beam rifles. The GL10 grenade launcher is extremely popular due to its versatility as is the use of tear gas and stun grenades. Extra E-Clips, hand grenades, patrol hover cars, Crisis Response Vehicles and even tanks and robots are all available depending on the assignment.

Highway Patrol: Standard issue armor is the *NG 122-EXO Light Police Power Armor* (statted out, below), standard vehicle is the *Police Interceptor Rocket Bike* (statted out below), but a few officers prefer the NG Turbo, StreeRunner, or Joust hovercycle models and can put in a special request. Northern Gun has access to so many inexpensive hovercycles that officers are allowed to use whichever model they prefer. The Red Hawk power armor, Sky King aircraft and jet packs are also used by Hovercycle IPD. All-terrain vehicles may be used when tracking suspects through wilderness areas.

Investigator: Investigators are equipped with field computers that can access the entire Northern Gun customer and criminal database. They are issued crime scene investigation kits used for fingerprinting, gathering DNA evidence, etc. Investigators drive Urban Patrol Hovercars while on duty and can request uniforms from Northern Gun's Loss Prevention Office, maintenance or sales departments in order to go unnoticed amongst employees. They often work in street clothes to pass themselves off as customers or bystanders.

Undercover Agent: Small side arm like the NG Holdout ion pistol, along with a Vibro-Blade of choice. Whatever equipment, surveillance equipment, clothing, disguises, vehicles or cash is necessary for an agent's assignments will be issued on an as needed basis. A hovercycle, motorcycle, hovercraft or jet pack is provided for field work.

Money: Average salary is 6,000 credits per month. Starts off with 2D4x1000 credits. Inspectors and officers ranked sergeant or above make a monthly salary of 8,000 credits.

Cybernetics: None to start. Some police officers have eye-cameras, radios, clock-calendars, augmented hearing, molecular analyzers, vital-signs monitors, tracking beacons and other cybernetics installed internally to help them on the job.

Police NG Interceptor Rocket Bike

Northern Gun has provided the IPD with a prototype rocket cycle "inspired" by CS rocket bikes. Built for speed, they are designed for patrolling the IM Highway, rural roads and city streets, fast-response and chasing down criminals in slower vehicles. And at 300 mph (480 km) and an altitude of 1,600 feet (488 m), that's most land vehicles and power armor. It is also equipped with an S.D.C. and M.D. laser for warning shots and strafing runs, or to take down a perp who cannot be persuaded to stop and surrender with warnings, and a battery of mini-missiles for armored opponents and monsters. **Note:** This rocket cycle is exclusive to the IPD and is not available on the open market; not even to the police of other kingdoms.

Model Type: NG-RB-122

Class: Rocket Cycle, Police Interceptor.

Crew: One pilot.

M.D.C. by Location:

- * Heavy M.D. Laser (1; nose) – 20
- * Light S.D.C. Laser (1; nose) – 10
- * Mini-Missile/Mini-Torpedo Tubes (2; side) – 25 each
- Reinforced Windshield (1; front) – 15
- * Nose Police Lights & Headlights (2; nose) – 4 each
- ** Directional Jets (8; concealed) – 10 each
- Rocket Jet (1; rear) – 50
- * Tail Fin (1; rear) – 45
- *** Main Body – 122

* A single asterisk indicates a small and/or difficult target to strike, requiring the attacker to make a "Called Shot," and even then the attacker is -4 to strike.

** Destroying four or more of the directional jets inflicts a piloting skill penalty of -15%. Destroying 6-8 inflicts a penalty of 25%. Destroying the main rocket jet only reduces speed to hover and 3 mph (4.8 km).

*** Depleting the M.D.C. of the main body shuts the vehicle down completely and renders it useless.

Speed:

Land: 200 mph (320 km) maximum without going airborne and ascending to an altitude of at least 50 feet (15.2 m), automatically. Flight capable, see flying below.

Water: The Police Interceptor can also fly over the surface of water up to full speed, but cannot ride on the surface or underwater; sinks like a rock.

Flying: 300 mph (480 km) maximum, but cruising speed is considered to range between 45 and 90 mph (72 to 144 km). VTOL capable and it can hover stationary. Maximum altitude is 1,600 feet (488 m) over land or water.

Flying Range: 8 hours of continuous flight before the engine gets too hot and needs to be shut down to cool. Pushing it is likely to shut the engine down – 20% chance per every additional 10 minutes of flight beyond 8 hours, with cumulative penalties – and causes the rocket bike to crash.

Statistical Data:

Height: 5 feet, 9 inches (1.8 m).

Width: 5 feet (1.5 m).

Length: 12 feet (3.6 m).

Weight: 1,300 lbs (585 kg).

Cargo: A small compartment on the side between the seat and tail that is large enough to hold a first-aid kit, a canteen, three spare E-Clips for an energy pistol, two flares, a walkie-talkie and lunch.

Power System: Nuclear; average energy life is 12 years. Solid Oxide and electric battery versions are also available.

Cost: Nuclear 1.2 million credits, Solid Oxide 850,000 credits, electric battery 650,000 credits.

Weapon Systems:

1. Dual Nose Laser: A pair of forward fixed lasers are mounted on the nose of the Interceptor. The large barrel does M.D., the small one under it does S.D.C. damage. The driver controls which laser fires with the press of a switch. The S.D.C. laser can also be switched to inflict no damage, to be used as a targeting and distance measuring laser system.

Primary Purpose: Anti-Personnel.

Secondary Purpose: Assault and Defense.

Range: Heavy M.D. Laser: 1,500 feet (457.2 m). Light S.D.C. Laser: 1,500 feet (457.2 m).

Mega-Damage: 3D6 M.D. heavy laser or 4D6 S.D.C./Hit Point damage.

Rate of Fire: Each blast counts as one melee attack.

Payload: Effectively unlimited.

2. Side Mounted Mini-Missile Launchers (2): On each side of the Police Interceptor is a mini-missile turret capable of a 360 degree up and down arc of fire.

Primary Purpose: Anti-Ship.

Secondary Purpose: Anti-Sea Monster.

Range: About one mile (1.6 km).

Mega-Damage: Varies by mini-missile or mini-torpedo type. Mini-torpedos are common only for dock patrols and special ops against water/boat-based criminals. **Note:** Plasma and Fragmentation missiles are NEVER used by the Police, because they create too much collateral damage and loss of life, especially in an urban setting.

The Standard IPD Mix of Mini-Missiles:

2 Smoke Mini-Missiles: 40 foot (12.2 m) radius smoke cloud to obscure vision and confuse escaping criminals or rioters; one mile (1.6 m) range.

4 Riot Pacification Mini-Missiles/Tear Gas: 30 foot (9.1 m) radius cloud of tear gas. Penalties to all without protective eye-coverings and gas mask: -3 on initiative, -5 to strike, parry and dodge for 1D4+4 melee rounds (half duration in a strong wind). Those in environmental body armor or air-tight vehicles are safe and not affected; half mile (0.8 m) range.

6 High Explosive: 5D6 M.D. to a 5 foot (1.5 m) blast radius; anti-vehicle/light armor; one mile (1.6 m) range.

4 Armor Piercing: 1D4x10 M.D. to a 3 foot (0.9 m) blast radius; anti-cyborg/robot/heavy armor; one mile (1.6 m) range.

Rate of Fire: One at a time or in volleys of two or four.

Payload: 16 mini-missiles/mini-torpedoes; 4 per launcher. Mini-missiles can be substituted with torpedoes for special dock and lakeside operations.

3. Special Systems of Note: A) Flashing red and blue police lights and siren in the front of the nose, plus flashing running lights around the entire nose of the rocket bike and the missile launchers.

B) Loudspeaker, tied to helmet.

C) Built-in short- and long-range radio tied to helmet.

NG 122-EXO

Light Police Power Armor

NG Police wear a suit of armor that is exclusive to the IPD. Whether it should be considered a heavy body armor with exoskeleton for additional augmentation or as a light power armor suit is a matter of debate. Inspired by the *Triax T-11 Enhanced Body Armor* (reverse-engineered), this bulky armor provides superior protection, especially to the main body, and the exoskeleton provides augmented P.S. and Spd.

● **M.D.C. by Location:**

Helmet – 50

Arms (2) – 25 each

Legs (2) – 50 each

Main Body – 120

● Weight: 50 pounds (22.5 km).

● Fair mobility, -12% mobility penalty to Acrobatics, Gymnastics, Prowl and Swimming, but no penalty to Climbing or Running.

● The exoskeleton augments the wearer and adds the following bonuses to the police officer wearing it: +6 to P.S., +8 to Spd, +6 feet (1.8 m) to leaps (height and distance), and reduce the rate of fatigue by 50%.

● IPD colors, a matte gray armor with blue, red, and black highlights, and the NG logo; same color scheme for their Interceptor Rocket Bikes.

● Exclusive to the Ishpeming/NG Police. Not available on the retail market, but if it was, the armor is likely to sell for 100,000-150,000 credits.

NG Robot Control O.C.C.

Robot Control agents are part Operator and part Cowboy who wrangles robots. When a robot or drone runs amok, or a Robot Pilot inside a robot runs amok, NG Robot Control brings it down fast, and with an eye to minimizing collateral damage. Drones gone haywire, sabotaged giant combat robots out of control, drunk and disorderly mercs and visitors in power armor or robot vehicles, are all dealt with in different, but expedient ways. The Robot Control agent has a number of secrets and tactics for incapacitating or neutralizing drones and robots, but may try to talk a robot pilot down or work to distract him while another Robot Control agent sneaks around to incapacitate the vehicle (disconnect its power supply, knock out sensors and targeting system, etc.) or incapacitate the pilot. Other times, the Robot Control agent may do things to distract, wrangle or engage a runaway robot to keep it from doing more damage, or lure it away from people and property until more forces can arrive to destroy it or handle the situation.

Special Abilities of the Robot Control O.C.C.

1. Disable Robot Operating Systems: The Robot Control receives special training to quickly takedown robots that have gone haywire. The ability is exclusive to this O.C.C. and functions as an *additional +20% bonus* to all Mechanical and related skills (see below), but **ONLY** when used to temporarily disable/disconnect/knock-out various robot functions or mechanical systems in order to undermine the operation of out of control robots. The bonus applies only when the character is trying to *disable* a robot one system at a time, deactivate weapon systems, optics, etc. This bonus is in addition to any other skill bonuses.

This includes skills such as *Computer Repair* (or in this case, to disengage/disconnect or interfere with computer operations), *Jury-Rig* (to get something not to work), *Laser Communication* (to stop or interrupt it), *Locksmith* (to gain entry into a robot vehicle or to make it so others cannot enter, disengage key pads, etc.), *Optic Systems* (to disconnect or disable it/blind the robot or its pilot), *Radio: Basic* (to knock out the incoming and outgoing radio transmissions), *Sensory Equipment* (to scramble and confuse data, disconnect or shut sensors down), *Surveillance* (to scramble, disconnect or shut it down), *T.V./Video* (to scramble, disconnect or shut it down), and *Weapon Systems* (to disconnect, disable or shut a specific weapon system down/make unavailable to the 'Bot), but **ONLY AS THEY APPLY TO ROBOTS, DRONES and POWER ARMOR**. The bonus also applies when repairing or reconnecting what the character had disabled to the way it was or with the proper fixes.

2. Psionics Amongst Robot Control Agents (Special): Roll Percentile dice or pick one. In all cases where the Robot Control agent is a "Master" Psychic, he is not any of the usual Master Psychic O.C.C.s, but one of the specialized ones below. As a result, the character is not as powerful as most other Master Psychics and is specialized in combating robots and machines. Base I.S.P. is M.E. attribute number plus 2D6x10, +10 I.S.P. per each additional level of experience. Skills are as per this Robot Control O.C.C.

01-20% Robot Battler, Master Psychic: Has the Super-Psionic powers *Telematics (10)*, *Telematic Mental Paralysis (20)* and *Electro-Kinesis (varies)* at level one.



Psi-Shield (30), Object Read (6), Psi-Ghost (12), Summon Inner Strength (4) and Resist Fatigue (4) at level two.

Hydrokinesis (varies), Intuitive Combat (10), and Mind Block (4) at level three. Starting at level four, the Robot Battler can select a total of two additional psionic powers per subsequent levels of experience. The two powers can only be selected from the categories of Physical and Sensitive.

21-40% Robot Whisperer, Master Psychic: Has the Super-Psionic powers *Telemechanics (10), Telemechanic Mental Operation (12), and Telemechanic Mental Paralysis (20)* at level one.

Telemechanic Possession (50) plus Object Read (6), Psi-Ghost (12), Sense Time (2) and Resist Fatigue (4) at level two.

Group Trance (15), Remote Viewing (10), Meditation (0), and Mind Block (4) at level three.

Starting at level four, the Robot Whisperer can select a total of two additional psionic powers per subsequent level of experience. The two powers can only be selected from the categories of Sensitive and Healing.

41-60% Robot Slammer, Master Psychic: Has the Super-Psionic powers of *Telemechanics (10), Telekinesis Super (10+)* and *Telekinetic Acceleration Attack (10-20)* at level one.

Bio-Manipulation (10) for use against the robot operator when applicable, plus *Telekinesis (varies), Telekinetic Leap (8), Telekinetic Lift (6)* and *Telekinetic Punch* at level two.

Telekinetic Force Field (30) plus Telekinetic Push (4), Resist Fatigue (4), and Ectoplasm (6-12) at level three.

Starting at level four, the Robot Slammer can select a total of two additional psionic powers per subsequent level of experience. The two powers can only be selected from the categories of Physical and Sensitive.

61-70% Robot Responder, Major Psychic: Has the Physical abilities of *Telekinesis (varies), Telekinetic Leap (8), Telekinetic Lift (6)* and *Telekinetic Push (4)*, plus four Physical abilities of choice.

71-80% Minor Psychic: Two psi-abilities: *Machine Ghost (12)* and *Object Read (6)*, and +1 to M.E. and +1D6 to Spd attributes.

81-00% Gut Instincts: No psionics, but +1 to P.P., +1D6+1 to Spd attribute, and +2 on Perception Rolls involving ways to incapacitate, stop and destroy robot sensors, weapon systems, power supply, and the 'Bot itself, as well as finding clues and

signs of deliberate sabotage or faulty parts. The Perception bonus also equates to an additional +2% skill bonus to all Electrical, Mechanical and Demolitions skills.

Note: In the event a player does not want to be a Master Psychic, select 71-80% or 81-00%.

NG Robot Control O.C.C.

Alignment: Any, but the vast majority are Principled, Scrupulous or Unprincipled.

Attribute Requirements: I.Q., M.E. and P.P. of 9 or higher. A high P.E. and Spd can come in handy, but is not required.

Racial Requirements: Any. Most *official* NG Robot Control agents are human, though 20% are D-Bees of varying types.

O.C.C. Bonuses: +1 to M.E., +1 on Perception Rolls involving robots, drones, power armor and potential crisis situations involving them.

O.C.C. Skills:

Basic Electronics (+15%)

Computer Operation (+10%)

Computer Repair (+10%)

Demolitions (+20%)

Demolitions Disposal (+20%)

Jury-Rig (+15%)

Language: Native Language, American (+10%)

Language: Other: One of choice (+10%).

Literacy: American (+15%)

Locksmith (+10%)

Mechanical Engineer (+10%)

Optic Systems (+5%)

Pilot: One non-military vehicle of choice (+10%).

Pilot: Robots & Power Armor (+10%)

Radio: Basic (+10%)

Robot Mechanics (+20%)

W.P. Energy Rifle.

W.P.: One of choice (any).

Hand to Hand: Basic, but it can be changed to Expert at the cost of two O.C.C. Related Skills or Martial Arts (or Assassin if evil) for the cost of three skill selections.

O.C.C. Related Skills: Select four other skills at level one. Add one additional skill at levels 3, 6, 9 and 12. All new skills start

at level one proficiency. These selections get the benefit of any bonuses that may be noted below.

Communications: Any (+5%).

Cowboy: None.

Domestic: Any.

Electrical: Any.

Espionage: None.

Horsemanship: None.

Mechanical: Any (+10%).

Medical: First Aid and Psychology only (+10%).

Military: Military Etiquette and Recognize Weapon Quality only (+5%).

Physical: Any.

Pilot: Any, including Robot and Power Armor skills.

Pilot Related: Any.

Rogue: Computer Hacking (+10%) only.

Science: Any (+5%).

Technical: Any (+5%).

W.P.: Any.

Wilderness: None.

Secondary Skills: Four Secondary Skills at first level. Selections are made from the Secondary Skill list on page 300 of **Rifts® Ultimate Edition**. These are additional areas of knowledge that do not get any bonuses, aside from any possible bonus from having a high I.Q. attribute. All Secondary Skills start at the base skill level.

Standard Equipment: Northern Gun weapon of choice for each W.P., 1D6 extra E-Clips for each, Laser Torch, portable tool kit, one NG Power Pack (any type), NG-S2 survival kit, I.D. and credentials, light or medium NG body armor of choice, walkie-talkie, nightvision goggles, 2 auditory listening bugs, 1 micro-video camera, field computer, compass, canteen and hiking boots, plus personal items.

Standard issue includes one suit of Samson or other light or medium NG power armor of choice and a hovercycle (any NG brand) or robot horse (any NG or Bandito Arms knock-off brand). Somewhere along the line, many Robot Control agents decided it was cool to ride a robot horse without any cosmetic covering or hide; it looks like a robot horse. NG Robot Control agents also enjoy limited access to a wide range of Northern Gun products, including explosives and heavy weapons, made available upon special assignment. Seldom includes heavy combat robots or prototypes.

Money: Pay is 5,000 credits per month in NGMI credits, plus bonuses for outstanding field work, and NG usually pays for any medical bills due to injuries on the job. Characters start out with one month's pay.

Cybernetics: Unless a Robot Control Agents is a psychic who fears bionics and implants will impair his psionic abilities, many agents have a number of cybernetic or minor bionic implants installed. They may also receive bionic or Bio-System replacement parts, paid for by the company, for limbs and organs lost or damaged beyond repair in the line of duty. Otherwise, additional cybernetics and bionics *may* be offered in the form of bonuses and special rewards. ALL bionic augmentation must be authorized by the company, though as many as eight legal, cybernetic enhancements are allowed. Only 5% of Robot Control agents are partial cyborgs, and there are no Combat Cyborgs on the force. Augmented warriors such as *Headhunters*, *Combat Cyborgs*, *Juicers*, *Crazies*, *Psi-Tech*,

and so on, are hired for special operations as independent, third-party contractors (i.e. mercenaries).



NG Sales Rep O.C.C.

The rank-and-file contract employees of Northern Gun include specialists like Operators, scientists, security people and even official psychics. Most of the employees who customers interact with, however, are *Sales Representatives*. Unlike the customer service jobs that we know today, Northern Gun staff are expected to accompany shipments on perilous journeys and to sell the company's products to the most dangerous and unpredictable clients. Sales Reps are on duty at every official Northern Gun outlet and are called upon for special orders and deliveries to remote locations.

Remember, though Northern Gun makes a lot of everything, it is most famous as an arms dealer. To sell weapons and war machines, you must know how they function and how to use them. Thus, as both a Sales Rep and someone expected to protect stock from theft and hostile forces, most NG sales people know their way around the business end of combat vehicles, robots and power armor, and are good with a gun. Sales Reps are experienced with most Northern Gun equipment, sales procedures and deliveries. Most NG arms dealers have spent more than a few years working their way up from lower sales positions and jobs within the maintenance or security divisions to get where they are today in sales. And they intend to hold on to their position. Sales Reps are typically armed, well informed and have the ability to

call for backup from the IMCN or the Loss Prevention Office as necessary.

NG City Sales Reps are often technical specialists and people who demonstrate a natural affinity for convincing customers to commit to purchases. Wilderness or “field” Sales Reps, as well as those stationed in Escanaba or Menominee, are salesmen, to be sure, but also have linguistic skills and familiarity with certain groups of mercenaries and tribal people, making them much more familiar with frequent and local buyers. All NG Sales Reps are trained to be discreet and able to sell to anyone, including secret shipments to non-humans, practitioners of magic, pirates, criminals and Black Marketeers.

Special Abilities of the NG Sales Rep O.C.C.

1. Salesmanship: Northern Gun Sales Representatives are skilled in basic sales techniques and negotiation strategies. They know which products can be marked down in price, which are in short supply, which can command top dollar (or more), and how to convince customers that they “need” upgrades and extras. This skill rather works like the Seduction skill, only those under its effects are more likely to trust the salesman and pay 100% of list price for NG products. **Base Skill:** 30% +3% per level of experience for most good salespeople, +10% for Black Market Merchants, +22% for NG Sales Reps, Fingertooth Carpetbaggers, and Splugorth Merchants, and +30% for Naruni Sales Agents.

2. Northern Gun Product Familiarity: Unlike Loss Prevention Officers, Sales Reps’ familiarity with NG products is more technical and less related to their actual use. That means they know how the items work, have at least a passing familiarity, and know the technical specifications. The percentage number indicates the level of familiarity and any roll under it means the Sales Rep can clean, reload, and fix any jams, minor defects or common malfunctions of any Northern Gun weapon, vehicle or device. **Base Skill:** 57% +3% per level of experience.

3. Northern Gun Distribution Network: While they don’t have the mystique and air of authority that surrounds Loss Prevention Officers, Sales Reps are well-versed in Northern Gun’s supply chain and can usually find a way to get themselves and/or product anywhere NG has an outlet store, even if they have to forge paperwork or ride along “off the books.” This includes knowing who are the best Bush Pilots, how to contact them, their pay rates and how to entice them into taking the job for the lowest fee. NG Reps also have contacts and connections with numerous mercenary companies, independent operators (e.g., the player group) and the Black Market. They can also call upon the police and the LPO regarding matters of theft, piracy, sabotage, etc.

Northern Gun Sales Representative O.C.C. Stats

Alignment: Any, but most are Scrupulous, Unprincipled and Anarchist.

Attribute Requirements: The higher the M.E. and M.A. the better, but both must be at least 10.

Racial Requirements: All *official* Northern Gun Sales Reps in Ishpeming are human. Out in the field, 15% are D-Bees.

O.C.C. Bonuses: +10% to charm/impress.

O.C.C. Skills:

Appraise Goods (+10%)

Barter (+15%)

Basic Electronics (+5%) or Basic Mechanics (+5%)

Computer Operation (+15%)

Field Armorer & Munitions Expert (+10%)

Language: One of choice (+10%).

Literacy: American (+20%)

Mathematics: Basic (+30%)

Pilot: Hovercycles (+10%) or Hover Craft (+10%)

Pilot: Truck (+15%) or Tanks & APCs (+5%)

Pilot: Robots & Power Armor (+2%)

Radio: Basic (+5%)

Recognize Weapon Quality (+15%)

Wilderness Survival

W.P. Energy Pistol

W.P. Energy Rifle

W.P. Heavy M.D. Weapons

Hand to Hand: Basic, but it can be changed to Expert at the cost of two O.C.C. Related Skills or Martial Arts (or Assassin if evil) for the cost of three skill selections.

O.C.C. Related Skills: Select five other skills at level one. Add one additional skill at levels 3, 6, 9 and 12. All new skills start at level one proficiency. These selections get the benefit of any bonuses that may be noted below.

Communications: Any.

Cowboy: None.

Domestic: Any.

Electrical: Any.

Espionage: Any.

Horsemanship: Any.

Mechanical: Any.

Medical: First Aid only.

Military: Any.

Physical: Any.

Pilot: Any.

Pilot Related: Any.

Rogue: Any.

Science: Any.

Technical: Cybernetics: Basic or General Repair & Maintenance only.

W.P.: Any.

Wilderness: Any.

Secondary Skills: Four Secondary Skills at first level. Selections are made from the Secondary Skill list on page 300 of **Rifts® Ultimate Edition**. These are additional areas of knowledge that do not get any bonuses, aside from any possible bonus from having a high I.Q. attribute. All Secondary Skills start at the base skill level.

Standard Equipment: NG light M.D.C. body armor, NG energy pistol of choice, 4 spare E-Clips, pocket computer, personal radio (10 mile/16 km range), Northern Gun sales uniform, traveling clothes, hiking boots, backpack, knapsack, binoculars, waterproof lighter, 1D4x10 copies of the Northern Gun catalog.

Wilderness Sales Reps will most likely have a personal vehicle such as a motorcycle, hovertruck or hovercycle. Some will use riding animals that are better suited to the terrain.

Money: Pay is 4,000 credits per month in NGMI credits. Characters start out with one month’s pay.

Cybernetics: None to start. Some Sales Reps will have computers or communication devices installed to help them with their jobs. Many acquire minor helpful and cosmetic cybernetics over time.

Freighter Traffic on the Great Lakes

Even with pirates and sea monsters to worry about, crossing the open water of the Great Lakes is a much faster and safer travel method than trudging through the wilderness. The lakes and their adjoining waterways see some of the busiest traffic in all of North America, and Northern Gun is the *port of call* for many of them. **Escanaba**, as Northern Gun's primary port, is home to almost as many ships as the entire Coalition States, at least on paper. It is the capital for merchant shipping throughout the continent.

Pirates and sea monsters are the biggest threats to freighters on the lakes. The depth and size of the Great Lakes compounds this problem, enabling large sea serpents and submarines to prowl, unseen, in its dark waters. These threats necessitate armed – heavily armed – merchant shipping that can protect itself from all dangers, monstrous, inhuman and enemy naval forces alike.

Random Freighter Generation Tables

The following tables can be used by Game Masters to randomly determine the type of vessel and cargo a vessel is hauling, and our heroes protecting, perhaps, or the type of vessel pirates (the player characters, perhaps) are trying to capture and raid.

Step One: Ship Type

There are several different basic types of ships encountered on the Great Lakes. The type of vessel will determine its cargo, crew and size, as well as how attractive of a target it is to pirates.

01-33% General Cargo Vessels are the most common ship on the Great Lakes. They carry crates, pallets, barrels, large industrial and agricultural machinery, parts, ore, lumber, clothing or textiles, vehicles, military equipment and sales goods. Some cargo vessels are surprisingly small, others are massive container ships designed to offload their haul in boxcars directly onto train tracks or crates loaded into boxcars, semi-trucks or smaller boats. These are the vessels pirates look for, especially those that seem to be carrying new *Northern Gun* (Ishpeming) or *Wellington* (Manistique) products to market. Of course, pirates will target any type of vessel for valuables, including CS, Free Quebec, and sometimes, even each other.

34-45% Tankers carry oil, gasoline, diesel, natural gas, propane, other fuels and other liquid or gaseous products. While they are desirable targets for piracy (in that so much fuel is worth millions of credits), there is a downside to attacking a fully loaded tanker. While the fuel is carried in large, cellular containment tanks, it does not take much damage (30% of main body M.D.C. lost) for cracks to begin to develop and for bulkheads to come apart. After this point the insides of the tanker will begin to fill with the liquid and the crew, if wise, will bail out. One misplaced shot to a gas-soaked tanker ship can turn it into a giant fireball, destroying the vessel and any hopes the pirates had of turning a profit. Of course, sometimes that is the pirates' ultimate goal, and "fire-ships" designed to be used as floating bombs have been a part of naval strategy since the days of the ancient Greeks and Romans.

46-64% Dry-Bulk Carriers and Barges are loaded with ore, gravel, coal, grain and similar products. The cargo is carried in dry, loose form and typically loaded and unloaded using chutes and tubes assisted by gravity. Unless they are desperate for coal or need the grain for food, most pirates ignore dry-bulk carriers. Unloading the plunder is just too difficult and even light damage to the ship (30% of its M.D.C.) could cause a spill.

65-80% Multipurpose Vessels simply carry more than one type of cargo. They are often tankers with normal cargo holds in addition to liquid-storage tanks, or standard cargo vessels that have been piled with drums or tanks to accommodate fuel. Sometimes they are cargo ships with small passenger sections and storage compartments for dry-bulk goods and all manner of crated or palletized cargo.

81-96% Passenger Ships deliver people to seaside destinations. While many people think of luxury cruise liners when they imagine passenger ships, there are only one or two such vessels on the entire Great Lakes, and even they are quite small compared to pre-Rifts versions. The average "passenger ship" is a small cargo vessel or fishing boat that has been pressed into the task. Its holds have been cleared out and replaced with cabins, bunks, hammocks and dining facilities. Most of these vessels are not carrying excited tourists to vacation getaways, but rather delivering laborers and technicians to locations, usually for a new job. The most common passengers are laborers, lumberjacks, miners, builders, construction workers, merchants, Operators and engineers, mercenaries, soldiers, adventurers, business people and, sometimes, diplomatic representatives. With no continental system of highways or railroads, most people seeking to travel to a new territory, kingdom, or city-state go by water when they can.

97-00% Ferry Boats are typically smaller than passenger ships, regional or local, and have established routes that they follow. As a rule, ferry boats carry people across a wide river or from the mainland to an island, and vice versa. Ferry boats can be thought of as "buses" that generally carry workers from home to work, or pedestrians from one location to another. Ferries are very low-value targets for pirates, as they are usually loaded only with people and light commercial vehicles, and most operate in heavily populated locations that have well-defended coastlines and whose waters are patrolled and protected. **Note:** There are ferries that run people from Escanaba to Manistique or Menominee, from Manistique to Beaver Island and from Saint Ignace to the islands in the Straits of Mackinac. There is also a ferry that runs from Escanaba to Gladstone, but one must have a special NG access pass to get on it.

Note: Of course, there are military patrol boats and other combat vessels on the Great Lakes and connecting tributaries, but pirates and raiders tend to avoid the law and the military, attacking only as an act of revenge or out of necessity; e.g. one or more tempting cargo ships are being escorted by combat vessels.

Step Two: Shipping Vessel Armaments

The Great Lakes of Rifts Earth are quite different from the Great Lakes of the Golden Age. Pirates, raiders and sea monsters are very real threats, and the occasional flight of Xiticix that drifts out over Lake Superior can also put nearby shipping at risk. Some

freighters are unarmed and take their chances, others are armed solely for self-defense, while others are heavily armed and still others are essentially just pirate ships or merc warships that happen to be in the midst of a legitimate cargo hauling or passenger job (or both).

00-10% No Weapons are featured on the ship. The defense of the vessel is up to the crew and their personal armaments. The typical merchant marine on the Great Lakes is armed with Northern Gun rifles and pistols, often favoring ion weapons for their ability to shoot into and under the water. Less than 2% of the crew has light to medium body armor available to them, provided they have time to suit up.

11-30% Light Armaments are carried on the freighter, primarily deck-mounted rail guns or laser cannons, and crewmen with heavy weapons. 1D4 rail guns and 1D4 crewmen with Northern Gun mini-missile launchers, in addition to other, light personal weapons, is all this vessel has to protect it. Around 5% of the crew have light to medium body armor available to them, provided they have time to suit up.

31-60% Medium Armaments with One Heavy Weapon have been incorporated into the ship's design. One naval gun like the NG-505 or an equivalent energy turret or cannon is mounted on the deck, along with 1D4+1 rail guns and 1D4+2 crewmen with mini-missile launchers or other heavy M.D. weapons. 10% of the crew have light to medium body armor and energy rifles, and one has power armor available to him, provided he has time to suit up.

61-80% Moderate Heavy Weapons are built into the freighter. Two naval guns, either one on each side or one in front and one in back, along with one mini-torpedo launcher, 1D4 rail guns and 1D4 crewmen with mini-missile launchers. 15% of the crew have light to medium body armor and energy rifles, plus two have power armor available to them, provided they have time to suit up.

81-90% Heavy Naval Guns and Torpedo Launchers are either hidden away in shipping crates or displayed prominently to ward off pirates. Either way, this ship is ready to tangle, probably an escort ship or pirate hunter. Armed with four naval guns, one on each side and one in front and one in back, along with two mini-torpedo launchers, 1D4+2 rail guns or energy cannons as secondary guns, and 1D4+3 crewmen with mini-missile launchers. 25% of the crew have medium to heavy body armor and energy rifles, plus 1D4+1 have power armor available to them, provided they have time to suit up.

91-00% Magic Defenses. Or a combination of magic and technological defenses. Techno-Wizard modifications are the most common, but a vessel may also be defended by 1D4 Warlocks, Elemental Fusionists, Line Walkers, Mystics, Ocean Wizards and other types of practitioners of magic (or creatures of magic). Of course, Northern Gun is not involved in the manufacture of water vessels or any merchandise that incorporates magic. However, what the purchaser does with the vessel after NG sells it is beyond the manufacturer's control.

Step Three: Ship's Crew

The number of crew aboard a ship can make a big difference in its viability as a target for piracy. Large crews also have a greater need for food, water and other supplies, however, and cost more to maintain.

00-19% Skeleton Crew: Just a handful of sailors are piloting this vessel; 1D4+4 crewmen with no specialists.

20-39% Light Crew: 1D4+7 crew, one of which has the First Aid skill at a proficiency of 70% or greater.

40-69% Standard Complement: 1D6+10 crew, one of which is a designated medic with Paramedic at 80% or greater.

70-89% Full Complement: 2D4+12 crew, plus a ship's Body Doc and an Operator, both at least 2nd level.

90-00% Extra Personnel: A full crew complement of 2D6+12 sailors are aboard, plus the ship's doctor, an Operator, two security experts (any Men at Arms O.C.C. or Wilderness Scouts, Psychics or mages), all at least 3rd level; and perhaps a Northern Gun surveyor or Loss Prevention Officer.

Step Four: Ship's Cargo

The type of freighter may help determine the likely type of cargo aboard, but with a few exceptions like obvious tanker ships, just about anything can be inside that cargo bay or under the tarp on deck. Here are some likely types of cargo. Since this is cargo on and around the Great Lakes, goods are most likely to be manufactured by or shipped to or from *Northern Gun/Ishpeming* and the *Manistique Imperium/Wellington*, but can also be any of the Coalition States (Iron Heart in particular), Free Quebec, and among other North American manufacturers and kingdoms. Magic items are surprisingly rare cargo, probably because they can be transported via magical means and because most items are handcrafted, not mass produced, keeping their quantities small. Splugorth/Atlantean goods are, likewise, rare in this part of the world. **Note:** Please feel free to substitute cargo with things not on the list and/or make the cargo much better defined.

01-03% Fuel. Typically one type.

04-06% Raw ore or coal.

07-09% Processed metal or metal goods. This can be metal bricks, ingots, sheets, etc. or goods such as chain, nails, spikes, pipe, etc.

10-12% Lumber. 01-40% unprocessed logs. 41-00% processed wood for buildings.

13-15% Livestock for eating. Can be any one or combination of the following: Cattle, cows, sheep, goats, pigs, and similar.

16-18% Livestock for riding or work. Can be any one or combination of the following: horses, mules, donkeys, or exotic riding animals (Fury Beetles, dinosaurs, etc.).

19-21% Textiles/Fabric. Bolts of material for making clothes and other fabric items; curtains, blankets, table cloths, etc.

22-24% Grain.

25-26% Furniture. All types.

27-29% Medical. Roll again: 01-33% Common medical supplies (bandages, antiseptic, aspirin, scissors, scalpels, tweezers, surgical needles, sutures, first-aid kits, and similar common medical tools, supplies and medicine). 34-66% Professional tools, basic equipment and medicine (antibiotics, painkillers, etc.) like you'd find at a pharmacy, clinic or field hospital. 67-00% Advanced medicine, tools and equipment like you'd find at a hospital, and may include a number of robot medical kits (any type), portable labs, Juicer harnesses and Juicer reload stock, and so on.

30-32% Linens. Blankets, quilts, sheets, towels and similar items. May be substituted with rope and wilderness supplies.

33-34% Household goods. Anything from kitchen items (cutlery, china and glassware, pots, pans, canning jars, spices, etc.) to

wastepaper baskets, plastic and glass containers, garbage bags, vacuum cleaners, mirrors, scissors, tape, glue, step stools, light bulbs, writing implements, notebooks, sketch books, stationary, craft items, picture frames, vases, buckets, soaps, dish rags, and so on.

35-37% Tools and hardware. A wide variety of tools and hardware items: shovels, picks, axes, cutting tools, pipe, electrical wire, nails, screws, duct tape, etc.

38-40% Generators and/or lighting and electrical materials. May include some solar-based items, but NO nuclear batteries.

41-42% Clothing. Work and common articles of clothing and/or shoes and boots.

43-45% Weapons: Common handguns, rifles and ammo (E-Clips if energy weapons). May be one type or crates of a wide range of weapons. 01-33% All S.D.C. items. 34-70% All M.D. weapons. 71-00% a combination of S.D.C. and M.D. weapons and ammo. NO heavy weapons.

46-48% Environmental body armor. May be one type or crates of a wide range of variety of different armor.

49-51% Weapons: Vibro-Blades. A selection of two or several types. May include a selection of conventional S.D.C. swords, knives and other melee weapons or tools (axes, picks, shovels, etc.).

52-53% Commercial vehicles or vehicle parts. All the same type, a few different types, or a wide selection of cars, vans, pickup trucks, small cargo trucks, jeeps, SUVs, motorcycles, snowmobiles, and so on, of various models. In the alternative, the cargo could be vehicle component parts, electric batteries or gasoline. 01-50% S.D.C. construction. 51-00% M.D.C. construction.

54-56% Weapons: Heavy M.D. weapons/military grade. 01-33% All one type of weapon and its corresponding ammo.

34-66% Mixed selection of heavy weapons (ion, plasma, particle beam, rail guns, etc.) and their corresponding ammo, but NO explosive ordnance. **67-00% Explosive ordnance only. Roll again:** 01-50% commercial explosives, dynamite and blasting caps. 51-00% *military ordnance* that may include one of the following or any combination of some or all: explosive hand-grenades, smoke grenades, riot control grenades (stun/flash and/or tear gas), rifle grenades, mini-missiles (all one type or an equal number of all types), short-range missiles, medium-range missiles, long-range missiles, shaped charges, fusion blocks (one type or a selection of all three).

57-58% Food. 01-25% Fresh produce (fruits and vegetables). 26-50% Meat (beef, pork, chicken, fish, etc.). 51-75% Cereal/noodles/bread. 76-00% Processed/canned foods and spices.

59-61% Vehicles: Hovercycles. A selection of hovercycles and/or other ground vehicles suitable for adventuring and wilderness excursions.

62-64% Camping/wilderness gear. One, a few, several or all of the following: Rope, cords, hand axes, handpicks, shovels, survival knives, basic tool kits, canteens, thermos, water skins, gasoline cans, gallon jugs, specimen containers, backpacks, knapsacks, satchels, bedroll, wire, duct tape, first-aid kits, simple sacks, tents, mosquito netting, insect repellent, small portable generators, flashlights, lanterns, portable stoves, compasses, fishing gear, hunting gear, animal traps, hunting gear, sun block, air filters, sunglasses, web vest, web belts with pouches (various sizes of pouches), and so on.

65-66% Contraband: Books. Books, magazines, artwork, audio books and digital files of such items and/or outlawed movies on disk or pre-Rifts artifacts, or alien goods that have been branded illegal by the CS.

67-68% Contraband: Magic. Techno-Wizard components (gadgets, wire, semi-precious stones, gems, etc.) and/or some TW devices. Other possibilities, though rare, could include magic items/TW creations from South America or Atlantis, or Tolkien Iron Juggernauts, TW vehicles, and TW war machines, or Federation of Magic Automatons, items from Lemuria or England, or even others worlds! Rare. G.M.s, use your discretion.

69-70% Contraband: Slaves. A hold full of 3D4x10 slaves or refugees (probably D-Bees, but can be humans, can be just women or children) being smuggled someplace.

71-72% Contraband: Livestock. Any number of exotic, alien, and dangerous animals.

73-74% Electronics. One, a few or all of the following: Computers, holographic projectors, digital cameras, video equipment, audio recording equipment, sound equipment, flashlights, lanterns, alarm clocks, toasters, microwave ovens, etc.

75-76% Communications gear. Short- and/or long-range radios, speakers, sensor systems, radar, sonar, and similar. In the alternative, can be surveillance equipment or electronic parts.

77-79% Vehicles: Boats. A selection of small sail and motor boats, may include canoes and kayaks.

80-82% Vehicles: Ground. A selection of M.D.C. wheeled and/or hover cargo hauling trucks (various sizes), and work/farm vehicles (tractors, cargo haulers, etc.). May include some robot cargo haulers.

83-85% Power armor. Probably a range of different types; with or without ordnance such as mini-missiles and rail gun rounds.

86-88% Robot drones. Probably a selection of different types of drones, and many include some robot cargo haulers that require a pilot, or computer hardware.

89-91% Vehicles: Combat robots. Depending on the size of the ship and the size of the robots, this could be as few as 2-8 of them or 12-48 (not likely to be more). They may all be one type or more likely, a mix of several different types of robots; with or without ordnance such as mini-missiles and rail gun rounds.

92-94% Vehicles: Combat vehicles. 01-33% Water craft. 34-66% Ground (tanks, APCs, and similar). 67-00% Aircraft (may include helicopters, jet packs, gliders and even some flying power armor). As with giant robots, depending on the size of the vehicles, there may be half a dozen to several dozen vehicles in cargo.

95-97% Cybernetics or Bionics. A wide range of cybernetic implants and bionic augmentation (arms, legs, armor, etc.). 01-20% chance of having some M.O.M. Crazy's augmentation or Juicer augmentation, harnesses and drugs.

98-00% A little bit of several different types of cargo. Any 1D4+2 of the above is the ship's cargo. Random roll for cargo as per above or pick them.

Step Five: Presence of Cargo

The status of that cargo can vary greatly, from fully-loaded ships just leaving the docks to empty vessels returning from long voyages, or partially full vessels making stops to two or more different locations. Well organized merchants will use their ships to make a profit on both legs of a trip, emptying their initial cargo

and taking on a shipment of secondary cargo with demand at the home port.

00-19% Empty: The ship's hold is completely barren save for a few empty crates or barrels. The crew are returning the vessel from a delivery or sending the ship on to dry dock, a new owner or new destination.

20-39% Partial Shipment: The freighter is less than half full; 1D4x10% capacity. Maybe it has already stopped at a port or two and is almost done with its voyage.

40-59% Half-Load: The vessel's cargo bay is loaded halfway, possibly to conserve fuel, possibly due to the logistics of the trip.

60-89% Standard Shipment: The ship is loaded with somewhere between 80% and 100% of its potential carrying capacity. It is likely just getting underway on its trip.

90-00% Overloaded: For maximum efficiency, this freighter has been packed as completely as possible, overloading it beyond its standard capacity (5D6% above and beyond 100% full load). There is little room aboard for anything else. Conditions are cramped and crowded, and the ship's overall speed and performance are diminished. Reduce Spd by 20% and suffers an additional -15% penalty to the piloting skill for evasive action and stunt maneuvers as well as for bad weather condition penalties.

Tugboats & Lake Escorts

Tugboats pull barges and disabled ships behind them, and sometimes two or more are necessary to get large vessels through tight shipping channels and enclosed waters. Some tugboats come heavily armed, and offer their services pulling barges, bundles of lumber and normal ships. The advantage they offer is protection. The crews of such tugs are usually tough fighting men, paid and trained to insure the well-being of their cargo or towed vessel. Perfectly functioning ships will sometimes hire *armed tugboats* and small to medium *weapon barges* (barges decked out with rail guns, mini-missile launchers, long-range, heavy weapon systems such as laser, ion and plasma cannons, and are likely to carry 1D4 giant combat robots as mobile weapon platforms plus 1D4 mercs clad in aquatic or flying power armor) to escort them safely through dangerous waters or past known hunting grounds for pirates, raiders and monsters, as well as combat zones. Moreover, if the ship being escorted should falter or run aground, a tug (and most barges) is able to provide its normal towing service.

Larger and better armed than tugboats are patrol boats and fighting ships that shepherd freighters and cargo vessels to their destination. Many privateer and mercenary groups offer lake escorts as a way of making extra money on the side, or as a way to keep inactive ships and crews busy and put a bit of coin in their pockets. Pirates may also take on escort duty, often as an excuse to fight their rivals. Sometimes pirate groups also con potential clients, using some of their forces for escort duty and have the rest play the part of the "pirate threat." They exchange a little gunfire and pop off a few smoke bombs, but never actually trade hits before the "evil pirates" are chased off by the heroic escort.

Some lake escorts look like the warships that they are, but others disguise themselves as humble freighters, barges or tugs. Such deceptions have deck guns hidden under tarps and inside crates where crewmen with missile launchers, laser cannons and mounted rail guns can quickly turn a seemingly "normal" vessel into a ship of war. Occasionally, these disguised escorts take to

the seas alone, playing the role of a freighter in distress. When pirates close in to take advantage of the seemingly disabled vessel, the freighter reveals its weapons, robots and power armor forces to hammer the pirates into oblivion – or to chase them away, hopefully, for a long while. This tactic may also be used to trick pirates and raiders into chasing and attacking the disguised (and armored) war ship, while the real freighters and cargo sneak off down safer shipping lanes. Some pirates also use this strategy, feigning innocence and distress only to attack when an unsuspecting ship comes offering its assistance. Relying on the kindness of strangers is definitely not a sure bet on Rifts Earth, but sometimes pirates do trick their victims this way.

Northern Gun Hovertrains

Just as Northern Gun uses the ships of the Great Lakes to distribute its products, *conventional trains* and *hovertrains* pulling boxcars function as the ships of the land.

A **hovertrain** is a series of independent hover platforms, each with its own hover systems but reliant on a powerful hover-locomotive for forward propulsion. The individual platforms are linked together by high-strength connections that include electrical outlets. When the entire arrangement gets moving, it becomes a modular transportation setup that can float over rough terrain, shallow bodies of water (ponds, marshland and streams), obstacles, debris, crashed vehicles and even scrub and small trees that would stop conventional land-based trucks.

Occasionally, a hovertrain will depart from the Ishpeming/Northern Gun mainland, heading through Manistique and up into *CS Iron Heart* before redirecting towards a small town or city-state. More often, though, hovertrains cross the Great Lakes aboard ships and delivered to strategic spots along the Great Lakes, where the train is off-loaded and continues on its journey across land. Hovertrains cannot cross deep water (20 feet/6.1 m or greater). From there the train travels outward from the coast to customers throughout the Midwest.

Passenger hovertrains are becoming more popular every year within Ishpeming and Manistique. Regularly scheduled trains follow the course of the IM highway, and trains depart almost daily from Ishpeming to *Escanaba*, *Manistique*, *Houghton* or *Ontonagon*. There are also small hovertrains with 2-6 cars that service lumber camps and mining sites, picking up ore, timber and supplies, as well as transporting workers. Within the City of Ishpeming/Northern Gun, there are several hovertrains that travel to all parts of the city picking up and dropping off passengers. There is a dedicated hovertrain that carries visitors from the *Visitors' Depot* five miles (8 km) outside the City of Northern Gun and back.

Within the nation and along well-established supply routes, the efficient hovertrain is used to transport cargo from the docks to all across the Upper Peninsula without having to worry about riding along a set of tracks. As noted elsewhere, however, conventional rail systems and trains are still used along the most traveled cargo routes from docks and warehouse districts to factories and cities across the U.P. The traditional train is cheap to make, power, use and maintain.

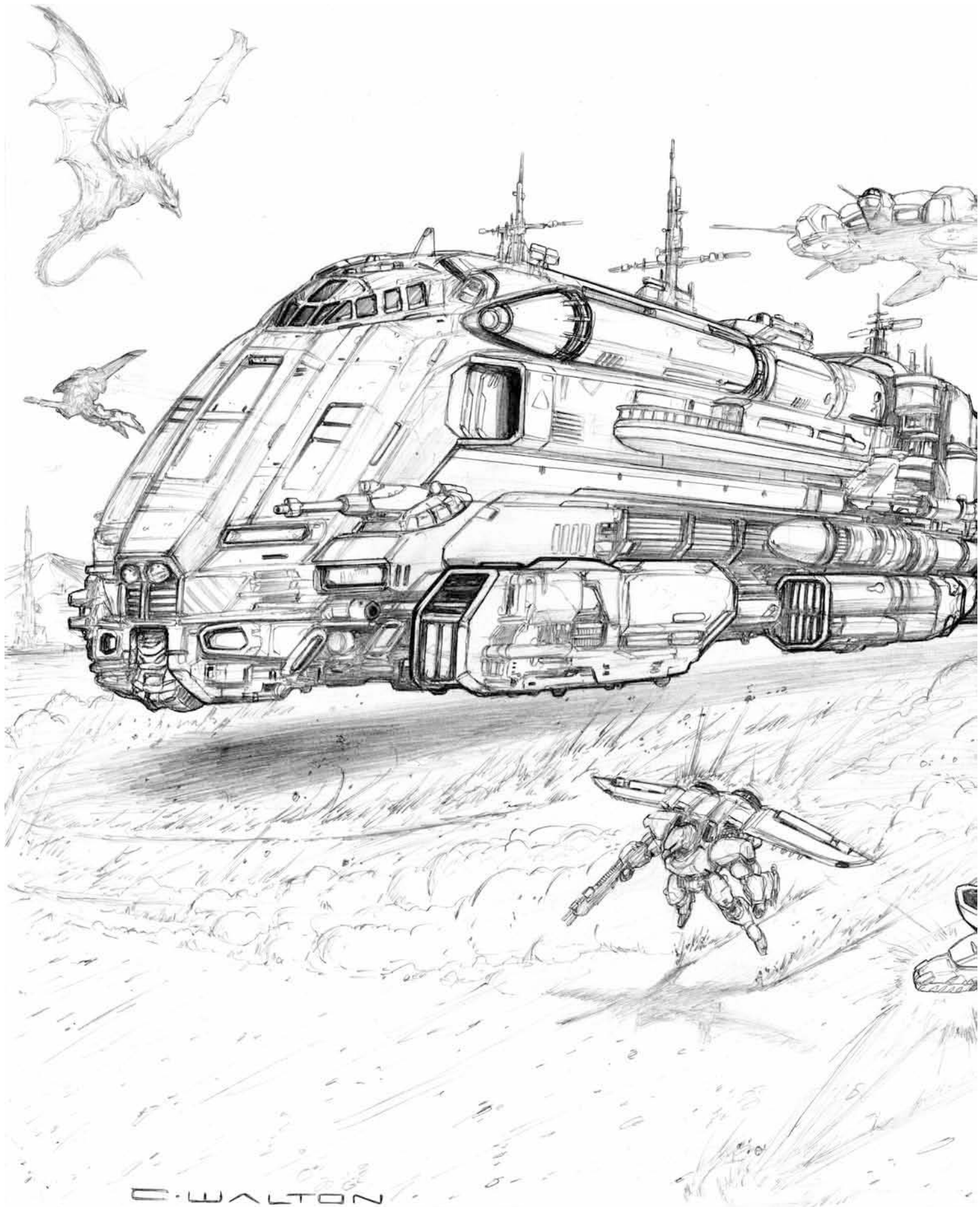



Hover Train Departure Points. Toledo in northern Ohio and Benton Harbor in western Michigan are both frequently used as departure points for hovertrains. Ships pull up to the shoreline and the hovertrains float right out onto the beach, wasting no time as they are already loaded up and able to head right off, inland, to their destinations. There are landing points throughout the old Canadian province of Ontario as well, like the **Georgian Bay** to the east of the Manistique Imperium.

The average hovertrain mission is designed to be quick and to the point. Hovertrains are an expensive investment, not even considering the huge amounts of cargo they may be carrying. Losing even one is a measurable blow to Northern Gun's supply network. They come heavily armored and well protected, yet many hovertrain expeditions are postponed due to severe weather, ley line activity or reports of hostile bandits, raiders, monsters and supernatural creatures.

Hovertrains traveling back and forth inside Ishpeming do not usually have defenses of any kind, but any leaving the Republic will always have weapon cars and/or be escorted by robots, power armor or other combat vehicles. Defensive cars are floating bunkers that provide protection for the rest of the train, as well as a better-armored target to soak up incoming fire and hold the attackers' attention. However, *giant combat robots* on open-air, flatbed hover train cars are starting to replace the static weapon cars. Combat robots are, in effect, walking bunkers or tanks that can fire from the train the same as a defensive bunker car, but can also go mobile as needed. This extra measure of mobility enables the combat robots to step off the train to engage and hold off attackers while the train continues on its way. In addition, they can stand or walk patrol while the hovertrain offloads cargo, stand guard over the train should it become disabled, or go off to find help, and investigate anything that looks suspicious.

Like cargo ships, the hovertrain usually drops off outgoing cargo, and picks up incoming cargo for its return trip. Also, while there are many established transit routes in the more civilized areas, the beauty of a hovertrain is that it can change its route, go around washed out roads and over fallen trees and debris, and take the best route that is most direct or safest, provided it has a clear path ahead of it.

Hovertrain Locomotive

Based on the same principle of Northern Gun's line of hovering cargo haulers, hovertrains expand on the concept by adding additional cargo cars and creating full supply trains and convoys pulled by a single, powerful main engine. *Hovertrain locomotives* are massive machines of incredible power, designed to pull hundreds of thousands of tons behind them floating on cushions of air. They are powered exclusively by nuclear cores, as gasoline, diesel and even Solid Oxide batteries fail to provide the necessary amount of raw power to propel the vehicle.

The locomotive's means of propulsion are four massive hover-fans that create lift. They are so powerful that any human or D-Bee up to 11 feet (3.3 m) tall who gets within 35 feet (10.7 m) has a 01-90% chance of being blown off his feet, and thrown back 1D4x10 feet (3 to 12.2 m), suffers 1D6 M.D., loses initiative and loses 2 melee attacks. (01-50% chance for larger beings.) Locomotives are gigantic monsters of science, and their upkeep, maintenance and customization is a matter of pride for the vehicle techs who work for the Northern Gun sales and distribution network. This means a great deal to the lead hovertrain designers who worked so diligently on it, **Gregory John Clark, Nicky Warren, David Chittim and Ross Simmerman.**

Model Type: NG-HCH-1228

Class: Hover Locomotive.

Crew: Three; one driver, one engineer and one gunner/backup driver.

M.D.C. by Location:

* Radar/Sensor Array (1, large) – 100

* Communications Array (1, small) – 50

* Headlights (2) – 10 each

Front Hover Fans (2, side) – 450 each

** Rear Hover Fans (2, side) – 350 each

Observation Deck (2, one on each side) – 100 each

Forward Weapon Turret (1) – 100

Reinforced Crew Compartment – 120

*** Main Body – 950

* A single asterisk indicates a small and/or difficult target to strike, requiring the attacker to make a “Called Shot,” but even then the attacker is -4 to strike.

** Destroying one of the hover fans reduces the vehicle’s speed by 30%. Destroying two or more of the fans reduces speed and altitude by 90% and inflicts a piloting penalty of -50%. It is highly recommended that the vehicle come to a complete stop and wait for a recovery team to haul it back for repairs or to receive repairs in the field.

*** Depleting the M.D.C. of the main body shuts the vehicle down completely, making it useless.

Speed:

Land: 250 mph (400 km) maximum speed for the locomotive itself. Reduced to 125 mph (200 km) when pulling more than three train cars or when fully loaded. Reduce speed further, to 60 mph (96 km), when overloaded beyond capacity (up to 40% more weight than should be allowed), or when carrying dangerous cargo.

Maximum hover altitude is 20 feet (6.1 m) even at 100% capacity, reduce to 12 feet (3.6 m) when overloaded.

Water: Not really; very limited. The HCH-1228 hovertrain can cross shallow bodies of water such as ponds, marshland and streams no deeper than 20 feet (6.1 m), but cannot actually ride on the surface of water and will sink like a rock in deep water.

Flying: None.

Statistical Data:

Height: 39 feet (11.8 m).

Width: 44 feet (13.4 m).

Length: 68 feet (20.7 m).

Weight: 98 tons.

Cargo: Locomotives have a small cargo area that includes a toilet, sink, a pair of fold-down cots for the crew, and is large enough for a few boxes of equipment, personal luggage or maybe a single motorcycle or small power armor suit.

Power System: Nuclear; average energy life is 15 years.

Cost: 97 million credits.

Weapon Systems:

1. Forward-Mounted Laser Turret (1): This weapon turret is mainly for defense and scaring away large animals. The turret can turn 120 degrees side to side and has a 25 degree up and down arc of fire. It can be fired by a dedicated gunner (with the bonus noted below) or by the driver (no bonus applicable).

Primary Purpose: Defense.

Range: 2,000 feet (610 m).

Mega-Damage: 4D6 M.D. per single blast.

Rate of Fire: Each blast counts as one melee attack.

Bonus: +1 to strike via laser targeting.

Payload: Effectively unlimited.

2. Sensor System Note: As per standard Robot Features.

Hovertrain Boxcar/ Flatbed/Passenger Cars

Hovertrains are designed to carry standard sized boxcars or cargo units. With roughly the capacity of 3-5 pre-Rifts semi-trailers, hovertrain boxcars are large enough to accommodate full-sized combat robots, armored vehicles like tanks, light aircraft and mountains of ore or grain. A hovertrain passenger car can carry more than one hundred passengers, depending on the comfort of the seating arrangements, and some models fit in a dining area, bar and toilet, and still have room to spare.

Flatbeds are used to carry the largest NG products, combat robots, tanks and planes. Sometimes, giant agricultural threshers and harvesters are carried aboard, or huge components for ships, wind turbines, power plants or factories. Whatever the cargo carried, it will be securely lashed-down to the flatbed to hold it steady in case of emergencies or sudden de-powering of the hoverdrives.

Lead Designers: *David Marble and Maffy.*

Model Type: NG-HCB-1B-Standard.

Class: Hover-Capable Boxcar.

Crew: None.

M.D.C. by Location:

Sliding Side Door (boxcar only) – 50

* Windows (40; 20 on each side; passenger cars only) – 5 each

** Hover Fans (4; two on each side) – 180 each

*** Main Body – 300

* A single asterisk indicates a small and difficult target to strike, requiring the attacker to make a “Called Shot,” but even then the attacker is -4 to strike (double when moving at 100 mph/160 km or faster).

** Destroying one or two of the hover fans reduces the locomotive’s speed by 5%. Destroying three or four fans reduces speed by 10% and adds a -2% penalty to the Piloting skill. Losing hover fans on several boxcars has a cumulative effect and can slow a hovertrain down considerably, even causing it to stop or leave behind boxcars that can no longer hover.

*** Depleting the M.D.C. of the main body knocks out the hover fans (see above) and any cargo (or passengers) contained within go spilling out and take 2D6 M.D. from the fall.

Speed:

Land: Towed by the locomotive. When detached, the boxcar can be made to hover and can be pushed or pulled by one giant robot (requires a Robot P.S. of at least 32) or by a heavy construction vehicle, tank or APC at a speed of 10 mph (16 km); half that when overloaded or carrying dangerous cargo. Maximum hover altitude is 20 feet (6.1 m).

Water: None.

Flying: None.

Statistical Data:

Height: 28 feet (8.5 m).

Width: 36 feet (11 m).

Length: 80 feet (24.4 m).

Weight: 10 tons empty, up to 210 tons fully loaded.
Cargo: An individual flatbed or boxcar can carry 200 tons of cargo, plus 40 tons overloaded.
Power System: Nuclear with a 15 year life.
Cost: 4 million credits, 4.5 million for the passenger car version.
Weapon Systems: None.
Sensor Systems: None.

Hovertrain Weapon Cars

Hovertrain "Weapon Cars" or "Defense Cars" were conceived by lead designers **Wayne Maynard**, **Frank Uhrmann** and **William McGoldrick**. They are hover boxcars with additional armor that have been turned into floating bunkers and laden with weapon systems. They are connected to hovertrains to provide protection against would-be attackers and monsters. A weapons platform that goes wherever the train goes and cannot be easily waylaid or misdirected. In addition to armor and weapons, most are designed to carry a squad or two of (10-20) troops inside that can respond to attacks made on the train and assailants who might manage to jump on board.

There are two ways in which Defense Cars are used. The obvious method is to have them stand out, their guns completely apparent. This way, attackers direct their focus on the Defense Cars, which are better armored and made to take hits. Firing on the Defense Car also gives away the attackers' position to the defenders themselves, increasing the accuracy of return fire. Hopefully, the very presence of a Defense Car will dissuade most bandits from attacking.

The second way to use the Defense Cars is to disguise them like regular boxcars. With the element of surprise, bandits can be apprehended, dispersed or destroyed, especially if they think their target is defenseless. Weapon turrets are hidden inside the innocent looking hover boxcar or under tarps or in other inventive locations, and revealed only at the last second. Security personnel with handheld weapons can also distribute themselves throughout the train, making sure the enemy never knows where the gunfire is coming from. And troops often include at least one or two squads of flying power armor or mercs with jet packs.

Model Type: NG-HCB-AD2

Class: Weapon Bunker Boxcar.

Crew: One communications officer and one gunner per weapon system (typically 2-6 weapon turrets) per car, with room for up to 20 security personnel, 10 in power armor.

M.D.C. by Location:

- * Sensor Array (1) – 35
- * Top Hatches (2) – 50 each
- * Side Hatches (4) – 100 each
- * Window Slits (8; four on each side) – 10 each
- Light Weapon Turret – 100
- Medium Weapon Turret – 150
- Heavy, Large Weapon Turret – 220
- Mini-Missile Launcher/Turret – 120
- ** Hover Fans (4; two on each side) – 180 each
- *** Main Body – 450

* A single asterisk indicates a small and difficult target to strike, requiring the attacker to make a "Called Shot," but even then the attacker is -4 to strike (double when moving at 100 mph/160 km or faster).

** Destroying one or two of the hover fans reduces the locomotive's speed by 5%. Destroying three or four fans reduces speed by 10% and adds -2% penalty to the Piloting skill.

*** Depleting the M.D.C. of the main body knocks out the hover fans (see above) and all weapons and sensor systems, and any cargo or troops contained within go spilling out and take 2D6 M.D. from the fall.

Speed:

Land: Towed by the locomotive. When detached, the boxcar can be made to hover and can be pushed or pulled by one giant robot with a P.S. of at least 32, or by a heavy construction vehicle, tank or APC at a speed of 10 mph (16 km). Maximum hover altitude is 20 feet (6.1 m).

Water: None.

Flying: None.

Statistical Data:

Height: 28 feet (8.5 m).

Width: 36 feet (11 m).

Length: 80 feet (24.4 m).

Weight: 30-40 tons fully loaded.

Cargo: The Defense Car has a locking gun rack for the security personnel, 20 fold-down seats and a dozen lockers for personal belongings.

Power System: Nuclear with a 15 year life.

Cost: 15-22 million credits depending on the number and types of weapon systems.

Weight: Around 40 tons.

Weapon Systems:

A total of three heavy weapon systems, or six medium, or nine light ones. However, most weapon cars have a combination of weapon systems. The most common combinations are as follows:

A. One heavy weapon system, two medium and 2-3 light weapons systems per car.

B. Two heavy weapon systems and two medium.

C. Two heavy, one medium and 2-3 light weapon systems.

D. Four medium weapon systems and 2-3 light ones.

Turret Note: All weapon are cannons mounted inside a turret. All have 180 degree side to side rotation and a 45 degree up and down arc of fire. M.D.C. by type: Light Turret: 100 M.D.C. Medium Turret: 150 M.D.C. Heavy Turret: 200.

Available Weapon Systems for Defense Bunker Hovercars:

1. Light Laser Cannon Turret: Considered to be a light weapon system, but is probably the Defense Car's main long-range weapon.

Primary Purpose: Defense.

Secondary Purpose: Anti-Armor.

Range: 2,000 feet (610 m).

Mega-Damage: 3D6 M.D. per blast.

Rate of Fire: Each blast counts as one attack.

Payload: Effectively unlimited.

Cost: 2 million credits.

2. Medium Laser Cannon Turret:

Primary Purpose: Defense.

Secondary Purpose: Anti-Armor.

Range: 3,000 feet (914 m).

Mega-Damage: 5D6 M.D. per blast.

Rate of Fire: Each blast counts as one attack/action.

Payload: Effectively unlimited.
Cost: 8 million credits.

3. Heavy Laser Cannon Turret:

Primary Purpose: Defense.
Secondary Purpose: Anti-Armor.
Range: 4,000 feet (1,219 m).
Mega-Damage: 1D4x10 M.D. per blast.
Rate of Fire: Each blast counts as one attack/action.
Payload: Effectively unlimited.
Cost: 15 million credits.

4. Mini-Missile Launcher Turret:

Considered to be a *medium* weapon system.

Primary Purpose: Anti-Armor.
Secondary Purpose: Anti-Personnel.
Range: One mile (1.6 km).
Mega-Damage: Varies with missile type. Plasma (1D6x10 M.D.) and Armor Piercing (1D4x10 M.D.) are standard.
Rate of Fire: One at a time or in volleys of two, four or six.
Payload: 48 missiles.
Cost: 2 million credits, with one payload of missiles.

5. Light Ion Cannon Turret:

Primary Purpose: Defense.
Secondary Purpose: Anti-Armor.
Range: 1,500 feet (457 m).
Mega-Damage: 4D6 M.D. per blast.
Rate of Fire: Each blast counts as one attack.
Payload: Effectively unlimited.
Cost: 6 million credits.

6. Medium Ion Cannon Turret:

Primary Purpose: Defense.
Secondary Purpose: Anti-Armor.
Range: 1,800 feet (548.6 m).
Mega-Damage: 6D6 M.D. per blast.
Rate of Fire: Each blast counts as one attack.
Payload: Effectively unlimited.
Cost: 8 million credits.

7. Heavy Ion Cannon Turret:

Primary Purpose: Defense.
Secondary Purpose: Anti-Armor.
Range: 2,000 feet (610 m).
Mega-Damage: 1D4x10+6 M.D. per blast.
Rate of Fire: Each blast counts as one attack.
Payload: Effectively unlimited.
Cost: 12 million credits.

8. Medium Plasma Cannon Turret:

Considered to be a *heavy* weapon system.

Primary Purpose: Defense.
Secondary Purpose: Anti-Armor.
Range: 2,000 feet (610 m).
Mega-Damage: 6D6 M.D. per blast.
Rate of Fire: Each blast counts as one attack.
Payload: Effectively unlimited.
Cost: 14 million credits.

9. Heavy Plasma Cannon Turret:

Primary Purpose: Defense.
Secondary Purpose: Anti-Armor.
Range: 2,000 feet (610 m).

Mega-Damage: 1D6x10 M.D. per blast.
Rate of Fire: Each blast counts as one attack.
Payload: Effectively unlimited.
Cost: 22 million credits.

10. Rail Gun Turret:

Considered to be a *heavy* weapon system with superior range, but finite ammunition.

Primary Purpose: Assault and Anti-Armor.
Secondary Purpose: Anti-Aircraft and Defense.
Range: 4,000 feet (1,219 m).
Mega-Damage: 1D4x10 M.D. per 40 round burst.
Rate of Fire: Each burst counts as one melee attack.
Payload: 6,000 rounds which provide 150 single bursts.
Cost: 1.4 million credits plus ammo at around two credits per round.

11. Medium Particle Beam Turret:

Considered to be a *heavy* weapon system, with short range.

Primary Purpose: Defense.
Secondary Purpose: Anti-Armor.
Range: 1,600 feet (488 m).
Mega-Damage: 1D4x10+8 M.D.
Rate of Fire: Each blast counts as one melee attack.
Payload: Effectively unlimited.
Cost: 20 million credits.

12. Heavy Particle Beam Turret:

Heavy damage, good range.

Primary Purpose: Defense.
Secondary Purpose: Anti-Armor.
Range: 2,000 feet (610 m).
Mega-Damage: 1D6x10+10 M.D. per blast.
Rate of Fire: Each blast counts as one melee attack.
Payload: Effectively unlimited.
Cost: 35 million credits.

13. Short-Range Missile Launchers:

Considered to be a *heavy* weapon system.

Primary Purpose: Assault.
Secondary Purpose: Anti-Missile and Defense.
Range: Five miles (8 km).
Mega-Damage: Varies with the missile type used. Standard load is Armor Piercing (2D6x10 M.D. to a 5 foot/1.5 m radius) or Plasma (2D6x10 M.D. to a 15 foot/4.6 m blast radius).
Rate of Fire: One at a time or in volleys of two, three or four per launcher.
Payload: 6 total.
Cost: 6.5 million credits with one payload of missiles.

14. Optional: Troop complement.

10 troops per squad. Cost: Varies per type of troop. See merc jobs.

15. Sensor System of Note:

Same as the standard robot features.

Random Hovertrain Generation Tables

Number of Boxcars

01-10% 2
11-20% 3
21-30% 5
31-40% 6
41-50% 7

- 51-60% 8
- 61-70% 10
- 71-80% 12
- 81-90% 14
- 91-95% 16
- 96-00% 18 (the maximum suggested number)

Train Status

01-20% Empty: This train is returning from a delivery or has yet to receive its cargo. It may be on the way back to a hovertrain depot for repairs or heading back to work after having repairs, upgrades or modifications completed. Other than the locomotive and the train cars themselves, there is nothing of value except for a few empty boxes and a few basic hand tools.

21-40% Passenger Train: Passengers make up the payload, and the majority of the train's cars are specialized passenger cars. In the more civilized reaches of Ishpeming, Escanaba and Manistique, passenger hovertrains include a club car with a restaurant and bar, and sometimes overnight cars with sleeping accommodations; uncommon considering most trips seldom take more than a couple hours.

41-55% Partially Loaded: The train is only partially loaded; half the boxcars are empty. It could have unloaded most of its cargo already at other destinations or be traveling under capacity for weight reasons or a hasty scheduling.

56-75% Mostly Loaded: This train is loaded most of the way (2D6+66%) with Northern Gun gear. There is still room for more, but this represents the normal packing job done by NG employees.

76-85% Fully Loaded: With little or no room to spare, this train is headed towards a busy sales outlet or filling an order at max capacity. Most trains traveling back and forth between Escanaba and Ishpeming are fully loaded to minimize the necessary number of trips. A full load means maximum speed is only 125 mph (200 km).

86-00% NG Products – Overloaded: In addition to a full internal payload, extra equipment has been stowed on the top or sides of the train. Overloaded by 1D4x10%. This train is forced to travel at 60 mph (96 km) for safety and engine stress reasons, and due to the immense amount of forward momentum that has to be halted when braking. The slow speed and lower altitude makes the hovertrain an easier target open to attack.

Onboard Defenses

01-25% None: There are no defenders accompanying the train or Defensive Cars that are part of it. That doesn't mean the crew is not armed with personal weapons, however, and even inside Ishpeming, most train conductors and crewmen carry light Mega-Damage weapons and a baton or club (does 1D6 or 2D4 S.D.C. damage).

26-35% Light Security Detail: 1D4+4 hired mercenaries or security guards ride along with the train. They are likely to be heavily armed and clad in M.D.C. body armor, but may be disguised as crew members or passengers with concealed weapons or bionics; heavy weapons and armor stowed elsewhere.

36-45% Medium Security Detail: 1D6+6 mercs or security guards, or 1D4+2 Loss Prevention Officers, ride along with the train. They are all heavily armed and clad in M.D.C. body armor,

or they may be disguised as crew members or passengers with concealed weapons or bionics; heavy weapons and armor stowed elsewhere.

46-55% Heavy Security Detail: 1D6+1 mercs or security guards all heavily armed and clad in M.D.C. body armor, 1D4+2 Robot Pilots in flying power armor, plus 1D4+1 Loss Prevention Officers, ride along with the train. Only the latter may be disguised as crew members or passengers with concealed weapons or bionics; heavy weapons and armor stowed elsewhere.

56-75% Defensive Car: A single Defensive Car is part of the train, likely right behind the locomotive, but may be in the center or placed as the caboose, as well. There may be only one, but even one Defensive Car is a hovering fortress, not to be trifled with, and generally has guards/soldiers aboard in addition to the train's normal crew. See the Defensive Car section for more details.

76-90% Strong Defense: Three Defensive Cars are included. One behind the locomotive, one at the center, and another at the rear. Each has a full complement of 10 heavily armed mercs and 10 power armor-clad troops.

91-00% Heavy Defense: 1D4+3 Defensive Cars protect the train, one behind the locomotive, one at the end in the caboose position and the rest scattered throughout. With this much security, the train's defenders are alert and well armed, and plenty in number.

Hover Train Escorts

In addition to, or instead of, fortified Defensive Cars, the hovertrain may be escorted by hired protectors on hovercycles, rocket bikes, skycycles or flying power armor.

01-15% No Escort: The train is on its own. Of course, some trains equipped with Defensive Cars don't need escorts at all. The train might also be meeting up with its escort somewhere ahead, and could radio for help if attacked.

16-30% Hovercycle Outriders: 1D4+4 "outriders" escort the train, or follow closely behind. Half are on hovercycles, half on rocket bikes, with the fastest scouting ahead with their greater speed and maneuverability, and the rest accompanying the train. They can also move up and down the length of the train to respond to specific threats, and there is probably room aboard for them to stow their vehicles for portions of the trip, so just because outriders are not immediately apparent does not mean they can't appear at any moment.

31-50% Flying Escort: Flying Power Armor. 1D4+2 Robot Pilots in flying power armor escort the train flying along side, above and ahead.

51-60% Flying Escort: Aircraft. 1D4+2 combat helicopters, Sky Cycles or similar aircraft (or combination of them) escort the train, sometimes flying ahead to scout the frontier, before doubling back to have presence as escorts.

61-75% Power Armor and Aircraft Flying Escort: 1D6+4 Robot Pilots in flying power armor and 1D4+2 aircraft (combat helicopters, Sky Cycles, rocket cycles or similar aircraft) escort the train. Power armor hang low, close to the train, the aircraft flying higher up to see more of the surrounding terrain and what lays ahead.

76-00% Combat Robot Escort: Rather than have an armored Defense Car, the train has one, two (or more) flatbed boxcars, each carrying two combat robots. When an attack comes, the ro-

bots fire their weapons just as a Defense Car would. The difference is, the combat robots can turn in any direction, have the full capabilities of their 'Bot, and can actually step off the flatbed car when the train stops, or leap off when it is moving at speeds 50 mph (80 km) and slower, to stay behind to engage the enemy, block a path or give chase. Likewise, the robots can scout ahead or position themselves, concealed among trees or behind debris or nearby buildings, and even underwater, to lay in wait and ambush any would-be attackers. They can then join the train at a pre-arranged location. In the alternative, tanks or APCs with troops can fill a similar role, but large and giant combat robots are almost always preferred. The **Gunbot, Bigfoot, Buffalo, Gunwolf, Grizzly, Hunter Mobile Gun, Thundercaster** and **Volcano** are among the most popular choices for such operations, but almost any will suffice.

Specific Boxcar Type

Use for determining the status of single hovertrain cars. **Note:** Every hovertrain includes a locomotive for propulsion.

01-10% Defensive Car

11-20% Fuel Car

21-30% Passenger Car or Flatbed Boxcar

31-00% Cargo Boxcar

Cargo On Board

Use the same table as listed under Ship Cargo earlier in this section.

Northern Gun Robots

By Matthew Clements, Carl Gleba & Kevin Siembieda

Some additional text and ideas by Carmen Bellaire & Charles Walton

Of all the things the industrial giant manufactures and sells, NG is probably most famous – some might say notorious – for its *giant robots*. These are big, heavy, manned vehicles with a pilot, and often a copilot, gunner and even room for one or more passengers. Though the war machines get the most attention, Northern Gun also sells a number of robots designed for exploration, adventuring, camping, medical assistance, cargo hauling and other non-combat functions.

Many of the robots presented in this section have been released in just the last 1-5 years, and have been met with raves from NG customers everywhere.

Alphabetical List of NG Combat Robots

Beachmaster Amphibious Combat Robot
 Behemoth Explorer
 Behemoth Super-Explorer
 Bigfoot Combat Robot
 Bison Combat Robot
 Blocker Combat Robot
 Bruiser Combat Robot
 Buffalo Combat Robot
 Bulldog Combat Robot
 Grizzly Combat Robot
 Gunbot Combat Robot
 Gunwolf Combat Robot
 Hunter Mobile Gun NG-V7 'Original'
 Hunter Mobile Gun NG-V7, Block IV (Upgrade)
 Megabot NG-M57-2N1 (Multibot reboot)
 Mini-Mobile Medical Robot NG-MMB-02 'Junior'
 Mobile Medical Robot NG-MMB-01 'Big Papa'
 Multibot NG-M56 'Original'
 Ogre EXC-17 Explorer & Construction
 Okemos Explorer
 Scorpion Battler EX-V50 Combat & Construction
 Sunfire Combat Robot
 Super Labor Robot NG-V10 'Original'

Super Max NG-8000 Combat Robot
 Thundercaster Combat Robot
 Viking Combat Robot
 Volcano Combat Robot
 (Drones and Cargo Haulers appear in NG-2.)

All NG Robot Vehicles have the following standard features:

1. Nuclear Power Pack: The nuclear power supply has been standard for generations and has an effectively unlimited fuel capacity and power source. Average life: 12-20 years.

Alternative Fuel Systems for Robots. However, Northern Gun has, in the last year, introduced *Solid Oxide Fuel Cell* and *Electric Battery* systems. The value in power supplies other than nuclear is reduced cost in the short-term, with the alternative systems reducing the cost of most robots by 6-15 million credits, depending on which alternative is selected. **The downside** is a finite power supply that needs replacement or recharging much more often.

Nuclear: 12-20 years average life.

Solid Oxide Fuel Cell: 4 weeks in robots, heavy and armored vehicles and aircraft; 8 weeks in most man-sized power armor (9 feet/2.7 m and smaller), hovercycles, rocket bikes and light vehicles.

Electric Battery: 96 hours (4 days) in robots, heavy and armored vehicles, and aircraft; 144 hours (6 days) for most man-sized power armor, hovercycles, rocket bikes and light vehicles.

Note: Nuclear is still the default power system, and some of the biggest, heaviest robots like the Behemoth and Grizzly must use nuclear power. The same is true of most ships.

2. Radar: Simple radar can identify and track up to 48 targets simultaneously at a range of 30 miles (48 km).

3. Combat Computer: Calculates, stores, and transmits data onto the heads-up display (H.U.D.) of the pilot's helmet. It is tied to the targeting computer.

4. Targeting Computer: Assists in tracking and identification of enemy targets, 30 mile range (48 km).

5. Laser Targeting System: Assists in the selection and focusing of specific targets and adds a bonus of +1 to strike when using long-range weapons. Does not apply to hand to hand combat or power armor.

6. Radio Communication: Wideband directional radio communication system with an effective range of about 500 miles (800 km).

7. Built-in Loudspeaker: 80 decibels.

8. External Audio Pickup: A sound amplification listening system that can pick up a whisper 300 feet (91.4 m) away.

9. Spotlights: Most robots will have at least one or two spotlights. Typical range is 600 feet (182 m).

10. Ejector Seat: In case of an emergency, the pilot and crew can be instantly ejected (1,000 feet/305 m) and parachute to safety.

11. Self-Destruct: A last resort measure to prevent one's robot from being captured by the enemy. The explosive damage is fairly self-contained, destroying most of the internal systems with 2D6x10 M.D. However, it is very likely, 01-89% chance, that the nuclear power system is spewing forth deadly levels of radiation!

12. Voice Actuated Locking System: The robot's access hatch is sealed by an automatic locking system. A six digit spoken code programmed to a specific voice(s) pattern (six voice memory) is standard operating procedure. A manual key pad is provided in case of system failure/override.



13. Reinforced Environmental Pilot Compartment: Seating in a pilot compartment can vary widely from robot to robot, and typically ranges from just the pilot, to the cockpit for the core crew (usually 2-4 people). It is reinforced to protect the people inside from injury when the robot's main body M.D.C. is reduced to zero or below. It is airtight, pressurized and suitable for use in all hostile environments, including underwater (maximum depth is 800 feet/244 m unless stated otherwise) and even in outer space. **Note:** A reinforced pilot compartment means that even when the main body of the robot vehicle is reduced to zero or below, the inner pilot compartment inside the robot is protected. Systems are dead and the compartment is revealed and vulnerable to subsequent attacks (so get out!), but the pilot (and crew?) are safe for the moment. This compartment is where the pilot, and often core crew members (copilot, communications officer) sit and operate the robot. It is only when the main M.D.C. is gone that the reinforced pilot compartment is revealed and vulnerable to

further attack. If no reinforced pilot compartment is indicated, it means there is *none*, but this is uncommon among NG, CS, Titan and Triax robot vehicles. **Note:** Gunners who sit inside turrets or away from the pilot's cockpit do not have such protection.

14. Computer controlled life support system.

15. Internal cooling and heating/temperature control.

16. Air purification and circulation systems, gas filtration and a humidifier/dehumidifier automatically engages when needed. Can recirculate breathable air for up to four weeks before getting too stale to breathe.

17. Computer controlled, independent oxygen supply and purge system that automatically engages in low oxygen or contaminated air environments. Twelve hour oxygen supply.

18. Insulated, high temperature resistant shielding for up to 400 degrees centigrade (752 F). Normal fires do no damage. Nuclear, plasma, and magic fires do full damage.

19. Radiation shielded.

20. Polarized and light sensitive/adjusting tinted windows and viewports.

Alternative Fuel Systems

Solid Oxide Fuel Cells

One problem with many of Northern Gun's most sophisticated creations is the high-cost of their power systems. Nuclear power cores are difficult to manufacture under any circumstances and add significantly to the base price of already expensive vehicles, robots, power armor systems and aircraft. For years, an alternative has been sought.

Sophisticated electric batteries are an option, but they require access to reliable power generation to recharge. For military units in the field and especially mercenaries and independents, this can often be a problem. (Vehicles with nuclear power plants can be rigged to do the job, but the charging process takes 1D4+1 hours, limits the vehicle doing the charging to only 10% of its normal speed and renders it totally unable to fire energy weapons.) Even the best batteries produced by Northern Gun can only offer roughly 100 hours of service life and are only fit for certain vehicles and light armor. This may not be a problem for city guards and local militia units, but for high-value customers like mercenaries and state armies, something superior is necessary.

Luckily, a solution was found amongst the pre-Rifts technological remains that Northern Gun is both literally and metaphorically built upon. Certain pieces of mining equipment and civilian vehicles left behind from the Golden Age were powered not by nuclear cores, but by sophisticated Solid Oxide fuel cells. This technology is a remnant, a holdover from the end of the age of fossil fuels, and had much appeal to the Research & Development branch of NG.

The fuel cells are relatively cheap and very versatile, and can be manufactured using almost any fossil fuel, ranging from diesel to gasoline to natural gas, coal gas and even alcohol. Unlike conventional gasoline and diesel engines, Golden Age Solid Oxide cells have the capability to power even energy hogs like combat robots and high-speed hovercraft. They provide enough energy to utilize a vehicle or robot's built-in energy weapons without worrying about draining the battery. For the last few years, Northern Gun has been extensively marketing 'Solid OX' as a cheaper al-

ternative to nuclear power systems and making Solid Oxide fuel cells available wherever NG products are carried.

Solid Oxide cells are quite simple to use. Insert a fresh fuel cell into the vehicle, armor or robot's cell port, twist the handle to activate, and you're done! The cell will provide robots and large vehicles with energy for approximately four weeks (28 days) before running out, or roughly eight weeks (56 days) for power armor, hovercycles and light vehicles, after which it will need to be returned to an official Northern Gun outlet to be *recharged* and *rebuilt*. NG buys back used but undamaged fuel cells for 15% of their list price, a nice incentive for customers to return their cells which also saves Northern Gun when it comes to overall manufacturing costs (and is good for the environment).

Solid Oxide fuel cells come in two types, Standard and Heavy-Duty. Standard fuel cells are for hovercycles, personal vehicles, light power armor and devices like jet packs. Heavy-Duty fuel cells are for tanks, combat robots, power armor with heavy energy weapons and large vehicles and aircraft.

Standard Solid Oxide Fuel Cell – For Power Armor

Weight: 42 lbs (19 kg).

Duration: 1,400 hours (approximately eight weeks of constant use).

Protective Casing: 15 M.D.C.

Cost: 40,000 credits.

Heavy-Duty Solid Oxide Fuel Cell – For Robots

Weight: 221 lbs (99.5 kg).

Duration: 700 hours (approximately four weeks of constant use).

Protective Casing: 30 M.D.C.

Cost: 120,000 credits.

The Dangers and Limitations of Solid Oxide Fuel Cells.

The first thing anyone who handles Solid Oxide fuel cells realizes is that they run hot. The average temperature of a Solid OX cell in use is 1,000 degrees C (1,832 F)! The cells tend to stay hot for a long time after being powered down as well, so working with them requires special heavy equipment, welder's gloves, masks and sometimes even heat suits. Touching an exposed hot fuel cell will inflict 1D4 M.D. to Mega-Damage creatures and 2D4x10 S.D.C. to human beings. For humans, these are third-degree burns and will result in permanent scarring.

Solid Oxide fuel cells are also less bountiful in their reserves of power than the nuclear cores that many customers are accustomed to. Using a Solid OX powered vehicle or robot to charge another vehicle's batteries will drain 50% of its energy life. Armor, robots and military vehicles that have replaced non-energy ballistic weapons like rail guns and missile launchers with energy weapons or added extra energy weapons will also put a strain on the system, cutting the fuel cell's life span by 25%.

In addition to their functional limitations, Solid Oxide fuel cells are also extremely volatile and will react explosively if their outer casing is ruptured. Reduce the M.D.C. of a fuel cell to 5 M.D.C. or less and there is a 50% chance of it exploding every minute (4 melee rounds). Reduce it to zero and it explodes immediately. A Standard Solid OX fuel cell does 4D6 M.D. to everything in a 6 foot (1.8 m) radius. The Heavy-Duty Solid OX cell does 1D6x10 M.D. to a 10 foot (3 m) radius. If a fuel cell is exposed and it is detonated while still inside the vehicle, all damage is done directly to the main body and utterly destroys

the power system, requiring complete replacement and extensive repairs (1D4 million credits and days for repairs).

Converting Vehicles to Use Solid Oxide Fuel Cells

In addition to selling the fuel cells and offering fuel cell systems as an option on new products, Northern Gun also offers conversion packages for older NG equipment and even competitors' models. They are more than happy to convert the vehicles of rival companies to use their Solid Oxide systems, for which they are the only provider of fuel cells. They even offer *free installation* at most official NG stores. Northern Gun envisions a day when Solid OX has replaced nuclear power packs as the most common and affordable vehicle fuel system in North America.

The conversion kits that they produce have been appearing at third party arms merchants and in the hands of the Black Market, just as Northern Gun intends. They are relatively simple to install, pre-designed to be partially modular and to fit right into the cavity left behind when a standard nuclear core is extracted. The job can be handled by any skilled Operator (01-94% chance of success) with access to heavy machinery or an assistant with Robotic or Supernatural P.S. to do the heavy lifting. Removing the old nuclear power pack safely is always the hardest part of the job.

Solid Oxide Conversion Kits

Jetpack or Small Power Unit: 25,000 credits.

Motorcycle or Hovercycle: 30,000 credits.

Personal Vehicle, Hovercar or ATV: 45,000 credits.

Power Armor: 75,000 credits. Includes built-in storage for one spare, Standard Solid OX fuel cell.

Combat Robots & Patrol Boats: 125,000 credits. Includes built-in storage for one spare, Heavy-Duty Solid OX fuel cell.

Aircraft, Military, Large Construction Vehicles & Large Boats, Barges and Small Ships: 200,000 credits.

NG's Electric Batteries

Northern Gun has always offered certain hovercycles and small vehicles with rechargeable electric batteries as a power source, but since the premiere of the **Gladius exoskeleton** several years ago, Northern Gun's engineers have become proficient with designing large batteries and charging systems. Most Northern Gun vehicle and robot designs now offer electric batteries as a *power option* with a standard 96 hour field life, good for roughly 4-12 days of use in the field depending on the level of exertion. This lifespan doubles to 144 hours for light units like most man-sized power armor, light robot drones, exoskeletons and hovercycles. These smaller units require a single battery, power armor and medium-sized vehicles need two batteries, and combat robots and larger vehicles require four batteries connected in series. NG offers recharging services for a pittance (takes three hours using specially designed NG recharging stations, 5 hours via other means, to fully charge a system's batteries, no matter how many batteries the system uses), and often recharging is thrown in free for customers purchasing other products.

Electric batteries are very versatile and can be recharged from almost any medium to heavy generator, power grid or vehicle/

robot/power armor with a nuclear power supply. Batteries can also be used as portable power generators while their charge lasts, capable of running a building's lights or powering up a few limited mechanical systems. Connecting a battery to a power grid or trying to use it as a replacement for a real generator requires an Operator or someone with the *Electrical Engineer* or *Electricity Generation* skill, otherwise it will quickly cause an overload and render the battery useless, totally dead and unable to be recharged.

NG Electric Battery Power System

Weight: Each battery weighs roughly 31 lbs (14 kg).

Duration: 96 hours or 4 days of continuous use in robots and heavy vehicles. 144 hours or 6 days of continuous use in most man-sized power armor (9 feet/2.7 m and smaller), hovercycles, rocket bikes and light vehicles.

Protective Casing: 10 M.D.C.

Recharge Cost: 200 credits per battery at most NG stores and other weapon dealers and stores. However, a friend or good Samaritan may recharge a battery at no charge whatsoever. Takes 5 hours to charge a battery to full power (3 hours at an NG outlet).

Cost: 90,000 to install the electric battery system and 25,000 credits per each NG electric battery used, and for replacement batteries. Otherwise, the life of an electric battery under normal use is five years; 1D4 years under combat conditions.

Beachmaster

Amphibious Assault Robot

The intimidating metal monster that is the Northern Gun Beachmaster is the creation of the design team of **Derrick Landwehr, Robert Steiner, Trevor Fitch** and **Matthew Clements**. It is the larger, combat robot counterpart to the *Beach-Stormer power armor*. It has reliable underwater propulsion and navigation systems, and is made to rise up out of the sea during amphibious assaults and storm enemy coastal positions as well as to attack ships in deep water.

In the dark depths of the Great Lakes or the open ocean, the Beachmaster is an ambush predator. When a suspected enemy vessel is indicated approaching on sonar, a unique ballast system enables the Beachmaster to slowly rise from the lake floor or ocean depths as well as at harbors and docks. A favorite tactic is for the Beachmaster to climb up onto a ship, or hang from the side of one ship while blasting away at another. The Beachmaster is not terribly fast compared to certain submarines or aquatic magic vehicles, but is big and tough enough that it can usually take on anything that it can catch up to. Its undersea weapons are mainly short-range, and feature many dual-capability designs.

Once on land, the Beachmaster lives up to its name, providing a pivotal armored fist for amphibious infantry to rally behind and follow into battle. With its heavy weapons, it can neutralize patrol boats, towers, rail gun nests, and bunkers, as well as infantry troops. Its flamethrower, in fact, is one of the weapons used for flushing out bunkers and scattering troops. The Beachmaster's hands, large and powerful for close combat purposes, are also designed to be effective in climbing and engineering operations. The robot can dig up enemy positions or scoop sand and soil into makeshift ramps to assist tracked or wheeled vehicles in com-

ing ashore during amphibious landings. To lead the charge, the Beachmaster tears up whole lines of barbed wire defenses, plows through tide-walls and earthworks and can engage monsters and other robots in hand to hand combat. To assist in such operations, the Beachmaster has a chainsaw on its left forearm and an array of weapon systems.

Initial sales of Beachmaster units to privateer groups, coast guards and even suspected pirates are all looking very promising.

Model Type: NG-V36

Class: Amphibious Assault Robot.

Crew: 2; one pilot and one copilot/gunner. The robot is designed so that a single pilot can operate it if necessary.

M.D.C. by Location:

Legs (2) – 280 each

Arms (2) – 160 each

* Hands (2) – 80 each

* Blue-Green Chest Lasers (2) – 40 each

* Heavy Flamethrower (1, right forearm) – 80

* Chainsaw (1, left forearm) – 50

* Mini-Torpedo Launcher – 80

* Shoulder Mini-Missile Launchers (2; one in each) – 25 each

Head/Driver's Compartment (exterior) – 150

* Reinforced Pilot Compartment – 100

** Main Body – 540

* A single asterisk indicates a small and/or difficult target to strike, requiring the attacker to make a "Called Shot," but even then the attacker is -4 to strike.

** Depleting the M.D.C. of the main body shuts the vehicle down completely, making it useless.

Speed:

Running: 60 mph (96 km) maximum.

Leaping: 10 feet (3 m) high or across, increase 50% with a running start.

Water: Up to 30 mph (48 km) on the surface via propulsion system, limited to about 20 mph (32 km) submerged and 20 mph (32 km) walking along the lake floor. Maximum depth is 4,000 feet (1,219 m).

Flying: Not applicable.

Statistical Data:

Height: 26 feet (8 m).

Width: 16 feet (4.8 m), from shoulder to shoulder.

Length: 15 feet (4.6 m).

Weight: 25 tons.

Robot Strength: P.S. 40.

Cargo: The Beachmaster has a small locker next to the pilot's seat that holds survival equipment and personal weapons, large enough for a rifle and survival kit and not much more. In addition, there is a cargo pod on the robot's back that holds an inflatable life raft and can accommodate up to 150 lbs (68 kg) of additional items.

Power System: Nuclear; average energy life is 20 years. Solid Oxide Fuel Cell and electric battery versions are also available.

Cost: 28 million credits nuclear, 23 million Solid Oxide, 20 million electric battery.

Weapon Systems:

1. Blue-Green Chest Lasers (2): A pair of chest-mounted blue-green lasers are the Beachmaster's only energy weapons.

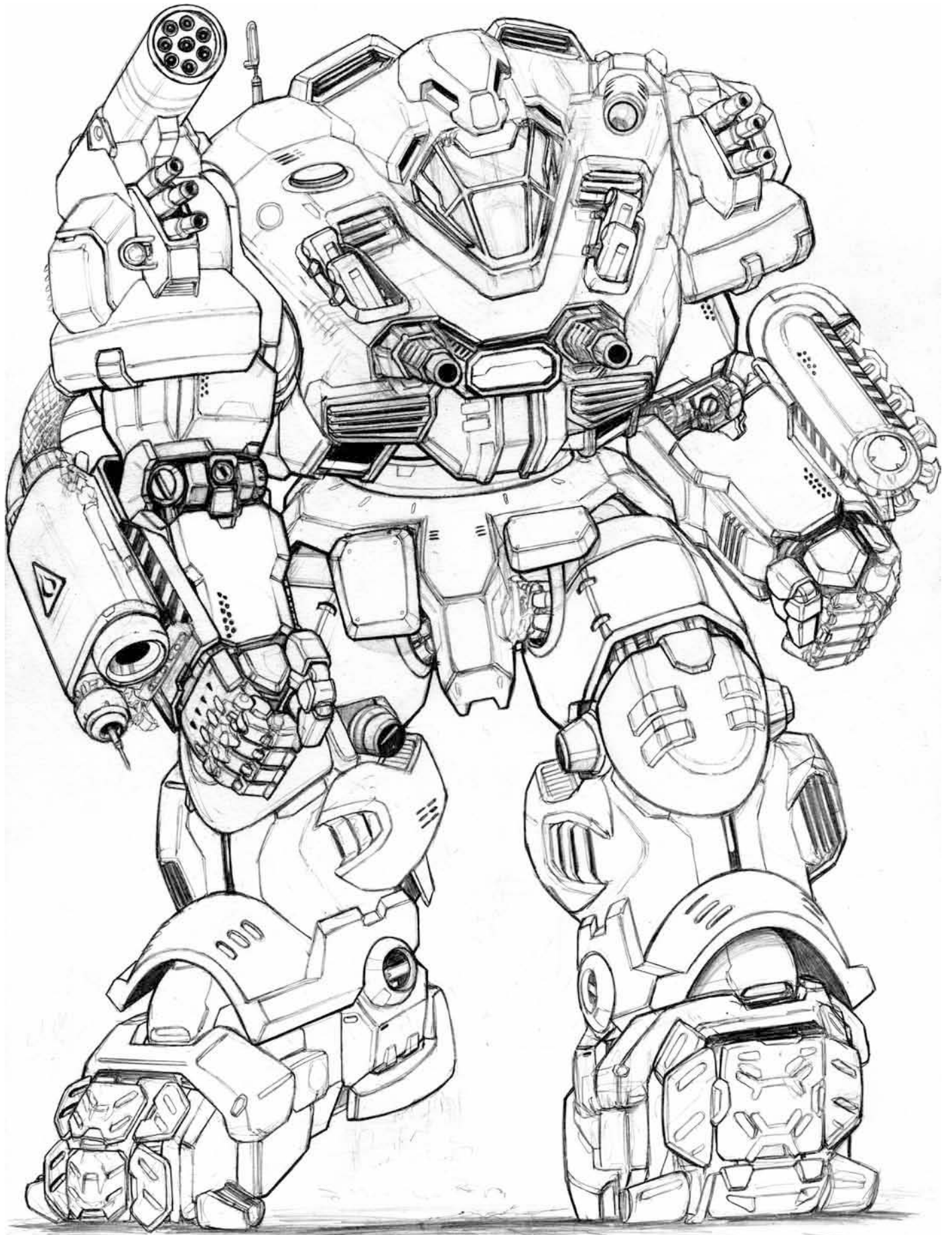

E. WALTON

They have respectable range underwater and are even more effective on land.

Primary Purpose: Anti-Personnel.

Secondary Purpose: Defense.

Range: Underwater: 1,200 feet (366). On land: 2,000 feet (610 m).

Mega-Damage: 4D6 M.D. per blast, 1D4x10+4 per simultaneous dual blast at the same target.

Rate of Fire: Each single or dual blast counts as one melee attack.

Payload: Effectively unlimited.

2. **Shoulder Mounted Mini-Torpedo Launcher (1):**

Mounted over the right shoulder is a mini-torpedo launcher on a turret that can turn 360 degrees and has a 90 degree up and down arc of fire. It can launch torpedoes when submerged, moving along the surface of the water or standing adjacent or above the water's surface (torpedoes drop into the water and speed toward the target).

Primary Purpose: Anti-Armor.

Secondary Purpose: Anti-Ship.

Range: About one mile (1.6 km).

Mega-Damage: Varies by missile/torpedo type, but usually armor piercing (1D4x10 M.D.) or plasma (1D6x10 M.D.), or a combination of the two.

Rate of Fire: One at a time or in volleys of two, four or eight.

Payload: 16 mini-torpedoes.

3. **Shoulder Mounted Mini-Missile Launchers (2):**

Built into each shoulder is a small mini-missile launcher with three missiles each.

Primary Purpose: Anti-Armor.

Secondary Purpose: Anti-Ship.

Range: One mile (1.6 km), one third that distance when fired underwater and -3 to strike targets underwater or on the surface of water when fired from a submerged position under the waves.

Mega-Damage: Varies by missile/torpedo type. Plasma (1D6x10 M.D.) is standard.

Rate of Fire: One at a time or in volleys of two, four or six.

Payload: Six total, three mini-missiles in each shoulder.

4. **Heavy Flamethrower:**

The robot's right arm mounts a heavy flamethrower that is normally used to flush out bunkers and enemy positions, but is also very effective against sea monsters and most animals afraid of fire. The flamethrower is designed to be waterproof and is usable on the surface of the water, but comes with valves that automatically seal it off underwater, deactivating it and preventing water from contaminating the napalm reserve.

Primary Purpose: Anti-Structure.

Secondary Purpose: Anti-Personnel.

Range: 400 feet (122 m).

Mega-Damage: 1D4x10 M.D. to the target and anyone within 10 feet (3 m). Those caught within reach of the flamethrower's attack inside small, enclosed areas like bunkers, caves or non-sealed vehicles and without environmental gear or oxygen, must roll to save vs poison (smoke inhalation and lack of air) or be rendered unconscious for 1D4 melee rounds.

Rate of Fire: Each burst counts as one melee action/attack.

Payload: Approximately 48 bursts. The flamethrower can be refueled with military-grade napalm or use normal diesel or gasoline (reduces damage to 5D6 M.D.). 80 gallon (302 liter) fuel reserve.

5. **M.D. Chainsaw (1, left forearm):**

The chainsaw can be locked in position on the forearm in its stowed position (as de-

picted) to slice opponents or to cut through ship hulls, netting, barbed wire, etc., via the side of the arm (great for backhand strikes, too). Or the chainsaw can be slid forward to extend above and beyond the hand and used like a short sword to slice through obstacles and opponents alike. The blades are capable of cutting through Mega-Damage armor and inflicting grievous wounds to many monstrous opponents.

Primary Purpose: Boarding Ships, Anti-Fortification and Sabotage.

Secondary Purpose: Melee Combat and Anti-Personnel.

Range: Melee combat.

Mega-Damage: The chainsaw does 5D6 M.D. per attack, and even when turned off, it does 1D4 M.D. plus robot P.S. punch damage for slashing attacks. **Note:** The chainsaw is a modular unit that can be easily replaced with a chainsaw that has *silver saw-teeth* to battle supernatural beings vulnerable to silver. The problem is that the silver plating is destroyed after 2D4 uses against M.D.C. armor, so it is best to swap out the chainsaw unit on an as needed basis depending on the anticipated opposition.

Payload: Effectively unlimited.

6. **Electric Field Antenna:**

The final trick up the Beachmaster's sleeve is a long, thin antenna mounted along the robot's back. When activated, the antenna produces a strong electric field in the water around the robot, repelling sharks and other sea creatures and dissuading sea monsters from attacking. The field does no real damage, but has a stunning effect which prevents sensitive creatures from closing in on the robot and will drive less determined attackers away. The field has no effect on torpedoes, ships, submarines or other watercraft. Roll on the following table for each activation of the antenna (counts as one melee action/attack). **Note:** +10% for normal sharks, fish and sea creatures. -10% for dolphins, whales, large sea monsters and Mega-Damage animals. -25% for really massive sea monsters. Only works in water.

01-20% No Effect: The creature is either immune to the electric charge or the field has been dissipated or weakened by sudden temperature or salinity changes in the water.

21-40% Mild Effects: The field reduces the target's attacks by 1 for this melee round and causes it to lose initiative.

41-60% Surprised: The target loses 2 attacks this melee round and loses initiative.

61-80% Stunned: The target loses all attacks this melee round and is -6 on initiative for the next melee round.

81-100% Temporary Paralysis: The target is unable to attack or even move for 1D4 melee rounds.

7. **NG-505 Heavy Rail Cannon (Optional):**

The Beachmaster "Ship Hunter" variant has a Heavy Rail Cannon mounted in place of the mini-torpedo launcher. The rail cannon cannot be used underwater, however, leaving the Beachmaster with only its blue-green lasers to defend it while submerged.

Primary Purpose: Anti-Ship/Anti-Sea Monster.

Secondary Purpose: Anti-Armor.

Range: 4,000 feet (1,220 m).

Mega-Damage: 2D4x10 M.D.

Rate of Fire: Each shot counts as one melee attack.

Payload: 90 round drum.

8. **Hand to Hand Combat:**

Rather than use a weapon the pilot can engage in Mega-Damage hand to hand combat as per Robot P.S. 40. See *Heavy Ground Robot Training* on page

352 of **Rifts® Ultimate Edition** for the number of attacks and bonuses.

9. Sensor System Note: Sonar as well as radar, and telescopic, passive nightvision and polarizing lens in addition to all other features common to NG robots.

EX-5 Behemoth Explorer

The massive Behemoth Explorer is one of Northern Gun's oldest and most famous designs. Only the Hunter Mobile Gun and Samson power armor are more iconic. It is an unusual robot vehicle in that it is a science laboratory and house trailer on legs. Typically, the Behemoth Explorer will have its quarters divided into four separate sections:

1. Ten separate living quarters. Each room can accommodate 2-4 people sleeping in bunk-bed style cots that fold down from the wall. That's 20-40 people comfortably, 50-60 cramped with people sleeping on the floor or in other rooms. There are also two small lavatories and the entire robot can be heated and air-conditioned.

2. A communal dining area and observation deck; the glass enclosure on top of the main body. The Mega-Damage plexiglass has 20 M.D.C. per 12 foot (3.6) diameter.

3. A storage bay that can hold four small vehicles like hovercycles and a half dozen suits of power armor with room to spare. The pilot and crew compartment is located in the center protrusion on the nose of the robot, between the two huge searchlights. Four smaller spotlight turrets are located on the side of the robot in the front and toward the rear. Two small spotlights are also located on either side of the arms.

4. A small med-laboratory with basic equipment and tools such as computers, microscopes, spectrometer, x-ray machine, EKG, EEG, gear for chemical analysis, containers for storing specimens, an examination table, a couple of lab tables, drawers, shelves, an isolation chamber, a small room with two beds that fold down from the wall, etc. The end result is a decent med-lab that functions as a sick bay and laboratory.

The robot arms are designed for wilderness exploration and investigation, and well suited for grasping. A pair of smaller retractable arms and mechanical hands are also housed in the big forearms. The robot was originally designed for expeditions sponsored by wealthy kingdoms and city states, but it has also been adopted by independent teams of adventurers and explorers, especially those going on long expeditions to explore the wilderness. To NG's surprise, the Behemoth Explorer has also become popular among mercenary companies, who can use the giant robot as a mobile barracks or base of operations, as well as merchants, rebels, bandits and refugees. Ultimately, the Behemoth is ideal for anyone who can afford it and who plans to be out in the wilderness or embarking on a long trip through the wilderness. Northern Gun, MercTown and a few other places have even started to rent the use of the Behemoth Explorer. Renting the robot requires a 5-10 million dollar security deposit and a fully planned itinerary. Failure to return it puts the LPO (Loss Prevention Office) on the case.

Weapon systems are minimal. The Behemoth has only a concealed mini-missile launcher on the side of each arm as a means of protection. Sometimes, 2-6 rail guns or other weapon turrets are added by energetic organizations, but too many weap-

ons are a waste of time and resources as the Behemoth Explorer is not suited for combat at all! Besides, over the years, this big robot has become recognized by most as non-hostile and housing non-combatants such as explorers, scientists, medical teams, scholars and refugees, and as such, most mercenaries and even bandits and raiders leave them alone. Even Simvan Monster Riders and Xiticix usually let the Behemoth Explorers travel through their lands without incident. However, if weapon systems are mounted on the exterior, the Behemoth Explorer becomes a potential dangerous invader to be eradicated. Not a good thing.

The lead designers, **Jeff Farrar**, **James Dombrowski** and **Sam Beedah**, believed the Behemoth filled an important niche, but never expected the robot to be a big seller. And in a way, it is not a huge seller, but there has always been enough demand (much more than anticipated) to keep making the old favorite every year for the past 22 years. Moreover, its popularity has inspired a new generation of "exploration robots," including the *Bulldog*, *Okemos* and *Behemoth Super-Explorer*.

Model Type: EX-5 Explorer.

Class: Behemoth Class Mobile Medical and Research Robot Vehicle.

Crew: Three; one pilot, one copilot, one communications officer.

Passengers: 20 to 40 passengers.

M.D.C. by Location:

Upper Arms/Shoulders (2) – 120 each

Forearms (2) – 200 each

Hands (2 large) – 60 each

* Hands (2 small, retractable) – 30 each

Legs (2) – 250 each

* Main Searchlight (1, lower front, large) – 15

* Side & Arm Searchlights (6) – 5 each

Top-Mounted Searchlights (2, front) – 10 each

Pilot Compartment – 200

Observation Deck (top) – 300

** Sensor Arrays (2, rear) – 30 each

*** Main Body – 500

* A single asterisk indicates a small and/or difficult target to strike, requiring the attacker to make a "Called Shot," but even then the attacker is -3 to strike.

** Destroying one sensor housing has no significant impact on sensor readings. Knock them both out and radar and sensor systems are gone. The pilot and crew must now rely on their own human vision and any portable optics or sensor systems they might have on board. The sensor turrets are small and difficult targets to strike and can only be hit when a character

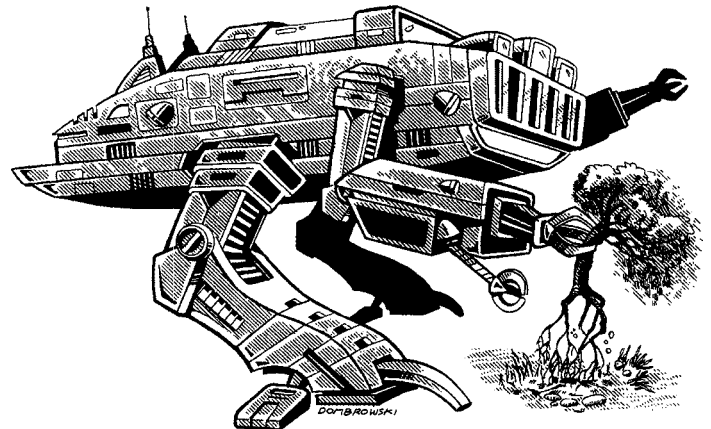

makes a “Called Shot,” and even then the attacker is -3 to strike and needs to be in just the right position.

*** Depleting the M.D.C. of the main body shuts the robot down completely, rendering it useless.

Speed:

Running: 40 mph (64 km) maximum. Leaping is not possible.

Leaping: 10 feet (3 m) high and lengthwise, but counts as two melee actions and makes a profound thump or crashing sound.

Water: Cannot swim, but can walk along the lake floor at 12 mph (19.2 km). Maximum depth is 1,100 feet (335 m).

Flying: Not possible.

Statistical Data:

Height: 60 feet (18.2 m).

Width: 20 feet (6.1 m).

Length: 82 feet (25 m).

Weight: 25 tons fully loaded, but with empty cargo bay.

Physical Strength: Robotic P.S. of 40.

Cargo: 15x40x12 foot (4.6 x 12.2 x 3.6 m) storage area. 200 ton limit.

Power System: Nuclear; average energy life is 12 years.

Cost: Originally sold for 100 million credits new, but the price has dropped to 85 million in recent years. 40-60 million for a used, rebuilt robot with its full sensors and features and missing only 3D6% of its original M.D.C. A used and battered vehicle with half the normal M.D.C. and sensory systems costs 20-30 million. Fair availability for all. Not available with electric batteries.

Weapon Systems:

1. Mini-Missile Forearm Launchers (2): Mounted on the side of each arm is a missile launcher.

Primary Purpose: Defense.

Secondary Purpose: Anti-Monster and Anti-Missile.

Range: One mile (1.6 km).

Mega-Damage: Any type of mini-missile can be used, but standard issue is fragmentation (5D6 M.D.) and plasma (1D6x10 M.D.).

Rate of Fire: One at a time or in volleys of 2, 3 or 4. Firing a single mini-missile or a volley of 2-4 counts as one melee attack.

Payload: 48 total, 24 in each arm. Hundreds can be stored inside the robot.

2. Hand to Hand Combat: Rather than use a weapon, the pilot can engage in Mega-Damage hand to hand combat. However, the Behemoth Explorer is not designed for combat, so it gets half the number of attacks and reduce the bonuses described for *Heavy Ground Robot Training*, on page 352 of **Rifts® Ultimate Edition**, also by half. Robot P.S. 38 for the large arms and hands, P.S. 21 for the small ones.

Large Arms – 3D6 M.D. for a full strength punch and tear or pry. 2D6 M.D. crush. Power Punch does 5D6+3 M.D.

Retractable Arms – 1D4 M.D. punch and tear. Power Punch not possible.

Stomp or Trample – 2D6 M.D.

Stomp – 2D6 M.D.

Body Block – 2D6 M.D. with a 01-70% chance of knocking down opponents of equal size or smaller. Victims of knockdown lose initiative and one melee attack.

3. Sensor System Note: The Behemoth has some of the best sensory equipment available in a robot vehicle. All standard robot features plus the following:

A. Thermal-Imager: A special optical heat sensor that allows the infrared radiation of warm objects to be converted into a visible image. Enables the pilot to see in the dark, in shadows, and through smoke. **Range:** 2,000 feet (610 m).

B. Infrared and Ultraviolet Optics: This optical system projects a beam of infrared light that is invisible to the normal eye. The infrared beam enables the pilot to see in the dark and to see other infrared beams. The ultraviolet system enables the pilot to see into the ultraviolet spectrum of light and is mostly used to detect the light beams of ultraviolet detection systems. **Note:** The infrared light beam can be seen by anybody who also has infrared optics, and the beam can be traced back to its source. Smoke impairs the infrared beam, making it impossible to see.

C. Infrared Searchlights: The two front headlights can also serve as infrared searchlights. The lights can be used to scan an area at night using the invisible light to avoid detection. Only somebody who can also see infrared light will see the beam. **Range:** 500 feet (152 m).

D. Enhanced Radar: Can identify and simultaneously track up to 96 different targets. **Range:** 100 miles (160 km).

E. Multi-Camera System (4): The cameras have telescopic lenses as well as macro-lenses for close work. **Range:** 4,000 feet (1,219 m).

EX-9 Behemoth Super-Explorer

If you didn't think anything could get bigger than the Behemoth Explorer, guess again. The Behemoth Super-Explorer, the brainchild of NG design wizards **Dennis Kelley, Cory Sommer** and **Ryan Thomsen**, has just been made available by NG on the open market. It is a modernized, larger version of the Behemoth Explorer, and people are going wild over it.

The Super Explorer is very much a well thought out improvement on the Behemoth. Also known as the “Super-X” – the Behemoth Super-Explorer, though bigger, improved and more heavily armed – is very much intended to be an exploration vehicle, not a war machine. With so many people being displaced by war and disasters, the Super-X was made to have a larger and better equipped medical bay, more than one laboratory, and increased housing for more people. It also has many other unique features to make travel and exploration in the wild safer, more comfortable, and some would say, downright homey.

Like its predecessor, the massive robot vehicle is intended for wilderness travel and exploration. The four legs, instead of two, provide superior stability, but the robot can limp along on two legs (at one third its normal speed) if necessary. It also has more sensors and medical and laboratory space, and additional defensive weapons. There was some concern about giving the Super-X more weapons, but it was deemed wise for travel in hostile wilderness. The EX-9 Behemoth Super-Explorer remains recognized as a non-combat exploration vehicle, and should still enjoy the rights of passage the older EX-5 Behemoth Explorer has been given. This is helped by the preservation of many familiar EX-5 characteristics, making it immediately recognized as a scientific or civilian transport, not a combat robot.

While mercenaries and hostile forces could tear out the laboratories and add weapons to turn the Super-X into an armored personnel carrier and weapon platform, it really lacks the armor, speed and combat capabilities to be effective in combat. It is so big and slow that it makes an easy target to blast to smithereens, and its arms are not designed for fighting.

Super-X Features of Note

Rooftop Level

1. Sensors. Starting at the top, there are two redundant sensor arrays with radar and sonar capabilities as well as a battery of other sensors and long-range, wideband, directional communications. Both arrays are identical and located outside the enclosed Observation Deck in the back of the vehicle. Each has 100 M.D.C.

2. Observation Deck. The top level is the Observation Deck and community area. It is enclosed by Mega-Damage plexiglass eight inches thick (20.3 cm), but also has sliding, exterior M.D.C. metal shutters to close off the windows should the Super-Explorer fall under attack (30 M.D.C. per 12 foot/3.6 m section). On the inside there are stairs that lead to catwalks to look out the window, though the view is a bit opaque due to the thickness of the glass. Still, sunlight fills the deck, which makes doing anything in this part of the Super-X feel very unlike being inside a robot. For one thing, you can have live plants growing inside the vehicle.

This cavernous space is divided into the following sections:

- Kitchen – can cook enough food to feed as many as 120.
- Cafeteria-style dining area that can seat 60 at a time.
- Lounge area.
- Small meeting room.
- A library/computer room.
- Small laboratory.
- Small greenhouse for botanical specimens and studies.
- Storage room about the size of a bedroom.

3. Forward Observation Deck. Located above and behind the “head” of the robot is the forward observation deck. It is an M.D.C. enclosed chamber with four inch (10 cm) plexiglass and seating for six; standing room for 12-16. This chamber is separate from the rest of the Observation Deck, and it can be sealed off, airtight, with a locking environmental hatch (120 M.D.C.), should the deck become compromised. The deck has 130 M.D.C.

4. Rooftop Hangar Bays One and Two. On both sides of the Forward Observation Deck are airlock-style hatches large enough to hold a half dozen people clad in power armor suits or six rocket bikes or hovercycles for quick exit (or reentry) from the top deck. This may also used for medivacing injured people to the laboratory or sick bay. Each has 200 M.D.C.

Second Level of the Super-Explorer

The second level inside the robot is divided into the following sections: Note that except for the storage bay, the robot can be heated and air-conditioned throughout.

- **Main Laboratory** with basic equipment and tools such as computers, microscopes, spectrometer for chemical analysis, containers for storing specimens, an examination/autopsy table, a couple of lab tables, four desks, shelves, an isolation chamber, quarantine room, and other equipment for a lab. The door can be locked, and has 30 M.D.C.

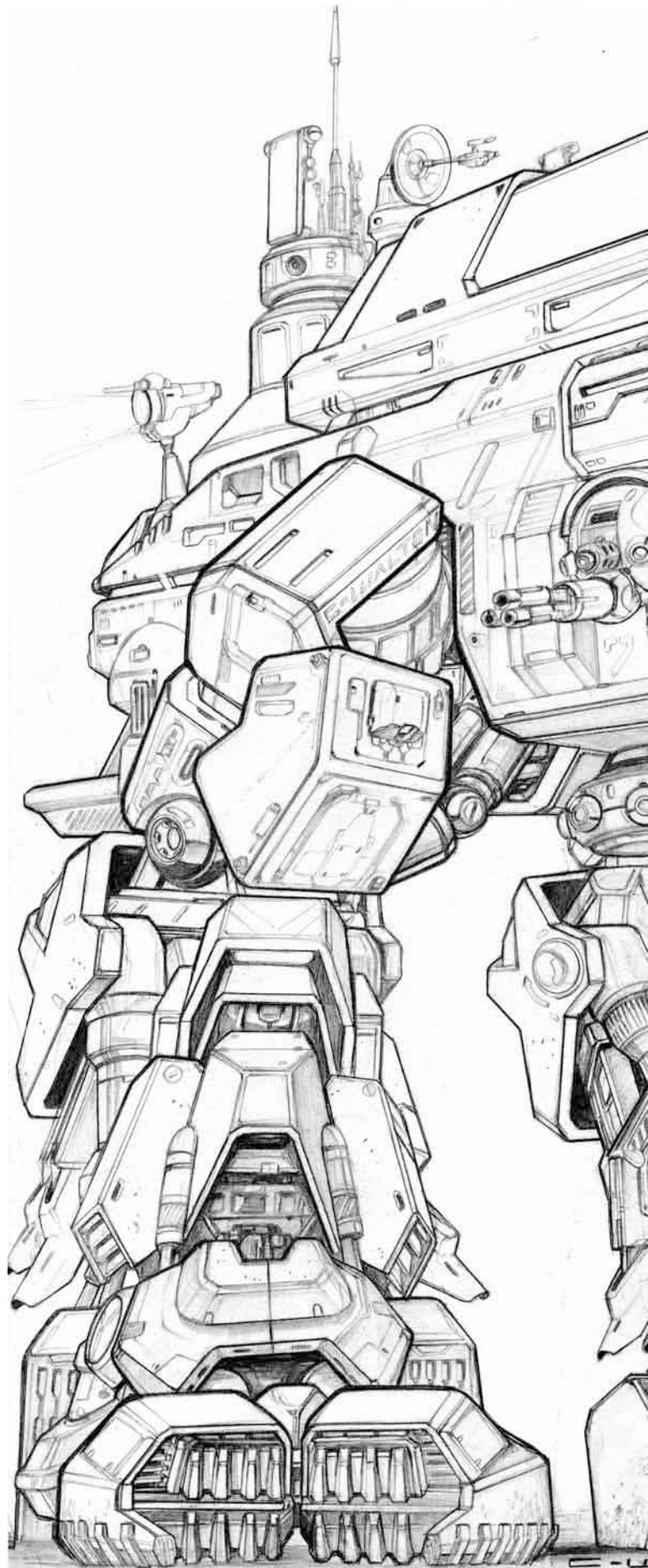



- **Medical Bay.** One main examination room, two very small examination rooms, one sick room with four beds that fold down from the wall for the seriously ill, and a small doctor's lab comprise the med-bay. There is medical equipment and capabilities roughly equal to a small clinic, including x-ray machine, EKG, EEG, and so on. Advanced med systems such as a half dozen of each of the following: Bio-Comp Monitors, Compu-Drug Dispensers, IRMSS (Internal Robot Medical Surgeon Systems), IRVT (Internal Robot Visual Transmitters), RAU (Robot Antiseptic Units), RMK (Robot Medical Kits), RSU (Sedative Units), Palm Bio-Units, Micro Scales, at least two Portable Bio-Scan and Bio-Labs, one Portable Laboratory, one Portable Scan Dihilator, two portable language translators, and a pair of Multi-Optics Helmets are all standard equipment that come stocked in the med-lab of the Behemoth Super-Explorer. The door can be locked, and has 30 M.D.C.
- **Two Barracks-Style, Living Quarters.** Three level bunks are built into the floors, each with its own private locker, plus communal lavatory and shower. Sleeping berths and lockers for 30 people per barracks. The door and a 12 foot (3.6 m) diameter of wall has 20 M.D.C.; this is true of most interior walls and doors unless stated otherwise.
- **Two Crew Quarters.** Two rooms with two beds and modest living area (two desks, two small closets and dressers, and a sofa) and private bathroom. The door and a 12 foot (3.6 m) diameter of wall has 20 M.D.C.
- **Pilot's Quarters.** A small room much like the crew's quarters with a private bathroom. The door and a 12 foot (3.6 m) diameter of wall has 20 M.D.C.
- **Auxiliary Bridge Control.** A secured room. The airtight hatch has 120 M.D.C. and a 12 foot (3.6 m) diameter of wall has 100 M.D.C.
- **Storage areas.** There are two nice-sized storage areas. The door and a 12 foot (3.6 m) diameter of wall has 20 M.D.C.

Other notable Robot Features

Belly Cargo Bay. A cargo storage bay in the belly of the Behemoth Super-Explorer can hold 20 tons of cargo, and 6-8 small vehicles like hovercycles (or one or two medium-sized vehicles) and 12-20 suits of power armor (more depending on how much other cargo there is, and how it is organized). The storage bay can be loaded and accessed by a cargo platform that lowers down like an elevator from the cargo bay. Elevator platform has 75 M.D.C.

Pilot's Deck/The Bridge. This is the large, head-like compartment at the front of the Behemoth Super-Explorer. It seats the pilot and has stations for the core crew, but there is seating for an additional eight passengers; standing room for 12-16. It is designed very much like the Forward Observation Deck with four inch (10 cm) M.D.C. plexiglass. It has 300 M.D.C.

In case of an emergency, the Pilot's Deck can be shut down, disengaged and the deck sealed off, airtight with a locking environmental hatch (120 M.D.C.). This occurs when the Pilot's Deck is breached or destroyed. An **Auxiliary Bridge Control** room is located on the second level of the robot, which can be piloted via cameras and sensors. This secured room also controls communications, life support, cooling and heating. The airtight hatch has 120 M.D.C. and a 12 foot (3.6 m) diameter of wall has 100 M.D.C.

Exterior Lighting, Headlights and Spotlights. Two light towers are located on the front of the robot, and two, slightly

larger light towers are mounted in the rear. All can rotate 360 degrees and can tilt up or down 45 degrees. Range is 1,000 feet (305 m). Each has 25 M.D.C.

Light domes are located on the right and left undercarriage of the Super-Explorer. The two protrusions which could be mistaken for snub-nosed gun barrels are laser distancers that can measure the distance of a location, vehicle, fellow traveler or animal up to one mile (1.6 m) away. The laser distancers can rotate 360 degrees and have a 30 degree downward arc. A light dome illuminates a 200 foot (61 m) radius. Each has 5 M.D.C.

Belly Light & Camera Turret. Located on the underbelly, toward the middle, and right behind the Cargo Bay elevator hatch (which has 100 M.D.C.), is an odd looking turret. The eight protrusions around it are all spotlights with built-in cameras. Four are incandescent lights and four are infrared. Each can rotate 45 degrees to position its light or film; the turret can store up to 5,000 hours of digital footage. The turret itself has 100 M.D.C. and can rotate 360 degrees. The optics system is designed to provide a clear view in all directions of what is happening on the ground underneath and around the Behemoth Super-Explorer. The infrared lights and night cameras are for night security and to record the behavior of wildlife. Each member of the core crew gets a live feed from each active camera at his control console at all times, and he can also store and review past footage. Such footage can also be sent to the lab, the cafeteria, and other locations for display.

Headlights: A pair of headlights are located on top of the Pilot's Deck. The battery of shapes on the side of the robot are also forward-facing lights that can be repositioned and pointed individually up to 30 degrees in any direction.

Each of the large arms also has a headlight and camera that faces forward the same direction as the arm.

The nose gun also has a small incandescent and infrared light and gun camera.

Running lights and other small to tiny lights, reminiscent of aircraft lights, are located around the hatches, arms and legs of the robot.

Robot utility arms & hands. The hands are more articulated than the old EX-5 Behemoth Explorer, though like it, they are used for rooting through ruins, searching for salvage, grasping and retrieving specimens of flora, examining dead animal carcasses, and so on, without ever leaving the robot.

A pair of smaller retractable arms and mechanical hands are housed in the big forearms, and have a more delicate touch. The hands in the small arms can extend an additional seven feet (2.1 m) and contain a light, a camera, a plasma torch and a laser cutter (the latter two both have a maximum range of four feet/1.2 m and damage settings of 5D6 S.D.C., 1D6x10 S.D.C., 1 M.D., 1D4 M.D. and 2D4 M.D.; used for repairs, excavation and salvage operations). Both pairs of hands can be used for picking up and moving debris, picking up fallen trees, moving cargo, construction work, repairing other robots and vehicles, retrieving salvage, shooing away animals and even pushing away large, hostile creatures. Robot P.S.: 40 for the large hands, 30 for the small ones.

Weapon systems are improved. The Behemoth Super-Explorer has three obvious weapon turrets: The nose rail gun and a laser turret on each side. These are intended for defense, but make decent assault weapons, too.

Not so obvious are the concealed missile launchers located in the top section of the front legs. Mini-missiles (and lots of them!)

are the standard armament, but for an extra half million or one million credits, they can be replaced with short-range (16 per leg) or medium-range missiles (8 per leg).

There is some concern that these weapon systems may bring more heat on the Behemoth Super-Explorer, but this is a dangerous world with a need for basic protection. Most people still recognize the Super-Explorer as a mostly benign vehicle probably housing non-combatants such as explorers, scientists, medical teams, scholars and refugees, and leave it alone. And that is the intention of the designers: To keep it as a non-combat vehicle, but one that has a bit more protection than its smaller, previous version.

Model Type: **Model Type:** EX-9 Super-Explorer.

Class: Behemoth Class Mobile Medical & Research Robot Vehicle.

Nickname: Super-X.

Core Crew: Four; one pilot, one copilot, one communications officer and a dedicated gunner. The Super can be run by the skeleton crew listed above and driven by just one pilot, if necessary.

Passengers/Research Team: 40 passengers.

M.D.C. by Location:

- * Headlights & Small Lights (several) – 5 each
- * Dome Lights (2, front) – 10 each
- * Light Towers (4, two front, two back) – 25 each
- * Belly Light Turret (1, underbelly, center) – 35 for the unit; 4 M.D.C. per individual light & camera.
- ** Sensor Arrays (2, rear, top) – 100 each
- Observation Deck (1, top) – 300
- Forward Observation Deck (1, front) – 130
- Rooftop Hangar Bays (2, front, top) – 200 each
- Upper Arms, Large (2) – 225
- Forearms, Large (2) – 200 each
- Hands, Large (2) – 120 each
- Arm Housing, Small (2) – 125 each
- Hands, Small (2) – 55 each
- Legs & Feet (4) – 350 each
- Rail Gun Turret (1, nose) – 170
- Laser Turrets (2, one per side) – 150 each
- Concealed Missile Launcher (2, upper leg) – 100 each
- Reinforced Pilot Compartment – None, see Auxiliary Controls.
- Pilot's Deck/Bridge (1, front, center) – 300
- *** Main Body – 700

* A single asterisk indicates a small and/or difficult target to strike, requiring the attacker to make a "Called Shot," but even then the attacker is -3 to strike.

** Destroying one sensor housing has no significant impact on sensor readings. Knock them both out and radar and sensor systems are gone. The pilot and crew must now rely on their own human vision and any portable optics or sensor systems they might have on board. The sensor turrets are small and difficult targets to strike and can only be hit when a character makes a "Called Shot," and even then the attacker is -3 to strike and needs to be in just the right position.

*** Depleting the M.D.C. of the main body shuts the robot down completely, rendering it useless.

Speed:

Running: 45 mph (72 km) maximum.

Leaping: Not possible.

Water: Cannot swim, but can walk along the lake floor at 12 mph (19.2 km). Maximum depth is 1,500 feet (457 m).

Flying: Not possible.

Statistical Data:

Height: 70 feet (21.3 m).

Width: 40 feet (12.2 m).

Length: 110 feet (33.5 m).

Weight: 35 tons fully loaded, but with empty cargo bay.

Physical Strength: Robotic P.S. of 40.

Cargo: 30x40x20 foot (9.1 x 12 x 6.1 m) storage area. 250 ton limit.

Power System: Nuclear; average energy life is 12 years.

Black Market Cost: 142 million credits new. It's so new there are no "used" Super-X on the market. Fair availability.

Weapon Systems:

1. NG-X009 Rail Gun Turret (1): The main gun for the defense and protection of the Behemoth Super-Explorer is a rail gun turret built into the nose, under the Pilot's Deck/Bridge. It can rotate 180 degrees to the right and left and has a 45 degree of up and down arc of fire. This weapon can be operated by the pilot or copilot. The rail gun has superior range and fires hard shells that cannot be mitigated by energy-reflecting armor or magic. Moreover, special "monster fighting" ammunition (see the Gunwolf) can be substituted as needed.

Primary Purpose: Anti-Armor.

Secondary Purpose: Anti-Aircraft/Flyers.

Range: 4,000 feet (1,219 m).

Mega-Damage: A burst is 40 rounds and inflicts 1D4x10 M.D.

Rate of Fire: Each burst counts as one melee attack/action.

Payload: 8,000 rounds for a total of 200 bursts, loaded into two, oversized, detachable drum magazines (accessed from the inside).

2. NG-437-TBL Triple Barrel Laser Turret (2, side): The 437-TBL is a triple barrel laser turret with gun camera and laser targeting. The laser cannon turret can rotate 90 degrees and has a 90 degree up and down arc of fire; typically has a dedicated gunner, but can be fired by the copilot or communications officer if necessary.

Primary Purpose: Defense and Anti-Aircraft/Flyers.

Secondary Purpose: Anti-Monster and Anti-Personnel/Bandits.

Range: 2,000 feet (610 m).

Mega-Damage: One laser blast does 3D6 M.D., two 6D6 M.D. or a simultaneous triple blast does 1D6x10+3 M.D. (most of the blasts hit), but counts as TWO melee attacks.

3. Concealed Missile Launcher (4): Concealed in the top of each front leg are a pair of missile launchers. The launch doors open to fire and immediately close after launching. May be launched by the gunner, the pilot or the copilot.

Primary Purpose: Defense and Anti-Monster.

Secondary Purpose: Anti-Armor.

Range: Varies with type.

Mega-Damage: Varies with type.

Standard Launcher and Payload is mini-missiles. Any type of mini-missile can be used, but standard issue is a mix of 60% High Explosive (1D4x10 M.D.), 30% plasma (1D6x10 M.D.) and 10% smoke.

Note: For an extra 500,000 credits, the mini-missile launchers can be *replaced* with short-range missile launchers, and for one

million credits they can be replaced with medium-range missile launchers. Most people stick with the mini-missiles.

Rate of Fire: One at a time or in volleys of two or four. Firing a single mini-missile or a volley counts as one melee attack.

Payload: Varies with the type of missile. **Mini-Missiles:** 128 total, with 32 mini-missiles per launcher. **Short-Range Missiles:** 32 total with 8 short-range missiles per launcher. **Medium-Range Missiles:** 16 total, with four medium-range missiles per launcher.

4. Hand to Hand Combat: Rather than use a weapon, the pilot can engage in Mega-Damage hand to hand combat. However, the Behemoth Super-Explorer is not designed for combat, so it gets half the number of attacks and reduce the bonuses described for *Heavy Ground Robot Training* on page 352 of **Rifts® Ultimate Edition**, also by half. Robot P.S. 40 for the large arms, Robot P.S. 30 for the small ones.

Large Arms – 4D6 M.D. for a full strength punch and tear or pry. 2D6 M.D. crush. Power Punch does 6D6+6 M.D. The large arms can extend an additional seven feet (2.1 m) and contain a spotlight, a camera, a plasma torch and a laser cutter. The cutting tools have a maximum range of four feet (1.2 m) and damage settings of 5D6 S.D.C., 1D6x10 S.D.C., 1 M.D., 1D4 M.D. and 2D4 M.D.; used for repairs, excavation and salvage operations.

Small, Retractable Arms – 1D6 M.D. punch and tear. Power Punch does 2D6 M.D. The small arms can extend an additional seven feet (2.1 m) and contain a light, a camera, a plasma torch and a laser cutter. The cutting tools have a maximum range of four feet (1.2 m) and the same damage settings as the large arms.

Other Close Combat Attacks:

Stomp or Trample – 2D6+4 M.D.

Body Block – 3D6 M.D. with a 01-80% likelihood of knocking down opponents of equal size or smaller. Victims of knockdown lose initiative and one melee attack.

5. Sensor System Note: The Behemoth has some of the best sensory equipment available in a robot vehicle. All standard robot features plus the following:

A. Thermal-Imager: A special optical heat sensor that allows the infrared radiation of warm objects to be converted into a visible image. Enables the pilot to see in the dark, in shadows, and through smoke. **Range:** 2,000 feet (610 m).

B. Infrared and Ultraviolet Optics: This optical system projects a beam of infrared light that is invisible to the normal eye. The infrared beam enables the pilot to see in the dark and to see other infrared beams. The ultraviolet system enables the pilot to see into the ultraviolet spectrum of light and is mostly used to detect the light beams of ultraviolet detection systems. **Note:** The infrared light beam can be seen by anybody who also has infrared optics, and the beam can be traced back to its source. Smoke impairs the infrared beam, making it impossible to see.

C. Infrared Searchlights: The two front headlights also serve as infrared searchlights. The lights can be used to scan an area at night using the invisible light to avoid detection. Only somebody who can also see infrared light will see the beam. **Range:** 500 feet (152 m).

D. Enhanced Radar: Can identify and simultaneously track up to 96 different targets. **Range:** 100 miles (160 km).

E. Enhanced Sonar: Can identify and simultaneously track up to 96 different targets for underwater operation. **Range:** 50 miles (80 km). Same IFF and relay capabilities as radar.

F. Built-in Language Translator: Programmed with the nine known languages of the Americas and can hold 12 additional languages. It can recognize and monitor up to three different voices and two different languages or dialects. Level of accuracy is 98.7%, with a three second delay when directed at one individual, but drops to 78% with a six second delay when translating three speakers simultaneously.

G. Nightvision Optics: Passive light amplification that allows the pilot, gunner and communications officer to see in the dark as long as there is at least some ambient light. 2,000 foot (610 m) range, but is completely useless in total darkness.

H. Multi-Camera System (many): The cameras have telescopic lenses as well as macro-lenses for close studies, and time lapse capabilities. Telescopic Range: 2 miles (3.2 km).

I. Communications and Data Relay Capabilities: Wideband and directional radio communications system with built-in scrambler that transmits both audio and video from the cockpit, communications suite and battlefield video. Effective range of 500 miles (800 km); one third that range in the mountains, underground, and during storms. Includes the capability of sending and receiving scrambled/coded audio and video transmissions.

Audio pick-up and filtration system works both multi-directionally and as a shotgun mic. It can pick up sound as quiet as a whisper up to 400 feet away (122 m) and can sift through ambient sound for specific noises. Up to 100 hours of audio can be recorded and kept on file.

NG-V50 Bigfoot

Bigfoot gets its name from the stout, heavy legs and two massive feet required to support this walking artillery battery. Inspired by the Gunbot, the design team of **Carl Gleba**, **Dayton DeFoe** and **Larry Todd Stanley** set out to create a bigger, more powerful walking weapons platform. A robot suitable for use as a walking defensive bunker or medium-artillery platform. Something mercs going to war and nations defending their borders would salivate over. The Bigfoot delivers in spades.

Carrying on the tradition of the Hunter Mobile Gun, the NG Bigfoot is a full-sized, low profile, robotic rifleman designed to hammer enemies with a pair of big guns and a variety of weapons. Its entire upper body is a weapons turret that can rotate 360 degrees and has a 30 degree up and down arc of fire. Its purpose, to inflict grievous damage to giant robots, armored vehicles, fortified positions, and M.D.C. monsters. The big plasma cannons are operated by the pilot, who sits inside the massive weapon turret between the barrels. Above the pilot compartment is a high-powered, four-barreled, gatling gun-style laser cannon. It is mounted on an independent turret so that its gunner can rotate to fire upon other enemy targets and to defend the main guns and robot from incoming attacks by ground troops, flyers and missile volleys.

Another one of NG's walking guns, the Bigfoot has no arms, but does have an advanced radar, sonar and communications suite, with superior sensors and designed to be a battlefield communications relay station. All data collected by the Bigfoot can be transmitted to other combat vehicles and troops within its range of transmission. Moreover, transmissions can be "bounced" from one strategically located Bigfoot, mobile command base or other communications relay system to transmit communiques and data for hundreds, even thousands of miles. This makes the Bigfoot

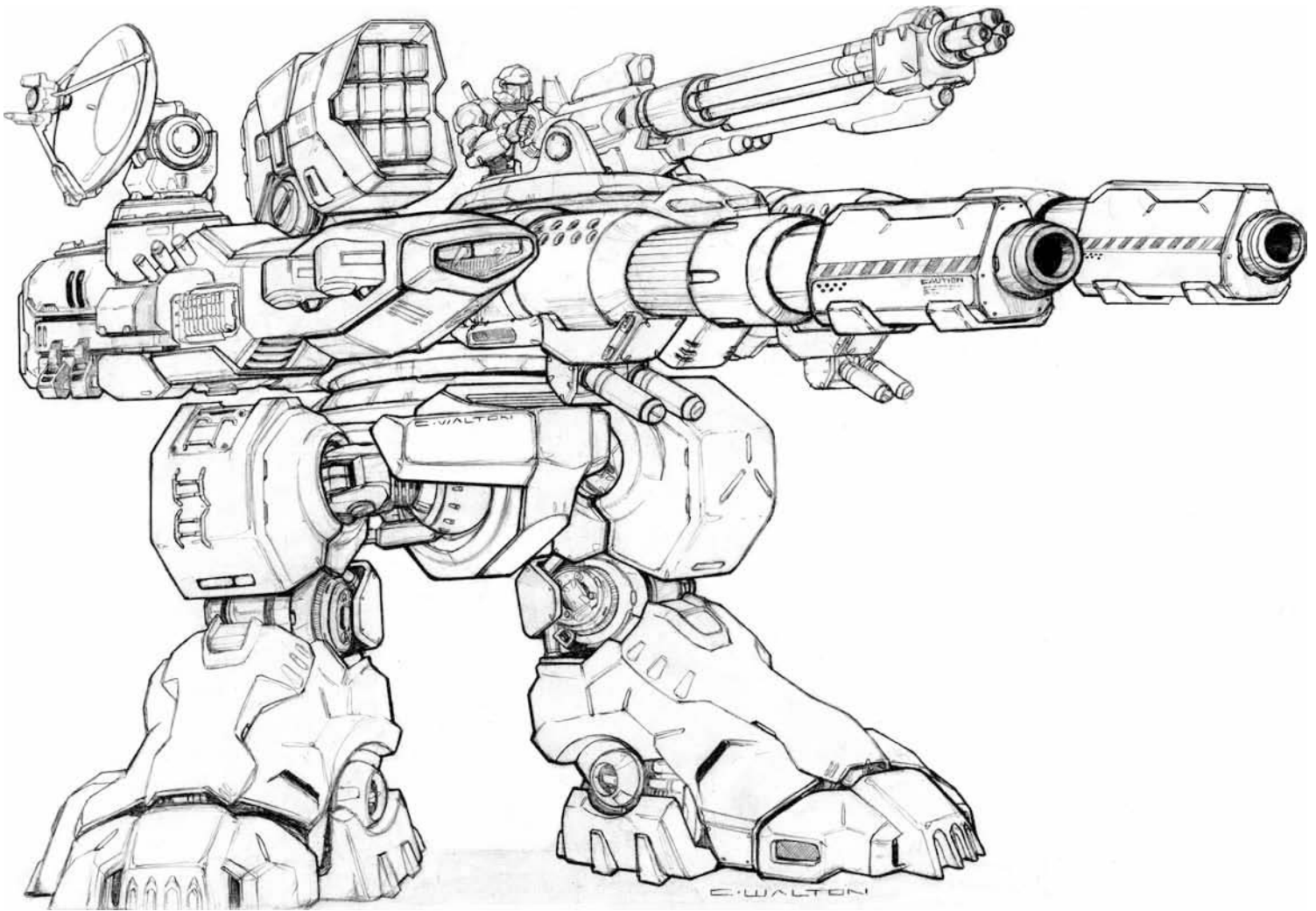

especially valuable to large mercenary companies, armies and defenders of kingdoms and territories with long borders to transmit real-time battlefield targets and information. And it makes this NG robot so much more than another walking tank.

The adjustable, swivel-hips add stability and superior balance for wide stances and positioning on uneven ground. Bigfoot's low profile, huge feet and thick, short legs on hips that can bend and flair out, make it able to remain standing against most ramming attacks, explosions and missile attacks; the odds of knock-down are half the usual number.

In the field, a common strategy is for the Bigfoot to take a strategic position behind cover (wall, bunker, tank, debris, etc.), to cover and protect its legs, and have only the big guns and upper torso vulnerable to frontal attacks.

Bigfoot's main weakness is its slow speed. Ironically, Bigfoot is often used for the defense of NG hovertrains that travel at amazing speeds.

Model Type: NG-V50

Class: Infantry Assault Robot.

Crew: One pilot, one gunner (outside), and one communications officer.

M.D.C. by Location:

- * Main Guns: Plasma Cannons (2) – 220 each
- * Laser Cannon Turret (1, top) – 150
- * Radar & Communications Dish (1, right side) – 90
- * Short-Range Missile Box Launcher (1, right side) – 130

- * Mini-Missile Tube Launchers (4, under main guns) – 12 each
- Communications Suite (1, right side) – 200
- Legs & Feet (2) – 380 each
- ** Laser Cannon Gunner (1, top, outside) – As per body armor.
- ** Pilot's Cockpit (1, between main cannons) – 175
- * Reinforced (inner) Pilot Compartment – 75
- *** Main Body/Upper (center mass and upper torso) – 450

* A single asterisk indicates a small and/or difficult target to strike, requiring the attacker to make a "Called Shot," but even then he is -3 to strike.

** Two asterisks indicates an obstructed view and a difficult target to strike, requiring the attacker to make a "Called Shot," but even then he is -3 to strike (-4 when the robot is moving) and may only be visible from certain angles. **Note:** Reducing the M.D.C. of the Pilot's Cockpit to zero knocks out the main controls and leaves the pilot vulnerable (the Reinforced Pilot's Compartment is exposed). Though the robot can be piloted from the secondary control unit in the Communications Suite, by the comms officer, reduce speed by 30%. Worse, the robot is -1 attack per melee round, the pilot is reduced to being the gunner of the main guns and he can only fire one Plasma Cannon at a time, not both simultaneously.

*** Depleting the M.D.C. of the main body shuts the vehicle down completely, making it useless.

Speed:

Running: 45 mph (72 km).

Leaping: Not possible.

Water: The Bigfoot cannot swim, but can walk along the bottom of lakes and seas at a maximum speed of 20 mph (32 km). Maximum depth tolerance is 2,000 feet (610 m), but the exterior gunner can NOT survive the pressure of such depths unless clad in environmental body armor/power armor or enchanted with magic that protects him.

Flying: Not possible.

Statistical Data:

Height: 26 feet, 5 inches (8 m).

Width: 16 feet (4.9 m) for the upper torso; 11 feet (3.3 m) at the hips, but 20-25 feet (6.1 to 7.6 m) for the feet in most stances.

Length: 32 feet (9.7 m) from the back to the tip of the main guns.

Weight: 24 tons for the robot fully loaded.

Physical Strength: Equal to a Robotic P.S. 35.

Cargo: Minimal, a small locker with enough room for a rifle, pistol, survival kit, 10 gallons (37.9 liters) of water and a few personal items.

Power System: Nuclear; average energy life is 12 years. Solid Oxide Fuel Cell and electric battery versions are NOT available due to the power drain of its weapon systems.

Cost: 49 million credits. Fair availability.

Weapon Systems:

Note: The pilot sits in a separate cockpit. The communications engineer sits in the communications suite, and the laser cannon gunner mans the gun on the outside of the robot. All coordinate their actions with each other. To point the main guns (numbers 1 & 2), the entire upper torso of the Bigfoot must turn and aim like the turret of a tank, but can turn 360 degrees. The upper laser turret can turn 360 degrees on an independent turret.

1. P-6040 "Magma" Plasma Cannons (2): The main guns are a pair of massive plasma cannons – another new design that is still considered a bit experimental. The big guns are forward facing, but the entire upper torso of the Bigfoot can rotate 360 degrees, and the plasma cannons have a 30 degree up and down arc of fire. The weapon has good range and does impressive damage. The pilot is also the gunner for the main guns. He sits in a pilot compartment right between the barrels of the two cannons. He also fires the mini-missiles.

The cannons can be fired one at a time or linked-fire in tandem at the same target simultaneously.

Primary Purpose: Anti-Armor.

Secondary Purpose: Anti-Monster, Anti-Infantry and Assault.

Range: 2,000 feet (610 m).

Mega-Damage: 1D6x10 M.D. per single blast. 2D6x10 per simultaneous dual blast at the same target.

Rate of Fire: Each single or double blast counts as one melee attack/action.

Payload: Effectively unlimited.

2. Defensive Secondary Weapon System of Main Guns: Beneath each of the cannons are a pair of mini-missile tube-launchers, each containing two mini-missiles, four per pair, eight total. These are used against enemies who get too close for comfort and to knockout incoming missile volleys the laser cannon might miss.

Primary Purpose: Defense and Anti-Personnel.

Secondary Purpose: Anti-Missile and Assault.

Range: One mile (1.6 km).

Mega-Damage: Varies with missile type, but typically high explosive (1D4x10 M.D.) or plasma (1D6x10 M.D.).

Rate of Fire: One at a time or in volleys of two or four.

Payload: 8 total; two in each of the four launch tubes.

3. NG-457-RFL Laser Cannon in Turret (1, top): The 457-RFL is built into an open cockpit turret on top of and behind the big guns. The open cockpit means that the gunner has an unobstructed view in all directions with a glance, and in a pinch, anyone can man the turret. While somewhat vulnerable to enemy fire, the laser cannons block most forward attacks, the missile launcher protects him on the right, and he is difficult to see from the ground. Enemies on the ground looking up have a difficult time getting a clear shot at the gunner. They must make a "Called Shot" to hit him and suffer -3 penalty to strike; -4 when the Bigfoot is moving. All the same, it is recommended the designated gunner for the laser turret be clad in heavy body armor or power armor.

The laser cannon turret can rotate 360 degrees and has a 90 degree up and down arc of fire, independent of the Plasma Cannons. This means the big guns can be aiming at one target and the laser cannon can be pointed at a completely different target off to the side or even completely behind the big guns.

The 457-RFL is used to engage the enemy from a distance and is excellent against flyers and incoming missiles, but is suitable against ground targets, troops and vehicles. Its revolutionary gatling gun design enables each of the four barrels to fire in rapid succession. This enables the gunner to pepper and strafe an enemy position with laser fire much like a machine-gun or rail gun, or fire a concentrated burst of four blasts, a split second apart from one another, at one specific target. Both can have a devastating result.

Primary Purpose: Defense and Anti-Aircraft/Flyers.

Secondary Purpose: Anti-Personnel and Assault.

Range: 4,000 feet (1,219 m).

Mega-Damage: A single shot is one laser blast that does 3D6 M.D.; *a carefully aimed*, rapid-fire, four blast burst directed at one target (ideally larger than man-size) does 1D6x10+6 M.D. (most of the blasts hit), but counts as TWO melee attacks. **Note:** *A hastily aimed*, rapid-fire, four blast burst at one specific target does 6D6 M.D. and counts as one attack (only half hit).

Special: Rapid-Fire Strafing Burst: *A spraying, strafing or peppering attack* is always intended to *spray an area* and hit more than one target, or to lay down "suppressing fire" – a hail of energy blasts that should prompt enemy troops to take cover or risk damage or death. It counts as one attack, but the player rolls 1D4 to see how many people *may* actually get struck, then rolls to strike for the burst. Each enemy (or innocent bystander who might become collateral damage) takes 3D6 M.D., all other blasts miss. So for example, the gunner sprays an area with a *strafing burst* where a dozen enemy soldiers are charging forward. Four blasts are unleashed in a sweeping motion. One strike roll is made for the burst. It is a 16 and will hit. Because the attack is directed as a sweeping line of peppering/strafing blasts, not at one target, the shooter rolls 1D4. In this example, the roll is 2. Two of the 12 soldiers each take 3D6 M.D. The next attack, the gunner fires another strafing burst. If a 3 had been rolled, three different targets would have taken damage. If there was only one soldier/target to begin with, only ONE blast out of the four fired hit.

In all cases, a *Strafing Burst* is considered “shooting wild,” so there is a penalty of -6 to strike and no bonuses to strike apply. For the sake of simplicity and expediency, we assume any blast that “missed” does not hit any other personnel and flies off to do no significant damage. But please, use common sense. If there is a large wall or giant vehicle, machinery, etc., too large to be missed behind the targets getting sprayed, the blasts that miss will hit and do damage to whatever is immediately behind them and in the line of strafing fire.

Rate of Fire: Single blast, hastily aimed rapid-fire burst of four blasts (can only fire once or a burst of four), or strafing burst counts as one melee attack. A carefully aimed burst counts as two attacks.

Payload: Effectively unlimited.

4. Short-Range Missile Launcher (1, Right Side): Atop the communications suite is a short-range missile launcher (exhaust ports in the back). It too is built on a turret that can rotate 360 degrees and has a 45 degree, up and down arc of fire. The launcher can also slide down to the side of the communications suite when not in use, where it is less noticeable, located between the main guns and the suite. This weapon can be fired by the communications officer or the pilot.

Primary Purpose: Anti-Armor and Anti-Fortification.

Secondary Purpose: Anti-Monsters and Assault.

Range: Varies, but typically 5 miles (8 km).

Mega-Damage: Varies with missile type, but typically *fragmentation* (2D4x10 to a 20 foot/6.1 m blast radius), *high explosive* (2D6x10 M.D. to a 15 foot/4.6 m radius), *armor piercing* (2D6x10 M.D. to a 5 foot/1.5 m radius) or *plasma* (2D6x10 M.D. to a 15 foot/4.6 m blast radius, but plasma and fragmentation missiles only have a 3 mile/4.8 km range).

Rate of Fire: One at a time or in volleys of two or four.

Payload: 10 total.

5. Communications and Sensor Suite (1): Mounted on the right of the Bigfoot, where an arm might be expected, is an entirely separate compartment known as the *Communications Suite*. It is here that the sensors, radar, and communications systems are located. A dedicated systems engineer/communications officer sits inside in a reclined position, surrounded by monitors and data feeds. Atop of it is a radar and communications transmitter and relay dish. A large, short-range missile launcher is located on the left side of the suite between the radar dish and the laser turret to the left.

All sensor systems are advanced, military grade with enhanced radar, sonar and communications systems designed to be a battlefield communications relay station. All data collected by the Bigfoot can be transmitted to other combat vehicles and troops within its range of transmission. Moreover, transmissions can be “bounced” from one strategically located Bigfoot, or a mobile command base, or communications relay tower, etc., to transmit communique and data. If positioned right, this can create a mobile relay network that can stretch for hundreds, even thousands, of miles. This makes the Bigfoot especially valuable to large mercenary companies, armies and defenders of kingdoms and territories with long borders to transmit *real-time* battlefield information and targets. This alone makes Bigfoot so much more than another walking tank.

All standard robot sensor systems, plus the following:

A. Enhanced Radar: Can identify and simultaneously track up to 120 different targets. **Range:** 100 miles (160 km). **Note:**

Includes an extensive Identify Friend and Foe (IFF) database. This system can identify a target and assign it priority based on known abilities and threat level. Provides bonuses to all combat robots, tanks and power armor within a one mile (1.6 km) radius of the Bigfoot receiving the data transmission: +1 on initiative and +1 to strike. This bonus also applies to the Bigfoot itself.

B. Enhanced Sonar: Can identify and simultaneously track up to 96 different targets for underwater operation. **Range:** 50 miles (80 km). Same IFF and relay capabilities as radar.

C. Communications and Data Relay Capabilities: Wide-band and directional radio communications system with built-in scrambler that transmits both audio and video from the cockpit, communications suite and battlefield video. Effective range of 500 miles (800 km); one third that range in the mountains, underground, and during storms. Includes the capability of sending and receiving scrambled/coded audio and video transmissions.

Audio pick-up and filtration system works both multi-directionally and as a shotgun mic. It can pick up sound as quiet as a whisper up to 400 feet away (122 m) and can sift through ambient sound for specific noises. Up to 100 hours of audio can be recorded and kept on file.

A tactical camera can record up to 48 hours of footage into memory. Video footage can also be transmitted live to one or more receivers, or stored and sent at a later time. Such footage is usually used for combat analysis, field studies and combat training. The camera sees directly ahead in the direction the pilot faces.

D. Built-in Language Translator: Programmed with the nine known languages of the Americas and can hold 12 additional languages. It can recognize and monitor up to three different voices and two different languages or dialects at once. Level of accuracy is 98.7% with a three second delay when directed at one individual, but drops to 78% with a six second delay when translating three speakers simultaneously.

E. Thermal-Imager: A special optical heat sensor that allows the infrared radiation of warm objects to be converted into a visible image. Enables the pilot to see in the dark, in shadows, and through smoke. **Range:** 2,000 feet (610 m).

F. Infrared and Ultraviolet Optics: This optical system projects a beam of infrared light that is invisible to the normal eye. The infrared beam enables the pilot to see in the dark and to see other infrared beams. The ultraviolet system enables the pilot to see into the ultraviolet spectrum of light and is mostly used to detect the light beams of ultraviolet detection systems. **Note:** The infrared light beam can be seen by anybody who also has infrared optics, and the beam can be traced back to its source. Smoke impairs the infrared beam, making it impossible to see.

G. Nightvision Optics: Passive light amplification that allows the pilot, gunner and communications officer to see in the dark as long as there is at least some ambient light. 2,000 foot (610 m) range, but is completely useless in total darkness.

H. Smoke Grenades (3): Located on the lower right side of the communications suite are three smoke grenade launchers. Smoke is used to help cover retreats or as a signal.

6. Hand to Hand Combat: Rather than use a weapon, the pilot can engage in M.D. hand to hand combat. See *Heavy Ground Robot Training* on page 352 of **Rifts® Ultimate Edition** for

the number of attacks and bonuses. However, the Bigfoot can *not* perform Punches or Power Punches as it has no arms or hands. Nor can it perform a Leap Kick. Stomps are only effective against targets smaller than 5 feet (1.5 m) tall.

AX-44 Bison Battler

The Bison originates from the battle-pits of the Robot Gladiatorial Arena; hence its more stylized, animal appearance, an unusual characteristic for the military hardware look of most Northern Gun robots. The Bison robo-gladiator was an NG creation, commissioned for fun by the R&D department and first entered into competition 16 years ago where it became an immediate fan favorite. It won so many battles over so many years, heralding so many champions and memorable campaigns, that some of the Northern Gun executives decided to create an inexpensive, commercial model to sell to the public. The original plan was to make it a limited edition, but sales were so strong when the Bison was released five years ago, and it remains such a popular brand, that NG has kept it on the market and has given it full distribution.

It was the unenviable task of **Jason Dvorchak**, **Bryan Ellis**, **Matt Clements** and **Benjamin M. Mumah** to turn an icon from the Robodome into a functioning, battle worthy, general purpose exploration and combat robot for use in the field. More than that, the public would have high expectations for the champion robot, so the Bison had to live up to its reputation of being a hard-fighting, battle robot that could take a licking and still get to kick some . . . well, you get the idea. This could not be some cutesy, second-rate vanity release to make a few credits.

It helped that the members of the design team were, themselves, fans of the Robodome games and of the Bison. As a result, they made an outline of what they loved about the robot in the arena, and built on those qualities and characteristics. The first decision, to keep its minotaur appearance. Their second decision, to make it a battler. As a gladiator robot, the **NG AX-44 Bison** is best suited for close combat, where its shovel-like fingers can chop, stab and tear apart other robots and power armor, as well as maul armored vehicles. A favorite attack in the arena is for the Bison to hold its wide, solid fingers pressed together to deliver *Karate style* blows that literally slice, chop and whittle down combating robots. A power punch delivered in this fashion not only inflicts double damage, but can punch right into the chest or lower abdomen of opposing robots as well as sever weapons and limbs. In the Robodome, such an attack is known as the "*Bison Death Fist*," and always sends the crowd cheering and on its feet, especially if the impaling hand of the Bison is removed from the opposing robot, fist clenched and clutching wires and parts. The fingers and hands, with tapered and sharp fingertips designed for impaling and chopping, create a shovel-blade weapon when locked in place. This works to the robot's advantage in the wilderness, where the hands can be used as giant scoops for digging and mining, excavating ruins, chopping through barriers of debris and fallen trees, tearing down salvage and chopping wood.

Another favorite gladiatorial attack is the "Bison Slam," in which the hunched-back robot lowers its head and runs, full-steam, into the chest, back or legs of an opposing robot. The horns are Vibro-Blades and the heavy-duty hydraulics and shock absorbers in the neck enable the Bison to hit like a Mack truck without the impact doing damage to itself or its pilot. Though the

eyes glow red and smoke rises from a vent under the nose, the head is nothing more than a solid battering ram. The pilot sits in the hump of the robot's back, completely enclosed and cushioned in a cockpit designed to handle ram attacks, body blocks, head butts and violent falls. The robot pilot "sees" via a number of tiny, shock-resistant cameras concealed on the robot's body – the small circles on the head (2), chest (4), hump (2; front), shoulders (1 in each), and back (2); 11 total. They are so small and concealed that most opponents don't even notice them.

The weapons on the forearms are also carried over from the arena. The right forearm is a flamethrower which is ideal against ground troops, monsters and animals (fire holds at bay and chases away most animals and many monsters). The left forearm is a short-range, double barrel ion blaster (can be substituted for an S.D.C. machine-gun and can fire silver-tipped rounds). To give the Bison long-range, "real world" punch capabilities, a heavy plasma cannon has been slapped onto the right shoulder. (Can be substituted with a laser cannon or rail gun, though the latter has a very limited payload.) The Bison's thick, shovel-blade fingers prevent it from using any handheld firearm, and even holding giant-sized melee weapons is difficult (-2 to strike, parry and all related combat moves).

Though the Bison is best suited to close combat and has limited other uses, its popularity in the NG Robot Arena, combined with its unique combat capabilities, good speed and comparatively low cost (and low M.D.C.), has made it popular among miners, salvage operations, adventurers, fortune hunters, bandits, raiders, and even many mercenary companies and explorers. Depending



on how the Bison is used, it can be a very effective siege weapon to tear down or punch through fortified walls and bunkers (assuming it can get close enough), as well as salvage operations, and fighting Xiticix and other monsters in hand to hand combat. Against Xiticix, the Bison can tear its way into hives, punch through interior walls, navigate its tunnels, chop up nests, smash eggs, and handle well against the insectoid warriors, though hit and run tactics with a timely and hasty retreat give the robot pilot his best odds of survival. Even the CS has taken note of how well the Bison does in combat against Xiticix, and how well it does in the hives.

Model Type: Bison Combat Robot.

Class: AX-44 (Gladiator) Medium Combat Robot.

Crew: One pilot. There is only enough room to stow personal body armor, a backpack, bedroll, some extra gear, and water. The pilot's seat can also recline for reasonably comfortable sleeping.

M.D.C. by Location:

Shoulder-Mounted Plasma Cannon – 100

** Head/Battering Ram – 125

Arms (2) – 180 each

* Hands (2) – 100 each

* Forearm Flamethrower – 30

* Forearm Ion Blaster – 30

Legs (2) – 210 each

Reinforced Pilot Compartment – 100

*** Main Body – 390

* A single asterisk indicates a small and difficult target to strike, requiring the attacker to make a "Called Shot," but even then the attacker is -4 to strike.

** Destroying the head of the robot has no effect other than taking away the pilot's ram attack. The pilot actually sits in the robot's chest and sees via a handful of concealed cameras in the front and back of the 'Bot. The head takes no damage when it rams an opponent or object.

*** Depleting the M.D.C. of the main body shuts the vehicle down completely, making it useless.

Speed:

Running: 60 mph (96 km).

Leaping: 8 feet (2.4 m) high and/or across.

Water: The Bison is too ungainly to swim, but it can walk along the bottom of the sea or lake bed at 20 mph (32 km). Maximum depth tolerance is 800 feet (244 m).

Flying: Not possible.

Statistical Data:

Height: 21 feet (6.4 m).

Width: 10 feet (3 m).

Length: 8 feet (2.4 m).

Weight: 12 tons.

Physical Strength: Robotic P.S. of 35.

Cargo: There is a small locker built into the pilot compartment large enough to hold a rifle, pistol and survival kit. The Bison also features a water filter system with a three gallon (11.4 liter) water tank.

Power System: Nuclear; average energy life is 10 years. Solid Oxide Fuel Cell and electric battery versions are also available.

Cost: Nuclear: 21 million credits for a new or almost new robot with a full weapons load. Solid Oxide: 18 million credits. Electric battery: 16 million credits.

Weapon Systems:

1. Shoulder-Mounted Plasma Cannon: The Bison's main gun is a reliable plasma cannon with limited range, but excellent damage output. The plasma cannon has been mounted "Glitter Boy style." Much like a GB's Boom Gun, the cannon can flip back and out of the way when not in use, allowing the Bison to perform other jobs.

Primary Purpose: Anti-Armor.

Secondary Purpose: Assault.

Range: 1,500 feet (457 m).

Mega-Damage: 6D6 M.D. per blast.

Rate of Fire: Single shot only. Each blast counts as one melee attack.

Payload: Effectively unlimited: tied into the power supply of the robot.

Bonus: Laser targeting standard; +1 to strike on aimed shots.

2. Light Flamethrower (1): Located on the robot's right forearm is a flamethrower. It can be used to chase off wild animals and monsters, start fires, flush out bunkers and scatter people without armor protection. The flamethrower is designed to be waterproof and is usable on the surface of the water, but comes with valves that automatically seal it off underwater, deactivating it and preventing water from contaminating the napalm reserve.

Primary Purpose: Anti-Monster and Anti-Personnel.

Secondary Purpose: Defense and Assault.

Range: 150 feet (46 m).

Mega-Damage: 3D6 M.D. to the target and anyone within 5 feet (1.5 m). Those caught within reach of the flamethrower's attack inside small, enclosed areas like bunkers, caves or non-sealed vehicles and without environmental gear or oxygen, will have to roll to save vs poison (smoke inhalation and lack of air) or be rendered unconscious for 1D4 melee rounds.

Rate of Fire: Each burst counts as one melee action/attack.

Payload: Approximately 18 bursts. The flamethrower can be refueled with military-grade napalm or use normal diesel or gasoline (reduces damage to 1D6 M.D.). 29 gallon (110 liter) fuel reserve.

3. Ion Blaster (1): Located on the robot's left forearm is a double-barrel, short-range ion blaster. Point and shoot.

Primary Purpose: Anti-Personnel.

Secondary Purpose: Defense.

Range: 1,200 feet (366 m).

Mega-Damage: 3D6 M.D. per single blast, 6D6 M.D. per simultaneous dual blast at the same target.

Rate of Fire: Each single or double blast counts as one melee attack.

Payload: Effectively unlimited.

4. Eye Lasers (2): Each of the Bison's eyes is actually a backup laser weapon designed to be used when the pilot's arms are occupied, when ammo is low or when the plasma cannon is not available.

Primary Purpose: Anti-Personnel.

Secondary Purpose: Defense.

Range: 1,200 feet (366 m).

Mega-Damage: 2D6 M.D. per blast, or 4D6 M.D. for a linked blast.

Rate of Fire: Each single or dual blast counts as one melee attack.

Payload: Effectively unlimited.

5. Handheld Weapons: Due to the shovel-blade design of its hands, the Bison cannot use giant-sized guns. Giant-sized melee weapons, clubs, etc. can be gripped and used, but at a penalty of -2 to strike, parry and disarm.

6. Hand to Hand Combat: Rather than use a built-in weapon system, the pilot of the Bison can engage in Mega-Damage hand to hand combat as detailed below. See *Light Ground Robot Training* on page 353 of **Rifts® Ultimate Edition** for the number of attacks and bonuses.

Restrained Punch – 1D4 M.D.

Normal Punch – 2D4 M.D.

Normal Head Butt – 2D4 M.D.

Head Butt with Vibro-Horns Turned On – 2D6+6 M.D.

Claw Strike/Raking with Claws – 2D4+4 M.D.

Karate Chop/Punch – 2D4+6 M.D.

Karate Chop Stabbing/Impaling Strike – 2D4+8 M.D.

Karate Power Punch (chop/slice or impaling attack) – 4D4+16 M.D., but counts as two melee attacks.

Stomp – 1D4 M.D.

Running Ramming Attack – 4D6 M.D. (+10 if Vibro-Horns are used) and there is an 86% likelihood of knockdown against opponents of the same size, smaller and up to 30% larger. 60% chance against larger opponents up to twice the Bison's size. +10% to knockdown if the opponent's leg is targeted and successfully caused to buckle. Victims of knockdown lose initiative and two melee attacks. **Note:** This ram attack counts as two of the Bison's own attacks.

7. Sensor System Note: The Bison has all the standard robot features.

Blocker Combat Robot

The Blocker is something new from the creative minds of **Robb Dunn, Steven Carroll, Charles Walton** and **Benoit Provencher**. As the robot's name suggests, one can think of the robot as a giant, mechanical linebacker that punches holes through the enemy line using raw physical power, its shield and firepower. Actually, the Spartans of ancient Greece and the ancient Romans' use of large shields to create a mobile wall to block attacks, punch through enemy lines and create phalanx positions were their initial inspirations.

The Blocker's most unique feature is its large shield that comes as standard equipment. Mounted on the robot's back for carrying, the shield is a slatted metal frame, with sheets of M.D.C. panels that fall away as their M.D.C. is exceeded. This, in effect, creates several layers of M.D.C. protection, and creates a shield that can eat up damage from energy blasts and incoming missiles, and distributes the impact of shrapnel. The robot itself blocks such attacks by hiding behind the shield, dropping it to make attacks, though the shield is designed so the robot's head can peek over it and fire its main gun. The shield is a giant version of a pre-Rifts tank armor accessory that was made to reduce the effectiveness of RPGs and other armor-piercing weapons. It doesn't neutralize missiles or explosive damage, but cuts back on their damage greatly and cancels out the blast radius effects.

Blockers are heavily armored and have a number of concealed weapons, such as their chest mini-missile launchers, forearm guns, and other features. They are typically front-line infantry 'Bots designed to punch through enemy lines and defensive posi-

tions, but also make decent wilderness exploration and construction robots. They are usually paired with other infantry robots. They are tough hombres in any fight, and function well as sentry robots as well as a rearguard covering the retreat of infantry soldiers, or act as a designated interceptor to block and stall other robot and giant monster attackers. Blockers can take lots of damage and keep on fighting, and their entire design is made to survive as walking battering rams and robot phalanx lines. There are redundant backups for everything and an advanced fire-suppression system that prevents the pilot from cooking alive under even worst-case scenarios.

Model Type: NG-V19

Class: Infantry Assault Robot.

Crew: One pilot with room for one passenger or gunner.

M.D.C. by Location:

* Head Laser Turret – 180

* Wrist Ion Blaster (2, one per forearm) – 60 each

Arms (2) – 280 each

* Hands (2) – 80 each

Legs (2) – 300 each

Feet (2) – 130 each

Shield (1) – 300

Reinforced Pilot Compartment – 100

** Main Body – 570 (heavily armored)

* A single asterisk indicates a small and difficult target to strike, requiring the attacker to make a "Called Shot," but even then the attacker is -4 to strike.

** Depleting the M.D.C. of the main body will shut the vehicle down completely, making it useless.

Speed:

Running: 65 mph (104 km).

Leaping: 8 feet (2.4 m) high and lengthwise, increase 50% with a running start.

Water: The Blocker cannot swim, but can walk along the bottom at 22 mph (35 km). Maximum depth 1,000 feet (305 m).

Flying: Not possible.

Statistical Data:

Height: 31 feet (9.5 m).

Width: 16 feet (4.8 m).

Length: 12 feet (3.6 m).

Weight: 28.5 tons.

Physical Strength: Robotic P.S. 40.

Cargo: Minimal, a small locker with enough room for a rifle, pistol, survival kit and a few personal items.

Power System: Nuclear; average energy life is 20 years. Solid Oxide Fuel Cell and electric battery versions are also available.

Cost: Nuclear: 32 million credits. Solid Oxide: 28 million credits. Electric battery: 25 million credits.

Weapon Systems:

1. Laser Turret: The Blocker's main weapon is the snub-nosed laser turret that is its "head." The pilot operates the robot from within a compartment mounted safely in the chest, so blowing off the head will not harm the pilot. The "head" is a high-powered laser built into a turret that can rotate 360 degrees to shoot in any direction and has a 45 degree up and down arc of fire.

Primary Purpose: Anti-Armor.

Secondary Purpose: Anti-Aircraft.

Range: 3,000 feet (914.4 m).



Mega-Damage: 6D6 M.D.

Rate of Fire: Each blast counts as one melee action/attack.

Payload: Effectively unlimited.

2. Chest Mini-Missile Launchers (2): Built into the right and left side of the chest is another concealed weapon: mini-missile launchers. Always fired by the pilot.

Primary Purpose: Anti-Armor.

Secondary Purpose: Anti-Personnel.

Range: About one mile (1.6 km).

Mega-Damage: Varies with missile type. Plasma (1D6x10 M.D.) and Armor Piercing (1D4x10 M.D.) are standard.

Rate of Fire: One at a time or in volleys of two or four.

Payload: 36 total; 18 missiles per each chest launcher.

3. Quad Ion Blasters (2, one each arm): Built into the right and left forearms are extendible and retractable concealed ion blasters. When needed, they pop up, blast away, and when done, lower back into the arms. The Blocker Shield is held in one hand and the wrist blaster fired from the other. Always fired by the pilot.

Primary Purpose: Anti-Personnel and Assault.

Secondary Purpose: Defense.

Range: 1,200 feet (366 m).

Mega-Damage: 3D6 M.D. per single blast, 6D6 per twin blast, 1D4x10+6 M.D. per triple blast, or 1D6x10+8 M.D. per simultaneous quadruple blast. **Note:** Both arms can not be linked to fire simultaneously at the same time.

Rate of Fire: Each single or multi-shot blast directed at the same target counts as one melee attack.

Payload: Effectively unlimited.

4. Blocker Shield: The Blocker shield is 24 feet (7.3 m) tall and 12 feet (3.6 m) wide. It is a series of loose slats with enough space in between them that the shock wave of a missile's explosion dissipates rather than being flatly absorbed, so all missile, grenade and explosive attacks do half damage and inflict no blast radius damage. Energy blasts and rail gun rounds do full damage. As the shield loses M.D.C., its armored "slats" or panels drop away to reveal new ones underneath. When the shield's M.D.C. is reduced to zero, it is nothing but a piece of framework with shredded scraps of armor dangling from it. At that point, the shield is useless and offers no protection. **Note:** See #5 for Special Shield Attacks.

5. Hand to Hand Combat: Rather than use a built-in weapon system, the pilot can engage in Mega-Damage hand to hand combat inflicting damage as per Robot P.S. of 40. See *Heavy Ground Robot Training* on page 352 of **Rifts® Ultimate Edition** for the number of attacks and bonuses. Plus the Blocker gets the *Special Shield Attacks* listed below when using its shield as a weapon:

Shield Strike – 2D6+6 M.D.

Two-Handed Shield Power Punch (A chopping or stabbing attack with the pointed bottom of the shield. Most effective in a downward motion.) – 4D6+12 M.D., but counts as two melee attacks.

Normal Body Block with Shield – 2D6+6 M.D.

Running Shield Ramming Attack – 4D6+8 M.D. and there is a 90% likelihood of knockdown against opponents of the same size, smaller and up to 30% larger. 66% chance against larger opponents up to 150% larger than the Blocker. **Note:** This ram attack counts as two of the robot's own attacks.

6. Sensor System Note: The Blocker has all the standard robot features.

NG-V32 Bruiser

The success of the Bison made R&D engineers **Stephen B. Keith, Peter Porcaro Jr.,** and **Jason Cogshall** wonder if there might be a market for other, heavily armored robots that specialized in close combat. Keeping the Xiticix threat in mind and the Bison's success at fighting the monsters in close quarters, the team developed the Bruiser. A close combat robot that is most effective in close quarters, urban streets, thick forests and fighting infantry troops and other giant robots.

The Bruiser is armed with ion beam weapons mounted on its shoulders, mini-missile launchers in the shoulders, and a pair of laser eyes (the other circular shapes recessed in the face are cameras, and an infrared searchlight). But its namesake weapons are its high-impact fists and piston arms, capped with dangerous "brass knuckles" that pulverize M.D.C. flesh and steel. Versatility is always a consideration in Northern Gun designs, and the hammering fists are also suitable for punching through sealed doors and air hatches, walls and fortifications, and shattering

stone. The Bruiser's punches are so strong they can upend light M.D.C. vehicles and stop a charging Rhino-Buffalo in its tracks.

The Bruiser released just three years ago and has proven to be a popular model for use in a wide range of combat and construction operations, as well as gladiatorial combat. The robot's ability to hammer enemies with its fists while essentially providing its own cover fire makes it particularly deadly in confined arenas and point-blank firefights. It has performed extremely well against Xiticix in and outside of their hives as well as against monsters and in street combat.

Model Type: NG-V32 Bruiser.

Class: Infantry Assault Robot.

Crew: One pilot and one gunner sitting back to back.

M.D.C. by Location:

* Head – 115

* Mini-Missile Launchers (2, shoulder) – 35 each

* Twin Ion Beam Turrets (2, shoulder mounted) – 75 each
Arms (2) – 195 each

* High-Impact Piston Fists (2) – 125 each

Legs (2) – 215 each

Reinforced Pilot Compartment – 100

** Main Body – 420

* A single asterisk indicates a small and difficult target to strike, requiring the attacker to make a "Called Shot," but even then the attacker is -4 to strike. **Important Note:** The sensor head and eyes of the robot is one of its weaknesses. Destroy the head and all sensors are lost and only the gun cameras on the ion beam turrets remain. Destroy them, and the Bruiser is "blind." The 'Bot is new enough that most people don't realize this.

** Depleting the M.D.C. of the main body will shut the vehicle down completely, making it useless.

Speed:

Running: 90 mph (144 km).

Leaping: 10 feet (3 m) high and lengthwise, increase by 50% with a running start, and 30 feet (9.1 m) at a speed greater than 60 mph (96 km).

Water: The Bruiser cannot swim, but can walk along the lake bed at a maximum speed of 30 mph (48 km). Maximum depth 1,000 feet (305 m).

Flying: Not possible.

Statistical Data:

Height: 22 feet (6.7 m).

Width: 16 feet (4.8 m).

Length: 10 feet (3 m).

Weight: 22 tons.

Physical Strength: The hydraulic arms and hammering fists have a Robot P.S. 45! One of NG's strongest robots; however, all that power is delivered as pile-driver punches and all in the arms/fists. Overall, when it comes to lifting and pulling, the Bruiser has a Robot P.S. of 35.

Cargo: Minimal, a small locker with enough room for a rifle, pistol, survival kit and a few personal items.

Power System: Nuclear (the most common); average energy life is 20 years. Solid Oxide Fuel Cell and electric battery versions are also available.

Cost: Nuclear: 27 million credits. Solid Oxide: 23 million credits. Electric battery: 19 million credits.

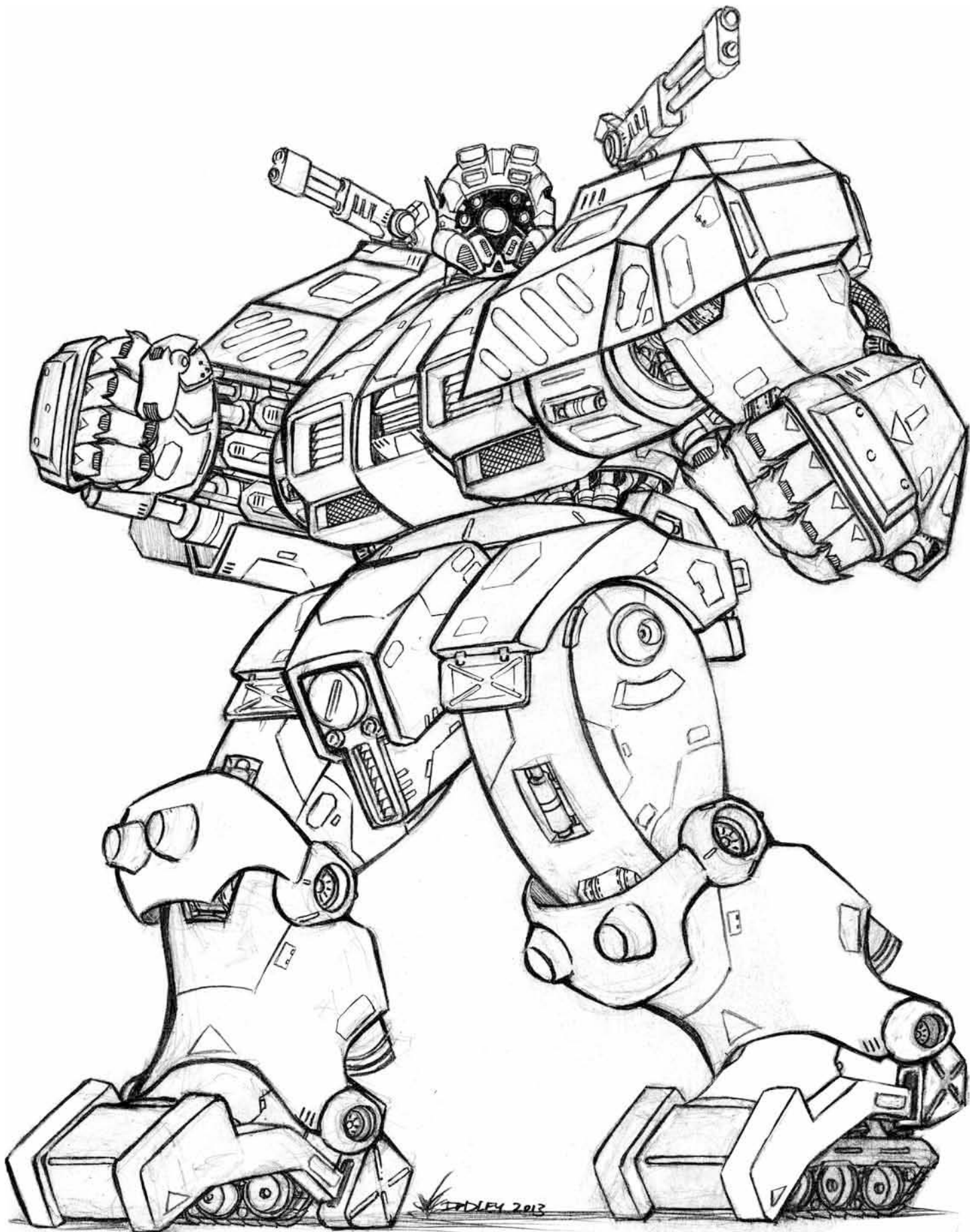

Weapon Systems:

1. High-Impact Piston Arms & Super Punches: The Bruiser gets its name from its hardhitting, pile-driver M.D.C. fists. Loaded on heavy hydraulic pistons, they can be “fired” to slam forward into an enemy robot, armored vehicle, door or fortification with incredible power. Given just a few minutes, a Bruiser can break down and pulverize M.D.C. walls and fortifications faster than most teams of sappers.

Primary Purpose: Anti-Armor.

Secondary Purpose: Anti-Fortifications and Defense.

Range: Close combat with a reach of 15 feet (4.6 m).

Mega-Damage: As indicated below based on P.S. 45 and hydraulics.

Jab – 2D6 M.D.

Elbow Strike – 3D6 M.D.

Full Strength Punch – 3D6+2 M.D.

Power Punch (piston driven) – 1D6x10+2 M.D. Targets smaller than 13 feet (3.9 m) have 01-55% chance of being knocked off their feet and thrown 1D4x10 feet (3 to 12.2 m) by the impact. Those knocked off their feet lose initiative and two melee attacks. *Counts as two melee attacks.*

One-Two Punch: 2D6x10+3 M.D. from a pair of rapid-fire punches, first from one fist and then the other. *Counts as three melee attacks.* Knockdown same as power punch, above. The arms and hips are designed to swivel and move in such a way as to allow this rapid hammering attack.

Bonus: +1 melee attack if the Bruiser uses its fists for all attacks in an entire melee round.

2. Twin Ion Beam Turrets (2; light): Mounted over and above the shoulder are twin ion beam turrets. Each turret can move independent of the other or in tandem for linked fire. Each can rotate 360 degrees and has a 90 degree up and down arc of fire. Only one gunner controls both turrets, while the pilot handles all other functions. These guns are intended to cover the Bruiser from incoming missiles and attackers while it hammers through enemy defensive walls, or engages an enemy robot in brawling fisticuffs. The gunner can use the elevation and independent aiming of the ion beams to fire at targets in two different directions, or combined fire against a single target. The gun cameras also function as an extra set of eyes that let the gunner or pilot look behind him/her or keep a watch on the sky. They also come in handy as backup in the event that the cameras and sensor system in the robot’s head are knocked out.

Primary Purpose: Anti-Armor and Assault.

Secondary Purpose: Anti-Personnel and Defense.

Range: 1,600 feet (488 m).

Mega-Damage: 5D6 M.D. for a single blast, 1D6x10 M.D. for a dual blast fired simultaneously at the same target.

Rate of Fire: Each single or dual blast counts as one melee attack/action.

Payload: Effectively unlimited. 50 dual blasts per charge for electric battery models of the robot.

Independent Targeting: +1 to strike.

3. Mini-Missile Launcher: The Bruiser’s only weapon to contend with long-range opponents is its mini-missile launcher. A hatch in the right and left upper shoulder slides open to launch missiles. For the Bruiser’s main job of hunting other robots, however, leading an attack with a salvo of missiles followed by its hammering fists is a deadly combination.

Primary Purpose: Anti-Armor and Assault.

Secondary Purpose: Anti-Personnel and Defense.

Range: About one mile (1.6 km).

Mega-Damage: Varies with missile type. Plasma (1D6x10 M.D.) and Armor Piercing (1D4x10 M.D.) are standard.

Rate of Fire: One at a time or in volleys of two or four.

Payload: 16 total missiles, 8 in each shoulder.

4. Eye Lasers (2): Two of the lights that glow from inside the Bruiser’s recessed face are two backup lasers designed to be used when the pilot’s arms are occupied or when the other energy weapons are offline.

Primary Purpose: Anti-Personnel.

Secondary Purpose: Defense.

Range: 1,200 feet (366 m).

Mega-Damage: 2D6 M.D. per blast, or 4D6 M.D. for a linked blast.

Rate of Fire: Each single or dual counts as one melee attack.

Payload: Effectively unlimited.

5. Sensor System Notes: Basic robot systems, plus the following enhanced optics systems.

A. Thermal-Imager: A special optical heat sensor that allows the infrared radiation of warm objects to be converted into a visible image. Enables the pilot to see in the dark, in shadows, and through smoke. **Range:** 1,200 feet (366 m).

B. Infrared and Ultraviolet Optics: This optical system projects a beam of infrared light that is invisible to the normal eye. The infrared beam enables the pilot to see in the dark and to see other infrared beams. The ultraviolet system enables the pilot to see into the ultraviolet spectrum of light and is mostly used to detect the light beams of ultraviolet detection systems. **Range:** 1,200 feet (366 m). **Note:** The infrared light beam can be seen by anybody who also has infrared optics, and the beam can be traced back to its source. Smoke impairs the infrared beam, making it impossible to see.

C. Infrared Searchlights: Located in the center of the face is an infrared searchlight. Only somebody who can also see infrared light will see the beam. **Range:** 500 feet (152 m), but the entire head must move/look in the desired direction.

D. Multi-Camera System of Eyes (4): The Bruiser has four camera eyes in its head with which to see, plus a gun camera for each ion beam gun. 4,000 foot (1,219 m) range with telescopic lenses as well as macro-lenses for close work and focusing on locks, hinges, stress lines, etc. Includes image and video transmission capabilities.

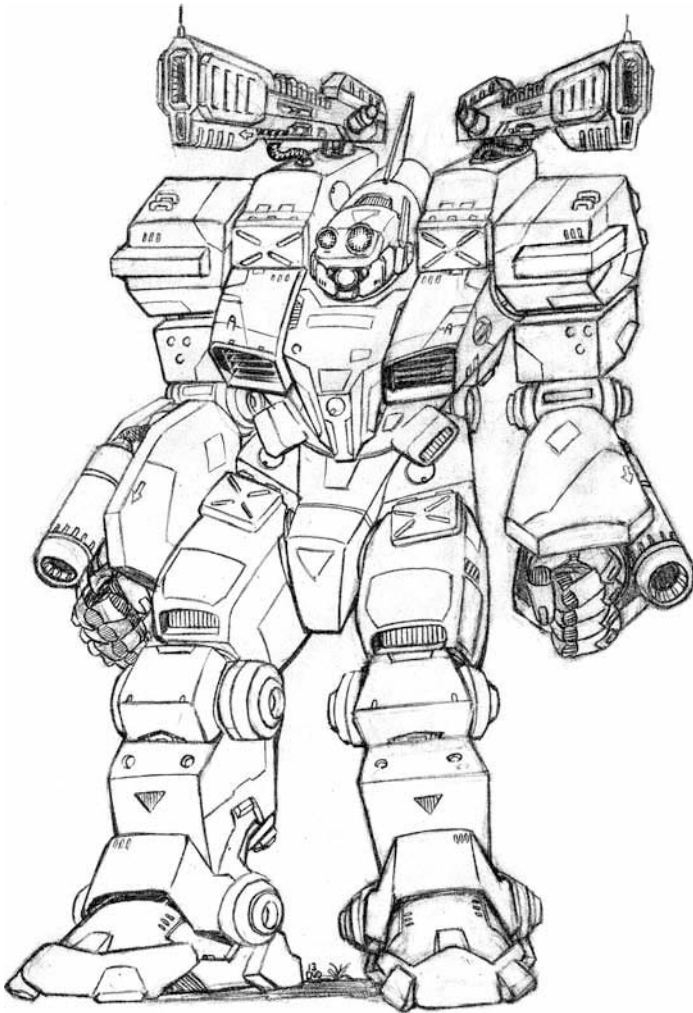

NG-V34 Buffalo

The **Fillinger design team**, headed by **Jason Chapman, Glenn Cole** and **Mark Dudley**, see the Buffalo as a mainline combat robot. A walking bunker suitable for city and perimeter patrols, escort operations and guard duty. A high-powered robot that when its position is attacked, or when on patrol runs into something big, dangerous or armored, has the heavy-hitting firepower to take it down without having to call for reinforcements. The two particle beam cannons mounted above the head are the robot's "buffalo horns." They can rotate 360 degrees and have a 45 degree arc of fire. Each has its own gunner and can operate independent of each other to attack two different targets, or engage in linked fire to pulverize the same target simultaneously. Mounted on each forearm is a plasma ejector, and the Buffalo has a few dozen mini-missiles for an additional wallop. It can, of course, also engage in hand to hand combat. The Buffalo's hands are fully articulated and able to use giant-sized, handheld weapons, tools, and explosives, as well as climb and perform other functions that require dexterity and control.

The Buffalo can handle anything from monsters and dinosaurs to heavily armored assault vehicles and other combat robots. While it has a battery of weapons that do heavy damage, their ranges are rather short compared to lasers, rail guns and other types of long-range weapons. This means the Buffalo is put to best use in urban environments, guarding tunnels (or guarding anything), perimeter and street patrols, ambushes and cross-

fires, and any combat environment where the battle is confined to a limited space. Need to hold a mountain pass, a doorway or stronghold? Want to invade and take down a Xiticix hive, or fight on the street? The Buffalo is the robot for the job. A powerhouse that can go toe to toe with swarms of Xiticix or the robots of the Coalition States, Triax and the Splugorth's Kittani. Put it out in the open without cover, however, and enemies with the advantage of long-range weaponry (can fire farther than 1,600 feet/488 m) will shred the Buffalo to pieces before it gets close enough to fire off a shot. Despite the Buffalo's range limitations, it enjoys good sales, especially among mercenaries guarding towns and city-states, city patrols, and small militaries.

Model Type: NG-V34

Class: Infantry Assault Robot.

Crew: Three; one pilot and two gunners sitting back to back.

M.D.C. by Location:

- * Searchlights (2, head) – 10 each
- * Upper Leg Mini-Missile Launchers (2) – 30 each
- Shoulder-Mounted Particle Beam Cannons (2) – 120 each
- * Mini-Missile Launchers (2, side of head) – 40 each
- * Forearm Plasma Ejectors (2) – 50 each
- Arms (2, with extra armor plating) – 180 each
- * Hands (2) – 80 each
- Legs (2) – 220 each
- ** Sensor Head – 125
- Reinforced Pilot Compartment – 100
- *** Main Body – 510

* A single asterisk indicates a small and difficult target to strike, requiring the attacker to make a "Called Shot," but even then the attacker is -4 to strike.

** Destroying the head of the robot will eliminate all forms of optical enhancement and sensory systems. The pilot and gunners must rely on their own vision and senses. In addition, all combat bonuses are lost. The head is a comparatively small target protected on the sides, and can only be hit from certain angles and when an opponent makes a "Called Shot," and even then, the attacker is -3 to strike.

*** Depleting the M.D.C. of the main body shuts the vehicle down completely, making it useless.

Speed:

Running: 55 mph (88 km).

Leaping: 10 feet (3 m) high or across, increase by 50% with a running start.

Water: The Buffalo cannot swim, but can walk along the bottom of the sea or lake bed at a speed of 25 mph (40 km). Maximum depth tolerance is 800 feet (244 m).

Flying: Not possible.

Statistical Data:

Height: 25 feet (7.6 m).

Width: 14 feet (4.3 m).

Length: 10 feet (3 m).

Weight: 21 tons.

Physical Strength: Robotic P.S. of 35.

Cargo: There is a small locker built into the pilot compartment large enough to hold a rifle, pistol and survival kit. The Buffalo also features a water filter system with a three gallon (11.3 liter) water tank.

Power System: Nuclear; average energy life is 15 years. Solid Oxide Fuel Cell and electric battery versions are also available.

Cost: Nuclear: 27 million credits for a new or almost new robot with a full weapons load. Solid Oxide: 24 million credits. Electric battery: 22 million credits.

Weapon Systems:

1. Twin Particle Beam Turrets (2; light): Mounted over and above the shoulders are twin particle beam turrets. Each turret can move independent of the other or in tandem for linked fire. Each can rotate 360 degrees and has a 45 degree up and down arc of fire. Each turret has its own gunner, though one gunner is capable of controlling both turrets in linked fire. The pilot handles all other weapons and robot movement. The particle beam cannons are intended to be tank and robot killer weapons, but can also be used to cover the Buffalo from incoming missiles and attackers while it blasts away at other targets with its plasma blasters and mini-missiles. Each particle beam weapon also has a gun camera that functions as an extra set of eyes, and lets the gunner or pilot look behind him/her or keep a watch on the sky. The cameras also come in handy as backup in the event that the cameras and sensor system in the robot's head are knocked out.

Primary Purpose: Anti-Armor and Assault.

Secondary Purpose: Anti-Fortifications and Defense.

Range: 1,600 feet (488 m).

Mega-Damage: 6D6+6 M.D. for a single blast, 2D4x10 M.D. for a dual blast fired simultaneously at the same target.

Rate of Fire: Each single or linked dual blast counts as one melee attack/action.

Payload: Effectively unlimited. 30 dual blasts per charge for electric battery models of the robot.

Bonus: Laser targeting: +1 to strike on aimed shots.

2. Forearm Mounted Plasma Ejectors (2): The Buffalo's forearm weapons give it an additional heavy-hitter punch at a decent range. Point and shoot.

Primary Purpose: Anti-Armor and Assault.

Secondary Purpose: Anti-Personnel and Defense.

Range: 1,600 feet (488).

Mega-Damage: 5D6 M.D. per blast.

Rate of Fire: Each single shot counts as one melee attack; can not fire simultaneously at the same target with both arms.

Payload: Effectively unlimited; tied into the power supply of the robot.

3. Shoulder Mini-Missile Launchers (2): Located in each of the shoulder housings of the particle beam cannons is a mini-missile launcher. The top flips up to launch missiles.

Primary Purpose: Anti-Armor and Assault.

Secondary Purpose: Anti-Personnel and Defense.

Range: About one mile (1.6 km).

Mega-Damage: Varies with missile type. Plasma (1D6x10 M.D.) and Armor Piercing (1D4x10 M.D.) are standard.

Rate of Fire: One at a time or in volleys of 2, 4 or 6.

Payload: 24 total missiles, 12 in each launcher.

4. Leg Mini-Missile Launchers (2): Four mini-missiles can be fired from each of the upper legs. The top flips open and missiles are launched.

Primary Purpose: Anti-Aircraft/Anti-Missile.

Secondary Purpose: Anti-Armor/Anti-Robot.

Range: About 1 mile (1.6 km).

Mega-Damage: Varies with missile type. Any mini-missile can be used, but it comes standard with armor piercing (1D4x10

M.D.) or plasma (1D6x10 M.D.). Fragmentation (5D6 M.D.) may be used for anti-personnel operations.

Rate of Fire: One at a time or in volleys of 2 or 4.

Payload: 8 mini-missiles total, 4 in each upper leg.

5. Handheld Weapons: Giant-sized M.D. Rifles or melee weapons can be used if desired.

6. Hand to Hand Combat: Rather than use a weapon the pilot can engage in Mega-Damage hand to hand combat as per Robot P.S. 35. See *Heavy Ground Robot Training* on page 352 of **Rifts® Ultimate Edition** for the number of attacks per melee and bonuses.

Special Bonus: +2 to parry and +1 to disarm due to the extra plating on the Buffalo's forearms.

7. Sensor System Note: The Buffalo has all the standard robot sensors.

EX-20 Bulldog Explorer

With the immense popularity of the old EX-5 Behemoth Explorer, and the exploding population of settlers, refugees, adventurers and explorers, Northern Gun's robot engineers have decided to develop a number of wilderness exploration robots. Robots that have decent weapons and armor, but are designed for long travels and exploration missions. Robots that can house four or more adventurers and even offer sleeping accommodations. The Bulldog is one such robot.

An instant hit the moment it was released on the market a year and a half ago, the creative minds of **William McGoldrick**, **Charles McComb III**, **Jonathan Lovejoy** and **Donavon Pankrat** are the R&D wizards who brought this robot to life. They went with four legs for maximum stability over uneven terrain, but also included a tracked option for increased speed on open road. To use the tank-like treads, the Bulldog leans back as if standing on its haunches, the legs lock, the treads slide down and lock into place, and the robot is off to the races. The Bulldog is low profile and stands tall enough to tread through deep standing water, marshland and shallow rivers and ponds with ease. The interior compartments are sealed, so the Bulldog can travel underwater, walking along the bottom, but it is not often done. The top-mounted cannon cannot be used underwater unless the gunner has an oxygen supply and suitable armor protection for the depth.

As an explorer robot, there are four small, private, sleeping compartments, a small laboratory and a tiny shower. In addition, the pilot's seat and gunner's seat in the forward rail gun compartment can be made to recline and use as additional sleeping areas, if needed. It is the communal shower that gets much appreciation, as it is a blessing for travelers out in the wild for weeks at a time. There is enough water in the shower for all four crew members to shower. That water is captured, recycled, cleaned and reused as often as 12 times. In addition, there is a small lab room with the most basic of equipment, a half-size refrigerator, and a wall with built-in shelves that hold plastic containers of various sizes that slide in and out, and lock shut, for holding specimens.

In an effort to make the Bulldog an all-purpose vehicle, there is a giant robot hand used for digging, excavation and moving fallen trees and debris out of its path. It can also be used to pull or push heavy loads, stalled vehicles, and for salvage work. The two small robot arms and hands, also located in the front of the

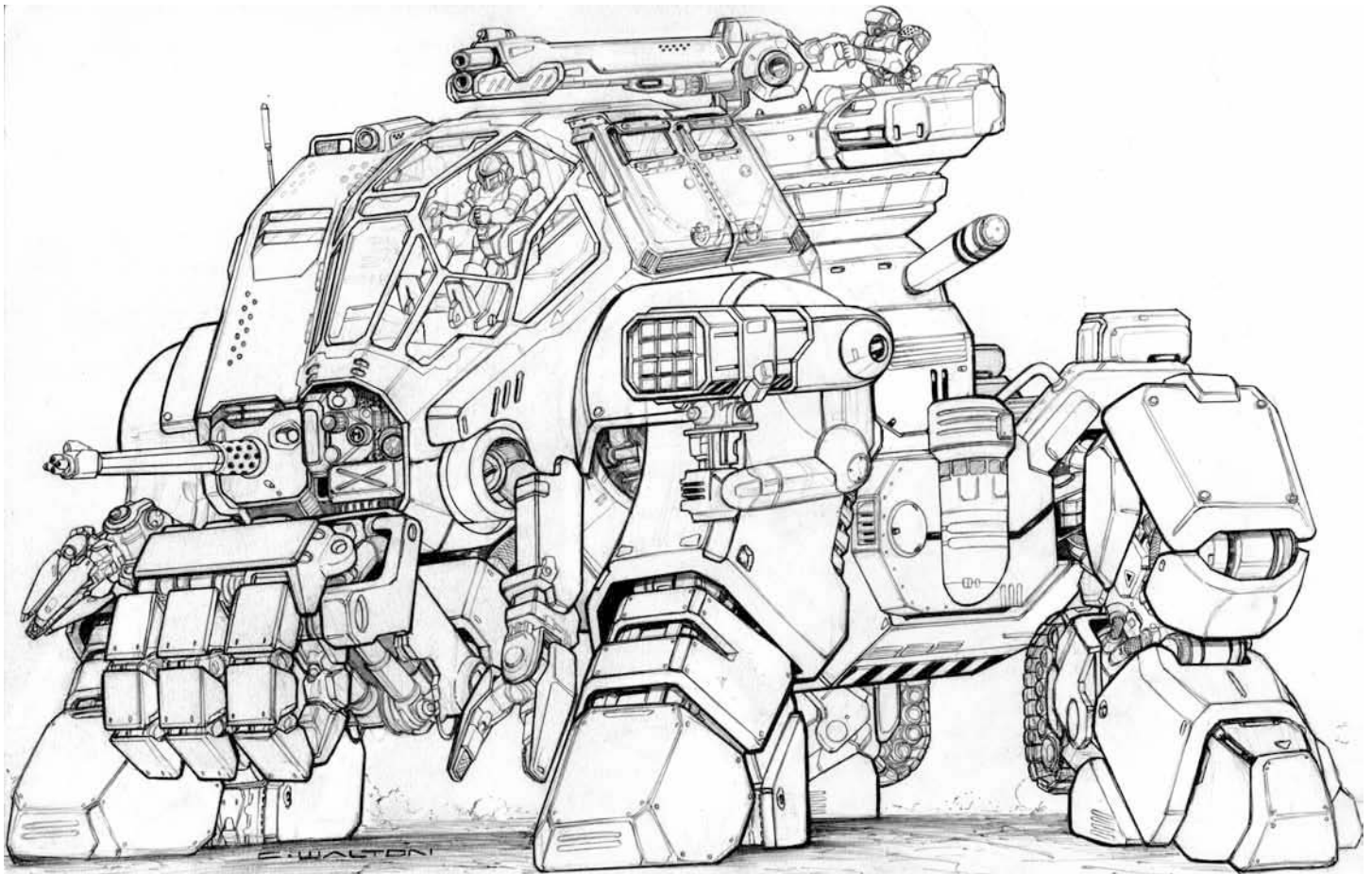

vehicle, are used to gather specimens, tear apart wreckage, gather salvage, make repairs on other robots and vehicles and similar work. The small arms and the large hand can all extend an additional six feet (1.8 m).

Standard weapon systems are the nose gun manned by a dedicated gunner, a missile launcher on the left side, and a big laser cannon in an open-air turret on the top of the Bulldog. The open-air turret is to provide maximum visibility in all directions while exploring. A passenger can sit on a foldout jump-seat to keep the gunner company or to see the sights. The pilot's cockpit is mostly M.D.C. plexiglass windows to provide a comprehensive view of the countryside. The Bulldog comes with snap-on M.D.C. plates that are easy to attach when the team expects trouble. It takes one person about 10 minutes, or two people four minutes to snap the plates over the windows, leaving only a narrow slit. (Small plates have 25 M.D.C., large ones 40 M.D.C.)

Model Type: NG-EX 20

Class: All-Purpose Exploration Robot.

Crew: Three; one pilot, one copilot/gunner, one topside gunner. Can accommodate one additional crew or passenger comfortably, but as many as 4-6 could squeeze in under cramped conditions.

M.D.C. by Location:

- ** Cameras (6, concealed) – 12 each
- ** Lights (8, small, recessed) – 5 each
- Legs (4) – 280 each
- * Arms (2, small) – 75 each
- Giant Hand/Digger (1) – 150
- * Forward Rail Gun (1) – 75
- Rail Gun Armored Gunner's Compartment – 150
- * Pilot's Cockpit (M.D.C. plexiglass) – 100

- * Hatches to Sleeping Compartments (4) – 50 each
- * Exterior Storage Units (3, size of a large cooler) – 25 each
- * Missile Launcher (1, left) – 70
- * Main Gun Turret (1, top) – 170
- ** Tracks (2, back of rear legs) – 50 each
- *** Main Body – 500

* A single asterisk indicates a small and difficult target to strike, requiring the attacker to make a "Called Shot," but even then the attacker is -3 to strike.

** Two asterisks indicates a small and difficult target to strike, requiring the attacker to make a "Called Shot," but with a penalty of -4 to strike.

*** Depleting the M.D.C. of the main body shuts the vehicle down completely, making it useless.

Speed:

Running: 50 mph (80 km) maximum on its feet. Riding on Treads: 70 mph (112 km) on smooth roads.

Leaping: Not possible.

Water: 20 mph (32 km) walking along the soft lake floor. Maximum depth tolerance is 2,000 feet (610 m).

Flying: Not possible.

Statistical Data:

Height: 19 feet, 7 inches (6 m).

Width: 16 feet (4.8 m), from shoulder to shoulder.

Length: 25 feet (7.6 m).

Weight: 24 tons.

Robot Strength: Generally, P.S. 40; small arms: 28.

Cargo: The Bulldog's storage bay is the size of a 6x4x4 foot (1.8x1.2x1.2 m) closet, plus three 4x2x2 foot (1.2x0.6x0.6 m) exterior lockers. The pilot cockpit and forward gunner have enough

space to stow an extra suit of body armor, survival kit, first-aid kit, 5 gallons (19 liters) of water, and a backpack. Additional crates and packages can be tied to the exterior of the robot.

Power System: Nuclear; average energy life is 20 years. Solid Oxide Fuel Cell and electric battery versions are also available.

Cost: 31 million credits nuclear, 27 million Solid Oxide, 23 million electric battery.

Weapon Systems:

1. Main Gun Turret (1): The main gun on top of the Bulldog is a double-barreled, dual weapon system. The top barrel is a long-range laser, the lower one is an ion cannon with shorter range but more firepower. The entire turret can rotate 360 degrees and has a 45 degree up and down arc of fire when turned to the sides or the back; 30 degree when pointed forward over the cockpit.

Primary Purpose: Defense and Anti-Monster.

Secondary Purpose: Anti-Armor and Anti-Flyers.

Range: Laser: 3,000 feet (914 m). Ion Cannon: 1,200 feet (366); half those ranges underwater.

Mega-Damage: Laser: 3D6 M.D. per blast. Ion Cannon: 5D6 M.D. per blast. 1D4x10+4 per simultaneous dual blast at the same target, provided it is within range of both guns.

Rate of Fire: Each single or dual blast counts as one melee attack.

Payload: Effectively unlimited.

2. NG-501 Rail Gun: The nose gun is an NG-501 Rail Gun. It faces forward but can be moved 20 degrees in any direction and has a good payload. A dedicated gunner mans this weapon system.

Primary Purpose: Defense and Anti-Armor.

Secondary Purpose: Anti-Personnel.

Range: 4,000 feet (1,219 m).

Mega-Damage: A burst is 40 rounds and inflicts 1D4x10 M.D.; can substitute with special anti-supernatural rounds (see Gunwolf).

Rate of Fire: Each burst counts as one melee attack/action.

Payload: 3,680 rounds for a total of 92 bursts; 1,840 rounds or 46 bursts in each of the two detachable drum magazines (accessed from the sides).

3. Side-Mounted Mini-Missile Turret (1): Mounted on a swivel arm that can rotate 180 degrees and has a 45 degree up and down arc. **Note:** The mini-missile launcher is standard, but for an extra 500,000 credits, it can be substituted with a short-range missile launcher.

Primary Purpose: Defense and Anti-Monster.

Secondary Purpose: Anti-Armor and Anti-Missile.

Range: Varies with type.

Mega-Damage: Varies with type. Standard launcher and payload is mini-missiles. Any type of mini-missile can be used, but standard issue is a mix of 60% High Explosive (1D4x10 M.D.), 30% plasma (1D6x10 M.D.) and 10% smoke.

Rate of Fire: One at a time or in volleys of two, four or six. Firing a single mini-missile or a volley counts as one melee attack.

Payload: Varies with the type of missile. Mini-Missiles: 36 total. Short-Range Missiles: 12 total.

4. Hand to Hand Combat: Rather than use a weapon, the pilot can engage in Mega-Damage hand to hand combat. However, the Bulldog is not designed for combat, so it gets half the number of attacks when fighting hand to hand, and also reduce the

bonuses described for *Heavy Ground Robot Training* on page 352 of **Rifts® Ultimate Edition** by half. Robot P.S. 40 for the large arm, Robot P.S. 28 for the small ones.

Giant Hand/Digger – 2D6+3 M.D. for a full strength punch and tear or pry. 1D6 M.D. crush. Power Punch is not possible. Small, Retractable Arms (2) – 1D6 M.D. punch and tear. Power Punch is not possible. The small arms can extend an additional six feet (1.8 m) and have a light and a camera.

Other Close Combat Attacks:

Stomp or Trample – 2D6+2 M.D.

Body Block – 2D6 M.D. with a 01-66% likelihood of knocking down opponents of equal size or smaller. Victims of knockdown lose initiative and one melee attack.

5. Sensor System Note: Has all basic robot systems.

Gunbot Robot-Killer

The Gunbot is a mobile weapons platform loaded down with more guns and firepower than armor. It is an anti-armor/anti-monster, “robot-hunter” like the tank-hunters of old, and the brainchild of lead designers **Mike Sykes, Chris Steinbrenner** and **Richard J. Perez**. In this case, it is a low-profile, bipedal walking cannon made for ambushing and engaging larger, more heavily armored opponents and holding defensive positions. Though designed for robot to robot combat, the Gunbot performs admirably against living, armored juggernauts such as Fury Beetles, Dinosaurs, dragons and monsters. The Gunbot’s armaments can deliver devastating attacks to such armored opponents, but to avoid taking damage itself, the pilot must rely on the speed and mobility of the Gunbot to escape enemy fire. To this end, the robot’s ability to run, leap, crouch down low, and pop up to fire goes a long way. Jet thrusters in the back of the lower legs, and a trio of jets in the back of the main body, enable the pilot to make jet-assisted leaps that would seem otherwise impossible for a robot this size. A dozen strategically placed stabilizing thrusters in the undercarriage of the main body, and elsewhere, help provide balance. Running and leaping, and bobbing and weaving makes the Gunbot Robot-Killer a truly difficult target to hit. (**Note:** All attackers are -1 to strike in general and -2 to strike on *Called Shots* whenever the Gunbot is in motion.)

This motion defense system is something new and experimental, developed by the design team of Walton, Clements, Martin and Beedah. It can take some getting used to, but once the pilot and gunners get the hang of it, the bounding and blasting Gunbot can become a blur of motion and destruction without peer. Initial market acceptance has been slow, but mercenaries and adventurers are starting to come around to the idea, and Northern Gun uses the robot in its own defenses and “hunting” missions.

In the field, a common strategy is to have the Gunbot Robot-Killer take a strategic position behind cover (trees, debris, etc.), or under camouflage netting, and lie in wait. When an armored target appears, the Gunbot makes the first attack from its concealed location, like a sniper, often unleashing rapid-fire from multiple weapon systems (i.e., rail gun, ion cannon and missile volley), before the target knows what hit it, or from where. A moment later, the Gunbot abandons its “sniper” position and begins to move, leaping and running, bobbing and weaving behind other cover or new firing positions, or moving up, fast, on the enemy for the kill shot or additional attacks on other armored units. In

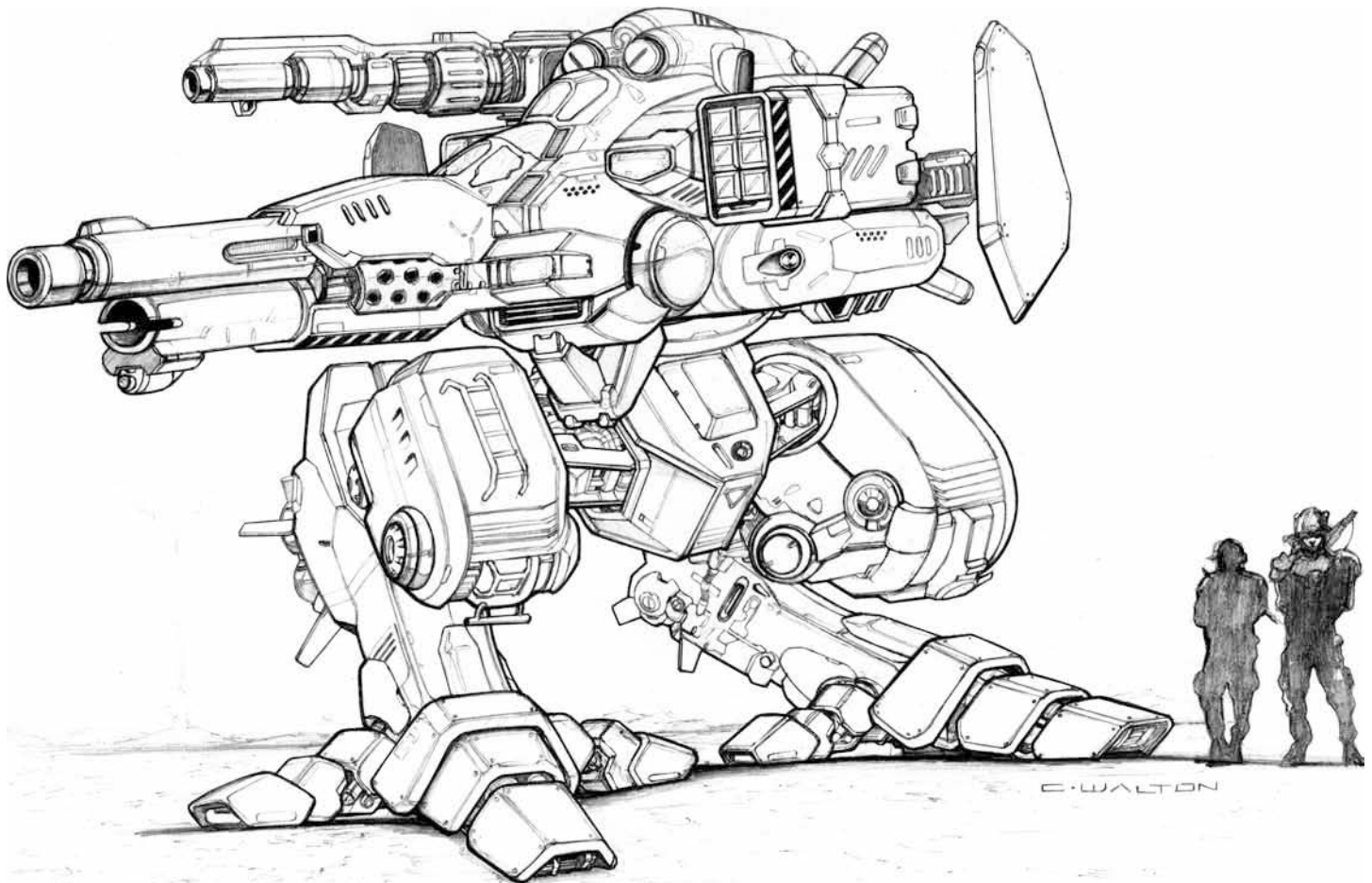

the alternative, the Gunbot may choose to hit and run – fleeing the area entirely or leading the pursuing enemy into an ambush.

Gunbot Robot-Killers may also be used in perimeter defense of towns, lookout posts, and military base camps. In this case, the robot is used as a mobile weapon turret and may even rest inside a bunker or behind a defensive wall or barrier made of debris, with only its guns and upper body showing. As enemies or hostile intruders move in, the robot functions as a sort of bunker turret blasting away with its weapon systems, while its lower torso and legs are protected by the bunker walls. However, there is never a roof to such a “bunker” arrangement, enabling the Gunbot to leap up and out from behind the defensive walls to pursue enemy targets or take up a new, superior defensive position as the battle progresses. Enemies not familiar with the Gunbot Robot-Killer are surprised when the bunker turret leaps out to reveal it is a mobile combat robot. It is this mobility that makes the Gunbot a versatile field and defense robot.

Its main weakness is its lack of heavy armor. Northern Gun does not have the same advanced M.D.C. alloys, nor propulsion systems and avionics as the CS and Triax, so the Gunbot trades armor to make it light enough to take advantage of its jump-jet system. The Gunbot is too heavy and ungainly to actually fly, but can certainly surprise opponents with its jumping abilities and speed.

Enemy targets unfortunate enough to step into the Gunbot’s sights will come under fire from its main gun: a heavy ion cannon and rail gun combined weapon system. Mini-missiles and a grenade launcher complete the package, giving the Gunbot a nice range of different weapons capable of taking out armored opponents such as other giant robots, tanks, and Mega-Damage

monsters as well as infantry troops. The variety of weapons also gives the Gunbot combat options with varying effects and range. Many mercenaries and even NG salespeople often refer to the Gunbot as both a “Robot/Tank-Killer” and a “Dragon Slayer.”

Model Type: NG-V47 Gunbot Light Artillery.

Class: Infantry Assault and Support Robot.

Crew: One pilot and two gunners.

M.D.C. by Location:

Legs (2) – 250 each

* Feet (2) – 145 each

** Pilot’s Cockpit (1, upper) – 120

** Gunners’ Cockpit (1, lower) – 140

* Grenade Cannon (1, right side; top) – 115

* Nose Gun: Rail Gun (1, upper barrel) – 150

* Nose Gun: Ion Cannon (1, lower barrel) – 135

* Mini-Missile Box Launchers (2, right and left side) – 50 each

* Maneuvering Thrusters (12, small, mostly undercarriage) – 5 each

* Leg Jump-Jet Clusters (2) – 35 each

Rear Jet Thrusters (3, back of main body) – 40 each

Shield Panels (2, behind Box Launchers) – 90 each

*** Main Body (upper half above the legs) – 390

* A single asterisk indicates a small and difficult target to strike, requiring the attacker to make a “Called Shot,” but even then the attacker is -3 to strike; even more difficult (an additional -2) when the Gunbot is moving and leaping.

** Two asterisks indicates a small or difficult target to strike, requiring the attacker to make a “Called Shot,” but even



then he is -4 to strike; even more difficult (an additional -2) when the Gunbot is moving.

*** Depleting the M.D.C. of the main body shuts the vehicle down completely, making it useless.

Speed:

Running: 75 mph (120 km). Power jumping and high-speed bounding and running: 105 mph (168 km).

Leaping: The robot's powerful legs and jet boosters enable it to perform leaps and running-leaping movements. *Leaps without jets:* 30 feet (9.1 m) high or across, double at speeds of 50 mph (80 km) or greater. *Jet-assisted leaps:* 50 feet (15.2 m) high and up to 100 feet (30.5 m) across, double at speeds of 50 mph (80 km) or greater.

Water: The Gunbot cannot swim, but can walk along the bottom of lakes and seas at a maximum speed of 30 mph (48 km). Maximum depth tolerance is 2,000 feet (610 m).

Flying: Not possible.

Statistical Data:

Height: 18 feet, 10 inches (5.8 m).

Width: 12 feet (3.6 m) at the hips. The low-profile upper torso/gun turret main body is long and narrow; 9 feet (2.7 m) from box launcher to box launcher, 11 feet (3.3 m) with shields fully extended.

Length: 18 feet (5.5 m).

Weight: 12 tons for the robot, plus 3.2 tons fully loaded with ammo and missiles.

Physical Strength: Equal to a Robotic P.S. 35.

Cargo: Minimal, a small locker with enough room for a rifle, pistol, survival kit, 10 gallons (37.9 liters) of water and a few personal items.

Power System: Nuclear; average energy life is 15 years. Solid Oxide Fuel Cell and electric battery versions with a 5.6 year life are also available.

Cost: Nuclear: 31 million credits. Solid Oxide: 24 million credits. Electric Battery: 21 million credits. Good availability.

Weapon Systems:

Note: The pilot and two dedicated gunners sit in two separate cockpits. The pilot in the upper cockpit handles all the movement, running and leaping. The lower cockpit contains two gunners. One handles the dual nose guns, the other fires the mini-missiles and grenade cannon. All coordinate their actions with each other. To point the main guns (numbers 1a & 1b), the entire upper torso of the Gunbot must turn and aim like the turret of a tank.

1. Dual-Cannon Nose Guns: The Nose Guns are the Gunbot's main guns. Both are built into the same fixed-forward housing, but the upper body of the Gunbot can rotate 360 degrees to fire in any direction, and can tilt up and down 45 degrees, giving it a good arc of fire effective against ground troops and low flyers. **Linked Fire Note:** When an enemy target comes within range of both the rail gun and the ion cannon (1,800 feet/548.6 m), they can both be unleashed to inflict simultaneous damage upon the same target. That's 2D4x10 M.D. per dual melee attack.

a) NG-1010 Heavy Rail Gun: The Gunbot's primary weapon is an NG-1010 Rail Gun with an underbarrel ion cannon built in. The rail gun has superior range and fires hard shells that cannot be mitigated by energy-reflecting armor or magic. A dedicated gunner mans this dual weapon system.

Primary Purpose: Anti-Armor and Anti-Monster.

Secondary Purpose: Anti-Aircraft and Anti-Flyers.

Range: 5,000 feet (1,524 m).

Mega-Damage: A burst is 40 rounds and inflicts 1D4x10 M.D.

Rate of Fire: Each burst counts as one melee attack/action. See linked fire, above.

Payload: 3,680 rounds for a total of 92 bursts; 1,840 rounds or 46 bursts in each of two detachable drum magazines (accessed from the sides).

b) NG 2020 Underbarrel Ion Cannon: Beneath the heavy rail gun barrel is a high-powered ion cannon. The weapon has good range for an NG ion weapon, does impressive damage and should not be used carelessly. A dedicated gunner mans this dual weapon system.

Primary Purpose: Assault and Anti-Infantry.

Secondary Purpose: Anti-Armor and Anti-Monster.

Range: 1,800 feet (548.6 m).

Mega-Damage: 1D4x10+4 M.D. per single blast.

Rate of Fire: Each blast counts as one melee attack/action. See linked fire, above.

Payload: Effectively unlimited.

2. Shoulder Mini-Missile Launchers (2): Each of the robot's shoulders sports a series of six mini-missile tubes. The mini-missiles can be used for extra long-range attacks, to shoot down aircraft, or simply as bombardment weapons. The mini-missile launchers can tilt out 25 degrees and rotate 360 degrees to fire forward, upward and behind the robot. The second gunner or pilot operates the mini-missile launchers.

Primary Purpose: Anti-Armor.

Secondary Purpose: Anti-Aircraft/Flyers.

Range: About one mile (1.6 km).

Mega-Damage: Varies with missile type.

Rate of Fire: One at a time or in volleys of two, three or six.

Payload: 24 total; 12 per box launcher.

3. NG-GL1030A Grenade Cannon (1, top): Mounted atop the robot's right side is a rapid-fire grenade launcher that looks more like a cannon. Its longer barrel and cannon-like design provides it with better range. The grenade cannon is used to suppress enemy infantry, punch holes in defenses, knock out bunkers and fortified positions and create cover. Able to point from the front to the back, the gunner can position the weapon to defend itself along its entire right side as well as fire at enemies behind it. The grenade launcher can sweep from front to back, 220 degrees and has a 90 degree up and down arc of fire. The second gunner operates this weapon.

Primary Purpose: Assault and Anti-Personnel.

Secondary Purpose: Anti-Monster and Riot Control.

Range: 1,800 feet (548.6 m).

Mega-Damage: 3D6 M.D. per single grenade to a 12 foot (3.7 m) radius for fragmentation grenades (1D4x10+3 M.D. for a 3-grenade volley), 4D6 M.D. to a 3 foot (0.9 m) radius for high explosive/armor piercing grenades (1D6x10+6 M.D. for a volley of three), or 6D6 M.D. to a five foot (1.5 m) radius for a single plasma grenade (2D4x10+12 M.D. for a volley of three). **Note:** As a rapid-fire weapon, the cannon can fire one grenade at a time or a rapid-fire volley of three (unleashed a split second apart). A volley always contains the same type of grenade.

A *smoke grenade* covers a 40 foot (12.2 m) radius in a dense cloud of smoke, obscuring vision and creating cover. Radius x3 for a volley of three smoke grenades, tear gas or flash grenades.

A *tear gas grenade* covers a 25 foot (7.6 m) radius and makes the eyes and noses of victims not protected by gas masks or environmental armor burn and tear, as well as gags and chokes them (-10 to strike, parry, dodge, -3 on initiative and lose one melee attack as long as they are in the gas cloud and for 1D6+1 melee rounds after exiting it; protected individuals suffer no penalties).

A *stun/flash grenade* unleashes a bright flash, sparkles and white smoke that temporarily blind victims (-10 to strike, parry, and dodge, -1 on initiative, and lose one melee attack for 1D4 melee rounds). Radius of effect is 4 feet (1.2 m).

Rate of Fire: Single shot or volley of three. Each shot or volley counts as one melee action/attack.

Payload: 120 grenade drum for a total of 40 volleys. Can be all one type of rifle grenade or a “mixed load” of 2-5 different types. A Riot Control payload contains only non-lethal grenades: Tear Gas, Stun/Flash and Smoke.

4. Hand to Hand Combat: When necessary, the pilot can engage in Mega-Damage hand to hand combat. However, the Gunbot has no arms and is limited to swats with its gun nose, kicks, stomps and ramming attacks. See *Light Ground Robot Training* on page 353 of **Rifts® Ultimate Edition** for combat bonuses. **Note:** Cannot parry, punch or power punch. Robot P.S. 35.

Swat with Gun Barrels of the Nose – 2D4 M.D.

Kick Attack – 2D8+4 M.D.

Leap Kick Attack – 4D8+8 M.D., but counts as two attacks.

Power Leap Kick (Jet Thruster Boosted) – 1D4x10+12, but counts as three attacks and requires a running start.

Stomp or Trample – 2D4 M.D., but limited to targets 6 feet (1.8 m) tall or smaller.

Leaping Stomp – 1D6x10+12 M.D., but counts as three attacks and is -2 to strike. This attack requires the Gunbot to leap up and land on top of the target to stomp it. Maximum leaping height is 30 feet (9.1 m) without jet assistance; 60 feet (18.3 m) with a running start at speeds of 50 mph (80 km) or greater. *Jet-assisted leaps:* 50 feet (15.2 m) from a standing still position, or 100 feet (30.5 m) with a running start at speeds of 50 mph (80 km) or greater.

Body Block/Ram – 2D6 M.D. with a 01-66% likelihood of knocking down opponents of equal size or smaller (+1D6 M.D. at maximum speed and +1D6% to knockdown). Victims of knockdown lose initiative and one melee attack.

5. Sensor System Note: The Gunbot has all the standard robot systems.

Gunwolf

The Gunwolf was created to fill a gap in NG’s robot product line: A monster fighter. A robot capable of standing against waves or swarms of demons and monsters, or giant horrors like dragons, as well as able to engage robots, power armor and conventional troops. With the alarming increase of the Xiticix population, and the frequent appearance of new demons and monsters, as well as alien monstrosities from beyond the Rifts all on the rise, NG execs were concerned. It seems only a matter of time before Ishpeming, or another nation, might have to fight an entire *army* of monsters. Such events were certainly not unprecedented. People still tell stories about the Demon Plagues of the Two Hundred Years Dark Age, a nightmare that Northern Gun itself had managed to survive, barely. The *Tolkeenites* raised armies of Daemonix, Brodkil and other supernatural beings to throw at the invading Coalition Army; and the *New German Republic (NGR)* is famously surrounded by millions of hostile Gargoyles and Brodkil, and have battled them for generations. With more and more chatter in recent years about the Vampire Kingdoms in Mexico and a new Kingdom of Monsters in Calgary, Canada, not to mention a seemingly growing number of demonic beings and dinosaurs being flushed out from the North and West, there is definitely a market for an anti-monster robot.

Since Northern Gun survived the Two Hundred Years Dark Age and has hundreds of mercs, Psi-Stalkers and “specialists” under contract who have experience battling such monstrosities, the nation *is* prepared to deal with supernatural invaders. Probably more so than some other nations. After all, NG has a reserve of silver weapons and ammo, as well as some magic items and strategies and tactics to deal with such an event. They also make and sell silver weapons and ammo to vampire hunters, demon slayers, mercs and adventurers across the continent, but all are for small-scale combat operations. There are no heavy, combat robots or preparations for a mass onslaught like generations past. As further evidence of this tactical mistake, NG executives point to kingdoms of magic, all of whom have magical weapons and war machines to deal with such threats. This concern has led to the creation of the Gunwolf anti-monster combat robot.

The lead designers of the Gunwolf, **Charles Walton, John Kallil, Marc Ferrari** and **Andrew Kelsoe**, spent hundreds of hours researching the supernatural threat in order to design a robot that would have maximum effectiveness against a wide range of inhuman foes. The end result is a heavily armored and versatile combat robot, equipped to fight creatures of magic and the supernatural, as well as high-tech enemies. To set the robot apart and include more combat features, the team gave it a stylized, mechanical wolf’s head and a biting maw lined with silver-plated teeth, and powerful, crushing jaws.

Projectile weapons generally being the most effective against the supernatural, provided the rounds are coated in silver, made of wood, or some other unconventional ordnance, the Gunwolf has several such weapons. A pair of dual rotary rail guns are mounted on the right forearm. One is loaded with silver rounds, the other firing specially designed wood and silver rounds. Located in the nose of the cockpit, in the center of the chest, is a lighter rail gun also capable of firing conventional or anti-monster ammo. Mounted under it is a secondary sensor cluster with two cameras (one conventional, one infrared), an infrared spotlight plus the



usual array of sensors. A pair of concealed, gun-style mini-missile launchers provide explosive power. Plasma missiles are the standard payload for use against monsters and animals vulnerable to fire. In addition, each hand has large, silver-plated claws for slashing in close combat, but also suitable for climbing, digging, mining, salvage operations and ripping through enemy defenses.

Keeping in mind the need to have weapons that can dish out damage to human opposition and ordinary monsters (not just magical or supernatural beings), a heavy ion cannon is mounted on the left forearm and lasers fire from the eyes. The ion cannon and lasers are effective against fellow mortals, armored vehicles, dinosaurs and other dangerous animals, as well as the terrestrial servants and henchmen of demons and monsters. Of course, a silver-plated rail gun slug will chew up mortal troops as nicely as the supernatural, but the design team wanted to insure there were weapons sufficient to deal with a wide range of enemies.

The designers understood that most monstrous animals and many demonic beings fight like predatory animals. That means they like to pounce and attack with tooth and claw in close combat. This is where the Gunwolf is at its greatest advantage. The biting maw and massive silver claws are equal to those of any monster, but there is more thought to them than that. The Gunwolf pilot will deliberately bait demons and monsters to charge and pounce. When the beast gets in close, the pilot grapples and holds the creature, the robot's claws digging deep into the monster's flesh. Better yet, the tooth-filled mouth bites into the monster's neck or shoulder, or one of its limbs, and holds tight. With the monster held by the maw or claws, or the creature willingly engaged in hand to hand combat, the pilot can fire the chest gun while a gunner blasts with the laser eyes and/or the flamethrower. Likewise, the mini-missiles can be fired right into the giant monster, and if the pilot or gunner has the angle, the robot can blast away at point-blank range with either of the forearm weapons. This strategy and tactic may sound unfair and brutal overkill, but fighting such creatures is no game, and a quick kill is the best possible result.

Northern Gun has recently added a significant number of these anti-monsters to their own military reserve. They have also been assigned to a select number of border patrol operations and excursions into hostile wilderness to hunt monsters and to put the relatively new robot through its paces in the field. To support Gunwolf patrols, a few other fast robots or power armor may be deployed with them. A small, standard **Gunwolf patrol** consists of 1D4+2 Gunwolves and two fast, smallish robots or 3-4 power armor troops. Larger deployments may consist of an *entire squad* of 8-10 Gunwolves and 2 other robots or 2-4 power armor troops. Such squads have come to be known as the **Northern Wolves**. Meanwhile, an entire platoon of 14-20 Gunwolves, 2-4 other robots plus 2-8 power armor troops are known as a **Wolf Pack**. While the smaller, accompanying robots and power armor units provide support, they more often fill the role of *hounds* to flush predatory monsters out in the open or toward the Gunwolf where it lays in wait.

Results with the Gunwolf have been impressive and intimidating, making it popular among bounty hunters, monster hunters, mercenaries and city-states who have issues with monsters or demons and the supernatural. Having only been released in the last year, the Gunwolf has not yet made it into the American Southwest or Mexico to fight vampires.

There are two notable weaknesses to overcome with the Gunwolf. One is the robot's reliance upon weapon systems with finite ammunition. When the ammo is gone, the Gunwolf crew must rely upon hand to hand combat and energy weapons, of which the latter *may* be completely ineffective against many supernatural and magical foes. Similarly, after the ammo is gone, the Gunwolf can be overwhelmed by swarming monsters like the *Xiticix*, though the robot has proven fairly effective inside hive tunnels. The trick in fighting *Xiticix* is either going in with a force that can completely wipe out all members of the hive, or getting out alive and making a hasty retreat. Of course, that's true of all hive incursions with any vehicle or troops. This is why hit and run strikes with a transport vehicle close at hand (or a means of magical extraction or concealment) are the only way attackers invading a *Xiticix* hive have any chance of survival. Once a *Xiticix* hive is riled up, the frenzied insectoids don't stop searching and killing until all intruders are destroyed, or have fled further than two miles (3.2 km) from the hive. In some rare cases, soldiers have managed to hide and slip away hours later. Many Gunwolf pilots believe a large robot and power armor force led by a company of Gunwolves could march on a hive, enter and wipe out the entire hive population. There are even some Gunwolf pilots lobbying to give it a try, knowing full well that it could be a suicide mission. So far, no human power has tried such an operation even against a small hive.

The second problem is the Gunwolf's bulk and overall design. The irony is the Gunwolf was originally conceived as a sleek, fast robot able to prowl the woods in search of monsters, as if it were a robotic predator. However, the developers quickly moved away from that idea in favor of projectile weapons with massive payloads, heavy armor and enough mass to wrestle with dragons, demons and giants. Probably the right move, as the smaller, sleeker early prototypes would run out of ammo after two or three kills and were easily tossed around by giant monsters.

The final version of the Gunwolf is ideal for stand-up fights, holding a perimeter position, urban combat and fighting in confined spaces as well as out in the open. It is, however, terrible as a stealthy, woodland hunter. Not only does its size and bulk work against it, but almost every weapon and design element seems to be made to snag on branches, brush and vines. Walking even through a light forest, the robot can be heard for a mile (1.6 km) as it crashes through trees and rips down branches that get caught in the spikes and barrels of its weapon systems and other protruding elements of the big, heavy robot.

Otherwise, the design is tough, durable and reliable under the worst of conditions.

Model Type: NG-V61 Gunwolf.

Class: Anti-Monster and Infantry Combat Robot.

Crew: Two; one pilot and one copilot/communications engineer.

M.D.C. by Location:

- * Wolf's Howl Fins (4, back, right side) – 60 each
- * Wolf's Howl Transmitter Array (1, top right) – 50
- * Searchlight Array (1, left, back) – 50
- * Secondary Sensor Turret (center) – 25
- Searchlight Extendible Limb (1, behind left shoulder) – 50
- Shoulder Plating (2, top, heavy) – 200 each
- Arms (2) – 170 each
- Hands/Claws (2) – 100 each
- * Forearm Rail Guns (2, right arm) – 75 each
- * Forearm Ion Cannon (1, left arm) – 50

- * Chest Rail Gun – 50
- Legs (2) – 220 each
- * Retractable Mini-Missile Launchers (2) – 50 each
- * Neck – 130
- ** Eye Lasers (2, one per socket) – 15 each
- Head & Main Sensor System – 180
- Reinforced Pilot Compartment – 100
- *** Main Body – 480

* A single asterisk indicates a small and difficult target to strike, requiring the attacker to make a “Called Shot,” but even then the attacker is -3 to strike.

** Two asterisks indicates a smaller or more difficult target to strike, requiring the attacker to make a “Called Shot” with a penalty of -5 to strike.

*** Depleting the M.D.C. of the main body shuts the vehicle down completely, making it useless.

Speed:

Running: 60 mph (96 km), a good speed for a robot so heavily armored and laden with heavy ordnance.

Leaping: Due to the heavy armor and bulk, the powerful robot legs, even with jet stabilizers in the legs, can only leap 10 feet (3 m) high and 18 feet (5.5 m) across with a running start.

Water: The Gunwolf is not designed for use in water, but can walk along the bottom at 25 mph (40 km) at maximum speed. Maximum depth is 1,200 feet (366 m).

Flying: Not applicable.

Statistical Data:

Height: 26 feet (7.9 m).

Width: 20 feet (6 m), at the shoulders.

Length: 14 feet (4.2 m).

Weight: 30 tons, fully loaded.

Physical Strength: Equal to a Robotic P.S. 40.

Cargo: Minimal, several medium lockers (1 on each thigh and pelvis bay), 2 small lockers on the knees and one mid-large locker in the back unit. Each has 50 M.D.C.

Power System: Nuclear, average energy life is 20 years. Solid Oxide Fuel Cell and electric battery versions are also available.

Cost: Nuclear: 38 million credits. Solid Oxide: 34 million credits. Electric Battery: 31 million credits.

Weapon Systems:

1. Dual NG-232 Rail Guns: These big guns are mounted on the right forearm of the robot, and are bigger than even many vehicle-mounted weapons. Opponents who underestimate the Gunwolf’s range capabilities by focusing only on the Gunwolf’s jaws and talons are often struck from afar by a surprise burst of nasty rail gun rounds.

Primary Purpose: Assault & Anti-Personnel.

Secondary Purpose: Defense.

Range: Conventional rail gun rounds and silver coated rounds: 4,000 feet (1,219 m). Special, weighted wood rounds with silver rings: 2,000 feet (610 m).

Mega-Damage: Varies. **Standard & Silver Ammo:** A standard M.D. burst is 60 rounds and inflicts 1D4x10 M.D.; one round does 1D4 M.D.; 2D4x10 M.D. for a dual burst in linked fire at the same target (counts as one melee attack).

Special Ammo Rounds: Depending on what the Gunwolf is hunting or expects to encounter, the robot is likely to carry different types of rounds. There are silver-plated slugs for creatures

like werebeasts vulnerable to silver, and wooden rounds with silver rings to use against creatures, like vampires, vulnerable to wood and silver. The addition of silver rings means the rounds are suitable for use against creatures vulnerable to either wood or silver. **For example,** if the creature is impervious to wood, a shaft of wood/wood rounds would harmlessly pass through or shatter on impact with its body, but if vulnerable to silver, when that part of the round hits, the creature takes full damage. And vice versa. These are S.D.C. rounds that do 1D4 S.D.C., 1D4x10 S.D.C. or 2D4x10 S.D.C. for a dual, simultaneous blast.

Rate of Fire: Each single shot or burst counts as one melee attack. **Payload:** 18,000 rounds total. Four 2,250 round drums (9,000 total rounds), two for each rail gun, with enough ammo for 150 bursts for each Gatling-gun style rail gun (300 bursts total). **Note:** As a general rule, one rail gun has a payload of M.D.C., silver-coated rounds (does M.D.C. equivalent damage as Hit Point/S.D.C. damage to supernatural creatures vulnerable to such things) and one with the special wood and silver rounds (150 bursts for each type).

Reloading a Gunwolf’s rail gun requires loaded ammo drums being available and special equipment or another giant-sized robot and a readily available ammo drum. It will take about 15 minutes for those not trained, but a mere five minutes by somebody trained in Robot Mechanics or who is an Operator.

Rail Gun Weapon Blades: Even when the ammo is spent, the barrel tips are lined with short, silver-plated blades for slashing and stabbing; does 2D4 M.D. per attack.

2. Medium NG-223 Chest Rail Gun (1): A medium rail gun is built into the chest and used against closer targets and on opponents while grappling or locked in hand to hand combat. Like the other rail guns, it can fire conventional rail gun rounds, conventional silver-coated rounds or special wood and silver rounds.

Primary Purpose: Assault & Anti-Personnel.

Secondary Purpose: Defense.

Range: Conventional rail gun rounds and silver coated rounds: 2,000 feet (610 m). Special, weighted wood rounds with silver rings: 1,000 feet (305 m).

Mega-Damage: Varies. **Standard & Silver ammo:** A standard M.D. burst is 60 rounds and inflicts 5D6 M.D. (+4 M.D. to opponents at point-blank range; within 10 feet/3 m) for a burst. One round does 1-2 M.D.

Special Ammo Rounds: Same. These are S.D.C. rounds that do two S.D.C. per round and 5D6 S.D.C. per burst.

Rate of Fire: Each single shot or burst counts as one melee attack.

Payload: 9,000 rounds total, enough ammo for 150 bursts.

3. NG-I-323 Ion Cannon (1): Mounted on the left forearm is a medium ion pulse cannon. The cannon is hardwired into the robot’s nuclear power supply for ammo and provides decent firepower and reliability. For use against opponents vulnerable to energy attacks.

Primary Purpose: Anti-Armor.

Secondary Purpose: Assault.

Range: 1,600 feet (488 m).

Mega-Damage: 5D6 M.D. per blast.

Rate of Fire: Each blast counts as one melee attack/action.

Payload: Effectively unlimited. 50 blasts per charge for the electric battery models.

4. Retractable Mini-Missile Launcher (2): Housed in the lower sides of the chest chambers are retractable mini-missile launchers.

Primary Purpose: Anti-Aircraft, Anti-Missile and Anti-Flyers.

Secondary Purpose: Anti-Personnel/Monsters and Anti-Armor.

Range: One mile (1.6 km).

Mega-Damage: Varies by missile type, but *plasma (1D6x10 M.D.)* for use against creatures vulnerable to fire, is standard.

Rate of Fire: One at a time or in volleys of two, four or six.

Payload: 28 total, 14 per launcher. Must retract to reload, after its payload of 7 has been fired. It takes one melee round (15 seconds) for the automatic reload.

5. Wolf's Head Weapon Platform: The robot's head is a multi-weapon platform and sensor unit (see sensor details in #9), with eye lasers, fire-breathing, and bite attacks.

The design and mechanics of the Gunwolf's head are particularly noteworthy. It is both the main sensor array and a multi-weapon system, with the pilot and crew seated inside the robot's chest, not the head. The large front teeth are silver-plated, as are the rest of the smaller teeth. The powerful jaws are capable of biting and tearing through M.D.C. hides and armor. Inside the mouth is a flamethrower to use against animals and monsters afraid of, or vulnerable to, fire. The sight of a fire-breathing, wolf's headed robot is also a startling and frightening image and has been shown to have an effect even on lesser demons. The eye housings contain a battery of optic systems, as well as a pair of light lasers. The sensors are located in the top of the head. Mounted on the back is the Wolf's Howl, an ultrasonic attack that disorients many animals and supernatural targets.

a) Assault Jaws: The robot's deadly hydraulic jaws can exert a bite that can penetrate M.D.C. hides and steel, snag flying power armor and bite or latch onto monsters and robots in hand to hand combat.

Primary Purpose: Assault.

Secondary Purpose: Defense.

Mega-Damage from Bite:

Controlled "Soft" Bite/Nip – 1D4 M.D.

Full Strength Bite – 2D6+3 M.D.

Power Bite – 4D6+6 M.D.

Power Bite & Lock-Grip – 4D6+6 M.D. from the initial power bite, plus a 01-50% chance of holding on to its opponent in its teeth. This enables the Gunwolf to hold on with its locked jaws and deliver an additional 2D6 M.D. by shaking its head violently. Each shake counts as one melee attack, does 2D6 M.D. and does not require a roll to strike because the Gunwolf is latched onto its prey with its teeth and powerful jaws. To pull free, an opponent must roll 18 or higher to parry and pull free, but takes 3D6 M.D. in doing so! Otherwise, this *lock-grip* (possible only via Power Bite) automatically shakes lose at the end of the melee round. **Note:** In the alternative, the Gunwolf can simply hold on to its prey inflicting only 1D4 M.D. by maintaining its grip, or fry it with its flamethrower in the back of the mouth.

b) Heavy Flamethrower: Same as the one deployed by the Beachmaster, except it is fired from the Gunwolf's mouth. Though it can be used to flush out bunkers and enemy positions, it is intended for use against creatures vulnerable to fire. Comes with valves that automatically seal it off underwater,

deactivating it and preventing water from contaminating the napalm reserve.

Primary Purpose: Anti-Structure.

Secondary Purpose: Anti-Personnel.

Range: 400 feet (122 m).

Mega-Damage: 1D4x10 M.D. to the target and anyone within 10 feet (3 m).

Rate of Fire: Each burst counts as one melee action/attack.

Payload: 48 bursts. The flamethrower can be refueled with military-grade napalm or use normal diesel or gasoline (reduced damage to 5D6 M.D.). 80 gallon (302 liters) fuel reserve.

c) Eye Lasers (2): Nestled within each eye socket is a short-ranged laser for extra combat capabilities and for use against creatures vulnerable to light energy.

Primary Purpose: Anti-Armor.

Secondary Purpose: Assault.

Mega-Damage: 2D6 M.D. per single blast or 4D6 M.D. per linked blast at the same target.

Range: 1,200 feet (366 m).

Rate of Fire: Each single or dual linked blast counts as one melee attack.

Payload: Effectively unlimited. 50 blasts per charge each for the electric battery model.

6. Hand to Hand Combat: The Gunwolf is uniquely designed for hand to hand combat with giant animals, monsters and armored foes; detailed below. See *Heavy Ground Robot Training* on page 352 of **Rifts® Ultimate Edition** for the number of attacks and bonuses.

Restrained Punch – 1D4 M.D.

Normal Punch – 2D6 M.D.

Normal Head Butt – 2D4 M.D.

Claw Strike/Raking with Claws – 3D6+4 M.D.

Power Claw Strike – 6D6+8 M.D., but counts as two melee attacks.

Power Claw Rip Strike – 1D6x10 M.D., but counts at three melee attacks and requires a simultaneous attack with both hands in which the Gunwolf strikes, tearing into its prey and then ripping up and away with both sets of clawed hands; rips with all its might. **Note:** The Gunwolf cannot parry the next attack after using this strike.

Kick Attack – 3D6 M.D.

Stomp – 1D6 M.D.

Running Ramming Attack – 3D6 M.D. and there is a 70% likelihood of knockdown against opponents of the same size, smaller and up to 20% larger. 45% chance against larger opponents up to twice the Gunwolf's size. Victims of knockdown lose initiative and two melee attacks. **Note:** This ram attack counts as two attacks.

7. Handheld Weapons: The robot's claws make it impossible to use giant-sized gun. Giant-sized melee weapons, clubs, etc. can be gripped and used, but at a penalty of -1 to strike, parry and disarm.

8. Wolf's Howl Anti-Monster System (1): The art of piloting Gunwolves is the ability to close the distance upon your adversary(s) and shred them apart. To assist in closing ranks and getting the jump on the enemy, be they monsters or robots, the Gunwolf is equipped with an experimental NG-RS-X Scrambler, dubbed the "Wolf's Howl" or just "Howler." Via the spinal fin emitters located on the back of Gunwolf, the Howler emits a variety of disruptive pulse waves at various

subsonic and ultrasonic frequencies simultaneously. *Monsters and animals with acute or enhanced hearing* (including Xiticix, Dog Boys, other mutant animals, some D-Bees, and vampires!), are sensitive to the ear-splitting noise, causing the creature's ears to hurt and head to throb. Moreover, it is disorienting and painful to the point that the creatures suffer the following penalties: Reduce Spd by 10%, -1 attack per melee, -3 on Perception Rolls, -2 on initiative, -1 to parry and dodge, -2 to pull punch, and -15% on the performance of all skills. **Note:** The Wolf's Howl also has a short-range scrambling effect on electronic communications and sensor systems, creating static, whistling and crackling on earphones and speakers and interfering with sonar, radar, and radio transmissions (may require repeating the message). All of this makes tracking and targeting difficult with a -15% penalty to Sensory Equipment and all Radio communications skill rolls. This gives the Gunwolf an advantage to locking onto confused or disoriented targets.

9. Sensor System Note: The Gunwolf has all the standard robot features plus the following.

A. Thermal-Imager: A special optical heat sensor that allows the infrared radiation of warm objects to be converted into a visible image. Enables the pilot to see in the dark, in shadows, and through smoke. **Range:** 2,000 feet (610 m).

B. Infrared and Ultraviolet Optics: This optical system projects a beam of infrared light that is invisible to the normal eye. The infrared beam enables the pilot to see in the dark and to see other infrared beams. The ultraviolet system enables the pilot to see into the ultraviolet spectrum of light and is mostly used to detect the light beams of ultraviolet detection systems. **Note:** The infrared light beam can be seen by anybody who also has infrared optics, and the beam can be traced back to its source. Smoke impairs the infrared beam, making it impossible to see.

C. Infrared Searchlights: The appendage behind the left shoulder can extend another six feet (1.8 m) and rotate up and down 360 degrees to light up an area. There are two lights on the top (one small, one long) and a large light on the underside. All are infrared lights used to scan an area at night using the invisible light to avoid detection. Only somebody who can also see infrared light will see the beam. **Range:** 500 feet (152 m).

D. Multi-Camera System: The Gunwolf has two cameras in each of its eye sockets, one on each forearm, two in the chest sensor cluster, one in each of the chest missile launchers, and two in the back. Each has a 4,000 foot (1,219 m) range with telescopic lenses as well as macro-lenses for seeing up-close. Includes image and video transmission capabilities.

NG-V67 Grizzly

The Northern Gun 'Grizzly' is aptly named. It is big, bad and capable of tearing its enemies to shreds in a matter of minutes. The design team of **Frederick Seibel the Fifth, Ammon Redman, Ramzie Othman** and **Jonathon E. Conroy** wanted to create a combat robot that was able to fill the role of armored troop support in the field, as well as a mobile bunker able to park itself and hold a strategic position, defend a town and tear apart swarms of Xiticix, monsters or gangs of demons, dimensional raiders and armored assailants. This makes the Grizzly, like the Gunwolf, suitable as a monster-slayer as well as a tank-killer.

Since its release six months ago, demand has been so great that NG has been unable to keep the Grizzly in stock, creating ever increasing demand and higher prices (50% to 200%) on the secondary market. (The Gunwolf and Gunbot have similar high demand and availability issues.) The Grizzly is one of the most heavily armored robot weapon platforms ever placed on the open market by NG. In fact, there was considerable debate about doing so. Many Northern Gun executives feared making such a powerhouse war machine available to independent kingdoms and mercenaries who might oppose the Coalition States could provoke a backlash from NG's Coalition ally. To the company's surprise, the CS has been silent on the matter. Many speculate it is because the Grizzly, though powerful, is slow and has limited combat applications, and because the CS recognizes the growing threat of the Xiticix and demonic enemies.

At a maximum speed of 35 mph (56 km), a height of 32.8 feet (10 m) and massive girth, the Grizzly is not ideal for wilderness travel or exploration. The tank-like track system built into the feet provides improved grip and traction for climbing and negotiating uneven terrain, but it is not enough to enable the Grizzly to trek through dense forest, deep mud or mountains; steep inclines of more than 40 degrees are unmanageable by the robot. However, the Grizzly does well in desert and prairie environments, city streets and debris-strewn battlefields. Likewise, it can wade through rivers and streams without fear of being swept away by the strongest of currents, and can walk along the floor of deep lakes and coastal waters. In fact, field tests by NG have shown that deploying the Grizzly in operations with the **Beachmaster** is a devastating combination in amphibious operations and beach assaults. However, so far, most purchasers have deployed the giant robot as an anti-monster defense, robot-killer and walking bunker to hold strategic positions and to defend outposts and towns.

For prosperous merc companies, towns and city-states, the Grizzly is ideal as a mobile artillery unit, walking guard tower and border defender. Its heavy construction, extra armor for the shoulders, arms, legs, knees, and main body, and its array of heavy weapons make it difficult for enemies to dispatch quickly. And when this beast of a robot engages in combat, it has a barrage of weapons with ranges of 4,000 feet (1,219 m) and greater. The Grizzly can turn 180 degrees at the waist enabling it to sweep across the field of battle with its full load out of weapon systems. In addition, the top, dual weapon turret can rotate 360 degrees, and the big laser cannon on the left shoulder can rotate to fire forward, upward and backward while other weapons are unleashed upon enemies at other positions in front of it. Both of these weap-

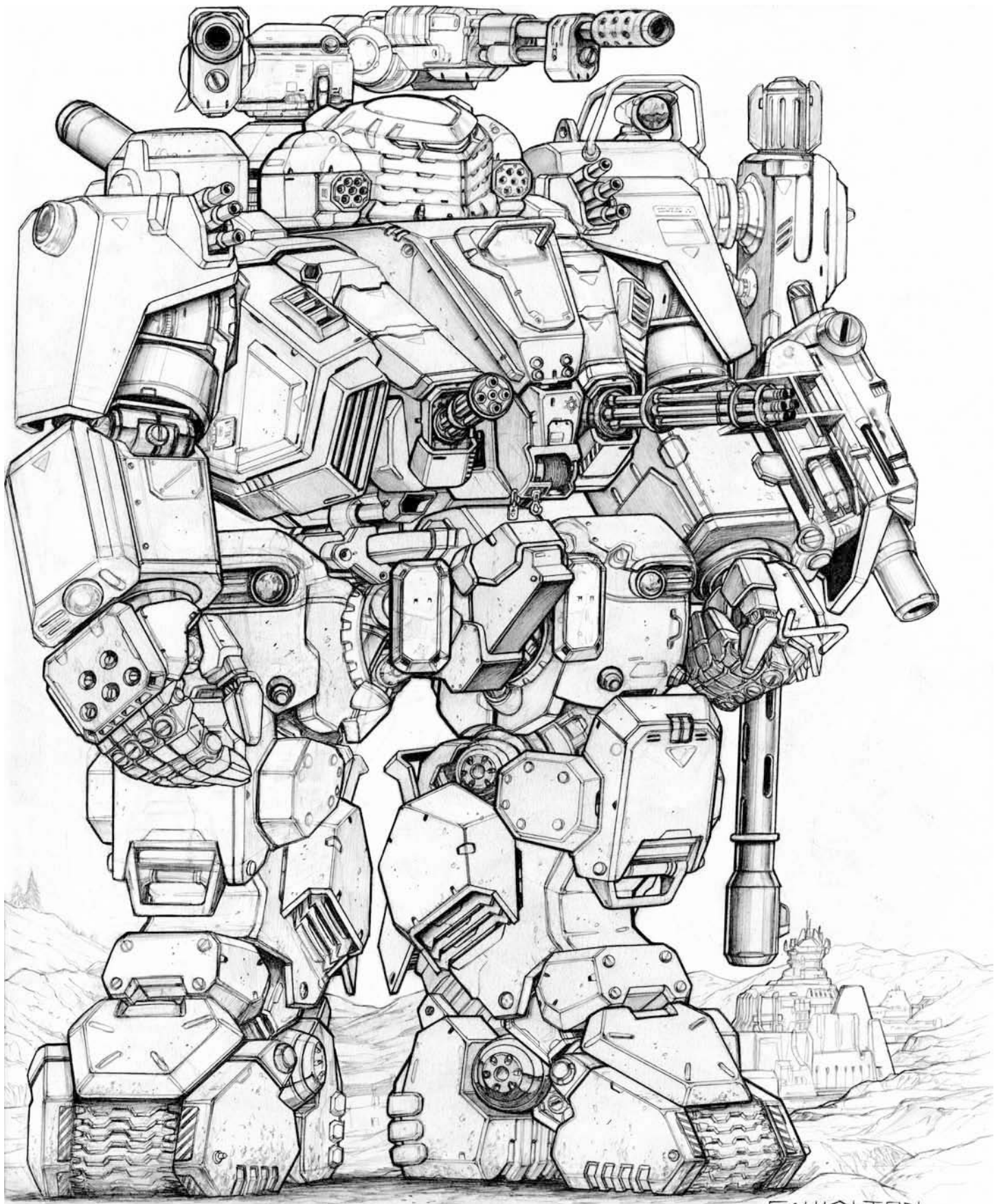

ons are so deadly, it is difficult to point to which qualifies as the Grizzly's 'main gun.'

Rail guns and other projectile weapons can be loaded with conventional ammunition or monster-slaying rounds to engage the supernatural and creatures of magic. Likewise, its modular forearm mounts enable energy weapons or grenade launchers to be swapped out with *monster-slaying weapons* such as wooden stake throwers, silver ammunition and water blasters. Regardless of type, all of the Grizzly's weapon systems inflict heavy damage to take down enemies fast. As a result, the robot's operators often fight to quickly damage and cripple enemy armor and monsters, slowing them down and making them 'more manageable' for the infantry troops (foot soldiers and power armor) to finish off. That said, the robot is capable of mowing down enemy infantry and destroying armored opponents on its own. It's just that the Grizzly offers the greatest strategic value in using its array of weapons to 'soften up' attackers and target and eliminate the enemy's armored units and heaviest hitters. That's part of its infantry support function. The other is to stand strong to hold off advancing enemy forces and cover troop retreats, extractions and EVAC operations.

Of course, unless there is a way to extract the mighty Grizzly quickly, the robot is likely to be overrun by the enemy, destroyed and its crew captured or slain. For this reason, the pilot and copilot are encouraged to wear environmental body armor that can accommodate a jet pack, such as the *NG Explorer Armor* with the *Falcon 300 jet pack*, to make a strategic run for it. The light, *Triax Terrain Hopper* power armor, and similar compact, light power armor, is also suitable for this purpose. There are two compartments where such a jet pack can be stowed inside the robot. Regrettably, it is probably prudent to initiate the destruct mechanism to fry the Grizzly's internal workings to prevent it from being captured and used by the enemy. **Note:** Self-destruct may not be necessary when fighting Xiticix and other animalistic opponents or enemies unable to use advanced technology, as they are likely to leave the robot standing where it is. Under such circumstances, locking the robot up and sneaking back to recover it at a later time *may* be an option.

Model Type: NG-V67 Grizzly.

Class: Anti-Armor, Anti-Monster and Infantry Artillery Combat Robot.

Crew: Two; one pilot (chest) and one copilot/gunner (head).

M.D.C. by Location:

- Top Weapon Turret (itself; center) – 170
- Top Weapon Turret Guns (2) – 150 each
- * Head – 230
- Reinforced Gunner's Compartment (head) – 50
- * Head Mini-Missile Launchers (2, sides) – 70 each
- * Chaff Tube Launchers (3 per shoulder) – 25 each
- * Sensor & Communications Cluster (1, top right) – 75
- * Searchlight (1, top left shoulder) – 20
- * Headlights (8, thighs, forearms, elsewhere; small) – 5 each
- Upper Arm & Shoulder Extra Exterior Plating (2) – 175 each
- ** Robot Upper Arms (robotic; 2) – 150 each
- Lower Arm Extra Exterior Plating (2) – 100 each
- ** Lower Arms (robotic; 2) – 125 each
- * Forearm Weapons (2; one per arm) – 100 each
- Hands Extra Exterior Plating (2) – 70 each
- ** Hands (themselves; 2) – 75 each
- Armor Buster Cannon (1; left) – 200

Chest Guns (2) – 75 each

Leg Exterior Plating (2) – 300 each

** Legs (robotic; 2) – 250 each

* Feet (2) – 220 each

Reinforced Pilot Compartment (chest) – 100

*** Main Body/Upper Torso – 700

* A single asterisk indicates a small and difficult target to strike, requiring the attacker to make a "Called Shot," but even then the attacker is -4 to strike.

This includes the head and its missile launchers because they are low profile and protected and obscured by the shoulder plating, rear gun turret (the head cannot be hit from behind) and various other systems and protrusions. **Note:** Destroying the head knocks out the Top Weapon Turret, Head Mini-Missile launchers and the Armor Buster Cannon.

** Two asterisks indicates an armored target that is vulnerable only after exterior plating is destroyed. It cannot be damaged until the 'Extra' exterior armor is reduced to zero. This is a feature unique to the Grizzly.

*** Depleting the M.D.C. of the main body shuts the vehicle down completely, making it useless.

Speed:

Running: 35 mph (56 km), a decent speed for a robot so large and heavily armored.

Leaping: Not possible.

Water: The Grizzly cannot swim, but can walk along the lake bed at a maximum speed of 10 mph (16 km). Maximum depth 2,000 feet (610 m).

Flying: Not possible.

Statistical Data:

Height: 32.8 feet (10 m).

Width: 22.4 feet (6.8 m).

Length: 19.7 feet (6 m).

Weight: 43 tons, fully loaded.

Physical Strength: Equal to a Robotic P.S. 40.

Cargo: Each cockpit has enough space to stow a jet pack, backpack, rifle, a couple canteens, and a few other small articles that could fit in a small duffle bag.

Power System: Nuclear; average energy life is 20 years.

Cost: Nuclear: 48 million credits. Alternative power supplies cannot be used due to the heavy drain of the ion weapons.

Weapon Systems:

Modular Weapons Note: Many of the Grizzly's weapon systems are modular and can be *swapped out* with an alternate weapon system. The standard weapon system is described below, with the optional replacement listed under it. To change a weapon system requires an Operator or NG Certified Mechanic, and takes 20-40 minutes unless stated otherwise. Even the simple forearm weapons take 6-10 minutes to remove and replace when the Operator has proper gear, double the time without it.

1. Top Mounted Weapon Turret (1 turret, two guns): Mounted on the back, behind the head of the Grizzly, are a pair of massive guns built into a turret. These guns can be heavy ion cannons or rail guns, depending on the purchaser or the demands of the combat mission. The pair are mounted on a turret that can turn 360 degrees.

The guns have a 120 degree up and down arc of fire and can engage in *linked fire* at the same target or split their at-

tacks between two completely different targets. To better accommodate this, each gun can move side to side 45 degrees independent of each other. **Note:** This weapon turret, the head mounted mini-missile launchers (below it), and shoulder tube launchers are operated by the gunner who sits in the head of the Grizzly. The pilot sits in the chest and operates the big gun and all other weapon systems, as well as handles movement and close combat.

NG-I-367 Ion Cannons (2): A pair of high-powered ion cannons are attached to the weapon turret as the standard issue weapon system. The cannon is hardwired into the robot's nuclear power supply, providing an unlimited payload. These guns are ideal for delivering good damage to enemy troops, armored vehicles and monsters. **Note:** The Ion Cannons are shown in the illustration.

Primary Purpose: Anti-Armor and Assault.

Secondary Purpose: Anti-Monster and Anti-Personnel.

Range: 2,000 feet (610 m).

Mega-Damage: 5D6 M.D. per single blast or 1D6x10 M.D. for linked fire with both guns shooting simultaneously at the same target.

Rate of Fire: Each single or dual linked blast counts as one melee attack.

Payload: Effectively unlimited.

ALTERNATE Weapon System: Rail Guns (2): A pair of rail guns that can be loaded with conventional M.D. ammunition or 'monster slaying' rounds of silver or wood. Many so-called 'monsters' that are *mortal* Mega-Damage creatures, such as Fury Beetles and dinosaurs, are just as susceptible to blasts from the ion cannons as human troops and war machines. However, many supernatural beings and creatures of magic are resistant or impervious to such weapons, or heal from their damage in a matter of minutes. Yet, many are vulnerable to ordinary items like silver, wood, bone or stone. Rail guns and other projectile weapons can fire some or all of these special monster-slaying rounds. Purchasers who know they are going to be facing supernatural beings with such vulnerabilities may want to load-up on weapons that can fire rounds that hurt such nemeses. Of course, the trick is having a balance of weapon systems that can be used against monsters and conventional M.D.C. troops.

Primary Purpose: Assault & Anti-Personnel.

Secondary Purpose: Defense.

Range: Conventional rail gun rounds and silver-coated rounds: 4,000 feet (1,219 m). Special, weighted wood rounds with silver rings: 2,000 feet (610 m).

Mega-Damage: Varies. Standard & Silver Ammo: A standard M.D. burst is 60 rounds and inflicts 1D4x10 M.D.; one round does 1D4 M.D.; 2D4x10 M.D. for a dual burst in linked fire at the same target (counts as one melee attack).

Special Ammo Rounds: Silver, wood, etc., same as the Gunwolf (see page ***). These are S.D.C. rounds that do 1D4 S.D.C., 1D4x10 S.D.C. or 2D4x10 S.D.C. for a dual, simultaneous blast.

Rate of Fire: Each single shot or burst counts as one melee attack.

Payload: 18,000 rounds total. Four 2,250 round drums (9,000 total rounds), two for each rail gun, with enough ammo for 150 bursts for each gun (300 bursts total). **Note:** Reloading a Grizzly's rail gun requires loaded ammo drums being available and special equipment or another giant-sized robot and a readily available ammo drum. It takes about 15 minutes for those not

trained, but a mere five minutes by somebody trained in Robot Mechanics or who is an Operator.

2. Armor Buster, Long-Range Laser Cannon (1, left shoulder): The Armor Buster cannon is also known as the *Big Gun*.

It is one of the few weapon systems that cannot be swapped out for an alternate weapon system. The cannon can rotate 360 degrees up and down, and spin to fire backward, but the entire upper torso must move to fire upon a designated target. The Big Gun is fired by the pilot.

Primary Purpose: Anti-Armor and Assault.

Secondary Purpose: Anti-Monster and Anti-Personnel.

Range: 4,000 feet (1,219 m).

Mega-Damage: 6D6+4 M.D. per single blast.

Rate of Fire: Each single only.

Payload: Effectively unlimited.

3. Mini-Missile Box Launchers (2, top): On each side of the head is a pepper box-style mini-missile launch system. To aim at a specific target, the head must turn to face it. The head and its launchers can turn left and right 120 degrees and have a 45 degree up and down arc of fire. They are controlled by the copilot/gunner seated inside the head. There is no alternate weapon system for this item, though *smoke* and *Hex mini-missiles*, both known to have an impact on supernatural monsters and creatures of magic, may be part of the payload or replace it. (See #4 Flare Chaff Launcher Alternate Payloads for details on the Hex loadout.)

Primary Purpose: Anti-Aircraft, Anti-Missile and Anti-Flyers.

Secondary Purpose: Anti-Personnel/Monsters and Anti-Armor.

Range: One mile (1.6 km).

Mega-Damage: Varies by missile type, but *high explosive* (1D4x10 M.D.) And *plasma* (1D6x10 M.D.), for use against creatures vulnerable to fire, is standard.

Rate of Fire: One at a time or in volleys of 2, 3, 4, 5, 6 or 7.

Payload: 70 total, 35 per launcher; automatic reload.

4. Shoulder Flare Chaff Launchers (3 per shoulder; 6 total):

Housed in the upper shoulders are six tube launchers equipped with flare chaff rockets. The chaff rockets explode at a preset altitude or location indicated by the pilot, creating a cloud of sparkling light, bright flashes, chaff, foil and particles, designed to foil incoming missiles and airborne flyers, including Gargoyles, dragons, other flying monsters, rocket bikes, jet pack troops, power armor and aircraft. Each tube fires one missile, but several tubes can be fired in unison to create a larger and denser chaff cloud.

Primary Purpose: Anti-Missile.

Secondary Purpose: Anti-Flyers.

Range: 6,000 feet (1,829 m).

Chaff vs Missiles: The chaff cloud has a chance of causing them to explode before striking the Grizzly or other nearby target. A single chaff cloud has a 10% chance of exploding any volley of missiles that enters the cloud. Increase the chance of success by 10% for each additional chaff rocket fired. Thus, a volley of two chaff rockets has a success rate of 20%, three rockets: 30%, four rockets: 40%, five: 50% and six (a maximum volley), 60%. Upon detonation of a missile or missile volley the chaff cloud is destroyed and dispersed, but the incoming missiles are destroyed.

Chaff vs Aircraft and Flyers: Flying aircraft, power armor and beings caught in a chaff cloud momentarily have their vision impaired, sensors fouled and suffer the following penalties: -6 on Perception Rolls, -3 on initiative, -5 to strike, -2 to parry and

dodge, and lose one melee attack for the rest of that round (or the next melee round if they enter or are caught inside a chaff cloud at the end of a melee). Moreover, the chaff cloud temporarily negates any laser or optics based targeting bonus and inflicts a -20% skill penalty to Sensory Equipment and Piloting for that melee round. Such penalties last for as long as the character is in the chaff cloud (typically only a second or two) and for the rest of that melee round for vision and sensor systems to recover (the next melee/15 seconds, if the character enters the cloud at the end of melee round). It has a similar effect as a Flash grenade.

Chaff Cloud Size: 30 foot (9.1 m) diameter cloud, increase an additional 10 feet (3 m) per each chaff rocket fired in the same volley. Only rockets fired in that volley count toward the detonation of incoming missiles (60% maximum).

Duration: The chaff cloud lasts two melee rounds or until destroyed.

Rate of Fire: One at a time or in volleys of 2, 3, 4, 5 or 6.

Payload: 30 total, five per launcher.

ALTERNATE Grenade or Flare Payloads: Rather than fire chaff rockets, the tubes can unleash grenades or flares that have proven to have a negative impact on the supernatural and creatures of magic with a superior sense of smell.

Primary Purpose: Anti-Monster.

Secondary Purpose: Anti-Personnel.

Range: 2,000 feet (610 m) when fired by the Chaff Launcher.

Anti-Monster Grenade Damage/Effects: A typical payload is 10 smoke and 20 Hex grenades, or an entire payload of one or the other.

a) Conventional Smoke Grenades: Smoke is effective in obscuring the vision of most monsters and supernatural beings. Those caught inside a smoke cloud are blind, unable to see beyond their noses or what else is inside the cloud. Those standing outside a smoke cloud cannot see through the cloud and will not know what is happening on the other side of it unless they go through it, around it or over it (they cannot see what is in the cloud or on the other side). Smoke is excellent for concealing an escape or obscuring an impending attack. The same is true of fog. Duration: 1D4+4 minutes; half in strong wind (25 mph/40 km or greater).

b) Hex Grenades: The so-called 'Hex' grenade is a pre-Rifts chemical weapon rediscovered by the Coalition States and whose secrets have been recently shared with Northern Gun. It unleashes a smoke cloud that consists of hexachloroethane, grained aluminum and zinc oxides, producing a zinc chloride-oxychloride and hydrochloric acid emission that absorbs the moisture in the air in a 20 foot (6.1 m) radius. The chemical toxicity is created by the strong hydrochloric acid and thermal effect reacting from the zinc chloride and water.

Duration of Hex Grenade Effects: The cloud lasts for 1D4+3 melee rounds (half that in a strong wind), but the full penalties for the initial effects last for 1D6+2 minutes after exposure to the toxic cloud. After that initial period, reduce the penalties by half for an additional 2D4x10 minutes of mortal beings. The latter is not applicable to supernatural beings and creatures of magic; see below. (**Note:** In the real world, victims suffer from symptoms for 12-48 hours, can develop lasting respiratory problems, delayed pulmonary edema and cyanosis, and in some cases, death. Most people require several hours to a few days to recover. Respirators are required as proper treatment for people coming into contact with hydrochloric acid smoke.)

Damage from Hex Grenades: When inhaled by *humans, D-Bees and animals* (including monstrous ones), the chemical cloud affects breathing and respiration, and can cause lesions in the upper passageways and lower airways to cause dyspnea and retrosternal pain (labored breathing and pain behind the breast bone associated with heart and lung disease). Victims cannot catch their breath, breathing is labored, they are struck with bouts of severe coughing, and the throat is so immediately and severely irritated that the voice becomes hoarse and raspy, making it difficult to talk. Hex Effects as Penalties: -2 melee attacks, -6 on Perception rolls, -4 on initiative, -2 to strike, parry, dodge, and disarm, reduce Spd by half, and -20% on skill performance.

Against mortal 'Mega-Damage' creatures, including Xiticix, dinosaurs, and most animals and mortal monsters, the toxic cloud has the same effect as above, except all of the initial penalties are *half*. Duration of the initial effect is the same, but the lingering penalties are reduced by half, again, and last only 3D6 minutes.

Against dragons, creatures of magic, some demons and many supernatural beings (including demigods, godlings and Daemonix), the toxic cloud has the same effect, except reduce all of the initial penalties and duration by *half*. After the initial penalties end, there are no lingering effects. The monster is back up to full speed and ability unless exposed to the acidic smoke again. **A note on supernatural beings and creatures of magic who suffer full penalties:** Those beings with *keen olfactory senses*, including *Loup Garou, Wendigo, Werebeasts* and others, suffer the full penalties for the full duration of the initial effects. The lingering effects see penalties reduced by half and last only 1D6 minutes. **A note on beings completely immune to the effects:** The toxin has no effect on animated dead, the undead, Elementals, and beings resistant or impervious to sulfur and other toxic gases, nor those beings who can breathe fire. Of course, the toxic smoke has no effect on people inside environmental armor or inside a sealed, environmental system/vehicle/robot or power armor.

Saving Throw: 16 or higher vs non-lethal toxin.

Area of Effect: 20 foot (6.1 m) radius for the Hex smoke cloud. EVERYONE caught inside the cloud must roll to save. A successful save means half the penalties for 1D4 melee rounds with no lingering effects.

Rate of Fire: Same as chaff, one at a time or in volleys of 2, 3, 4, 5 or 6.

Payload: Same as chaff, 30 total. Five per launcher.

Note: Also available as a mini-missile with a range of 3,000 feet (914 m).

Cost: 2,500 credits per grenade and 7,500 credits per mini-missile. Poor availability.

c) TW Flares! In the alternative, though it is not 'official' and such items are not sold by NG, the tube launchers can fire Techno-Wizard Flares such as *Globe of Daylight Flares* and *TW Storm Flares* to ward off and damage supernatural beings vulnerable to such things. Duration, area of effect and damage as per TW item.

5. Belly Gun Type One: Heavy, Long-Range Rail Gun (1):

A pair of rail guns are a standard issue weapon system; one long-range and one medium-range. Both can be loaded with conventional M.D. ammunition or 'monster slaying' rounds. Both can retract inside the robot to protect the weapon when engaged in hand to hand combat. They cannot fire when retracted and concealed.

Primary Purpose: Assault & Anti-Personnel.

Secondary Purpose: Defense.

Range: Conventional rail gun rounds and silver coated rounds: 4,000 feet (1,219 m). Special, weighted wood rounds with silver rings: 2,000 feet (610 m).

Mega-Damage: Varies. Standard & Silver Ammo: A standard M.D. burst is 60 rounds and inflicts 1D4x10 M.D.; one round does 1D4 M.D.; 1D6x10 M.D. at the same target (counts as one melee attack) when linked-fired with the medium belly rail gun.

Special Ammo Rounds: Silver, wood, etc., same as the Gunwolf (see page 132) These are S.D.C. rounds that do 1D4 S.D.C., 1D4x10 S.D.C. or 2D4x10 S.D.C. for a dual, simultaneous blast.

Rate of Fire: Each single shot or burst counts as one melee attack.

Payload: 9,000 rounds total with enough ammo for 150 bursts.

Note: Reloading, same as the previous rail gun.

6. Belly Gun Type Two: Medium NG-223 Rail Gun (1): A medium rail gun is built into the belly and used against close targets and on opponents while grappling or locked in hand to hand combat. Like the other rail guns, it can fire conventional rail gun rounds, conventional silver-coated rounds or special wood and silver rounds.

Primary Purpose: Assault & Anti-Personnel.

Secondary Purpose: Defense.

Range: Conventional rail gun rounds and silver-coated rounds: 2,000 feet (610 m). Special, weighted wood rounds with silver rings: 1,000 feet (305 m).

Mega-Damage: Varies. Standard & Silver Ammo: A standard M.D. burst is 60 rounds and inflicts 5D6 M.D. (+4 M.D. to opponents at point-blank range; within 10 feet/3 m) for a burst. One round does 1-2 M.D.

Special Ammo Rounds: Same. These are S.D.C. rounds that do two S.D.C. per round and 5D6 S.D.C. per burst.

Rate of Fire: Each single shot or burst counts as one melee attack.

Payload: 12,000 rounds total with enough ammo for 200 bursts.

Note: Reloading, same as the previous rail guns.

a) ALTERNATE Weapon System for Belly Guns: Dual Ion Guns:

Primary Purpose: Anti-Personnel and Assault.

Secondary Purpose: Anti-Monster and Defense.

Range: 1,600 feet (488 m).

Mega-Damage: 4D6+4 M.D. per single blast or 1D4x10+2 M.D. for linked fire of both laser guns firing simultaneously at the same target.

Rate of Fire: Each single or dual linked blast counts as one melee attack.

Payload: Effectively unlimited.

Cost: 178,000 credits for the pair.

b) ALTERNATE Weapon System for Belly Guns: Dual Laser Guns:

Primary Purpose: Anti-Personnel and Assault.

Secondary Purpose: Anti-Monster and Defense.

Range: 2,000 feet (610 m).

Mega-Damage: 4D6 M.D. per single blast or 1D4x10 M.D. for linked fire of both ion guns firing simultaneously at the same target.

Rate of Fire: Each single or dual linked-blast counts as one melee attack.

Payload: Effectively unlimited.

Cost: 155,000 credits for the pair.

c) ALTERNATE Weapon System for Belly Guns: Dual Flamethrowers: Same as the Gunwolf or Beachmaster, including 80 gallon (302 liter) payload. Cost: 140,000 credits.

Note: All of the alternate weapon systems above can be used to replace either one or both of the belly guns.

7. Standard Right Forearm Weapon: Flamethrower (1): A flamethrower attachment is the standard weapon system. It is used to flush out bunkers and enemy positions, against foot soldiers and also very effective against monsters and supernatural beings vulnerable to flame. Of course, most animals are afraid of fire too. The flamethrower is designed to be waterproof and comes with valves that automatically seal it off underwater, deactivating it and preventing water from contaminating the napalm reserve.

Primary Purpose: Anti-Structure and Anti-Personnel.

Secondary Purpose: Anti-Monster.

Range: 200 feet (61 m).

Mega-Damage: 1D4x10 M.D. to the target and anyone within 10 feet (3 m). Those caught within reach of the flamethrower's attack inside small, enclosed areas like bunkers, caves or non-sealed vehicles and without environmental gear or oxygen, must roll to save vs poison (smoke inhalation and lack of air) or be rendered unconscious for 1D4 melee rounds.

Rate of Fire: Each burst counts as one melee action/attack.

Payload: 10 bursts. The flamethrower can be refueled with military-grade napalm or use normal diesel/gasoline (reduces damage to 3D6 M.D.). 20 gallon (76 liters) fuel reserve.

Cost: 50,000 credits as an alternative modular attachment.

a) ALTERNATE Weapon System for Right Forearm:

L-555 Multiple-Target Laser: This new design looks just like the Searchlight and Holographic Projector with a few subtle differences (and is depicted in the illustration). The L-Five-Fifty-Five is a new, experimental weapon system currently only available to the Grizzly, though as a modular component, could easily be adapted to other large robots.

The NG-L-555 has a special targeting system that identifies and paints up to five different targets within its limited range. The wide spread can be as much as a 45 degree arc of fire in width and up and down. The weapon then fires a simultaneous, laser blast at *each* target. Damage is light, but hits several targets in a single laser volley. Note: The L-555 is based on weapon plans stolen by NG from Wilk's Research and Development during one of several acts of industrial espionage.

Primary Purpose: Anti-Personnel and Assault.

Secondary Purpose: Anti-Missile and Defense.

Range: 1,000 feet (61 m).

Mega-Damage: 1D6 M.D. to each target. Can NOT concentrate fire on any one target unless it is 20-40 feet (6.1 to 12.2 m) wide, like a wall or the side of a large vehicle, and even then the beams hit in a wide, scatter pattern, not clustered on one narrow target or area like the tires or a sensor array.

Rate of Fire: Each blast of up to five simultaneous shots at five different targets counts as one melee action/attack.

Payload: Effectively unlimited; tied to the Grizzly's power supply.

Cost: 115,000 credits.

Note: NG is trying to build a rifle based on the same principle, but has had no luck so far. Wilk's is almost certain to beat them to the punch with such a weapon.

b) ALTERNATE System for Right Forearm: NG-SH-7

Searchlight: Rather than a weapon, the arm is equipped with a pair of long-range searchlights, one infrared and one in visible light. Can also be used as a lantern to illuminate a 30 foot (9.1 m) radius.

Primary Purpose: Illumination of Target.

Secondary Purpose: Search and Rescue.

Range: 1,500 feet (457 m).

Mega-Damage: None.

Rate of Fire: Each repositioning of the light in an attempt to locate a specific target/subject counts as one melee action/attack. Keeping the light trained on the subject/location counts as one melee attack/action.

Payload: Effectively unlimited; tied to the robot's power supply.

Cost: 25,000 credits.

c) ALTERNATE System for Right Forearm: 3D Camera & Holographic Projector:

Instead of a gun, a trio of digital cameras, recording and holographic systems are built into the modular attachment; point and film. This can be used to record enemy troop movement, defenses and attacks, as well as to film and transmit data of all kinds, including possible traps, ambush positions, breaches and damage to fortifications, recording the faces of all who come to a specific checkpoint or guard station, etc.; includes facial recognition software to identify known fugitives and known enemy combatants (provided there are photographic records of their appearance).

Two of the cameras have a 4,000 foot (1,219 m) range with telescopic lenses. The third is a dedicated macro-lens for filming details up-close. Includes image and video transmission capabilities.

The cameras can record and store up to 6,000 hours of footage into memory. Video footage can also be transmitted live to a HUD and/or video screen of the pilot and gunner, or stored for later review. Footage can also be sent out as video transmissions and images by linking to a proper communications relay system of another robot, vehicle or portable system, or shared and downloaded via headjacks, fingerjacks and so on, into cyborgs to watch footage or onto computer disks and data file holders. Such footage is usually used for combat analysis, field studies, combat training, mission briefings and intelligence.

The facial recognition system is used to confirm the identify of officers and key personnel (heck, all personnel) assigned to a particular unit, as well as visiting dignitaries and known enemies, at checkpoints and during combat operations. Up to 10,000 faces can be stored. Takes 1D4 minutes to sort through the data files and requires a minimum of six different points of reference to 'greenlight' an I.D.

The holographic projector can be used to project recordings onto flat, light surfaces like a traditional video or as 3D images. Ideal for reviewing recorded data, investigations, and mission briefings. **Note:** Cannot film and project at the same time; one or the other.

Primary Purpose: Intelligence and Tactical Visual Recordation.

Secondary Purpose: Security and Identification.

Range: 4,000 feet (1,219 m) for long-range cameras. 500 feet (152 m) for holographic projections.

Mega-Damage: None.

Rate of Fire: Each deliberate snapshot or five seconds of video recording counts as one melee attack/action (point, aim and shoot).

Payload: 6,000 hours of continuous footage.

Cost: 120,000 credits.

Note: This is another system pirated from Wilk's via industrial espionage.

d) ALTERNATE System for Right Forearm: Long-Range Communications and Data Relay Capabilities:

Wide-band and directional radio communications system with built-in scrambler that transmits both audio and video from the cockpit, communications suite and battlefield video. Effective range of 500 miles (800 km); one third that range in the mountains, underground, and during storms. Includes the capability of sending and receiving scrambled/coded audio and video transmissions.

Audio pick-up and filtration system works both multi-directionally and as a shotgun mic. It can pick up sound as quiet as a whisper up to 400 feet away (122 m) and can sift through ambient sound for specific noises. Up to 100 hours of audio can be recorded and kept on file.

Primary Purpose: Long-Range Communications.

Cost: 75,000 credits.

8. Standard Left Forearm Weapon: Wooden Spike Thrower

(1): This is a monster-fighting weapon that fires thick, two foot (0.6 m) long wooden stakes; also effective against S.D.C. opponents.

Primary Purpose: Anti-Monster and Assault.

Secondary Purpose: Anti-Personnel.

Range: 1,200 feet (366 m).

Damage: 2D6 Hit Points/S.D.C. damage per single stake to ordinary mortals and S.D.C. beings, typically double damage direct to Hit Points to vampires and other beings vulnerable to wood. Can also shoot a rapid-fire burst of three stakes doing 4D6 S.D.C. or six stakes doing 1D6x10 S.D.C. per burst, but only one stake can be fired to make a carefully aimed shot. **Ammo Note:** The Spike Thrower is designed in such a way that it can accommodate similar sized and shaped stakes made of bone, stone, iron or silver (or silver-coated stakes of wood) to battle creatures vulnerable to these other materials. While Northern Gun does make a limited selection of such specialized ammo for the retail market, they are not commonly available. Silver-coated bullets and other types of anti-monster ammunition and vampire fighting gear are often shipped out and sold only in regions where there is a large demand for such goods. Of course, mercenary companies and long-standing clients can place special orders for anything NG makes, though manufacture and delivery may take a month or longer (1D4+3 weeks). Furthermore, there may be a minimum quantity required, especially for ammunition.

Rate of Fire: A single wooden stake or burst of 3-6 counts as one melee attack/action.

Payload: 36 stakes. Additional stakes can be loaded by hand (takes one melee round to load four stakes), and there is a storage locker in the pilot compartment that can stow a dozen stakes (or four mini-missiles) in addition to the usual storage space.

a) ALTERNATE Weapon System for Left Forearm:

Grenade Launcher (1): A grenade launcher is mounted on the left arm.

Primary Purpose: Anti-Armor and Anti-Fortifications.

Secondary Purpose: Anti-Personnel and Anti-Monster.

Range: 1,200 feet (366 m).

Mega-Damage: Varies with the type of grenade.

Rate of Fire: One at a time or in volleys of 2.

Payload: 42 total. Must retract to reload after its payload of 7 has been fired. It takes one melee round (15 seconds) for the automatic reload.

Cost: 75,000 credits for the launcher, plus the cost of each grenade.

b) ALTERNATE Weapon System for Left Forearm:

Mini-Missile Box Launcher (1): A box-style mini-missile launcher is mounted on the forearm.

Primary Purpose: Anti-Aircraft, Anti-Missile and Anti-Flyers.

Secondary Purpose: Anti-Personnel/Monsters and Anti-Armor.

Range: One mile (1.6 km).

Mega-Damage: Varies by missile type, but *plasma* (1D6x10 M.D.), for use against creatures vulnerable to fire is standard.

Rate of Fire: One at a time or in volleys of 2, 3 or 4.

Payload: 12 total.

Cost: 85,000 credits for the launcher, plus cost of each mini-missile.

9. Hand to Hand Combat: The Grizzly is not intended for close combat, but can handle itself well when it must, delivering heavy punches. See *Heavy Ground Robot Training* on page 352 of **Rifts® Ultimate Edition** for the number of attacks and bonuses, modified as indicated below.

Restrained Punch – 1D4+1 M.D.

Punch – 2D6+3 M.D.

Power Punch – 4D6+6 M.D. (+1D6 M.D. additional for the hand that has knuckle spikes; typically the left), but counts as two melee attacks.

Stomp – 2D4 M.D.

Head Butt – Not possible.

Kick Attack and Leap Kick – Not possible.

Running Ramming Attack – Standard.

Bonus Modification due to Size and Weight: The usual bonuses to parry and dodge are reduced; only +1 to parry and dodge.

10. Handheld Weapons: The robot's very large armored hands make it impossible to use most giant-sized guns. Giant-sized melee weapons, clubs, etc., can be gripped and used without penalty.

11. Sensors and Other Features of Note: The Grizzly has all the standard robot features plus the following.

A. Thermal-Imager: A special optical heat sensor that allows the infrared radiation of warm objects to be converted into a visible image. Enables the pilot to see in the dark, in shadows, and through smoke. **Range**: 2,000 feet (610 m).

B. Infrared and Ultraviolet Optics: This optical system projects a beam of infrared light that is invisible to the normal eye. The infrared beam enables the pilot to see in the dark and to see other infrared beams. The ultraviolet system enables the pilot to see into the ultraviolet spectrum of light and is mostly used to detect the light beams of ultraviolet detection systems.

Note: The infrared light beam can be seen by anybody who also has infrared optics, and the beam can be traced back to its source. Smoke impairs the infrared beam, making it impossible to see.

C. Infrared Searchlights: The appendage behind the left shoulder can extend another six feet (1.8 m) and rotate up and down 360 degrees to light up an area. There are two lights on the top (one small, one long) and a large light on the underside. All are infrared lights used to scan an area at night using the invisible light to avoid detection. Only somebody who can

also see infrared light will see the beams. **Range**: 500 feet (152 m).

D. Multi-Camera System: The Grizzly has four cameras in the chest, one in each weapon arm and two in the thigh just about the knee plate of the legs. Each has a 4,000 foot (1,219 m) range with telescopic lenses as well as macro-lenses for seeing up-close; x10 magnification. Includes image and video transmission capabilities (100 mile/160 km transmission range). Can store up to 10,000 hours of video footage before requiring transfer to some other medium. Includes image and video transmission capabilities.

E. Winch and Cable: Located in the belly area, between the two chest guns is a winch, hook and tow line for pulling cargo and assisting other robots and vehicles, as well as for climbing and securing the Grizzly itself.

NG-V7 Hunter Mobile Gun The 'Original' Model

The Hunter Mobile Gun is one of Northern Gun's most famous robots. It has served mankind for decades, a true NG original centered around the massive Howitzer rail gun whose plans were recovered near the end of the Two Hundred Years Dark Age. Northern Gun has been selling the venerable V7 Hunter for nearly thirty years now, offering a full-size, fully armed combat robot at a time when only the Coalition and a handful of nation-states boasted comparable war machines. A time when virtually no one else in North America had thirty foot (9.1 m) metal giants or self-propelled field guns, and certainly not both in the same package.

One of Northern Gun's most popular and iconic robots ever released, even today, after nearly 30 years on the market, the Hunter Mobile Gun remains in wide used by Robot Pilots, mercenaries, explorers, adventurers and high-tech bandits throughout North, Central and South America. It is known for being easy to pilot and a dependable workhorse in the field. Its Howitzer rail gun and mini-missiles make it one tough mother in a fight. Its humanoid shape is suitable for most terrains whether it is on the plains, in the forest or slogging through swamps. Humanoid arms and hands allow the robot to gather specimens during explorations, set up and carry equipment, work on other robots, and wrestle with dinosaurs and giants. The Hunter is capable of satisfying the role of border patrols, sentry duty, artillery positions, troop support, exploration and monster hunting.

Due to its popularity, NG has considered releasing various different versions of the Hunter Mobile Gun for years. However, market research has shown the familiar robot is what the customer wanted, so the Hunter has been sold as originally designed, with only modest upgrades to its armor, electronics and internal components for more than two generations. (See the **NG-V7 Block IV** for the first *new* Hunter ever released. Its description immediately follows this one.)

This has created a huge *secondary market* for 'previously owned' Hunter Mobile Guns. Ironically, this lower priced market for used and rebuilt Hunters has made the legendary robot all the more familiar and popular. Even robots that have been ancient

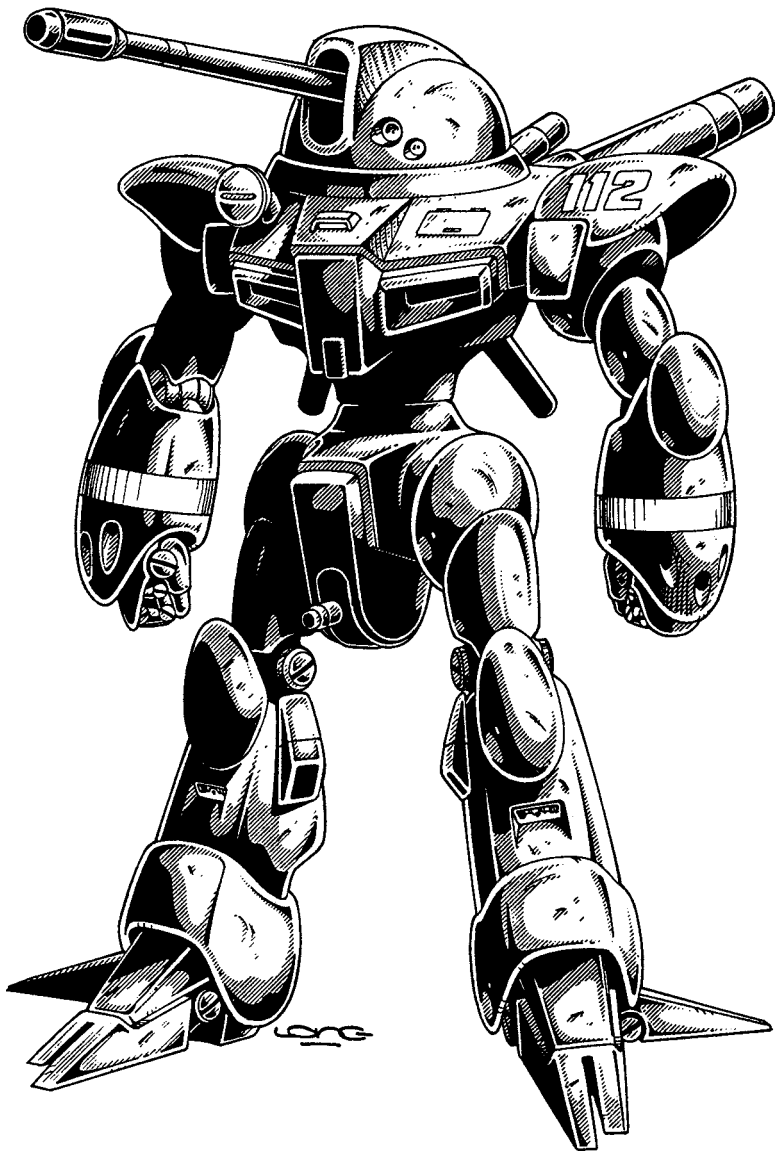

rebuilt and look like patchwork, mechanical Frankenstein monsters, command a decent price and perform nearly as well as new models right off the NG assembly line. This makes the NG-V7 Hunter as trusted and desired as ever. And affordable. Rebuilt models are among the most affordable 'big' robots around.

Note on Used NG-V7 Hunters: *Used and partially rebuilt NG-V7s* typically have 2D6% less M.D.C., but otherwise perform to all the standard specifications as a new unit. Price is typically 20-40% less than new.

Patchwork Hunter Mobile Guns have taken a beating and undergone comprehensive to near total reconstruction at least once, and very likely several times. Each M.D.C. location will have 1D4x10% less M.D.C., speed is reduced by 1D4x10%, 1D4 standard robot features are missing or inoperable, and one of the secondary weapons is likely to be missing or not working. Price is typically 40-60% less than a new one.

'Original' Hunter Mobile Gun Assault Robot

Model Type: NG-V7 Block I, II and III (the last had 10% more M.D.C. for all the robot's limbs, head/turret and main body).

Class: Infantry Assault Robot Vehicle.

Crew: Three: One pilot, one copilot and gunner, plus four passengers in cramped conditions. **Note:** The controls are designed

so that the pilot can handle all functions and weapons if necessary.

M.D.C. by Location:

Upper Arms (2) – 90 each

Forearms with Rocket Launchers (2) – 140 each

Hands (2) – 50 each

Legs (2) – 220 each

Feet (2) – 160 each

Head/Rail Gun Turret (1; top) – 160

* Crotch Blaster (1) – 20

* Chest Spotlight (1; near right shoulder) – 6

Leg Headlights (2; one in each lower leg) – 5 each

* Sensor Eyes (4; in turret) – 5 each

* Vent Tubes (4; back) – 30 each

** Main Access Hatch (1; chest) – 75

Emergency Hatch (1; top, rear) – 75

Reinforced Pilot Compartment – 120

*** Main Body – 490

* A single asterisk indicates a small and difficult target to strike, requiring the attacker to make a *Called Shot*, but even then the attacker is -4 to strike.

Destroying all four of the sensor eyes mounted in the gun turret destroys the main radar, targeting system and optics. This leaves the pilot to rely on his own human senses and eliminates any combat bonuses the sensors provided to strike, parry or dodge. **Note:** The sensor eyes are even smaller targets and require an attacker to make a *Called Shot* with a penalty of -5 to strike.

** Depleting the M.D.C. of the hatch makes the robot's inner pilot compartment vulnerable to entry by the enemy, provided the enemy can climb up or fly over the robot. The inner hatch has only 20 M.D.C.

*** Depleting the M.D.C. of the main body will effectively destroy the robot, shutting it down completely, rendering it useless.

Speed:

Running: 70 mph (112 km) maximum. Note that the act of running does NOT tire the pilot and speed can be maintained indefinitely.

Leaping: Not recommended because the disproportionately large head and top-heavy upper body are likely to cause the robot to veer off balance and fall, head first. A leap is possible only with a running start and limited to six feet (1.8 m) high and up to 20 feet (6.1 m) across. There is a 01-62% likelihood of falling over (a roll of 63% or higher means sticking a successful landing, but 62 or less means a fall, causing the Hunter to lose all its attacks for one melee round while the pilot struggles to stand the robot back up on its feet).

Water: Cannot swim, but can walk along the bottom of lakes and seas at about half its normal speed. Maximum depth tolerance is 2,500 feet (762 m).

Flying: Not possible.

Statistical Data:

Height: 32 feet (9.7 m).

Width: 19 feet (5.8 m).

Length: 14 feet (4.3 m).

Weight: 34 tons fully loaded.

Physical Strength: Equal to a Robotic P.S. 40

Cargo: Minimal storage space; about four feet (1.2 m).

Power System: Nuclear; average energy life is 20 years.

Cost: 40 million credits. Excellent availability in Michigan, Iron Heart, Free Quebec, the Midwest and most places in the Domain of Man. Fair availability of new NG-V7s most everywhere else within North America. Poor availability in South America and other markets outside the Americas. Fair to good availability of used, rebuilt and patchwork Hunters on the secondary market.

Weapon Systems:

1. NG-H155 Howitzer Rail Gun (1): The main weapon of the classic NG-V7 Hunter is its rapid-fire, automatic, self-loading, Howitzer rail gun. The big gun can be fired by any crew member, or the designated gunner. The Howitzer rail gun is housed in a protective turret that can rotate 360 degrees and has a gun arc of 90 degrees up and down. This gives the weapon good range and excellent angle of fire suitable against ground and air targets. However, it also means there is a 20 foot (6 m) blind spot at its feet and a 30 foot (9 m) blind spot directly above its head.

Primary Purpose: Anti-Armor and Assault.

Secondary Purpose: Anti-Aircraft and Anti-Missile.

Range: 6,000 feet (1,828 m).

Mega-Damage: 1D6x10 M.D. per single burst (40 rounds) or 2D6x10 M.D. per double blast (rapid-firing of two full bursts at the same target).

Rate of Fire: Each single shot or burst counts as a single melee action/attack.

Payload: Two 80,000 round drums; that's 2,000 single bursts per drum or 1,000 double bursts. The second drum feeds immediately after the first drum is exhausted. Reloading a drum takes about two minutes with the proper equipment and training, but 1D6x10 minutes for anyone who is not a robot or weapon system specialist.

2. Forearm Rocket Launchers (6 total; 3 per arm): Low profile, recessed mini-missile launch tubes are built into each forearm. Point and shoot.

Primary Purpose: Anti-Armor and Anti-Aircraft.

Secondary Purpose: Anti-Personnel and Defense.

Range: One mile (1.6 km).

Mega-Damage: Varies with missile type. Usually fragmentation (5D6 M.D.) or plasma (1D6x10 M.D.).

Rate of fire: One at a time or in volleys of 2, 3, 4 or 6.

Payload: 18 total; nine per arm.

3. NG-330 Heavy Laser (1, Crotch Gun): A single-barreled laser is located on the lower abdomen area of the Hunter. Its primary purpose is to disperse enemy ground troops around its feet and in the blind spot of the main gun. The turret can rotate 180 degrees downward, forward and backwards.

Primary Purpose: Anti-Personnel.

Secondary Purpose: Defense.

Range: 2,000 feet (610 m).

Mega-Damage: 5D6 M.D.

Rate of Fire: Each single blast counts as one melee action/attack.

Payload: Effectively unlimited.

4. Hand to Hand Combat: Rather than use a weapon, the pilot can engage in Mega-Damage hand to hand combat as per Robot P.S. 40. See *Heavy Ground Robot Training* on page 352 of **Rifts® Ultimate Edition** for the number of attacks and bonuses. All abilities are the same except as follows.

Restrained Punch: 1D4 M.D.

Full Strength Punch: 2D6 M.D.

Power Punch is not possible.

Head/Turret Butt: 1D6 M.D.

Stomp Attack: 2D4 M.D., but is only effective against targets smaller than 13 feet (4 m) tall.

Leaps and Kicks are not possible.

5. Sensor System Notes: All standard robot systems, plus the following:

A. Recessed sensors (4 in the head turret).

B. Chest spotlight located near the right shoulder, can swivel to the right and left 180 degrees, and up and down in a 90 degree arc. Range is 2,000 feet (610 m).

C. Four old-style cooling vent tubes in the back, two pointing up, two pointing down.

NG-V7 Hunter Mobile Gun, Block IV Upgrade

The Hunter Mobile Gun remains one of Northern Gun's most famous and popular robots. And though the days when a single Hunter unit could shift the local balance of power may be gone, the NG-V7 is still a highly capable combat system that can trounce power armor, sweep aside infantry and go toe-to-toe with much more modern robots and armored vehicles. Its primary weapon system, the massive rail gun that led to the robot's name, can be brought to bear with remarkable speed by a skilled crew, using the movement of the turret and the robot's body orientation together to shift fluidly from one target to the next. This arrangement makes the Hunter a competitor even on today's battlefield, and the **Hunter Mobile Gun Block IV**, unveiled in 108 P.A., features a series of upgrades, increased armor and alternate weapons that promise to extend the service life of the robot well into the future.

The Hunter Block IV uses the same basic body frame, design and weapons as the original Block I and subsequent Block II and III production models. One can tell at a glance that the Block IV is the venerable *Hunter Mobile Gun*. However, a longer look reveals a number of subtle differences, including slight changes in the body styling that allow for increased M.D.C. armor, larger and different feet, and modular weapon features that offer a selection of different weapon systems to give the Hunter greater versatility than the original NG-V7. Other 'improvements' include a light chest gun and better optical sensor array, and a backup sensor cluster to eliminate the famous blind spot. Most of these features are barely noticeable by just looking at the redesigned Hunter Block IV. In fact, people not very familiar with combat vehicles cannot tell the difference between the earlier model blocks and the Block IV, but each new variation improves upon the performance of an already tried and true combat robot. Crews familiar with the Hunter are happy to find the Block IV handles exactly the same, but with the benefit of new and different modular weapon options (if desired), superior armor and a better optics and sensors package.

The NG-V7 Block IV represents the most dramatic change and enhancements the Hunter Mobile Gun has seen since its inception. (The Block III had 10% more M.D.C.) And customers

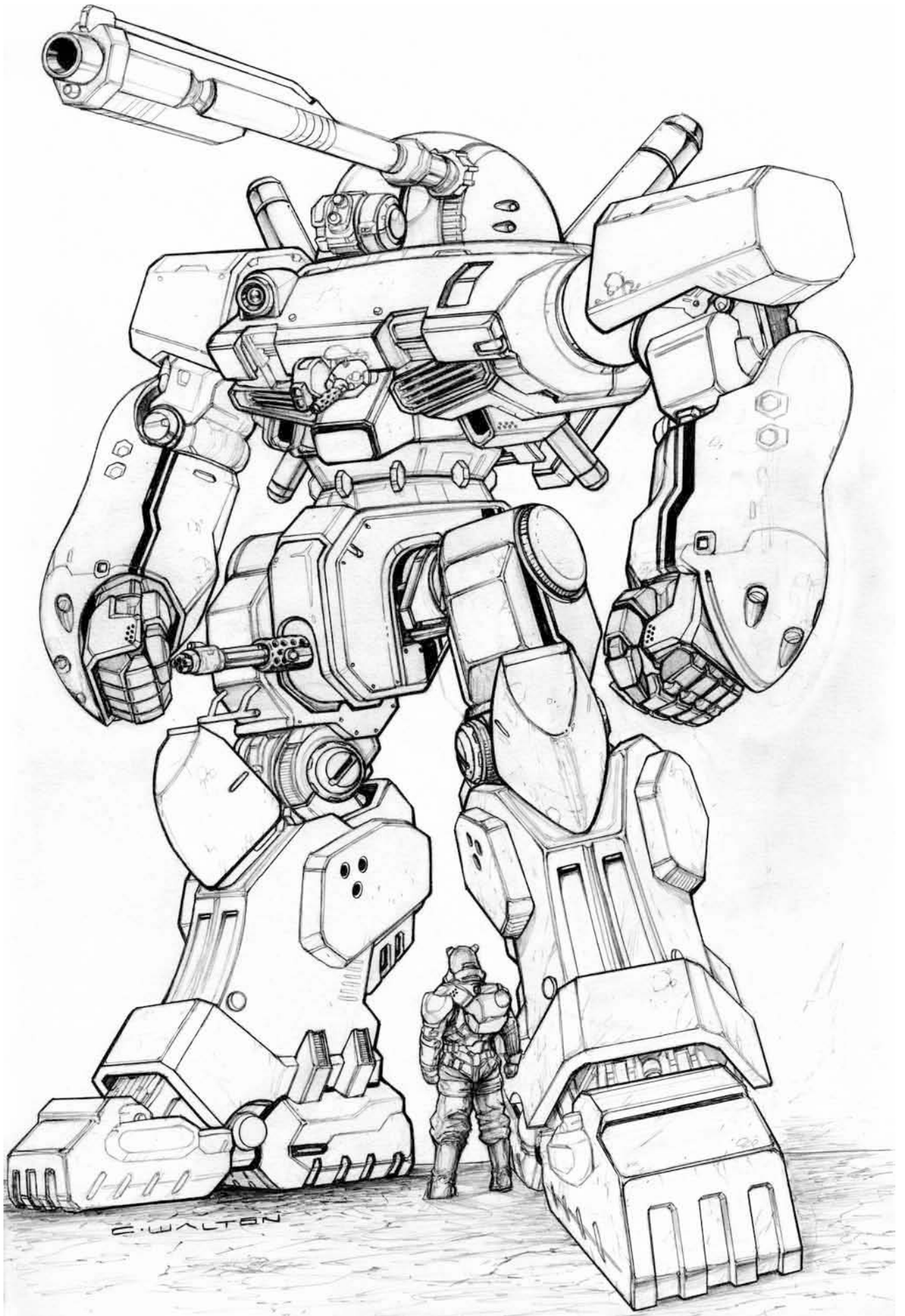

are loving it. The Block IV has received rave reviews with comments like, "Improving upon perfection." "More armor protection. The same performance value. Who wouldn't want one?" and "A well conceived upgrade to an old favorite." The Block IV is the product of the design team lead by Charles Walton, Matthew Clements and Sam Beedah.

Hunter Mobile Gun Assault Robot

Model Type: NG-V7, Block IV.

Class: Infantry Assault Robot Vehicle.

Crew: Three: One pilot, one copilot and one gunner. There is seating for two passengers but that makes for cramped quarters.

Note: The controls are designed so that the pilot can handle all functions if necessary, but it is most effective when weapon systems are divided between the pilot and a dedicated gunner, with the copilot handling communications and sensor information. The pilot typically operates the smaller weapon turrets and mini-missiles, and the gunner fires the Main Turret and sometimes the 'Crotch Cannon.'

M.D.C. by Location NG-V7 Block IV:

- Upper Arms (2) – 150 each
- Forearms with Rocket Launchers (2) – 190 each
- Hands (2) – 60 each
- Legs (2) – 250 each
- Feet (2) – 200 each
- Head/Rail Gun Turret (1) – 200
- * Sensor Drum (1; top turret) – 35
- * Sensors Eyes (4; in turret) – 5 each
- * Chest Gun (1; small) – 25
- * Chest Spotlight (1; chest, right side) – 10
- * Chest Secondary Sensor Pod (1; next to gun) – 12
- * Belly Gun (1) – 50
- Vent Tubes (2, small) – 20 each
- Vent Tubes (2, large, top) – 40 each
- ** Main Access Hatch (1; chest) – 100
- Emergency Hatch (1; top, rear) – 100
- Reinforced Pilot Compartment – 120
- *** Main Body – 600

* A single asterisk indicates a small and difficult target to strike, requiring the attacker to make a *Called Shot*, but even then the attacker is -4 to strike.

Destroying all four of the sensors mounted in the gun turret has no serious impact as they are now part of a larger sensor package. Even destroying the Main Sensor Drum on the gun turret only inflicts a -5% penalty on the Sensory Equipment skill, reduces the number of targets that can be tracked from 96 to 48, and reduces radar range by 20%. An attacker must now destroy all the sensor systems to knock out the radar and targeting system (which results in no bonuses to strike, parry or dodge and the pilot must rely on his own human vision). **Note:** The four original sensor eyes are small and difficult to hit, especially on a moving target. And even the main sensor pod on the top turret and chest sensor cluster are small enough to require an attacker to make a *Called Shot* and even then he is -3 to strike.

** Depleting the M.D.C. of the hatch makes the robot vulnerable to entry by the enemy. The inner hatch has only 20 M.D.C.

*** Depleting the M.D.C. of the main body shuts the robot down completely, rendering it useless. **Note:** The chest spotlight is destroyed when the main body has suffered 450 points of damage.

Speed:

Running: 70 mph (112 km) maximum. The act of running does NOT tire the robot pilot and speed can be maintained indefinitely.

Leaping: Not recommended. Seven feet (2.1 m) high and 15 feet (4.6 m) across, double with a running start. Though the Block IV design is less top-heavy and more balanced, there is still a risk of falling when it leaps. Roll percentile for every jump/leap. 01-25% the Hunter stumbles when its feet hit the ground and falls on its face. Fall causes the Hunter Block IV to lose 1D4 melee attacks while the pilot struggles to stand the robot back up.

Water: Cannot swim, but can walk along the bottom of lakes and seas at about half its normal speed. Maximum depth tolerance is 2,500 feet (762 m).

Flying: Not possible.

Statistical Data:

Height: 32 feet (9.7 m).

Width: 18 feet (5.5 m).

Length: 13 feet (4 m).

Weight: 38 tons fully loaded.

Physical Strength: Robotic P.S. 40.

Cargo: Minimal storage space; about four feet (1.2 m).

Power System: Nuclear; average energy life is 20 years. Solid Oxide Fuel Cell and electric battery models are also available.

Cost: 56 million credits nuclear, 49 million Solid Oxide Fuel Cell and 45 million electric battery.

Weapon Systems:

1. (Option A) NG-H155 Howitzer Rail Gun: The Mobile Gun's namesake is a massive Howitzer rail gun installed in a turret where a normal humanoid robot's head would be. This placement lets the Hunter maintain a low silhouette behind cover, only exposing its weapon when firing on tanks and robots. The positioning of the big gun gives it an excellent 360 degree view of the battlefield. **Note:** The old blind spots of the earlier models of the Hunter, directly above and below the robot, have been eliminated with the optics and sensor drum located on the front of the turret, giving the Block IV the ability to look up, down and elsewhere as the big gun aims at its designated target(s). A secondary, chest optics and sensor array also functions to eliminate blind spots and keep the pilot and gunner aware of enemies in close quarters or rushing toward the Hunter.

Primary Purpose: Assault and Anti-Armor.

Secondary Purpose: Anti-Aircraft.

Range: 6,000 feet (1,828 m).

Mega-Damage: 1D6x10 M.D. per single blast (40 rounds) or 2D6x10 M.D. per double blast (rapid-firing of two full bursts at the same target).

Rate of Fire: Each single blast or burst counts as one melee action/attack.

Payload: Two 80,000 round drums; that's 2,000 single bursts per drum or 1,000 double bursts. The second drum feeds immediately after the first drum is exhausted. Reloading a drum will take about two minutes; the process is fully automated. **Note:** The traditional ammunition can be swapped out with anti-supernatural rounds. See the Gunwolf for such ammunition.

(Option B) NG-R505 Rail Cannon: Replacing the usual Howitzer with the new R505 lets the Hunter fire single shells instead of concentrated bursts, leading to more consistent overall damage, but sacrificing the H155's impressive range.

Primary Purpose: Assault/Anti-Armor.

Secondary Purpose: Anti-Fortification.

Range: 4,000 feet (1,219 m).

Mega-Damage: 2D4x10 M.D.

Rate of Fire: Each shot counts as one melee attack.

Payload: 600 shells total, contained in two oversized 505 ammo drums.

(Option C) NG-515IC Ion Cannon: Replacing the usual Howitzer with the new ion cannon lets the Hunter fire heavy energy blasts, but sacrifices the H155's impressive range.

Primary Purpose: Anti-Armor and Assault.

Secondary Purpose: Anti-Personnel and Anti-Fortifications.

Range: 4,000 feet (1,219 m).

Mega-Damage: 6D6+4 M.D. per single blast.

Rate of Fire: Single shot only.

Payload: Effectively unlimited.

2. Forearm Mini-Missile Launchers (2): Each of the Hunter Block IV's arms contains a low profile mini-missile launcher; an unchanging feature across production Blocks I-IV. Their concealed nature and large payload inside the heavily armored forearms makes the mini-missiles an effective and deadly surprise when the robot is fighting in ranged and hand to hand combat.

Primary Purpose: Anti-Armor and Anti-Missiles.

Secondary Purpose: Anti-Personnel and Defense.

Range: One mile (1.6 km).

Mega-Damage: Varies with missile type. Usually fragmentation (5D6 M.D.) or plasma (1D6x10 M.D.).

Rate of Fire: One at a time or in volleys of 2, 3, 4 or 6.

Payload: 24 total; 12 per arm.

3. (Option A) NG-333 Heavy Laser Belly Gun (1): Sometimes jokingly referred to as a 'crotch-cannon' (sales staff usually call it a 'belly gun' or 'infantry dispersal weapon'), a heavy laser is placed between the Hunter's legs to mow down ground troops trying to take advantage of the original Hunter's infamous blind spots. Note: Regardless of the weapon system selected (A, B or C), the turret rotates 180 degrees downward, forward and backwards with a straight ahead line of fire.

Primary Purpose: Anti-Personnel and Assault.

Secondary Purpose: Defense.

Range: 2,000 feet (610 m).

Mega-Damage: 5D6+3 M.D. per simultaneous triple blast.

Rate of Fire: Each triple blast counts as one melee attack.

Payload: Effectively unlimited.

(Option B) Heavy Flamethrower (1): Though limited in range, replacing the belly gun's laser with a flamethrower makes it even better suited to repelling waves of small monsters and infantry troops trying to climb aboard or fire at the Hunter from the ground at its feet. It can also be used to flush out bunkers and enemy positions, and against creatures vulnerable to or afraid of fire. Comes with valves that automatically seal it off underwater, deactivating it and preventing water from contaminating the napalm reserve.

Primary Purpose: Anti-Structure and Defense.

Secondary Purpose: Anti-Personnel and Assault.

Range: 400 feet (122 m).

Mega-Damage: 1D4x10 M.D. to the target and anyone within 10 feet (3 m).

Rate of Fire: Each burst counts as one melee action/attack.

Payload: 48 bursts. The flamethrower can be refueled with military-grade napalm or use normal diesel or gasoline (reduces damage to 3D6 M.D.). 80 gallon (302 liter) fuel reserve.

(Option C) Medium NG-223 Chest Rail Gun (1): A medium rail gun is used against ground targets and on opponents while grappling or locked in hand to hand combat. Like all rail guns, it can fire conventional rail gun rounds or silver-coated rounds or wood and silver rounds (see Gunwolf for details) to battle the supernatural.

Primary Purpose: Assault & Anti-Personnel.

Secondary Purpose: Defense.

Range: Conventional rail gun rounds and silver coated rounds: 2,000 feet (610 m). Special, weighted wood rounds with silver rings: 1,000 feet (305 m).

Mega-Damage: Varies. Standard & Silver Ammo: A standard M.D. burst is 60 rounds and inflicts 5D6 M.D. (+4 M.D. to opponents at point-blank range; within 10 feet/3 m) per burst. One round does 1-2 M.D.

Rate of Fire: Each single shot or burst counts as one melee attack.

Payload: 6,000 rounds total with enough ammo for 100 bursts.

4. NG-133 Light Laser Chest Gun: A light laser turret has been added to the Block IV's defenses. It is intended to protect the secondary optical sensor pod in the chest and to disperse enemy troops who get too close for comfort. The small turret can rotate 90 degrees up and down, and has a forward sweep, side to side, of 45 degrees.

Primary Purpose: Anti-Personnel and Assault.

Secondary Purpose: Defense.

Range: 2,000 feet (610 m).

Mega-Damage: 2D6 per single blast.

Rate of Fire: Each blast counts as one melee attack.

Payload: Effectively unlimited.

5. Hand to Hand Combat: Rather than use a weapon, the pilot can engage in Mega-Damage hand to hand combat as per Robot P.S. 40. See *Heavy Ground Robot Training* on page 352 of **Rifts® Ultimate Edition** for the number of attacks and bonuses.

6. Sensory System: The Hunter Block IV has all the standard robot features, and a backup sensor array built into its chest, plus the following:

A. Enhanced radar via the main sensor drum, can I.D. and track 96 targets. If the Main Sensor Drum is destroyed, that number drops to 48.

B. Recessed sensors (4 in the head turret) and a secondary sensor package in the chest.

C. Chest spotlight located near the right shoulder, can swivel to the right and left 180 degrees, and up and down in a 90 degree arc. Range is 1,500 feet (457 m).

D. Four old-style cooling vent tubes in the back, two pointing up, two pointing down.

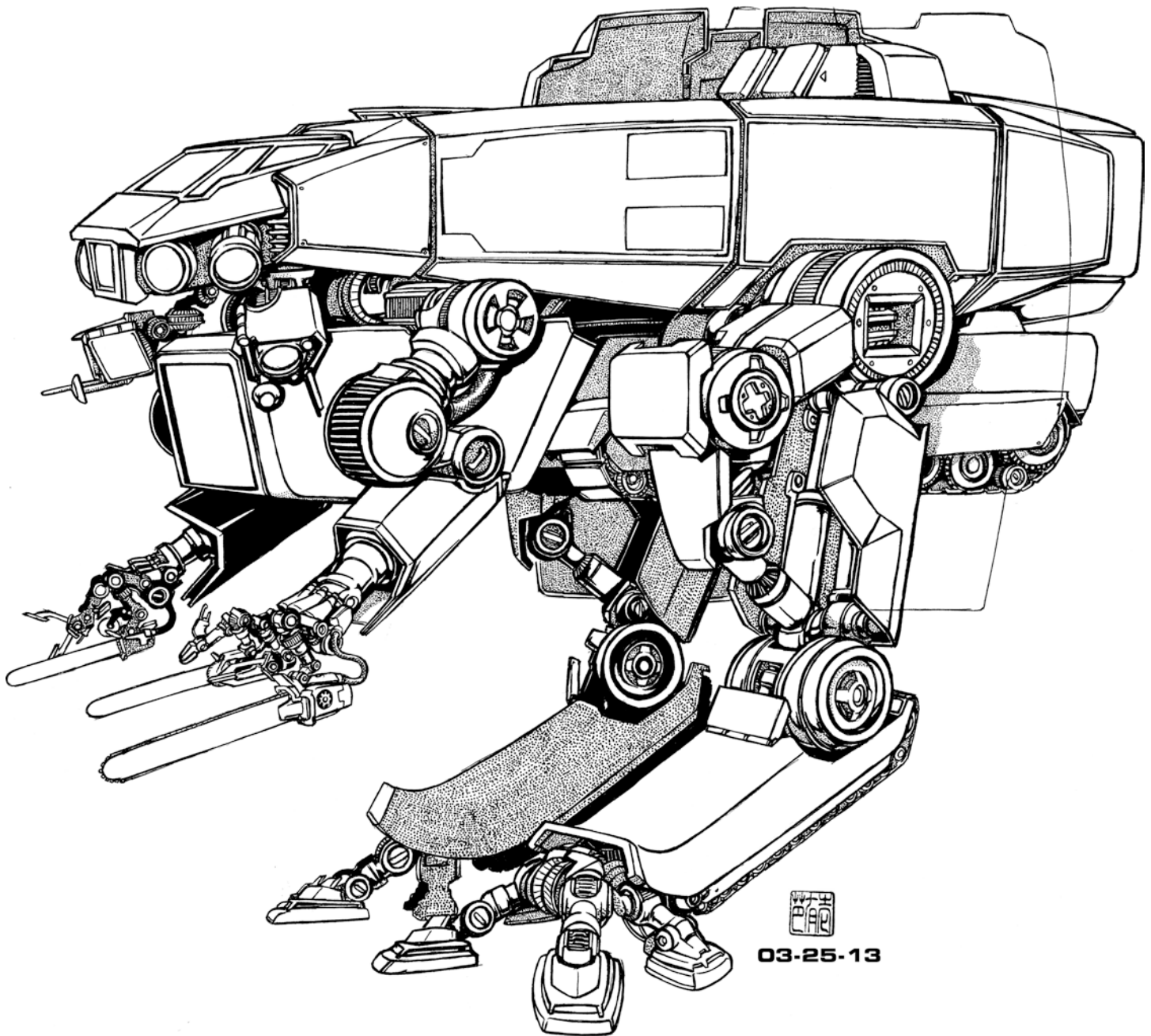

MMB-01 'Big Papa' Mobile Medical Robot

The Mobile Medical Robot is the brainchild of the Gleba design team of **Matthew Wood, Christopher Wilmer, Jeremy D. Helton, Carl Gleba, Benjamin Rodriguez, and Sam Beedah**. It was originally designed with the idea of being a part of a medical field team. The design team asked the question, "What is the most important aspect of any robot, power armor, or mechanized weapon?" The answer, "Its pilot." And when a pilot's robot or combat vehicle is destroyed (reduced to zero or less Main Body M.D.C.), that pilot or combat crew may be trapped with the wreckage and/or in need of medical assistance. To rescue robot pilots, they came up with the idea for the MMB-01. Only as they worked on the robot, and built in design elements to pry open hatches and cut robot pilots out of a dead robot, they were actually creating a much more versatile, first-responder, rescue ro-

bot. And as such, the MMB-01 has proven to be one of Northern Gun's hottest selling new robots.

The MMB-01 Mobile Medical Robot, also known as *Big Papa* (because there is also a smaller version known as *Junior*), is a large, manned, all-terrain medical robot that functions as a small, mobile hospital. Inside is a medical team and 16 beds for patients. If magic, psychic healing or medical nano-bot systems are used (the latter is most common among technological people), two-thirds of injuries can be addressed in the field, with the patient being released back into active duty within 10-30 minutes. Only the most severe of injuries require the patient to be stabilized and kept for long-term care or to be medevaced to a hospital for more extensive surgery or treatment.

Big Papa and Junior are both capable of field diagnosis with a 96% accuracy rate, surgery and rescue operations, with the latter including pulling pilots and crews out of the wreckage of combat vehicles as well as digging people out from under debris and collapsed buildings. In many situations, able-bodied combatants can be freed from their dead robot or the debris that has them

pinned in a matter of minutes. Immediate medical aid can be administered to the injured via a wide range of nano-medical systems even *before* the rescue is completed! Wounds can be sutured closed, bleeding stopped, internal injury fixed and other physical repairs initiated via tiny nano-medical robots. If the person can be touched by one of the robot's fingers or a remote delivery system (a tiny robot the size of a field mouse, but more resembles a mechanical bug), the appropriate combination of nanobot systems can be put to work. This is done while the trapped individuals are waiting to be liberated or rescued.

To make such efforts possible in most environments, the MMB-01 has treads and vehicular locomotion for quick response and extraction. Additionally, the treads provide a smoother ride which may be called for if delicate medical procedures are being performed. However, when needed, a pair of legs unfold to enable the robot to walk and negotiate uneven surfaces, climb over debris, go up and down inclines/stairs, walk through water, and maneuver in environments unsuitable for a vehicle. The legs also enable the MMB-01 to rise up to reach crewmen trapped inside robots that may become inoperable but remain standing, and to reach people trapped on floors above ground level and low rooftops. (Maximum elevation of the legs while keeping the main body level is 66 feet/20 m or roughly six stories. Add another 20 feet/6.1 m if the main body is tilted at an angle. However, the hydraulic arms can reach another 45 feet/13.7 m upward. The legs are not made for running or leaping, but rather to reach people in need of rescuing in a range of different environments.

The MMB-01 Big Papa (and to a lesser degree, the MMB-02 Junior) functions as a mobile medical combat clinic and medical transport that quickly addresses minor injuries and keeps the seriously injured patients stable. Those requiring extraction from hot zones to fully equipped field hospitals are placed in secure, automated med-beds that are stacked like rows of bunk-beds three tall. Each holds the patient securely, administers proper medication, blood/plasma, nutrients and oxygen (as needed), keeps the patient stabilized, and monitors vital statistics (heart rate, respiration, blood pressure, etc.). When all beds are full, or the crew is given orders to evacuate the patients, the Mobile Medical Robot folds up its legs, sets down on its tank treads and zooms away to the nearest medical facility or designated extraction point. In the field, the wounded are most likely to be extracted via hover ground vehicle, helicopter, magic, or other suitable means. As soon as the patients are whisked away, the MMB-01 returns to the field to minister to more combat injuries.

The two MMB series robots have proven equally adept at emergency response and rescue of people from burning buildings and collapsed structures. However, it is important to note that Big Papa and Junior are designed as field clinics for combat injury and physical trauma. This means their medical teams and built-in capabilities are oriented toward rescue and the tending to cuts, burns and wounds, setting bones, surgery, and injuries resulting from war or physical injury, not disease control or forensics, nor chemical analysis or scientific research.

The main body of the Mobile Medical Robot is boxy and elongated. In fact, the big robot is reminiscent of the old **EX-5 Behemoth Explorer**, especially when standing on both legs. When riding on the street, through fields, grasslands and deserts, the treads are used. When the terrain is too uneven or requires a humanoid range of mobility, a pair of large, oversized legs and feet

unfold. The legs and feet are designed for maximum stability to support the robot. Maximum standing height is 66 feet (20 m).

The arms are also designed to fold up tight and small, and unfold as needed. The two large arms have hydraulic and telescoping capabilities that enable them to extend up to 45 feet (13.7 m). Each can rotate 360 degrees at the shoulder, and at the elbow. The fingers are actually a variety of tools used for cutting, excavation and extracting combat pilots from the wreckage of vehicles and people trapped under debris or collapsed buildings.

On each hand, two fingers have specialized cutting tools that extend from the fingers when needed. One is a saw for cutting anything from M.D.C. metals to wood and concrete. Another tool is the modern-day equivalent of the Jaws of Life, used to pry open M.D.C. hatches, tear through metal and mortar, or widen holes. All fingers have a built-in camera and light to enable the pilot and medical crew to see wherever it points (200 foot/60 m range). Each finger also has a bio-comp system to scan the vitals of any person it touches. Likewise, if an injured person can be touched by the finger, medical nano-bots can be released to tend to injuries and stabilize him. All visual and biological information is immediately relayed to the crew and medical team inside the robot. It can also be transmitted to a mobile base or nearby hospital within 100 miles (160 km) of the MMB-01, or any group monitoring or supervising the rescue operation. A Jaws of Life and chainsaw, as well as cutting laser and surgical laser, are all standard equipment built into the fingers. When a patient cannot be reached by the arms, but can be seen or heard in the distance, the Mobile Medical Robot can release one or more RMDR-NM12 Remote Medical Delivery Robots. These are small robots the size of a field mouse that scurry along on spider-like legs to administer the designated medical nano-robots to begin medical treatment and repairs.

The MMB is not meant as a front-line fighter and as such, has a light weapons load. Optimally the MMB is protected by a small company of defenders. Some MMBs used in cities or rural areas that are relatively protected often forgo the weapons to save on costs. Instead, water tanks tend to be added and the unit doubles as a fire-fighting rig.

The MMB has four different sections. The top floor/section is the medical bay and there is a rooftop bay that opens for airlift extraction of patients via helicopter, power armor, hover vehicles or other air-based means. The rear lower deck contains the living quarters for the medical staff plus a small kitchen and communal shower and three toilets and sinks. The front section, where the spotlights are located, is the cockpit/crew compartment and where many of the robot's features can be accessed. The box-like compartment under the cockpit is medical supply storage, which could be used to add more beds or transport the wounded if needed, but the supplies would have to be 'dumped' to make room and the ride is uncomfortable.

Northern Gun has found it has a monopoly on medical robots. Kingdoms, city states, mercenary companies and even adventurers and explorers who can afford one, are happy to do so and are willing to wait months for their order. While the wait is inconvenient, Northern Gun will customize the robot with a specific paint scheme to match the local kingdoms protectors or fire and rescue team. The instant success of the Mobile Medical Robots has many military companies and communities believing they are not complete unless they have at least one MMB-01 Mobile Medical Robot (or a couple of the smaller MMB-02s). Likewise,

adventurers and heroes have found Big Papa and Junior to be decent exploration robots and a valued resource when a teammate is injured or becomes ill hundreds of miles away from the nearest medical facility, and when swept away to an alien world by a Rift or magic. Both Big Papa and Junior are hot commodities which makes keeping them in stock difficult at best. Poor availability.

Model Type: NG MMB-01

Class: Mobile Medical Field Unit & Rescue.

Nickname: Big Papa.

Crew: The top, forward section is the pilot compartment and seats the Robot Pilot, copilot/communications specialist and one Body Doc or other medical personnel to serve as an advisor. In the alternative, the medical advisor could be replaced with an Operator, engineer or excavation and rescue specialist. The pilot or copilot manipulates the arms.

Onboard Medical Team: 6-12; the optimal medical team is 2-4 skilled doctors (Body Fixers or other type of doctor or Psychic Healer) and 6-8 medical assistants (nurses, paramedics, psychics, mage with healing powers, etc.). One member of this team is often an Operator or mechanical engineer to deal with mechanical and structural concerns in rescue operations.

Patient Capacity: 18 beds. Inside the body of the 72 foot (22 m) long robot are four examination areas that also serve as operating rooms, a dispensary, and sick bay with 18 automated med-beds. But triple that number of patients can be transported sitting and laying on the floor, and standing wherever there is room. Under the floor is additional storage for medical supplies and nano-medical systems.

M.D.C. by Location:

- Spotlights (4, head) – 15 each
- Upper Arms/Shoulders (2) – 150 each
- Forearms (2) – 150 each
- * Utility Hands (2) – 100 each
- * Utility Hand: Pry Bar/Jaws of Life (1 pair per hand) – 100 each
- * Utility Hand: Chainsaw (1 per hand) – 75 each
- ** Utility Hand: Fingers (4 per hand, folding) – 25 each
- ** Folding Sensor ‘Arms’ (2) – 30 each
- ** Folding Arm: Thermal Array (1, small, right) – 45
- ** Folding Arm: Spotlight Array (1, small) – 45
- * Mini-Missile Launcher (1, nose, between spotlights) – 150
- Upper Legs (2) – 250 each
- Lower Legs (2) – 275 each
- Feet (2) – 150 each
- * Treads (2, underneath the main body) – 140 each
- * Rear Hatch (1, large) – 150
- * Top Hatch (1, large) – 200
- * Concealed Side Panels for Tenting (2 per side) – 30 each
- Front Cargo Bay (1, chest) – 200
- Reinforced Pilot Compartment – 100
- *** Main Body – 580

* A single asterisk indicates a small and difficult target to strike, requiring the attacker to make a “Called Shot,” but even then the attacker is -3 to strike.

** Two asterisks indicates a very small and moving, or extremely difficult target to strike. It requires the attacker to make a “Called Shot” with a penalty of -5 to strike.

*** Depleting the M.D.C. of the main body shuts the vehicle down completely, making it useless. All hatches can be opened by hand.

Speed:

Treads: 55 mph (88 km) in vehicle mode.

Running: 20 mph (32 km) maximum using legs.

Leaping: Not possible.

Water: Fair to poor, the MMB-01 is able to walk along the bottom of a body of water at 10 mph (16 km). Maximum depth is 1,200 feet (366 m).

Flying: Not possible.

Statistical Data:

Height: Variable. 20 feet (6.1 m) in vehicle form and legs retracted to a stowed position. Up to 66 feet (20 m) walking or standing on legs. 86 feet (26.2 m) when the forward section of the MMB-01 is tilted upward and legs are at maximum extension.

Width: 28 feet (8.5 m).

Length: Body: 72 feet (22 m). Maximum Length/Reach of Main Arms: 45 feet (13.7 m). Length/Reach of Smaller, Folding Arms: 40 feet (12.2 m).

Weight: 25 tons.

Physical Strength: Robot P.S. of 40, overall. P.S. 50 for Jaws of Life.

Cargo: 20 foot (6.1 m) storage area (chest) with a 160 ton limit. Typically contains medical supplies and gear, folding tables, portable field equipment, 1D4 portable generators, and similar.

Power System: NGV8 Nuclear power core with enough fuel to last 12 years. Cannot use alternative power supplies.

Cost: 132 million credits new with full medical gear. High demand, poor availability.

Weapon Systems:

1. NG-A48 Mini-Missile Launcher: Mounted just under the pilot compartment, in the nose, is a box mini-missile launcher. It can rotate 90 degrees left or right as well as 45 degrees up or down.

Primary Purpose: Defense.

Range: One mile (1.6 km).

Mega-Damage: Any type of mini-missile can be used, but standard issue is fragmentation, anti-personnel missiles (5D6 M.D.).

Rate of Fire: One at a time or in volleys of two, three or four. Firing a single mini-missile or a volley of 2-4 counts as one melee attack.

Payload: 48, but as a rule, an additional 48 are stored in the cargo hold. It takes 1D4+1 minutes for a trained crewman to reload; add six minutes for the untrained.

2. Large Utility Arms & Jaws of Life (2): There are two arms with multi-purpose utility hands containing a wide array of lifesaving features. Each finger folds to be concealed when not in use, and has 25 M.D.C.; Jaws of Life and chainsaw have more M.D.C. Attackers must make a Called Shot to hit, and even then they are -5 to strike.

a) Large Pry Bar/Jaws of Life Apparatus: The Jaws of Life are used for prying open hatches and doors, enlarging holes in metal hulls to make them large enough for people to squeeze through, ripping through wreckage to find people who may be inside, moving rubble and debris, and for lifting out the injured. When not in use, the tong-like Jaws of Life are pressed together (like human hands in a prayer position), creating the illusion there is only one pry bar. In reality, there

are two. Standard use is to force the pry bars into the crease of a door or hatch and spread the two bars apart to force the hatch open. The same technique is used to create larger openings in damaged hulls/walls.

Primary Purpose: Rescue and Forced Entry.

Secondary Purpose: Anti-Fortification.

Range: Touch/close combat.

Mega-Damage: The pry bar/Jaws of Life has a Robotic pry/tear strength of 50 and inflicts 3D6+6 M.D. when they are used to spread openings and otherwise pry open doors/hatches or tearing through debris and hulls (not applicable to punches). Despite the strength of the Jaws of Life, the pilot can control them to lift and move the injured very gently.

Payload: Effectively unlimited.

b) M.D. Chainsaw (1 per hand): Each hand has a five foot (1.5 m) long chainsaw blade for cutting through M.D.C. doors, hulls, walls, and collapsed structures to free people who are trapped and injured. When not needed, the tool folds back and slides behind the hand to stow inside a forearm housing. It takes two melee actions to extend the chainsaw or to put it in its stowed position.

Primary Purpose: Rescue and Cutting through wreckage/debris.

Secondary Purpose: Anti-Fortification, Sabotage and Defense.

Range: Touch/close combat.

Mega-Damage: The chainsaw does 5D6 M.D. per attack, and even when turned off, it does 1D4 M.D. as a blade weapon plus Robot P.S. punch damage for slashing attacks. **Note:** The chainsaw is a modular unit that can be easily replaced with a chainsaw that has *silver sawteeth* to battle supernatural beings vulnerable to silver. The problem is that the silver plating is destroyed after 2D4 uses against M.D.C. armor, so it is best to swap out the chainsaw unit on an as needed basis depending on the anticipated opposition.

Payload: Effectively unlimited.

c) Laser Torch (1 per hand): The utility hand has a finger that is a precision cutting device for slicing through debris to free the trapped and injured. It can fold up when not in use. Point and fire.

Primary Purpose: Cutting and Rescue.

Secondary Purpose: Defense.

Range: 40 feet (12.2 m).

Mega-Damage: All of the following settings are available: 3D6 S.D.C., 5D6 S.D.C., 1D6x10 S.D.C., 1 M.D., 1D4 M.D. and 2D4 M.D.

Rate of Fire: Each blast counts as one melee attack/action.

Payload: Effectively unlimited.

d) Laser Scalpel (1 per hand): Mounted on the Laser Torch finger is a smaller laser used for delicate cutting, repairs and actual field surgery. Ideal for soldering, cutting away objects and wire, removing limbs and cauterizing wounds. Point and fire. Folds back when not in use.

Primary Purpose: Cutting and Rescue.

Secondary Purpose: Defense.

Range: 12 feet (3.6 m).

Mega-Damage: All of the following settings are available: 1 S.D.C., 1D4 S.D.C., 2D4 S.D.C. and 4D4 S.D.C.

Rate of Fire: Each blast counts as one melee attack/action.

Payload: Effectively unlimited.

e) Clamp Finger (1 per hand): This two-finger apparatus is used to clamp and tear away (Robotic P.S. 40), grip and hold

or grip and lift objects or the patient. When not needed, it folds up and tucks back behind the palm.

f) S.D.C. Cutting Tool (1 per hand): This is a comparatively small, circular blade the size of a dinner plate. It is a precision cutter use to remove clothing and cut through light S.D.C. material.

Primary Purpose: Rescue and Cutting.

Range: Melee combat.

Mega-Damage: Not applicable; does 1 S.D.C., 1D4 S.D.C. or 2D4 S.D.C.

Payload: Effectively unlimited.

Note: Each finger has an infrared and conventional light beam (200 foot/61 m range) and digital video camera that feeds directly into the crew compartment. Live feed can be relayed to the medical crew as well. This enables the team to find victims trapped in debris, assess damage and conditions, and see into narrow places.

3. Hand to Hand Combat: Rather than use a weapon, the pilot can engage in Mega-Damage hand to hand combat as per Robot P.S. 40. However, the Mobile Medical Robot is NOT designed for fighting. See *Heavy Ground Robot Training* on page 352 of **Rifts® Ultimate Edition**, but reduce the number of attacks and bonuses by half, round down.

4. Sensor Systems and Other Features of Note: In addition to those common to all robot vehicles, the MMB-01 has the following:

A. Sensor Arm with Thermal Imager and Display Screen

(1, right): A special acoustic array and optical heat sensor are built into this the right, folding arm. It also has a video camera and laser distancer. *The acoustic array* picks up and amplifies sound in the same way as the bionic Ultra-Ear, for the purpose of identifying sounds of life and locating victims trapped inside wreckage and collapsed buildings. *The infrared radiation* of warm objects can be detected and converted into a visible image. This enables the Big Papa pilot and rescue team to see in the dark, in shadows and through smoke and dust, as well as pinpoint heat signatures behind S.D.C. walls, thin M.D.C. material (one inch or less) and loose earth and dust to recover survivors.

A flat, display screen is also a vital feature of this arm. The screen can flip up when not needed, and down to display data. It is used to show trapped victims images, diagrams and live video messages from the rescue team. This is used mainly by the communications officer and medical team to communicate directly with people trapped in wreckage. Seeing a friendly face, even one on a video screen, talking calmly and explaining the situation is extremely comforting, reassuring and soothing. This simple feature calms those in panic situations and can actually lower blood pressure, reduce anxiety, and gather potentially helpful and situational data. The screen can also be used to display diagrams, plans and information to the victims as well as members of the rescue team and field personnel regarding excavation and recovery, medical procedures and mechanical and/or electrical schematics. In a pinch, it can also be used to display a silent, visual message. The monitor does have a mic and speakers for two-way communication.

The arm can extend 40 feet (12.2 m), as well as rotate 360 degrees at the shoulder mounting and at the flat screen located at the end of the arm. The arm is thin and flexible with 30 M.D.C., the acoustic array has 12 M.D.C., the thermal imag-

ing sensor wand has 8 M.D.C., and the monitor has 6 M.D.C. All require a Called Shot to be hit by an enemy, and the shooter does so with a penalty of -5 to strike.

B. Multi-Purpose Searchlight Arm (1, left): Mounted under the two spotlights, on the left side of the nose, is an extendible, folding arm. It contains a video camera, a laser distancer, a secondary sensor array, communications system and a searchlight. The arm can extend 40 feet (12.2 m), as well as rotate 360 degrees at the shoulder mounting and at the sensor box mounting at the end of the arm. The arm is thin and flexible (30 M.D.C.; and the sensor box where the light and camera are located has 35 M.D.C.). Obviously, the arm serves several functions, not the least of which is to position itself to provide superior lighting for search and rescue operations, surgery and investigation. The light beam has a maximum range of 3,000 feet (914 m). The long-range, directional radio that is part of this unit has a range of 500 miles (805 km) and scrambling and relay capabilities.

C. Thermal Imager: Perfect for seeing through smoke and can help to find victims caught in a fire or on a smoky battlefield. Range: 1,800 feet (548.6 m).

D. Finger Multi-Medical Scan System and Cameras: Built into each finger is a medical scanner that can detect and transmit the vitals of anyone it touches (or of whom it comes within three feet/0.9 m). It provides respiration, heart rate, blood pressure, body temperature, EKG and EEG data, and similar bio-stats. The finger also has a concealed laser distancer (2,000 foot/610 m range), light and digital camera (the latter two have a 200 foot/61 m range) with macro lens for close detail and magnification (x10) to relay visual information. All this data gives the medical team a +10% bonus in diagnosing the severity of the injuries and assessing the person's condition.

E. Field Hospital Clinic: The MMB-01 functions as a mobile field hospital with a full medical team inside the robot. When it is necessary to expand the capabilities of the medical facility, the robot goes into vehicle mode and tarps can be removed from compartments on the sides of the MMB-01 to create additional, tent-like awnings with drop down mosquito netting for the sides of the enclosure. This provides a temporary shelter for additional wounded that is 18 feet (5.5 m) by 8 feet (5.5 m) in size. Folding tables, also stowed in the side compartments, can be used as surgical tables and work places for emergency field surgery and care. Moreover, there are outlets and power hook-ups in these side compartments where additional medical equipment and lights can be plugged in for use. All such items are usually part of the MMB-01's standard cargo.

F. Automated med-beds (18): Each holds the patient securely, administers proper medication, blood/plasma, nutrients and oxygen (as needed), keeps the patient stabilized, and monitors vital statistics (heart rate, respiration, blood pressure, etc.).

G. Nano-Robot Medical Systems: 36 of each, minimum. Many have two or three times that number. Thirty-six of each comes standard with the MMB-01.

IRMSS Internal Robot Medical Surgeon System: An amazing medical device that injects a dozen microscopic robot units, about the size of a pinpoint, into the bloodstream to repair internal injury. The containment unit is placed over or near the suspected area of damage and the depression of a but-

ton releases the micro-surgeons into the body. The tiny robots search for the damage and repair it. Types of internal injury which they can repair include the removal of blood clots, repairing torn/ruptured veins, internal bleeding, and minor damage to internal organs. Equal to a medical doctor's surgical skill of 75%. When the units are done, they simply turn off and are naturally flushed from the body (average life is one hour). They are not reusable. Each IRMSS holds 48 surgical robots for four uses. Cost: 42,000 credits for each IRMSS kit.

IROU Internal Robot Oxygen Unit or 'Breather': This is the largest of the internal robots although still quite small. The 'bot resembles a caterpillar, because it is long and narrow and has many tiny legs. It can enter the body through the mouth or a tracheotomy in the throat. It crawls through the narrow passage with a pair of thin, narrow plastic tubes trailing behind it. As the 'bot makes its way towards the lungs it can transmit video images and data about damage to the throat. Once in the lungs, it transmits data and video images of damage and does analysis. A tiny molecular analyzer is used to identify toxins, drugs and foreign agents. Respiration is also monitored. The video pictures enable the doctors to accurately assess problems and determine the most appropriate treatment without surgery. One of the tubes is hooked up to an external device to extract fluids in the lungs and the other supplies oxygen. The Breather can also release a half dozen IRMSS 'bots to repair small holes and perform minor surgery. Cost: 50,000 credits each.

IRVT Internal Robot Visual Transmitters or 'Seekers': This is another nano-bot about the size of a pinhead. It is injected into the vein of a patient and goes traveling through the circulatory system. It is tracked and monitored via a homing device. The 'bot transmits a more powerful signal and video image of obstructions and damage to the veins and arteries as they are encountered. It is used primarily to locate blocked, pinched and damaged arteries, veins, and other internal passageways. Cost: 80,000 credits per unit – disposable (less than 33% can be safely retrieved, thus they harmlessly disintegrate inside the body after about 72 hours).

RAU Robot Antiseptic Units or 'Cleaners': A cleaner is a tiny robot roughly three inches (76 mm) long and one inch (25 mm) in diameter. They are reminiscent of a mechanical beetle that gently crawls along a wound or infected area destroying infection, removing pus and dead flesh, while cleaning the wound and spraying it with antiseptic protein for faster healing. The cleaners are usually sold and dispatched in pairs. Cost: 50,000 credits per pair.

RMK Robot Medical Kit or 'Knitter': A unique medical kit, developed with the mastery of nano-technology, in which a half dozen tiny robots, about the size of a shirt button, are released and automatically seek out cuts in the skin. One sprays the wound with disinfectant, another sprays antibiotics, a third cuts away dead or infected flesh, while the other three surgically suture the cut closed. When the cut is repaired, the tiny 'bots return to their carrying unit, refill their supplies and wait till activated again. Equal to a paramedic suturing skill of 90%. Not effective against internal injury, broken bone, or severe wounds. But great for cuts, bruises, bullet and stab wounds. Cost: 24,000 credits each.

RSU Robot Sedative Units or 'Sleepers': Four tiny robots, each the size of a pinhead, enter the brain and stimulate

certain areas to make the patient relax and feel drowsy. The calming effect of these nano-bots causes the patient to breathe slow, even breaths, keeps the pulse rate steady and calm, and helps maintain normal blood pressure. When they are done the 'bots return to a tiny housing device. Cost: 100,000 credits per set of four.

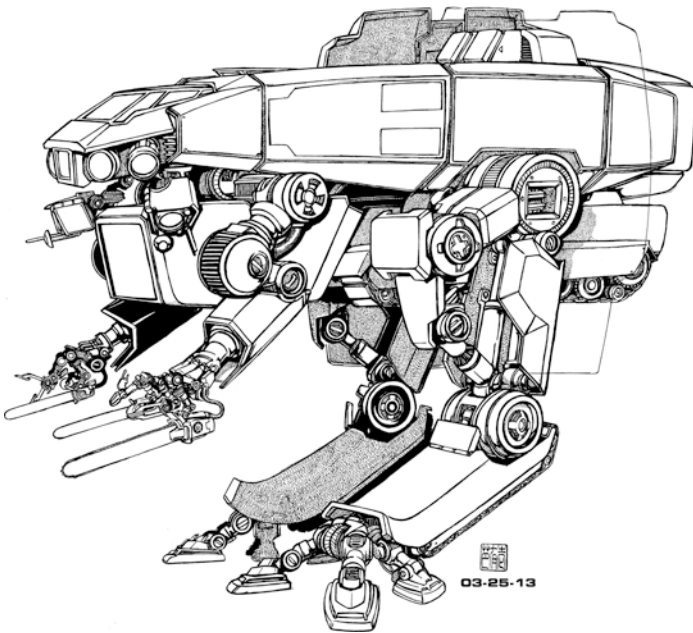

MMB-02 'Junior'

Mini-Mobile

Medical Robot

The MMB-02 'Junior' Mobile Medical Robot is exactly what the name suggests, a much smaller version of the MMB-01. Junior is identical to the Big Papa in appearance and function, it is just smaller, accommodates fewer patients and has less available resources.

Model Type: NG Mini-MMB-02

Class: Mobile Medical Field Unit & Rescue.

Nickname: Junior.

Crew: Three. The top, forward section is the pilot compartment and seats the Robot Pilot, copilot/communications specialist and one Body Doc or other medical personnel to serve as an advisor. In the alternative, the medical advisor could be replaced with an engineer or excavation and rescue specialist. The pilot or copilot manipulates the arms.

Onboard Medical Team: Four or five; 1-2 skilled doctors (Body Fixers or other type of doctor or Psychic Healer) and 2-3 medical assistants (nurses, paramedics, psychics, mage with healing powers, etc.). One member of this team is often an Operator or mechanical engineer to deal with mechanical and structural concerns in rescue operations.

Patient Capacity: Eight beds. Inside the body of the 29 foot (8.8 m) long robot are two examination areas that also serve as operating rooms, a small drug dispensary, and sick bay with 8 automated med-beds. But triple that number of patients can be transported sitting and laying on the floor, and standing wherever

there is room. Under the floor is additional storage for medical supplies and nano-medical systems.

M.D.C. by Location:

Spotlights (4, head) – 6 each

Upper Arms/Shoulders (2) – 100 each

Forearms (2) – 90 each

* Utility Hands (2) – 60 each

* Utility Hand: Pry Bar/Jaws of Life (2 per hand) – 30 each

* Utility Hand: Chainsaw (1 per hand) – 20 each

** Folding Sensor 'Arms' (2) – 20 each

** Folding Arm: Thermal Array (1, small, right) – 15

** Folding Arm: Spotlight Array (1, small) – 20

** Utility Hand: Fingers (4 per hand, folding) – 15 each

* Mini-Missile Launcher (1, nose, between spotlights) – 80

Upper Legs (2) – 120 each

Lower Legs (2) – 130 each

Feet (2) – 90 each

* Treads (2, underneath the main body) – 70 each

* Rear Hatch (1, large) – 90

* Top Hatch (1, large) – 100

Front Cargo Bay (1, chest) – 140

Reinforced Pilot Compartment – 100

*** Main Body – 445

* A single asterisk indicates a small and difficult target to strike, requiring the attacker to make a "Called Shot," but even then the attacker is -3 to strike.

** Two asterisks indicates a very small and moving, or extremely difficult target to strike. It requires the attacker to make a "Called Shot" with a penalty of -5 to strike.

*** Depleting the M.D.C. of the main body shuts the vehicle down completely, making it useless. All hatches can be opened by hand.

Speed:

Treads: 45 mph (72 km) in vehicle mode.

Running: 12 mph (19.2 km) maximum using legs.

Leaping: Not possible.

Water: Fair to poor, the MMB-02 is able to walk along the bottom of a body of water at 8 mph (13 km). Maximum depth is 1,000 feet (305 m).

Flying: Not possible.

Statistical Data:

Height: Variable. 13.6 feet (4.1 m) in vehicle form and legs retracted to a stowed position. Up to 35.6 feet (11 m) walking or standing on legs. 47 feet (14.3 m) when the forward section of the MMB-02 is tilted upward and legs are at maximum extension.

Width: 15 feet (4.6 m).

Length: Body: 29 feet (8.8 m). Maximum Length/Reach of Main Arms: 20 feet (6.1 m). Length/Reach of Smaller, Folding Arms: 15 feet (4.6 m).

Weight: 15 tons.

Physical Strength: Robot P.S. of 30, overall. P.S. 40 for Jaws of Life.

Cargo: 10 foot (3 m) storage area (chest) with an 35 ton limit. Typically contains medical supplies and gear, folding tables, portable field equipment, 1D4 portable generators, and similar.

Power System: NGV8 Nuclear power core with enough fuel to last 15 years, but can use alternative power supplies.

Market Cost: 70 million credits new with full medical gear. 64 million for a Solid Oxide Fuel Cell power system and 60 million credits of an electric battery. High demand, poor availability.

Weapon Systems:

1. NG-A16 Mini-Missile Launcher: Mounted just under the pilot compartment, in the nose of Junior, is a box mini-missile launcher. It can rotate 90 degrees left or right as well as 45 degrees up or down.

Primary Purpose: Defense.

Range: One mile (1.6 km).

Mega-Damage: Any type of mini-missile can be used, but standard issue is fragmentation, anti-personnel missiles (5D6 M.D.).

Rate of Fire: One at a time or in volleys of two, three or four. Firing a single mini-missile or a volley of 2-4 counts as one melee attack.

Payload: 16 total. As a rule, an additional 32 are stored in the cargo hold. It takes 1D4+1 minutes for a trained crewman to reload; add six minutes for the untrained.

2. Large Utility Arms & Jaws of Life (2): There are two arms with multi-purpose utility hands containing a wide array of lifesaving features. Each finger folds to be concealed when not in use, and has 12 M.D.C.; Jaws of Life and chainsaw have more M.D.C. Attackers must make a Called Shot to hit, and even then they are -5 to strike.

a) Large Pry Bar/Jaws of Life Apparatus: Same as the MMB-01 Big Papa Mobile Medical Robot, just smaller.

Primary Purpose: Rescue and Forced Entry.

Secondary Purpose: Anti-Fortification.

Range: Touch/close combat.

Mega-Damage: The pry bar/Jaws of Life has a Robotic pry/tear strength of 40 and inflicts 2D6+4 M.D. when they are used to spread openings and otherwise pry open doors/hatches or tearing through debris and hulls (not applicable to punches). Despite the strength of the Jaws of Life, the pilot can control them to lift and move the injured very gently.

Payload: Effectively unlimited.

b) M.D. Chainsaw (1 per hand): Same as the MMB-01 Big Papa Mobile Medical Robot, just smaller. Each hand has a two foot (0.6 m) long chainsaw blade for cutting through M.D.C. doors, hulls, walls, and collapsed structures to free people who are trapped and injured. When not needed, the tool folds back and slide behind the hand to stow inside a forearm housing. It takes two melee actions to extend the chainsaw or to put it in its stowed position.

Primary Purpose: Rescue and Cutting through wreckage/debris.

Secondary Purpose: Anti-Fortification, Sabotage and Defense.

Range: Touch/close combat.

Mega-Damage: The chainsaw does 2D6+3 M.D. per attack, and even when turned off, it does 1D4 M.D. as a blade weapon plus Robot P.S. punch damage for slashing attacks.

Payload: Effectively unlimited.

c) Laser Torch (1 per hand): Same as the MMB-01 Big Papa Mobile Medical Robot, just smaller and less damage. The utility hand has a finger that is a precision cutting device for slicing through debris to free the trapped and injured. It can fold up when not in use. Point and fire.

Primary Purpose: Cutting and Rescue.

Secondary Purpose: Defense.

Range: 40 feet (12.2 m).

Mega-Damage: All of the following settings are available: 1D6 S.D.C., 2D6 S.D.C., 4D6 S.D.C., 1D4x10 S.D.C., 1 M.D. and 1D4 M.D.

Rate of Fire: Each blast counts as one melee attack/action.

Payload: Effectively unlimited.

d) Laser Scalpel (1 per hand): Similar to the laser of the MMB-01 Big Papa Mobile Medical Robot, but a little less range of damage. Used for delicate cutting, repairs and actual field surgery. Ideal for soldering, cutting away objects and wire, removing limbs and cauterizing wounds. Point and fire. Folds back when not in use.

Primary Purpose: Cutting and Rescue.

Secondary Purpose: Defense.

Range: 12 feet (3.6 m).

Mega-Damage: All of the following settings are available: 1 S.D.C., 1D4 S.D.C., 2D4 S.D.C. and 3D4 S.D.C.

Rate of Fire: Each blast counts as one melee attack/action.

Payload: Effectively unlimited.

e) Clamp Finger (1 per hand): Same as the MMB-01 Big Papa Mobile Medical Robot, just smaller and not quite as powerful. This two-finger apparatus is used to clamp and tear away (Robotic P.S. 30), grip and hold or grip and lift objects or the patient. When not needed, it folds up and tucks back behind the palm.

f) S.D.C. Cutting Tool (1 per hand): Same as the MMB-01 Big Papa Mobile Medical Robot, just smaller and not quite as powerful. This is a comparatively small, circular blade the size of a coffee cup saucer. It is a precision cutter use to remove clothing and cut through light S.D.C. material.

Primary Purpose: Rescue and Cutting.

Range: Melee combat.

Mega-Damage: Not applicable; does 1 S.D.C., 1D4 S.D.C. or 1D6 S.D.C.

Payload: Effectively unlimited.

Note: Each finger has an infrared and conventional light beam (200 foot/61 m range) and digital video camera that feeds directly into the crew compartment. Live feed can be relayed to the medical crew as well. This enables the team to find victims trapped in debris, assess damage and conditions, and see into narrow places.

3. Hand to Hand Combat: Rather than use a weapon, the pilot can engage in Mega-Damage hand to hand combat as per *Robot P.S. 30*. However, the Mobile Medical Robot is NOT designed for fighting. See *Heavy Ground Robot Training* on page 352 of **Rifts® Ultimate Edition**, and reduce the bonuses by half, round down.

4. Sensor Systems and Other Features of Notes: In addition to those common to all robot vehicles, the MMB-02 has all the same sensors and attributes as the MMB-01 Big Papa Mobile Medical Robot, just smaller.

A. Sensor Arm with Thermal Imager and Display Screen

(1, right): The arm can extend 15 feet (4.6 m) and rotate 360 degrees at the shoulder mounting and at the monitor mounting at the end of the arm. The arm is thin and flexible with 20 M.D.C., the acoustic array has 8 M.D.C., the thermal imaging sensor wand has 6 M.D.C. and the monitor has 3 M.D.C. All require a Called Shot to be hit by an enemy, and the shooter does so with a penalty of -5 to strike.

B. Multi-Purpose Searchlight Arm (1, left): The arm is thin and flexible (20 M.D.C.; and the sensor box where the light and camera are located has 20 M.D.C.). The light beam has a maximum range of 2,000 feet (610 m). The long-range,

directional radio has a range of 500 miles (800 km) and relay capabilities. Arm can extend 15 feet (4.6 m).

C. Thermal Imager: Perfect for seeing through smoke and can help to find victims caught in a fire or on a smoky battlefield. Range: 1,200 feet (366 m).

D. Finger Multi-Medical Scan System and Camera: NOT available to the MMB-02 Junior.

E. Field Hospital Clinic: Same as the MMB-01 Big Papa Mobile Medical Robot, just smaller. The MMB-02 functions as a mobile field hospital with a full medical team inside the robot. When it is necessary to expand the capabilities of the medical facility, the robot goes into vehicle mode and tarps can be removed from compartments on the sides of the MMB-01 to create additional, tent-like awnings with drop down mosquito netting for the sides of the enclosure. This provides a temporary shelter for additional wounded that is 10 feet (3 m) by 10 feet (3 m) in size. All such items are usually part of the MMB-02's standard cargo.

F. Automated med-beds (8): Each holds the patient securely, administers proper medication, blood/plasma, nutrients and oxygen (as needed), keeps the patient stabilized, and monitors vital statistics (heart rate, respiration, blood pressure, etc.).

G. Nano-Robot Medical Systems: Same as the MMB-01 Big Papa Mobile Medical Robot, just fewer. 24 of each minimum. Many have two or three times that number. Twenty-four of each comes standard with the MMB-02 Junior.

NG-M56

'Original' Multibot

The M56 Multibot is another one of Northern Gun's older robot models. At the time of its release in 100 P.A, it was the company's most ambitious and most *unusual* robot vehicle design. Intended to be an all-purpose robot with both light combat and exploration applications, the robot vehicle has a number of diverse features. The main weapons are a heavy ion cannon mounted in its mid-section that swings up and forward when needed, and a new-style missile launcher built into the back. When the missiles are to be launched, two scissor-shaped arms swing up and lock into a V shape. When not needed, the two appendages swing back down, folded behind the robot (the illustration shows the launchers locked in firing position). The shoulder shields flip out to fire mini-missiles and a gunner's hatch is located on the top of the robot, with an NG-101 rail gun mount.

The most unique feature is that the head-like upper body is a hover vehicle that can separate from the shoulders and waist to fly away. The flying head can detach and reattach with ease, although docking back with its main body is the more difficult procedure and requires 1D4 minutes to fit into place. Disengaging from the humanoid shaped part of the robot is instant, but the V-missile launchers must be in the down position and all missile defenses are left behind. Once detached, the only weapon systems are the ion cannon, which sticks straight out forward, and the hatch rail gun. The arms, legs, missiles and humanoid armature are all left behind and are vulnerable to attack unless a sentry or another robot is left behind to guard it. The idea was to create a dual system transport that was part hover car and part robot. The flying section could detach to scout ahead or navigate trails too

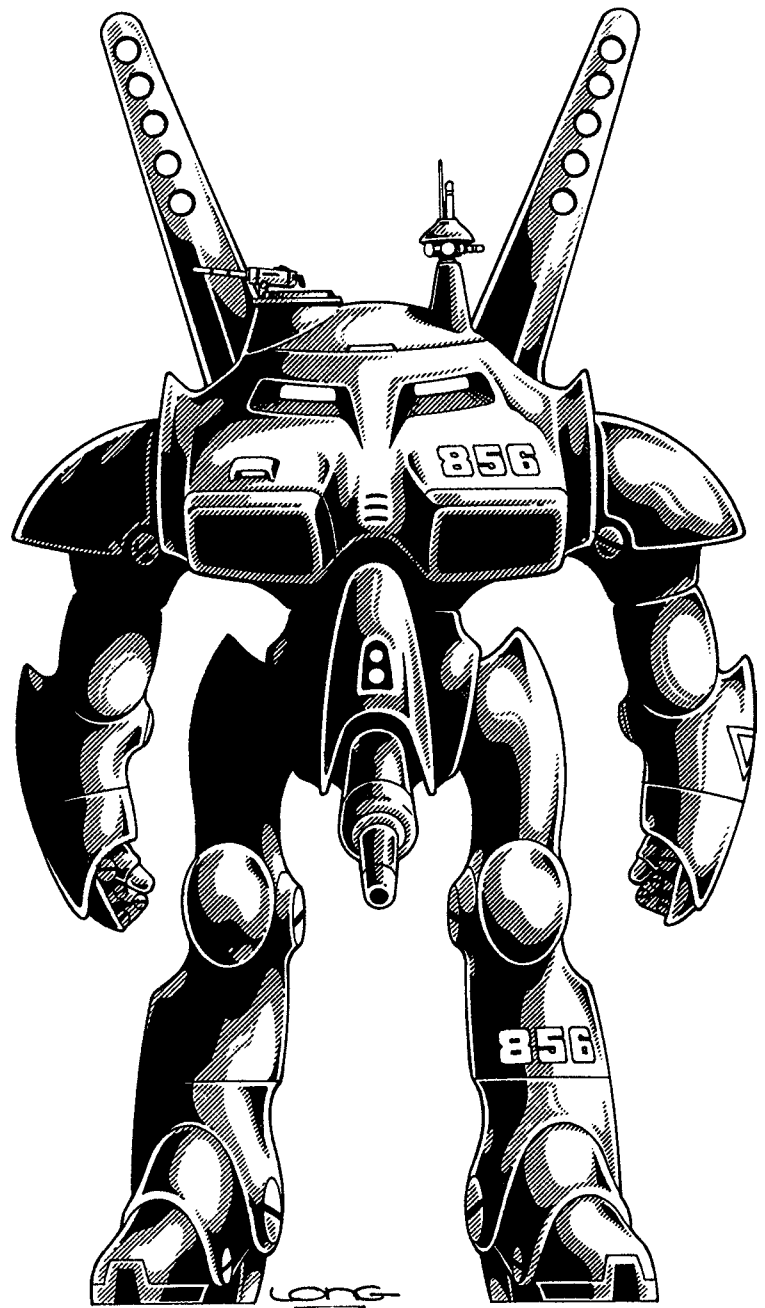

narrow for the giant robot, drive into communities where robots are not allowed, or abandon the robot to make good an escape.

Some genius at Northern Gun thought this was the robot vehicle of the future and rushed it into mass production. However, the Multibot never won customer acceptance. Its light armor and funky appearance had a great deal to do with that. As one designer noted, "The old M56 Multibot lacked sex appeal." In 107 P.A. the line was discontinued.

NG-M56 Multibot

Model Type: NG-M56

Class: Modular Ground Assault Robot Vehicle.

Crew: Two; pilot and copilot, and can accommodate six passengers.

M.D.C. by Location:

V-Missile Launcher Arms (2) – 120 each

Shoulder Mini-Missile Shields (2) – 100 each

Ion Cannon (1, mid-section) – 100

* Hands (2) – 25 each

Forearms (2) – 90 each

Upper Arms (2) – 100 each
 Legs (2) – 200 each
 * Spotlight (1, above right exhaust vent) – 10
 * Headlights (2, undercarriage) – 5 each
 * Sensor Turret (1; left shoulder) – 50
 * Reinforced View Ports (2, eye-like windows) – 12 each
 Reinforced Pilot Compartment (inside hover craft) – 100
 Detachable, Flying Hover Craft (1; upper body) – 200
 ** Main Body (the supporting armature) – 290

* A single asterisk indicates a small and difficult target to strike, requiring the attacker to make a *Called Shot*, but even then the attacker is -4 to strike.

Destroying the sensor turret of the robot eliminates all forms of optical enhancement and sensory systems. The pilot must rely on his own human vision and senses; no bonuses to strike, parry, and dodge. **Note:** The sensor turret is a small target and is difficult to hit; requires a *Called Shot* and even then the attacker is -4 to strike.

** Depleting the M.D.C. of the main body shuts the robot section down completely, making it useless. However, the upper, hovercraft section can detach and fly away. **Note:** When assigning main body damage, after 100 M.D.C. is lost, it is best to *divide the damage* between the *main body* and the upper *hover craft* portions of the body (both large targets). When the hover craft's M.D.C. is depleted, it can no longer fly. But it may continue to function as the robot's command center until the reinforced pilot compartment is reduced to zero M.D.C., at which point the robot shuts down.

Speed:

Running: 60 mph (96 km) maximum. Note that the act of running does NOT tire out its operator. Cruising speed is a more cautious 35 mph (56 km). Well suited for most terrains, including underwater, but does not handle climbing or mountainous terrain well.

Leaping: 10 feet (3 m) high or across from a stationary position; 20 feet (6 m) high or 30 feet across (9 m) with a running start.

Water: Fair; able to walk along the floor of lakes and seas at half the robot's normal speed. The hover craft can ride atop the surface of water at speeds up to 120 mph (192 km or 104 knots). Maximum depth tolerance, however, is only 1,500 feet (457.2 m).

Flying (Hovercraft Only): The pilot and crew compartment is built into the upper section, which is also an independent hover vehicle that can separate from the main body of the robot and fly. The flying helm can attach and reattach as often as necessary, but the main body remains immobilized until the hover craft returns.

Flying speed of the hovercraft is 240 mph (384 km) and can reach an altitude of 10,000 feet (3,048 m); +4 to dodge when flying. It can also hover stationary or hug the surface, hovering about 5 feet (1.5 m) above the ground. VTOL capable.

Statistical Data:

Height: 26 feet (7.9 m) from head to toe with missile arms down. 34 feet (10.4 m) with the missile launchers extended.

Width: 20 feet (6.1 m).

Length: 19 feet (5.8 m).

Weight: 30 tons fully loaded, 24 tons without missiles, 20 tons without missile arms.

Physical Strength: Equal to a Robotic P.S. 40.

Cargo: Small area for the pilot's personal items, as well as a weapon bin that has room for four rifles, pistols, four suits of body armor, canteens and food rations (4 week supply). A small

refrigeration unit and a 100 gallon (378.5 liter) water cooler are built into the cockpit.

Power System: Nuclear, 18 year life.

Cost: List price was 34 million, but for 18-22 million credits, a new, undamaged, full combat unit complete with missiles can still be found. Used Multibots sell for as little as 10 million credits. Good availability in Upper Michigan, Kingsdale, MercTown, Arzno and other places that cater to soldiers and adventurers.

Weapon Systems:

1. Scissor Launchers (2): Ten medium-range missiles are mounted in two V-shaped launchers (five each) on the robot's back.

Primary Purpose: Assault and Anti-Fortification.

Secondary Purpose: Defense and Anti-Armor/Monsters.

Range: Usually around 40 miles (64 km).

Mega-Damage: Varies with missile type. Any medium-range missile can be used, but standard issue is armor piercing (2D4x10 M.D.) or high explosive (2D6x10 M.D.).

Rate of Fire: One at a time or in volleys of 2, 3 or 4.

Bonus: +1 to strike; guided missiles.

Payload: 10 missiles; five in each launcher.

2. Concealed Shoulder Mini-Missile Launchers (2): Behind each shoulder shield is a mini-missile launcher.

Primary Purpose: Anti-Aircraft and Defense.

Secondary Purpose: Anti-Armor and Anti-Missiles.

Range: One mile (1.6 km).

Mega-Damage: Varies with missile type. Usually fragmentation (5D6 M.D.) or plasma (1D6x10 M.D.).

Rate of Fire: One at a time or in volleys of 2 or 3.

Payload: 18 total; nine in each shoulder.

3. Heavy Ion Cannon: The single-barreled ion blaster is designed to counter ground troops. Fixed forward, with a 90 degree angle up and down.

Primary Purpose: Assault.

Secondary Purpose: Defense.

Range: 4,000 feet (1,219 m).

Mega-Damage: 5D6 M.D. per single blast.

Rate of Fire: Each blast counts as one melee attack.

Payload: Effectively unlimited.

4. NG-101 Light Rail Gun (1): The light rail gun is built into a swivel mounting on top of the flying helm portion of the Multibot. The gun can rotate 360 degrees and can point 90 degrees up and down. A gunner must man the gun.

Primary Purpose: Assault.

Secondary Purpose: Defense.

Range: 4,000 feet (1,219 m).

Mega-Damage: 6D6 M.D. per 30 round burst.

Rate of Fire: Each blast counts as one melee attack.

Payload: 1,800 rounds (60 bursts).

5. Hand to Hand Combat: Rather than use a weapon, the pilot can engage in Mega-Damage hand to hand combat, inflicting damage as per Robot P.S. of 40. See *Heavy Ground Robot Training* on page 352 of **Rifts® Ultimate Edition** for the number of attacks and bonuses. **Note:** The Multibot can *NOT* perform a Restrained Punch, Power Punch, or a Leap Kick.

6. Sensor System Notes: Basic robot systems with advanced radar. Can identify and simultaneously track up to 96 different targets. **Range:** 100 miles (160 km).

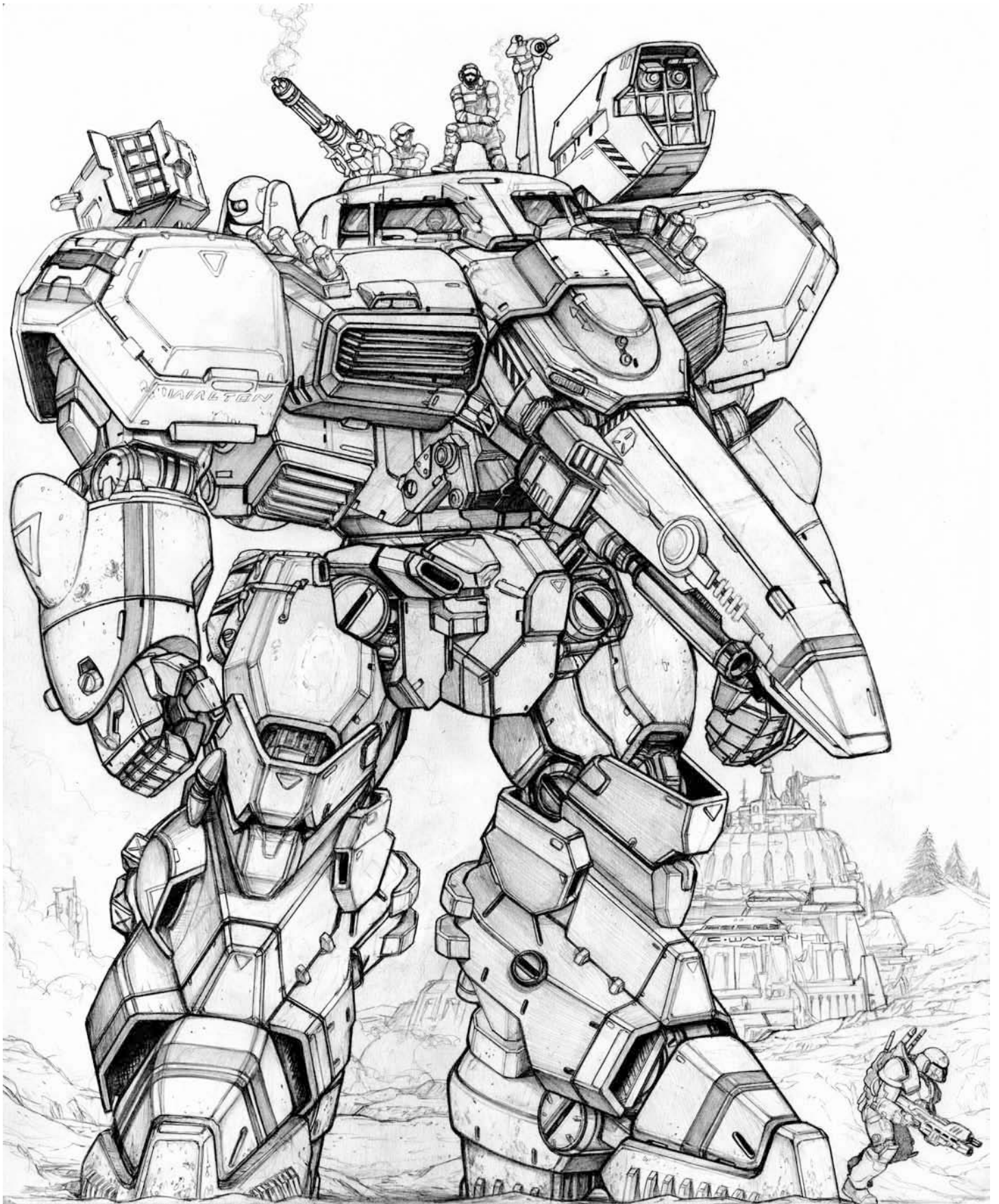

NG-M57-2N1 Megabot

Always the odd man out in Northern Gun's product line, the complex and unique Multibot never caught on with customers as expected. It has always had its fans, however, especially amongst Ishpeming's engineers and Operators. Their love for the sophisticated machine (as well as political pressure for new jobs) has led to the reopening of the Multibot assembly line and the creation of an updated variant re-designated as the Megabot. The revamped Megabot was unveiled along with Northern Gun's new catalog and marketed as a battlefield command robot in the Spring of 109 P.A., sold as the ultimate VIP escort platform and exploration vehicle. A two-in-one vehicle capable of carrying up to six passengers safely within a combat robot chassis, yet able to fly away at a moment's notice in the detachable hover-racer that is the upper body section.

Unlike the Multibot, the Megabot has the look of military hardware, heavy armor, and power. When tromping through uncharted wilderness or across the battlefield, the giant combat robot has decent speed and a battery of weapons that includes mini-missiles, short-range missiles, medium-range missiles and a triple-barreled laser. This gives it plenty of punch. The Megabot is also well armored and one of the largest robots to roll off the Northern Gun assembly lines.

When there is the need for speed, a reconnaissance patrol, rapid response, or a lightning quick assault or getaway, the upper body of the Megabot detaches, with its entire crew and passengers, and rockets across the landscape as a hover combat racer. A racer with a heavy ion cannon built into the undercarriage of its forward section.

The release of the Megabot has received rave reviews and has been well received by the public. Critics, however, insist the robot has the same problems as the Multibot. **One**, while the hover racer is stylish and inviting, it gets in the robot's way during hand to hand combat, provides a tempting target, and gives giant enemies something to grab onto in close combat. It also creates a blind spot under its belly.

Two, the forward section of the combat racer (Main Body) makes the robot a bit top heavy and off balance (+10% to knock it off its feet with a body block or ram attack).

Three, when the combat racer breaks away, it leaves the body chassis, arms, legs and missile launchers behind, immobile and completely unprotected.

Four, if the combat racer is destroyed when detached, the rest of its body housing is inoperable and immobilized. An easy target for theft, salvage or enemy attack.

And new to the Megabot, the big ion cannon built into the racer can only fire in a downward 45 degree angle at the ground while it is part of the larger robot. It cannot fire forward until the combat hover racer detaches from the rest of its body armature. Even then, the big gun can only fire forward, though the tri-barrel laser cannon on the top of the armored vehicle can rotate 360 degrees and has a sweeping 90 degree up and down arc of fire.

Despite these alleged 'flaws,' the Megabot is impressive. Its initial sales are outpacing the Multibot three to one, and expected to improve as word about the robot spreads. Why? Because it is a remarkable, versatile and daring NG creation, especially appealing to speed-junkies, robot aces and special forces. Soldiers are quick to point out that most large combat vehicles and giant

robots have weak spots/vulnerabilities. The Megabot is no different. To take full advantage of its versatile, quick-strike capabilities, it should be escorted by one or more smaller robots, combat vehicles, power armor units or troops to defend its legs and robotic body when the combat racer detaches to engage in other vital missions.

As an exploration robot, The Megabot can find a safe location to 'park' and let the combat racer detach to engage in reconnaissance, make supply runs, investigate areas quickly, get out of trouble quickly, and to arrive at exploration sites, towns and other locations as fast as a hovercycle, only it carries along the entire team of six in the process. When a standing fight is necessary, the two-in-one robot can pound an attacker or enemy with a hail of missiles and then break away to charge forward and attack with the combat racer, outflank a slower adversary before they realize what's happening or make a hasty retreat.

In a combat role, as a one piece combat robot, the Megabot can provide troop support by hammering the enemy or breaking through fortifications with its array of missiles. This can also be done to cover a retreat. Then, if the situation allows it, the combat racer can detach to engage the enemy or further assist ground troops. The fast moving, high-powered and well armored racer is effective at search and rescue operations, border patrols, making supply runs, delivering messages, fast insertions and extractions in hot zones, medevac for wounded troops, engaging in fast response to enemy attacks with heavy firepower of its own and chasing down and destroying hovercycles, ground vehicles and low flying power armor.

NG-M57-2N1 Megabot

Model Type: NG-M57-2N1 Megabot.

Class: Modular Multi-Piece Ground Assault Robot Vehicle.

Crew: Two; pilot and gunner, both of whom sit in a forward cockpit in front of the passenger section. This forward cockpit has a sliding shield covering that completely covers the cockpit (120 M.D.C.), requiring the crew to pilot via instruments or video.

Passenger or Additional Crew: Accommodates six additional people seated (9 under cramped conditions, kneeling or sitting on the floor between seats). These may be additional crew members such as a laser cannon gunner, communications specialist and additional troops, or adventurers or short-term passengers.

M.D.C. by Location:

- * Short-Range Missile Launcher (1, right shoulder) – 100
- * Medium-Range Missile Launcher (1, left shoulder) – 150
- * Sensor & Communications Array (1, left shoulder) – 50
- Shoulders/Upper Arms (2; heavy armor) – 270 each
- Forearms (2) – 200 each
- Hands (2) – 100 each
- Legs (2) – 275 each
- * Supporting Armature/Docking Port (upper body when racer is gone) – 160

M.D.C. of Combat Racer Section:

- * Racer Sensor Sphere (1) – 35
- * Tri-Laser Cannon (1, top; combat racer) – 100
- ** Ion Cannon (1, combat racer) – 200
- ** Mini-Missile Launch Tubes (8, combat racer) – 25 each
- * Headlights (6 total in racer) – 5 each

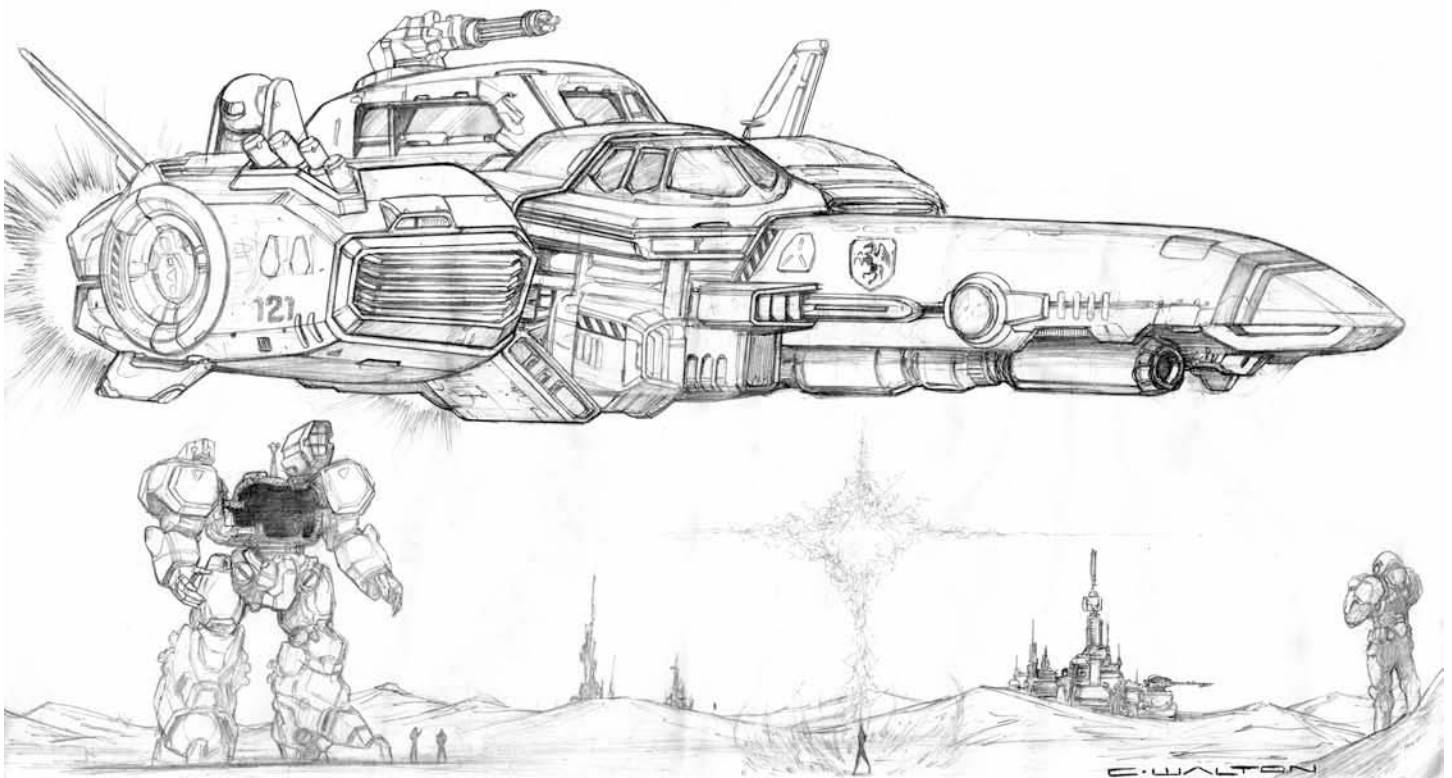

- * Passenger Compartment Windows (4; heavy M.D.C. plexiglass) – 20 each
- ** Passenger Compartment Window Plates (4; with cameras) – 50 each
- * Cockpit Windows (6; heavy M.D.C. plexiglass) – 20 each
- ** Cockpit Pop-Off Cover (1, with cameras) – 120
- ** Airfoil Fins (2, combat racer) – 30 each
- * Main Rocket Thrusters (2, large) – 150 each
- * Secondary Thrusters (2, small, low) – 50 each
- * Hover Thrusters (5, undercarriage) – 20 each
- * Small Maneuvering Jets (4, concealed) – 12 each
- Reinforced Crew Compartment (inside racer) – 100
- *** Main Body/Combat Racer (upper body) – 375

* A single asterisk indicates a small and difficult target to strike, requiring the attacker to make a “Called Shot,” but even then the attacker is -3 to strike (-5 when the combat racer is moving faster than 60 mph/96 km).

Destroying both the sensor sphere and the sensor/communications array eliminates all forms of optical enhancement and sensory systems. (Destroying one does nothing to impair the robot.) Without sensors, the pilot must rely on his own human vision and senses; no bonuses to strike, parry, and dodge.

** Two asterisks indicate a very small, difficult target to hit, requiring a “Called Shot” to hit with a -4 penalty to strike (-6 when the combat racer is moving faster than 60 mph/96 km).

M.D.C. plexiglass windows in the passenger compartment have 20 M.D.C. each, but a metal alloy plate covering slides into place in combat situations with the press of a button or voice command. The metal plating provides each window

with an additional 50 M.D.C. The pilot’s cockpit also has plexiglass windows, but they do not come into play unless the cameras and sensors are knocked out, or the one piece metal covering (120 M.D.C.) is reduced to zero M.D.C., at which point the cover piece is ejected. The pilot drives via instruments and video images from a number of cameras. Two cameras are built into the pop-off shield cover, another is located in the tall sensor/communication array over the left shoulder and there is a concealed camera in the nose and rear of the vehicle. When the windows are visible, an attacker needs to make a *Called Shot* to target a specific window with the penalty noted above. Destroying the M.D.C. of the window plexiglass and M.D.C. shielding makes the Reinforced Pilot Compartment vulnerable to attack in the cockpit. Passengers can be targeted via a Called Shot (-4 to strike) when both the metal plate and window are destroyed.

Destroying one fin makes the combat racer a bit less stable: -2% to speed and inflicts a piloting penalty of -2%; -5% to speed and penalty when both fins are destroyed.

Destroying one of the main turbojets reduces speed and dodge bonuses by half and inflicts a -20% piloting penalty. Destroying both of the big jets eliminates the dodge bonus and reduces speed to a crawl: 30 mph (48 km) and max altitude is 30 feet (9.1 m)! The -20% piloting penalty remains in place but it increases to -40% when trying to perform evasive or trick maneuvers.

*** The *combat racer* counts as the **Megabot’s main body**. Reducing its M.D.C. to zero or below shuts it (and the rest of the robot) down completely, making it useless. Destroying the combat racer when it is detached and away leaves the rest of

its body immobile, stranded and vulnerable to theft, vandalism and attack without defense (unless someone is standing guard).

Speed:

Running: 55 mph (88 km) maximum. Cruising speed is a more cautious 35 mph (56 km). Well suited for most terrains, including underwater.

Leaping: Clumsy, 10 feet (3 m) high or across from a stationary position; 20 feet (6.1 m) high and across with a running start.

Water: When the racer is attached to the rest of the robot, the Megabot can walk along the floor of lakes and seas at a speed of 20 mph (32 km). Maximum Depth: 2,000 feet (610 m). **Note:** The combat racer can NOT travel underwater, but can hover on the surface of water as deep as 60 feet (18.3 m). Sinks in deeper waters! Speed on water surface is a maximum of 120 mph (192 km or 104 knots).

Flying (Combat Racer Only): The combat racer cannot actually fly like an aircraft, but can rocket along the ground like a rocket bike. Speed: 250 mph (400 km). Maximum Altitude: 500 feet (152 m). It can also hover stationary or hug the surface, riding as low as 4 feet (1.2 m) above the ground. VTOL capable and can rotate 360 degrees when in a stationary hover mode. **Note:** The pilot and passenger compartments are built into the upper section (racer), the independent hover vehicle that can separate from the rest of the robot body. This section contains the two energy weapons and mini-missiles, as well as the power supply. It detaches and reattaches as often as necessary, but the rest of its robotic body remains immobilized until the combat racer returns. If the racer is destroyed when away, its other half remains immobilized until a replacement racer can be acquired or the rest of the robot is hauled away by other means.

Statistical Data Megabot:

Height: 37 feet (11.3 m).

Width: 24 feet (7.3 m).

Length: 27 feet (8.2 m) with the combat racer locked in a diagonal position pointing at a down slope.

Weight: 51 tons fully loaded.

Physical Strength: Robot P.S. 40.

Power System: Nuclear, 15 year life. Solid Oxide Fuel Cell system is an available alternative.

Cost: The Megabot with combat racer, a nuclear power supply and full missile payload costs 42 million credits, 36 million for a Solid Oxide Fuel Cell power system. Cannot use electric batteries. The hovercraft contains the power supply and the rest of the body has no energy when the hovercraft is detached from it.

Statistical Data Combat Racer:

Height: 16 feet (4.9 m) from belly to top of the laser cannon. Concealed land gear, on wheels adds 3.6 feet (1.1 m) when parked.

Width: 12 feet (3.6 m).

Length: 30 feet (9.1 m).

Weight: 16.3 tons.

Physical Strength: Not applicable.

Cargo (Combat Racer): In addition to seating for six in the passenger compartment, there is a weapons locker the size of a small closet, a tiny toilet and washroom (similar to what you find on a commercial aircraft), a place under the seats to stow a backpack and an overhead bin like those in commercial aircraft. There is space for more baggage and gear in the aisle, but using it for packages/gear will block the passengers' path and may require

them to step or crawl over the packages. A small refrigeration unit and a 120 gallon (454 liter) water cooler are built into the passenger area.

In the cockpit, there is an area for the pilot's personal items, as well as a weapon bin that has room for four rifles, pistols, two Vibro-Knives (1D4 M.D.), two suits of body armor, four canteens and food rations with a one week supply for two people.

Power System: Nuclear, 20 year life for just the racer when it is not part of the bigger robot body. Solid Oxide Fuel Cell is an available alternative. Electric batteries cannot be used. The combat racer contains the power supply for the robot.

Cost of Combat Racer: The combat racer can be purchased separately as a stand-alone vehicle for 14 million credits with a nuclear power supply and 9 million with a Solid Oxide Fuel Cell.

Note: The nose of the Megabot racer is jointed to bend at an angle when docked with its robotic body, but the vehicle model is usually braced to be one, rigid piece. The braces can be removed to work with a Megabot body.

Weapon Systems:

1. Medium-Range Missile Launcher (1): A medium-range missile launcher is mounted on the left shoulder.

Primary Purpose: Anti-Armor.

Secondary Purpose : Anti-Aircraft.

Range: Usually about 40+ miles (64+ km).

Mega-Damage: Varies with missile type. Any medium-range missile can be used, but standard issue is armor piercing (3D6x10 M.D.) or high explosive (2D6x10 M.D.).

Rate of Fire: One at a time or in volleys of 2, 3 or 4.

Bonus: +1 to strike.

Payload: Nine medium-range missiles.

2. Short-Range Box Missile Launcher (1): A short-range missile launcher is mounted on the right shoulder.

Primary Purpose: Anti-Armor.

Secondary Purpose : Anti-Aircraft.

Range: Usually about 5 miles (8 km).

Mega-Damage: Varies with missile type. Any short-range missile can be used, but standard issue is armor piercing (2D6x10 M.D.) or high explosive (2D6x10).

Rate of Fire: One at a time or in volleys of 2, 4 or 8.

Bonus: +1 to strike.

Payload: 16 short-range missiles.

3. Mini-Missile Tube Launchers (8): Mounted on the side of each jet thruster of the combat racer are four mini-missile launchers. Each launch tube can be turned 120 degrees in an arc of fire behind, above and forward.

Primary Purpose: Anti-Aircraft and Defense.

Secondary Purpose: Anti-Armor and Anti-Missiles.

Range: One mile (1.6 km).

Mega-Damage: Varies with missile type. Usually fragmentation (5D6 M.D.), armor piercing (1D4x10 M.D.) or plasma (1D6x10 M.D.).

Rate of Fire: One at a time or in volleys of 2, 3, 4 or 8.

Payload: 24 total; three per launch tube. Automatic reload after a missile is fired.

4. NG-IRC57 Heavy Ion Cannon (1): A single-barreled ion blaster is built into the undercarriage of the combat racer. When the racer is connected to the large robot, the big gun points down at a 45 degree angle in a fixed-forward position. This renders it nearly ineffective, because it can only be used

against ground troops very close to the Megabot. To fire in a different direction, the robot must turn its entire upper torso, which can rotate at the waist 180 degrees.

When detached from the rest of the Megabot, the cannon becomes the formidable main gun of the combat racer. It is fixed forward and fires in the direction the racer is pointed. Used to blast targets at a distance and strafe hovercycles, ground vehicles and troops, as well as engage rocket bikes and power armor in low altitude dogfights.

Primary Purpose: Anti-Hovercycles and Assault.

Secondary Purpose: Anti-Personnel and Defense.

Range: 4,000 feet (1,219 m).

Mega-Damage: 1D4x10 M.D. per single blast.

Rate of Fire: Each blast counts as one melee attack.

Payload: Effectively unlimited.

5. NG-LC57 Tri-Barrel Heavy Laser Cannon (1): This triple-barreled laser cannon is mounted on a turret that can be manned by a gunner or operated remotely from inside the combat racer; usually by a dedicated gunner or the copilot. It can rotate 360 degrees and has a 90 degree up and down arc of fire. It is part of the combat racer.

Primary Purpose: Anti-Personnel and Assault.

Secondary Purpose: Anti-Flyers and Defense.

Range: 2,000 feet (610 m).

Mega-Damage: 3D6 M.D. per single blast, 6D6 M.D. per double blast and 1D6x10 M.D. per triple blast.

Rate of Fire: Each single blast or simultaneous dual or triple blast at the same target counts as one melee attack/action.

Payload: Effectively unlimited.

6. Hand to Hand Combat: Rather than use a weapon, the pilot can engage in M.D. hand to hand combat. See *Heavy Ground Robot Training* on page 352 of **Rifts® Ultimate Edition** for the number of attacks and bonuses, except the Megabot cannot perform a Power Punch nor a Leap Kick.

7. Robot Sensors and Features: All standard robot features, plus multiple cameras for driving, flying and navigation.

Tactical Cameras: The digital video cameras send live feeds directly into the cockpit and HUDs of helmets of passengers. Live feed can be relayed throughout the robot and displayed on monitors, HUDs and a screens not only to those inside the Super Max but to robots in the same company, mobile command, and any designated recipient within range (500 mile/800 km transmission range). Each camera has a 4,000 foot (1,219 m) range with telescopic lenses as well as macro-lenses for seeing up-close, x10 magnification. Can store up to 10,000 hours of video footage before requiring transfer to some other medium. Includes image and video transmission capabilities.

NG-EXC-17 Ogre

Exploration & Labor Robot

The Ogre comes from the drawing board of lead designers **Ammon Redman, Ramzie Othman and Frederick R. Seibel the 5th**. It gets its name from its brutish and stocky build, massive hands, squat, hunched shape and brutal power. Even at rest, the robot looks as if it is ready to lunge forward or wrestle. The Ogre is a heavy, multi-purpose robot designed to perform double-duty as a heavy labor robot and wilderness explorer/camper. As such, speed and weaponry have been sacrificed for strength, armor, multi-purpose hands and sleeping/living quarters inside the robot. There are camper/sleeper compartments for four people (as many as 8-12 under cramped conditions with people sleeping on the floor and in the cockpit). There is also a storage bay the size of a walk-in closet, a mini-shower and toilet, and an ample supply of water.

Each oversized hand has diverse functionality. The right hand has better articulation than the left, and is suitable for picking up and examining specimens as well as handling heavy cargo, hauling lumber, ripping out trees by their roots, or crushing stone. A camera and sensor pod is mounted on the hand to memorialize operations, video wildlife and to scan potential ore deposits, construction sites, wreckage and whatever else needs to be examined or documented. The camera sensor pod can retract into a special housing during heavy work, as well as move on a track to other locations on the hand and wrist to position itself out of harm's way during work and combat.

The left hand is designed for lifting fallen trees and debris, lumber operations (uprooting small to medium-sized trees, cutting down large trees, hauling trees, etc.), digging, mining, drilling and excavation, as well as heavy construction work and recovering robots and scrap. In fact, the Ogre can lift 5x more than is usual for its Robot Strength class (P.S. 45), and is capable of pulling 12x more. One feature not immediately apparent is that the fingers of the left hand can lock and the entire hand can rotate at the wrist to cut down trees, drill into solid earth and rock, or bore through M.D.C. fortifications. This function is ideal for digging trenches and foundations, starting the entrance to mines, digging up gravel pits, pulverizing stone and demolitions and tearing down walls or buildings. Actually, the Ogre is suitable for all sorts of construction work and cargo hauling operations, as well as robot field repair, robot retrieval, salvage operations, gathering large pieces of scrap, cutting down robots and armored vehicles for scrap and recovering robots and armored vehicles that have stopped working or gotten themselves stuck.

The pilot compartment in the nose of the Ogre, with its seven windows and seating for five, provides an excellent view for explorers, travelers and workmen. Passengers are a bit of a liability in combat, however, but the Ogre is not intended for battle. Weapon systems are simple and limited. There is a medium ion turret in the nose and a pop-up mini-missile launcher on the top near the left shoulder. The entire upper torso of the Ogre can rotate 360 degrees to face any direction; a nice feature for exploration, construction and combat. And when it is forced into combat, the Ogre is big and heavy enough to wrestle with dinosaurs, giant monsters and robots of equivalent size and up to 20% larger. Its wedge shape, short legs and large feet make the stout robot almost impossible to knock down, even with a high-speed

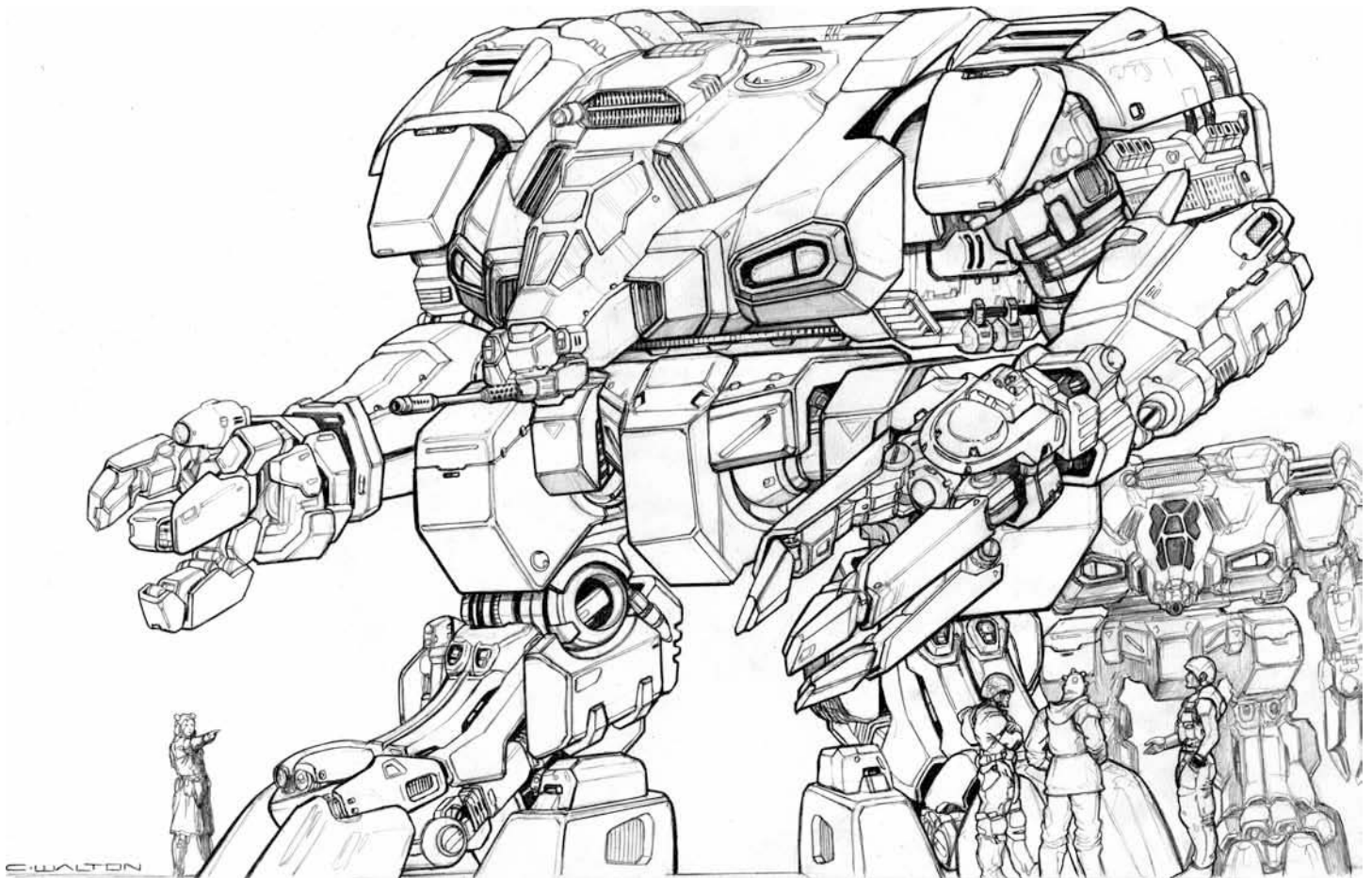

ramming attack, and its oversized hands and great strength are devastating in hand to hand combat. All of this makes the Ogre a sturdy workhorse and exploration robot of considerable strength and versatility.

If there is a downside to the Ogre, besides its vulnerable windows, it is its ponderous maximum speed of 35 mph (56 km). It was reasoned that the dual function of a heavy work robot and exploration vehicle didn't require speed or weapons. Most explorers want to travel slowly to avoid missing something extraordinary or to take photos and make notes as they travel. Tools and capabilities like cutting, drilling and digging give explorers and adventurers the capability to engage in mining, lumber and salvage operations, as well as the excavation of ancient ruins. And the Ogre can handle most difficult terrains and dangerous environments. It can wade across rushing rivers, plod through lakes, hold its ground against mud slides and flash floods, has little to fear from herds of large animals or giant predators, and handles snow and arctic conditions better than most other robots.

When it comes to harsh winters, the likes of which are common to Northern Michigan, Canada and other parts of North America, you want a big robot like the Ogre, unaffected by the deepest snowfalls. In fact, the Ogre is often sent out to rescue other robots and vehicles stuck in snow or lost in a blizzard. The Ogre slogs through deep snow, handles ice without falling and plows through the tallest snowdrifts with little difficulty; its speed and mobility virtually unimpaired. In situations like these, slow and steady wins the race, and the hotshot crews of those fast robots bristling with weapons are thrilled to see the Ogre come to pull them out and escort them home.

Ogre Multipurpose Explorer and Labor Robot

Model Type: NG-EXC-17 Ogre.

Class: Exploration and Construction Robot Vehicle.

Crew: Two: One pilot and one copilot/communications engineer or Operator. Has seating for three passengers in the cockpit, but only has four living compartments. **Note:** The controls are designed so that the pilot can handle all functions and weapons if necessary.

M.D.C. by Location:

- * Upper Arms (2) – 200 each
- Right Forearm (1) – 200
- Right Hand (1) – 150
- Left Forearm (1) – 270
- Left Hand (1) – 250
- Camera & Secondary Sensor Pod (1; Right Hand) – 35
- Legs & Feet (2) – 330 each
- * Nose Turret (1) – 90
- * Nose Sensor Array (1; on side of turret) – 25
- * Chest Headlights (2; large) – 20 each
- * Toe Headlights (4; two per foot) – 12 each
- ** Plexi-Windows (7) – 15 each
- ** Window Plate Shielding (7) – 50 each
- Main Hatch (1, top behind cockpit) – 110
- Emergency Hatch (2; one top, one rear) – 75 each
- Nose/Head/Cockpit Area (1; midsection) – 200
- Reinforced Pilot Compartment – 100
- *** Main Body – 570

* A single asterisk indicates a small and difficult target to strike, requiring the attacker to make a *Called Shot*, but even then the attacker is -4 to strike.

Destroying both sensor arrays knocks out the radar, targeting system and optics. This leaves the pilot to rely on his own human senses and eliminates any combat bonuses the sensors provided to strike, parry or dodge. **Note:** The sensor eyes are even smaller targets and require an attacker to make a *Called Shot* with a penalty of -5 to strike.

** M.D.C. plexiglass windows have 15 M.D.C. each. However, they also have metal alloy plates that slide into place in combat situations with the press of a button or voice command from the pilot. The metal plating provides each window with an additional 50 M.D.C.; the pilot drives via video images from the nose or hand sensor array and via instruments. An attacker needs to make a *Called Shot* to target a specific window, but suffers a penalty of -3 to strike. Destroying the M.D.C. of the window plexiglass and M.D.C. window shielding makes the Reinforced Pilot Compartment vulnerable to attack. When it is depleted to zero, the pilot and crew are vulnerable inside.

*** Depleting the M.D.C. of the main body will effectively destroy the robot, shutting it down completely, rendering it useless.

Speed:

Running: 35 mph (56 km).

Leaping: Not possible.

Special: The Ogre is very difficult to knock off its feet. Only body block/ram attacks from attackers of similar size and power have any chance, and even they attack at only one third the usual percentage for a knockdown. Attackers that are smaller or weighing less than 12 tons have no chance of knocking down the Ogre. Likewise, small attackers ramming the Ogre inflict half the usual damage to it, and suffer the same damage themselves; it's like slamming into the side of a mountain.

Water: Cannot swim, but can walk along the bottom of bodies of water at 20 mph (32 km). Maximum depth tolerance is 3,000 feet (914 m).

Flying: Not possible.

Statistical Data:

Height: 33 feet (10 m).

Width: 35 feet (10.6 m).

Length: Body: 30 feet (9.1 m) to the tip of the nose. The ion cannon adds another 4.5 feet (1.4 m).

Length: Arms: The hands would touch and drag across the ground like a gorilla if completely relaxed, and are usually held in a slightly raised position. The reach of the right arm is 30 feet (9.1 m). The reach of the left arm is 36 feet (11 m).

Weight: 42 tons.

Physical Strength: Equal to a Robot P.S. 45.

Cargo: In addition to the living quarters and minimal storage space they offer (the equivalent of a trunk and two foot lockers), there is an 8x4x8 foot (2.4 x 1.2 x 2.4 m) cargo closet for additional cargo and gear, and a specimen cabinet the size of a refrigerator. The cockpit has space for a rifle, backpack and basic gear in a luggage compartment above each seat.

Power System: Nuclear; average energy life is 20 years. Solid Oxide Fuel Cell system is an available alternative.

Cost: 35 million credits for nuclear power supply with a 15 year life, 28 million credits for Solid Oxide Fuel Cell; cannot use an electric battery system. Fair to good availability.

Weapon Systems:

1. NG-I17 Medium Ion Cannon (1): The nose gun is mounted on a turret that can rotate 180 degrees and has a 45 degree up and down arc of fire. It can be operated by the pilot or copilot. **Note:** Built into the turret is also a sensor array on the right side and a camera system on the left. Both are on the side and above the gun itself.

Primary Purpose: Defense.

Secondary Purpose: Assault and Anti-Personnel.

Range: 1,800 feet (548.6 m).

Mega-Damage: 4D6 M.D. per single blast.

Rate of Fire: Single shot only. Each shot counts as one melee attack.

Payload: Effectively unlimited.

2. NG-732 Pop-Up Mini-Missile Launcher (1, top): The low profile mini-missile launcher is located atop the Ogre near the left shoulder. The protective cover rises up to reveal the battery of launch tubes in order to fire. When done, the launcher goes back down. Can rotate 360 degrees and has a 60 degree up and down arc of fire.

Primary Purpose: Defense.

Secondary Purpose: Anti-Armor and Anti-Aircraft.

Range: One mile (1.6 km).

Mega-Damage: Varies with missile type. Usually high explosive (1D4x10 M.D.) or plasma (1D6x10 M.D.).

Rate of Fire: One at a time or in volleys of 2, 3 or 4.

Payload: 24 total. As a rule, an additional 24 are stored in the cargo hold. It takes 1D4+1 minutes for a trained crewman or Operator to reload; add six minutes for the untrained.

3. Defensive Flare Chaff Launchers (16 total; 8 per side): Located on each side of the Ogre are two batteries of four tube launchers (8 per side). The first four are loaded with flare chaff rockets. The second group contains smoke grenades.

Chaff Flares: The chaff rockets explode at a preset altitude or location indicated by the pilot, creating a cloud of sparkling light, bright flashes, chaff, foil and particles designed to fool incoming missiles and airborne flyers, including Gargoyles, dragons, other flying monsters, rocket bikes, jet pack troops, power armor and aircraft. Each tube fires one rocket, but several tubes can be fired in unison to create a larger and denser chaff cloud.

Primary Purpose: Anti-Missile.

Secondary Purpose: Anti-Flyers.

Range: 6,000 feet (1,829 m) high, into the air.

Chaff vs Missiles: The chaff cloud has a chance of causing missiles to explode before striking the Ogre or other nearby target. A single chaff cloud has a 10% chance of exploding any volley of missiles that enter the cloud. Increase the chance of success by 10% for each additional chaff rocket fired. Thus, a volley of two chaff rockets has a success rate of 20%, three rockets: 30%, four rockets: 40%, five: 50% and six (a maximum volley): 60%. Upon detonation of a missile or missile volley, the chaff cloud is destroyed and dispersed, but the incoming missiles are destroyed.

Chaff vs Aircraft and Flyers: Flying aircraft, power armor and beings caught in a chaff cloud momentarily have their vision impaired, sensors fouled and suffer the following penalties: -6 on Perception Rolls, -3 on initiative, -5 to strike, -2 to parry and dodge, and lose one melee attack for the rest of that round (or the next melee round if they enter or are caught inside a chaff cloud

at the end of a melee). Moreover, the chaff cloud temporarily negates any laser or optics-based targeting bonus and inflicts a -20% skill penalty to Sensory Equipment and Piloting for that melee round. Such penalties last for as long as the character is in the chaff cloud (typically only a second or two) and for the rest of that melee round for vision and sensor systems to recover (the next melee/15 seconds, if the character enters the cloud at the end of melee round). It has a similar effect to a Flash grenade.

Chaff Cloud Size: 30 foot (91.4 m) diameter cloud, increase an additional 10 feet (3 m) per each chaff rocket fired in the same volley. Only rockets fired in that volley count toward the detonation of incoming missiles (60% maximum).

Duration: The chaff cloud lasts two melee rounds or until destroyed.

Rate of Fire: One at a time or in volleys of 2, 3, 4, 5 or 6.

Payload: 16 total, two per launcher, per side.

Conventional Smoke Grenades: Smoke is effective in obscuring the vision of most monsters and supernatural beings.

Good for attempting a getaway, a diversion, concealing an attack or marking a position.

Primary Purpose: Defense.

Secondary Purpose: Position Marker.

Range: 1,200 feet (366 m).

Damage: Those caught inside a smoke cloud are blind, unable to see beyond their noses or what else is inside the cloud. Those standing outside a smoke cloud cannot see through the cloud and will not know what is happening on the other side of it unless they go through it, around it or over it (they cannot see what is in the cloud or on the other side). Smoke is excellent for concealing an escape or obscuring an impending attack. The same is true of fog.

Duration: The smoke cloud lasts 1D4+4 minutes; half in strong wind (25 mph/40 km) or greater).

Rate of Fire: One at a time or in volleys of 2, 3, 4, 5 or 6.

Payload: 16 total, two per launcher, per side.

4. Hand to Hand Combat: The Ogre is especially deadly in Mega-Damage hand to hand combat, as per Robot P.S. 45 and massive, powerful hands. See *Heavy Ground Robot Training* on page 352 of **Rifts® Ultimate Edition** for the number of attacks and bonuses. All abilities are as listed except as follows:

Restrained Punch – 1D6 M.D.

Full Strength Punch, Tear or Crush with Right Hand – 3D6+5 M.D.

Full Strength Punch, Tear or Crush with Left Hand – 3D6+9 M.D.

Power Punch with Right Hand – 1D6x10+7 M.D.

Power Punch with Left Hand – 1D6x10+12 M.D.

Spinning Hand/Drill Strike (Left) – 1D6x10+30 M.D.

Stomp Attack – 3D6 M.D., but is only effective against targets smaller than 8 feet (2.4 m) tall.

Head Butt – Not possible.

Leaps and Kicks – Not possible.

Ram/Body Block – Standard.

Note: Power Punches and the Spinning Hand Strike count as two melee attacks.

5. Sensor System Notes: All standard robot systems, plus the following:

A. Right Hand, Camera and Sensor Pod: Has an infrared and conventional light beam (1,000 foot/305 m range) and digital video camera that feeds directly into the crew compart-

ment. Live feed can be relayed to the living compartments and displayed on a screen over the bunk. The camera has a 6,000 foot (1,829 m) range with telescopic lenses as well as macro-lenses for seeing up-close, x10 magnification. Can store up to 10,000 hours of video footage before requiring transfer to some other medium. Includes image and video transmission capabilities. The sensor pod has all the standard sensor capabilities plus motion detection (100 feet/30.5 m).

B. Nightvision Optics: Passive light amplification that allows the pilot, gunner and communications officer to see in the dark as long as there is at least some ambient light. 2,000 foot (610 m) range, but is completely useless in total darkness.

C. Built-in Language Translator: Programmed with the nine known languages of the Americas and can hold 12 additional languages. It can recognize and monitor up to three different voices and two different languages or dialects. Level of accuracy is 98.7%, with a three second delay when directed at one individual, but drops to 78% with a six second delay when translating three speakers simultaneously.

D. Winch and Cable (2): Located in the back and on the left hand (concealed) is a winch, hook and tow line for pulling cargo, assisting other robots and vehicles, towing small boats and barges along the shore, and climbing.

EX-11 Okemos Explorer Robot

The Okemos, aka ‘Little Chief,’ comes from the NG Department of Exploratory Robot Designs. It was named by the head of Northern Gun Research and Development, **Federico Franceschi**. The exploration robot (and the pre-Rifts city of Okemos near the ruins of Lansing) is named after a Michigan Native American chief, *John Okemos*, of the Saginaw Chippewa people of the Ojibwa nation. In the Ojibwa language, *Ogimaans* – anglicized to ‘Okemos’ – means ‘Little Chief.’ Federico, fascinated with the pre-Rifts history of Michigan, thought it was appropriate to name his tough, small explorer robot after the famous Indian Chief and found it equally appropriate that the ancient Michigan city of Okemos was once a place of industrial manufacturing.

As a light, four-man robot vehicle, the Okemos is a multi-purpose ‘Bot designed for long stays in the wilderness and trekking across great expanses of hostile territory. Though the Little Chief has only two weapon systems with which to protect itself, it can be formidable in combat. The **Redapple Design Team**, lead by **Peter Adams, David Snell, and Chris Axtell**, wanted to create a comparatively small, fast, versatile robot that would be ideal for adventurers, explorers and wilderness travelers without breaking their bank account.

Indeed, the real advantage of the Okemos is its travel and exploration capabilities. The mighty, little robot walks on two legs, enabling it to navigate uneven ground, step or hop over barriers such as fallen trees, boulders and rock slides, and tromp through fields of tall grass, tangles of brush and thin forests, as well as wade through swamps, streams and bodies of water. Its pair of hydraulic arms have a maximum extendible reach of 12 feet (3.6 m) and can be used to pick up and carry specimens or supplies, climb, make repairs to other robots and large vehicles, and even engage in simple, hand to hand combat.

The forward cab is the pilot's cockpit with a large, M.D.C., bubble-like window. Though the window makes the driver vulnerable to attacks, adventurers and explorers have demanded the feature of a large, clear M.D.C. window rather than an armored compartment with a slit or no window at all. They want to be able to see the world they are traveling through. The window is Mega-Damage plexiglass (35 M.D.C. total). For those who want security more than a view, there is an optional plate cover (100 M.D.C.) with a narrow slit that can be attached to cover the glass bubble window. It takes 1D6+6 minutes and the proper tools to bolt on or remove.

On either side of the pilot's cockpit (top) is a spotlight/headlight that can angle 30 degrees in all directions. There is another, smaller light (3 M.D.C. each) in each of the shoulders as well as a digital camera (1 M.D.C. each). What some might mistake for a small weapons turret in the nose is a digital recording system capable of up to 8,000 hours of video, with sound, and has a telescopic, zoom lens with 12x magnification (6,000 foot/1,828 m range), and macro zoom that can get as close as 3mm and has 30x magnification. There is another camera in the main gun turret. All cameras send their feed to the pilot's HUD (Heads-Up Display) as well as monitors in the cockpit, main turret and sleeping berths.

The most appealing travel feature to adventurers and mercs is that the Okemos has four individual, environmentally sealed, sleeping berths/living quarters. Each has a bed that can fold into a recliner/easy chair, or made to lay flat for sleeping. A light panel is located above the bed/chair, as is a flat screen monitor for live camera feeds or recorded entertainment (music, films, etc.). Each private 'travel room' has all of the following: a small, stainless steel sink with a 100 gallon (378.5 liter) water supply (to be used sparingly), a mirror above the sink with a small medicine cabinet, a separate tank of drinking water (50 gallons/189.2 liters) with a built-in water purification and filtration system for new water supplies of unknown quality, two very small tables/counters that fold out from the wall and flat back into it, a chest-sized trunk at the foot of the bed for stowing personal gear that doubles as a seat, a small rack for hanging clothes, and a flushless toilet that disposes of waste via a light S.D.C. ion vaporization system (a fan pulls the odor of vaporized waste out of the tiny compartment, though an unpleasant odor almost always lingers for 3D6 minutes). Each of the sleeping berths also has two windows (15 M.D.C. each), but they have protective plates (40 M.D.C. each) that slide into place with the press of a button or voice command.

Weapon systems are limited to the nose rail gun turret and the top-mounted weapon turret. The nose gun can be an S.D.C. machine gun (silver ammo for fighting vampires and werebeasts is available), an M.D. rail gun or laser weapon, depending on what the purchaser is willing to spend. It is mounted into a turret that can rotate 180 degrees and has a 45 degree up and down arc of fire. The heavy weapon turret mounted on top of the sleeping quarters is also the housing for a second, major camera recording unit. There is also a spherical communications and sensor array with a spotlight.

As an exploration vehicle, the Little Chief has long-range communications, a laser relay system and full sensor capabilities. The turret has an open-air seat for the gunner/communications engineer. The open seat is ideal for quick, easy entry and exit. Though open in the front, the operator/gunner is obscured and protected by the turret, the armored control panel and the gun

itself, making him an extremely difficult target to pinpoint and hit (requires a "Called Shot" with a penalty of -6 to strike) and he can only be targeted at an angle from the side.

If there is a negative to the Okemos, it is that the robot is nose-heavy and bobs up and down a bit when it walks and runs. Some have complained that it's like riding a camel, but most adventurers get used to it in a few days. The Little Chief is sturdy, reliable and very popular among adventurers, explorers, mercenaries and even merchants who rip out the beds and use the sleeping berths as cargo bays.

Name: Okemos

Nicknames: Little Chief and NG Scout 'Bot.

Model Type: EX-11

Class: Exploration Robot; suitable for wilderness exploration, travel, scouting, long-range reconnaissance and light combat.

Crew: One pilot, with room for three passengers.

M.D.C. by Location:

Gun Turret (1, top, manned) – 125

** Turret Camera (1, top) – 10

* Turret Sensor Array (1, top, bubble shape) – 30

** Spotlights (4) – 6 each

** Nose Camera (1) – 10

* Nose Rail Gun (1) – 75

Shoulders of Utility Arms (2) – 100 each

* Utility Arms and Hands (2) – 50 each

Legs and Feet (2) – 190 each

Sleeping Berths (4, Rear Section) – 115 each

Berth Hatches (4) – 50 each

Berth Windows (8) – 15 each glass + 40 for sliding plate

M.D.C. Glass of the Pilot's Cockpit – 40

M.D.C. Snap-On Cockpit Plate Covering (Optional) – 100

*** Main Body (Forward Section) – 295

* A single asterisk indicates a small and difficult target to strike, requiring the attacker to make a "Called Shot," but even then the attacker is -3 to strike.

** Two asterisks indicates a very small or difficult target to strike, requiring the attacker to make a "Called Shot," but even then he is -4 to strike.

*** Depleting the M.D.C. of the Forward Section/Pilot's Cockpit shuts the vehicle down completely, making it useless. The M.D.C. glass of the pilot compartment has an M.D.C. of 35, but requires a "Called Shot" to target it specifically. Such attacks suffer a penalty of -2 to strike. When the glass (or plate covering and glass) is gone, the pilot is vulnerable, protected by only whatever body armor (typically 28-100 M.D.C.) or light power armor he may be wearing. To target the pilot requires a "Called Shot" with a penalty of -3 to strike.

Speed:

Running: 72 mph (115.2 km) maximum speed; 30-50 mph (48 to 80 km) is considered cruising speed. Speed is likely to be determined by the conditions of the environment, weather and terrain.

Leaping: The robot's powerful legs enable it to perform leaps and running leaping movement 20 feet (6.1 m) high and 30 feet (9.1 m) across.

Water: The Little Chief is not designed for use underwater, but can walk along the bottom at a speed of 30 mph (48 km). Maximum depth tolerance is a mere 800 feet (244 m).

Flying: Not possible.

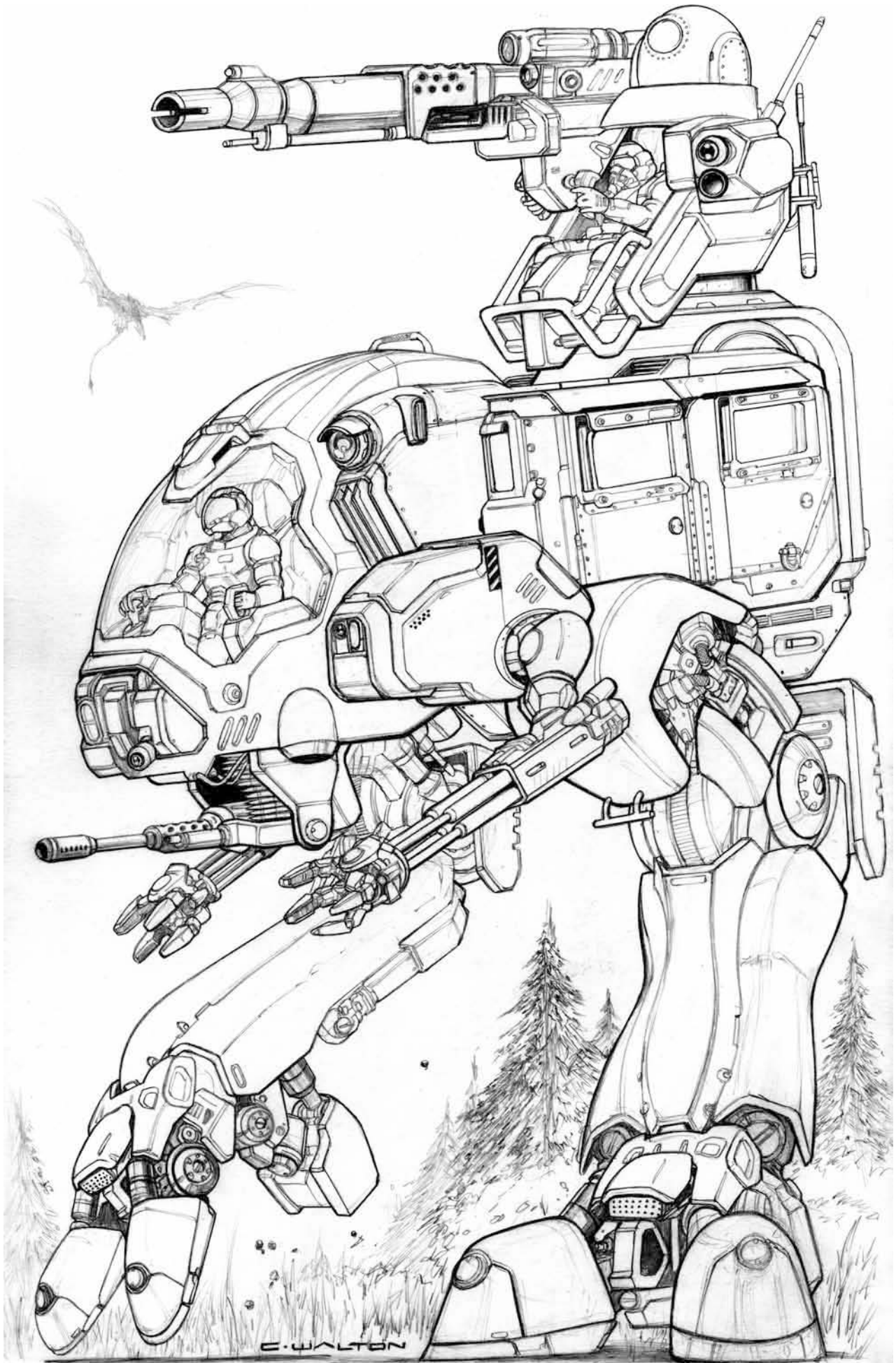

Statistical Data:

Height: 20 feet (6.1 m) from top of the cockpit to toe. The big gun adds another 6 feet (1.8 m) for a total height of 26 feet (7.9 m).

Width: 12 feet (3.6 m) at the hips.

Length: 17.6 feet (5.4 m).

Weight: 7.5 tons.

Physical Strength: Equal to a Robotic P.S. 30.

Cargo: Minimal, the chest-sized locker in the sleeping berths is 3x3x3 feet (0.9 x 0.9 x 0.9 m), plus some hangers and space to stow a few backpacks, a rifle, pistol, survival kit and personal items.

Power System: Nuclear; average energy life is 20 years. Solid Oxide Fuel Cell and electric battery versions are also available.

Cost: Nuclear: 18 million credits. Solid Oxide Fuel Cell: 12 million credits. Electric battery: 11 million credits.

Weapon Systems:

1. Main Gun Turret (1, top): Regardless of the weapon system selected, the turret needs to be manned by a gunner, can rotate 360 degrees, and has a 45 degree, up and down, arc of fire. It also has a camera, laser targeting, and sensor system mounted on the turret.

(Option A) NG-LC117 Heavy Laser Cannon (1): Excellent range and heavy firepower.

Primary Purpose: Anti-Personnel and Assault.

Secondary Purpose: Defense.

Range: 3,000 feet (914 m).

Mega-Damage: 4D6 per single blast.

Rate of Fire: Each blast counts as one melee attack.

Bonuses: +2 to strike.

Payload: Effectively unlimited.

Cost: 170,000 credits.

(Option B) NG-IC17 Ion Cannon: An ion cannon for superior damage but less range.

Primary Purpose: Anti-Armor and Assault.

Secondary Purpose: Anti-Personnel and Defense.

Range: 1,800 feet (548.6 m).

Mega-Damage: 6D6 M.D. per single blast.

Rate of Fire: Each blast counts as one melee attack.

Bonuses: +1 to strike.

Payload: Effectively unlimited.

Cost: 120,000 credits.

2. Nose Turret (1, front): Regardless of the weapon system selected, the nose gun can turn 180 degrees in a forward sweep, and has a 45 degree, up and down, arc of fire.

(Option A) Medium NG-217 Rail Gun Turret (1): A medium rail gun is used against dangerous ground animals, monsters and assailants. Like all rail guns, it can fire conventional rail gun rounds or silver-coated rounds or wood and silver rounds (see Gunwolf for details) to battle the supernatural. This is the typical choice as it provides versatility.

Primary Purpose: Assault & Anti-Personnel.

Secondary Purpose: Defense.

Range: Conventional rail gun rounds and silver-coated rounds: 2,000 feet (610 m). Special, weighted wood rounds with silver rings: 1,000 feet (305 m).

Mega-Damage: Varies. Standard & Silver Ammo: A standard M.D. burst is 60 rounds and inflicts 5D6 M.D. (+4 M.D. to opponents at point-blank range; within 10 feet/3 m) per burst. One round does 1-2 M.D.

Rate of Fire: Each single shot or burst counts as one melee attack.

Payload: 3,000 rounds total with enough ammo for 50 bursts.

Cost: 125,000 credits.

(Option B) NG-017 Heavy Machine-Gun (1): This is a heavy, S.D.C. machine that can fire used against non-M.D.C. threats, but is also effective against supernatural and magic creatures when using silver-coated rounds. The machine-gun has the advantage of a great payload, but little effect against Mega-Damage opponents.

Primary Purpose: Assault & Anti-Personnel.

Secondary Purpose: Defense.

Range: Conventional S.D.C. machine-gun rounds and silver-coated rounds: 3,000 feet (614 m). Special, weighted wood rounds with silver rings: 1,000 feet (305 m).

Damage: Varies. Standard & Silver Ammo: A short burst of 2-5 rounds does 2D4x10 S.D.C.; 20 round burst does 4D6x10 S.D.C./1 M.D.; and a 40 round burst inflicts 1D6x100 S.D.C./1D6 M.D. equivalent damage.

Rate of Fire: Burst fire only. Each burst counts as one melee attack.

Payload: 4,800 rounds total with enough ammo for 120 long bursts.

Cost: 60,000 credits.

(Option C) NG-127 Laser (1): A medium laser for range, power and an unlimited payload.

Primary Purpose: Anti-Personnel and Assault.

Secondary Purpose: Defense.

Range: 2,000 feet (610 m).

Mega-Damage: 4D6 M.D. per simultaneous triple blast.

Rate of Fire: Each triple blast counts as one melee attack.

Payload: Effectively unlimited.

Cost: 140,000 credits.

(Option D) Box Mini-Missile Launcher (1): The nose gun is replaced by a box mini-missile launcher turret.

Primary Purpose: Anti-Armor and Anti-Missiles.

Secondary Purpose: Anti-Personnel and Defense.

Range: One mile (1.6 km).

Mega-Damage: Varies with missile type. Usually fragmentation (5D6 M.D.) or plasma (1D6x10 M.D.).

Rate of Fire: One at a time or in volleys of 2, 3 or 4.

Payload: 12 total.

Cost: 100,000 credits, plus cost of the mini-missiles. (Generally cost 1,200-2,500 credits each depending on type. See page 257 of **Rifts® Ultimate Edition** for prices).

3. Hand to Hand Combat: Rather than use a weapon, the pilot can engage in Mega-Damage hand to hand combat as per *Robot P.S. 30*. However, the Little Chief is NOT designed for fighting. See *Light Ground Robot Training* on page 353 of **Rifts® Ultimate Edition**, but reduce the bonuses by half, round down.

4. Sensor System Note: Standard for robots, plus long-range radio and multiple cameras.

Cameras (4): Two main camera systems are built into the robot. One in the nose (above the weapon turret) and one in the main cannon. There is also a small camera built into each shoulder. All cameras are protected from blast shock with a combination of high and low acoustic impedance and shock dispersal materials. The internal hard lenses are made of a material that turns them into a gel with a plastic outer enclosure upon impact, and once the shock dissipates, a small electric current automatically reforms the lenses to their hard state.

When mounted in heavy robots or armored vehicles, any bumps or minor impacts initiate an automatic image stabilization system. A direct hit on a camera is highly unlikely.

The most common cameras have an internally adjustable, 28-600mm telephoto lens with automatic focusing. Normal human vision is considered about 50mm, so any number below that provides for a wider than normal angle of view. At 300mm, distant objects are magnified by a factor of 6x. A separate 600mm camera, also with auto-focus, provides a magnification of 12x. (**Note:** This is the type used by wildlife and sports photographers.)

The cameras installed in the robot can store 4 million still photographs or 8,000 hours of video with sound, or a combination of the two. As digital files, they can be downloaded to video disks and other data storage media in order to free space in the camera. Photos and video can also be transmitted to proper receivers like a radio transmission.

NG-EX-V50 Scorpion Battler

The NG-EX-V50 Scorpion is something of a departure and experiment for Northern Gun, inspired by the Coalition States' *Scorpion Skull-Walker* and the success of Bandito Arms' *Tarantula ATR*. The Tarantula is so popular, in fact, that it has been knocked off by both **Titan Robotics** under the name *Spider* and the **Manistique Imperium** under the name *Black Widow*; both of which are selling very well. Highly competitive, a Northern Gun design team lead by **Doug Roy, Brian Terrill, Orion Pobursky, Carmen Bellaire** and **Sam Beedah** decided to outdo Bandito's Tarantula with their own version of a full combat, insect-styled robot.

Ever mindful of creating robot vehicles with multiple functions that can satisfy military applications along with exploration and adventuring, the **NG Scorpion Battler** is an eight-legged (counting the pincers), all-terrain robot that provides diverse functionality. It only requires a two man crew to operate, but accommodates four additional passengers and has a barracks-style sleeping area with bunks, plus small kitchen and dining room, toilet (with ion vaporization waste disposal system) and small shower; all features that appeal to adventurers out in the field for long periods of time.

Patterned after a real scorpion, the EX-V50 features a revolutionary articulated weapons tail (only the Coalition military has a similar weapons system) and a pair of massive pincers. **The tail** is a multi-weapon platform that houses the main energy cannon, a pair of lasers, a secondary mini-missile launcher, two spotlights (one on each side of the gun) and a gun camera. On its back, behind the cockpit, is a weapon turret for additional hitting power. **The left pincer** can be used to crush ground troops, grab and hold light vehicles and power armor or tear out barbed wire and fencing as well as punch through defensive walls and brush away human-sized forces. **The right pincer** is not a true pincer, but rather a large cutting tool suitable for slicing through doors, walls, fences and fortifications, as well as fighting other robots and armored vehicles in close combat. Of course, both pincers are useful in construction operations, building, cutting down trees and lumber, digging trenches and foundations, chopping-up sal-

vage and cargo hauling. A digital video camera is built into each pincer, the turret and the tail, providing live feeds sent to the crew via Heads-Up Displays (HUDs) and internal monitors, as well as the capacity to transmit video to other units and field command. Another 'tool' is the backhoe that unfolds from the nose section of the Scorpion, good for digging trenches or general earthmoving operations.

The Scorpion Battler was one of NG's new releases in the Spring of 109 P.A., but is already getting good buzz among adventurers, explorers and mercenaries as a dependable, versatile and flexible combat and exploration vehicle. Many like that it rides low to the ground compared to most other robots. And the fact that real scorpions are animals to be feared adds to its appeal for many customers. Like the Tarantula, the Scorpion Battler looks cool – and cool always sells!

Model Type: EX-V50

Class: All-Terrain Robot Combat Vehicle.

Crew: One pilot and a dedicated gunner, with room for four passengers comfortably, 6-8 cramped.

M.D.C. by Location:

Tail – 230

Tail Gun Platform (multiple weapons) – 200

* Tail Spotlights (2) – 5 each

Top Weapon Turret (1, multiple weapons) – 220

Right Pincer, Chainsaw (1) – 200

Left Pincer (1) – 300

** Legs (6) – 200 each

* Cameras (4; turret, tail and both pincers) – 12 each

* Nose Backhoe (1, folding) – 100

* Nose Headlights (2) – 8 each

* Nose Sensor Array (1) – 35

* Windows of Pilot Cockpit – 25 each

Reinforced Pilot Compartment – None

** Window Plates (8) – 50 each

*** Forward Section (cockpit) – 300

*** Midsection/Main Body/Passengers – 350

* A single asterisk indicates a small and difficult target to strike, requiring the attacker to make a "Called Shot," but even then the attacker is -4 to strike.

** The Scorpion Battler can lose two legs without any reduction in speed, even if the loss is on the same side. The loss of three reduces speed by 30% and inflicts a -15% piloting penalty when the loss is divided between both sides. Meaning one side has one leg remaining and the other has two. When the Scorpion loses three legs on the same side, it drags on that side. Reduce speed by 70%, -40% piloting penalty, -2 on initiative and parry, and -1 melee attack. Note: As long as it has one leg on each side, it can continue to crawl along at half speed and suffers a -30% piloting penalty.

*** Destroying the *forward section* – or what some people might consider the head (where the cockpit is located) – immobilizes the entire robot. The pincers, backhoe, cockpit controls, legs and main sensor array are all knocked out and dead. The robot cannot walk, but it is *not* dead.

Important Combat Note: The Midsection/Passenger Compartment is the Main Body where the power supply is located, and it remains up and running even if the forward section is destroyed. This means the *weapon turret* on top as well as the *tail* and *tail weapons platform* ALL remain functional and able to continue to fight. The turret can rotate 360 degrees,

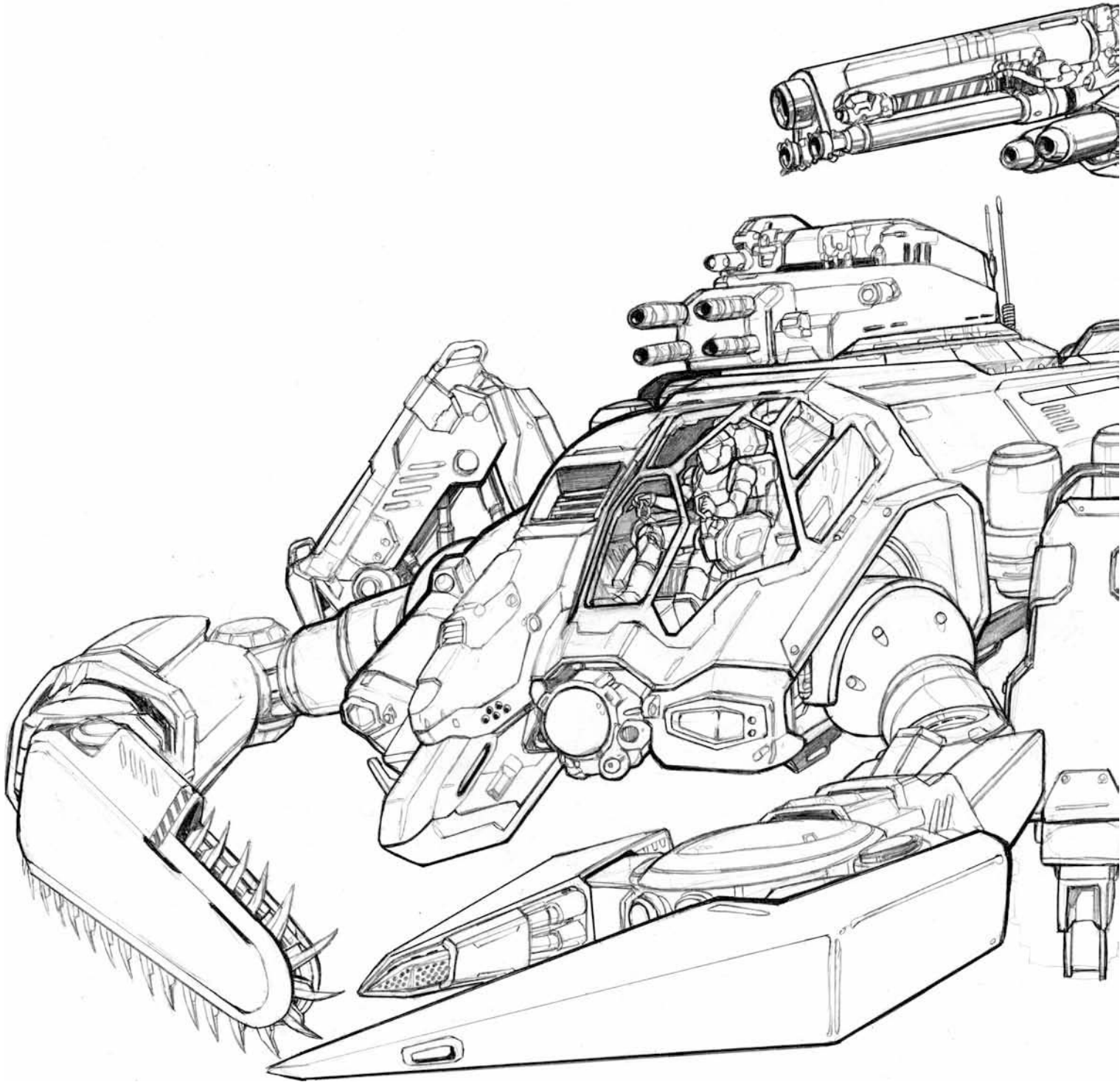

the tail can move and all weapons can fire. The weapon turret also has a secondary sensor and communications system with half the standard range, and a camera that also remains working. The M.D.C. of the midsection must be reduced to zero to “kill” the Scorpion and take away its sting. The gunner is located inside the top turret.

M.D.C. plexiglass windows have 25 M.D.C. each. However, they also have metal alloy plates that slide into place in combat situations with the press of a button or voice command from the pilot. The metal plating provides each window with an additional 50 M.D.C.; the pilot drives via video images from the nose or hand sensor array and via instruments. An attacker needs to make a *Called Shot* to target a specific

window, but suffers a penalty of -3 to strike. Destroying the M.D.C. of the window plexiglass and M.D.C. window shielding makes the pilot and crew vulnerable to attack.

Speed:

Running: 60 mph (96 km) maximum.

Leaping: Not possible.

Special: The Scorpion is impossible to knock off its feet, knock-down or roll over. Likewise, small attackers ramming the Scorpion Battler suffer the same damage themselves that they inflict upon the robot.

Water: Cannot swim, but can walk along the bottom of bodies of water at 25 mph (40 km). Maximum depth tolerance is 2,000 feet (610 m).

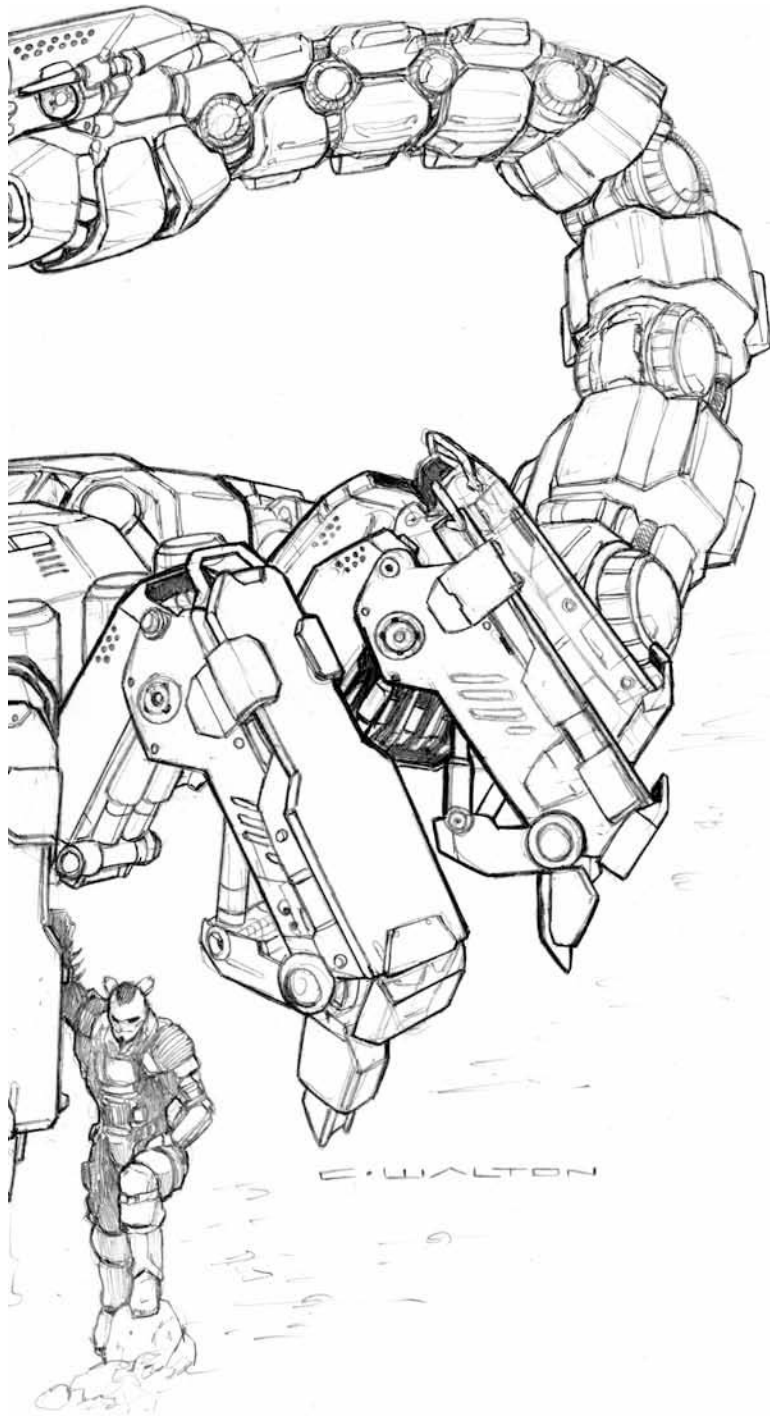

Flying: Not possible.

Statistical Data:

Height: 16 feet (4.9 m) low to the ground and with the tail curled and held at turret height off to one side or the other. 22 feet (6.4 m) with tail curled over the main body and turret. There is four feet (1.2 m) of clearance *under* the robot when it is walking.

Width: 18 feet (5.5 m).

Length: 22 feet (6.7 m) from tip of the nose to the end of the Main Body. The tail curled up (standard position) adds another 12 feet (3.6 m) and the pincers add another 5 feet (1.5 m), but have a 15 foot (4.6 m) reach. The tail laid flat behind the robot is 36 feet (11 m) long.

Weight: 28 tons.

Physical Strength: Robotic P.S. of 45.

Cargo: In addition the living quarters and minimal storage space they offer (the equivalent of a trunk and one footlocker for each berth), there is an 8x4x8 foot (2.4 x 1.2 x 2.4 m) cargo closet for additional cargo and gear, and a specimen cabinet the size of a refrigerator. The cockpit has space for two rifles, two backpacks, an extra suit of body armor (the pilot usually wears heavy body armor or light power armor) and basic gear in a luggage rack behind the seat. The weapon turret has similar space for the gunner.

Power System: Nuclear is standard, but a Solid Oxide Fuel Cell system is also available.

Cost: 38 million credits for a nuclear power supply with a 15 year life, 30 million credits for a Solid Oxide Fuel Cell; cannot use an electric battery system. Fair to good availability.

An Explorer Scorpion: The **EX-EC49 Scorpion Wanderer** is an *explorer and construction model* with no weapon turret and only a medium laser (4D6 M.D. per single shot, 2,000 foot/610 m range) and Vibro-Blade (3D6 M.D.) built into the tail. Speed is a bit faster at 70 mph (112 km), and all other stats, pincers and features are the same. It is available for 28 million credits nuclear or 22 million credits for Solid Oxide fuel Cell. Fair availability.

Weapon Systems:

1. Tail Multi-Weapon Platform (1, multiple weapons): The main weapon platform is built into the end of the scorpion tail. Since the tail is completely articulated, it can be made to point in any direction, including up, down, side to side, front and back. The tail is usually held in a curled forward combat position. In addition to firing any one of its three weapons or spotlights (2,000 feet/610 range), the tail can also be used to swat and hit opponents (-1 to strike man-sized opponents smaller than 7 feet/2.1 m); see Hand to Hand Combat for tail damage.

Ion Cannon (1, top): The large gun barrel is a heavy ion cannon with excellent range for a weapon of its type. Point the tail and shoot. It can be fired by itself or in linked fire with the two laser cannons under it.

Primary Purpose: Assault and Anti-Armor.

Secondary Purpose: Anti-Monster and Defense.

Range: 2,000 feet (610 m).

Mega-Damage: 1D4x10 M.D. per single blast. Linked fire from it and the two lasers is also possible, provided the target is within range of the ion cannon. See damage numbers under Dual Laser Cannons.

Rate of Fire: Each single or linked blast counts as one melee attack.

Payload: Effectively unlimited. **Note:** There is also a gun camera and two spotlights (one on each side of the ion cannon).

Dual Laser Cannons (2, top): The two long, thin barrels running along the ion cannon are laser cannons that provide superior range.

Primary Purpose: Assault and Anti-Personnel.

Secondary Purpose: Anti-Fliers and Anti-Missile.

Range: 4,000 feet (1,219 m).

Mega-Damage: 3D6 M.D. per single blast, 6D6 M.D. per simultaneous double blast. Linked fire from the lasers and the ion cannon is possible for a total of 1D6x10+15 M.D.

Rate of Fire: Each single or paired laser blast or triple linked blast with the ion cannon, counts as one melee attack.

Payload: Effectively unlimited.

Tail Mini-Missile Launch Tubes (2): Designed to supplement the primary mini-missile launcher and to knock down incoming enemy missiles and flyers.

Primary Purpose: Anti-Aircraft and Anti-Missile.

Secondary Purpose: Anti-Armor and Anti-Robot.

Range: 1 mile (1.6 km).

Mega-Damage: Varies with missile type. Any mini-missile can be used, but it comes standard with armor piercing (1D4x10 M.D.) or plasma (1D6x10 M.D.). Fragmentation (5D6 M.D.) may be used for anti-personnel operations.

Rate of Fire: One at a time or in volleys of two.

Payload: 8 total mini-missiles can be fired from the tail.

Bonus: +1 to strike for the missiles.

2. Top-Mounted Weapon Turret (1, multiple weapons): The turret can rotate 360 degrees and includes a forward-facing camera, a short-range laser (top, side) and four mini-missile launch tubes. It also houses the secondary sensor and communications system. **Note:** The gunner is seated completely self-contained inside the turret. He operates the weapon systems of the turret and the tail. The pilot operates the robot and controls the pincers, but depending on the circumstances, he can take over the tail weapons from the gunner so both main weapon platforms can be directed at two or more targets or different areas of the battlefield.

(Option A) Main Gun: Quad Mini-Missile Launcher:

All of the four launch tubes are forward-facing but have a 30 degree up and down arc of fire. This is the standard weapon for the turret.

Primary Purpose: Anti-Armor/Anti-Robot.

Secondary Purpose: Anti-Aircraft/Anti-Missile.

Range: 1 mile (1.6 km).

Mega-Damage: Varies with missile type. Any mini-missile can be used, but it comes standard with armor piercing (1D4x10 M.D.) and plasma (1D6x10 M.D.); payload is half of each.

Rate of Fire: One at a time or in volleys of 2 or 4.

Payload: 40 total, ten mini-missiles per tube; automatic full reloads.

Bonus: +1 to strike for the missiles.

(Option B) Main Gun: Rail Gun: The quad mini-missile

launchers can be replaced by a heavy rail gun. Forward-facing but has a 30 degree arc of fire up and down or side to side arc.

Primary Purpose: Assault and Anti-Personnel.

Secondary Purpose: Defense.

Range: 4,000 feet (1,219 m).

Mega-Damage: 1D6x10 M.D. per 60 round burst.

Rate of Fire: Each burst counts as one melee attack.

Payload: 6,000 rounds (100 bursts).

(Option A) Secondary Weapon: Medium Laser (1): A

snub-nosed laser is mounted in the top right side of the turret. It has a 45 degree up and down, and a 30 degree side to side, arc of fire. This is the standard weapon that comes on the turret.

Primary Purpose: Defense.

Secondary Purpose: Anti-Personnel.

Range: 2,000 feet (610 m).

Mega-Damage: 3D6 M.D. per blast.

Rate of Fire: Each single blast counts as one melee attack.

Payload: Effectively unlimited.

(Option B) Secondary Weapon: Ion Blaster: A snub-

nosed ion blaster is mounted in the top right side of the turret.

It has a 45 degree up and down, and a 30 degree side to side, arc of fire.

Primary Purpose: Defense.

Secondary Purpose: Anti-Personnel.

Range: 1,200 feet (366 m).

Mega-Damage: 5D6 M.D. per blast.

Rate of Fire: Each single blast counts as one melee attack.

Payload: Effectively unlimited.

3. Right Pincer M.D. Chainsaw (1): The right pincer has a massive, heavy-duty cutting tool. To call it a chainsaw is a disservice, as it is designed to cut through wood, lumber, roots, dirt, stone, wire and M.D.C. concrete and metal. The saw is built into a flipper that can bend from one side to the other 180 degrees, and can rotate to cut at all angles.

Primary Purpose: Cutting/Construction and Anti-Fortification.

Secondary Purpose: Assault and Defense.

Range: Touch/close combat. The arm has a 15 foot (4.6 m) reach. The saw itself is six feet (1.8 m) long on one side and three feet (0.9 m) on the other.

Mega-Damage: The chainsaw does 1D6x10 M.D. per attack, and even when turned off it does 4D6 M.D. with its dagger-like sawteeth. A full strength punch/swat with the blunt side (includes Robot P.S. consideration) does 3D6 M.D. **Note:** The chainsaw is a modular unit that can be easily replaced with a chainsaw that has *silver sawteeth* to battle supernatural beings vulnerable to silver. The problem is that the silver plating is destroyed after 2D4 uses against M.D.C. armor, so it is best to swap out the chainsaw unit on an as-needed basis depending on the anticipated opposition.

Combat Note: A power punch/attack is NOT possible with this weapon.

Payload: Effectively unlimited.

4. Left Pincer (2): This pincer is used for grabbing, lifting, carrying, crushing, digging (with its large top claw), and tearing down walls. It can also be used to uproot small and medium trees, move or roll over stalled vehicles and debris, and in combat to hit, swat, and even impale other robots and enemy troops with its larger pincer that tapers into a sharp point. **Note:** Both pincers can be positioned to strike mid-body or the legs and feet when fighting other giant robots and opponents, and the robot has a *special tripping attack* (below). The Scorpion is not likely to be able to reach the head or shoulders of most giant opponents taller than 12 feet (3.6 m) with its pincers, but can hit such targets with its tail (see Hand to Hand Combat).

Primary Purpose: Construction and Cargo Hauling.

Secondary Purpose: Anti-Fortifications and Combat.

Range: Touch/close combat; 15 foot (4.6 m) reach.

Mega-Damage (includes Robot P.S. consideration):

Restrained Punch/Jab – 1D6 M.D.

Full Strength Punch, Tear or Crush – 3D6+3 M.D.

Power Punch – 1D6x10+6 M.D.

Power Punch Impalement – 1D6x10+12 M.D.

Tripping with Pincers (special) – The attack counts as a strike that must be parried or dodged; usually dodged as it is aimed at the lower legs and feet of giant opponents. Failure to parry or dodge means a successful trip that knocks an opponent off his/its feet. No damage is inflicted, but the victim of tripping loses initiative and two melee attacks. And is vulnerable to additional attacks from the Scorpion via its cutting pincer, weapon turret or weapons in the tail.

Climbing Attack (special) – Once an opponent has been knocked down, the Scorpion Battler can attempt to climb onto the prone opponent to pin him down with the weight of its own body and continue to attack with its pincers and weapon tail.

First the target must be knocked off its feet and in a prone position, lying flat on its back or face. The victim of knockdown and the Scorpion *both re-roll for initiative* with the Scorpion getting a +2 bonus on initiative. High roll wins. Add any applicable bonuses. If the victim wins, he gets back up on his feet and continues to fight or run away. The victim has avoided getting pinned down, but either way, still loses two melee attacks from being knocked down.

If the Scorpion Battler wins the initiative, it manages to climb on top of the fallen opponent and may continue to attack with pincers and tail weapons for the rest of the melee round. Depending on the opponent's body design, he/it may still be able to attempt to parry the Scorpion's attacks, but dodging is impossible, and the Scorpion, who has the advantage, is +2 to strike. NEXT MELEE ROUND, the victim can *attempt* to push the Scorpion Battler off enough to roll or squirm out from under the massive robot. This is only possible if the victim has no less than a Robotic P.S. 40 (or Supernatural P.S. 30), weighs at least half as much as the Scorpion, and bests the Scorpion in the initiative roll for the new melee round. (**Note:** To attempt to get out from under the Scorpion, both the victim and the Scorpion re-roll initiative at the beginning of each new round until success is achieved. However, such an attempt, success or failure, uses up two melee attacks of the victim.) Moreover, the Scorpion gets a +2 bonus on initiative and to strike, parry, dodge and all combat maneuvers against the pinned victim due to its superior position and leverage of being on top. Rather than struggle to get away, a victim pinned down might fare better to attack the Scorpion as best he can, targeting the vulnerable front section or even the midsection.

5. Hand to Hand Combat: The NG Scorpion is especially deadly in Mega-Damage hand to hand combat, as per Robotic P.S. 45 and massive, powerful pincers; see Pincers, above, for their attacks and damage. See *Heavy Ground Robot Training* on page 352 of **Rifts® Ultimate Edition** for the number of attacks and bonuses. All abilities are as listed on that page except as follows:

Punch or Tear (special) – See Pincers, above.

Tail Punch or Swat (special) – 4D6 M.D. (Cannot power punch with tail.)

Stomp Attack – 1D6 M.D., but is only effective against targets smaller than 7 feet (2.1 m) tall.

Head Butt – Not possible.

Leaps and Kicks – Not possible.

Ram/Body Block – Standard.

Note: Also see #3 and 4, above, for pincer and special attacks. *Power punch* and *tripping attacks* with the pincers count as two melee attacks.

6. Sensor System Notes: The sensor pod in the nose has all standard robot systems. The secondary communications and sensor system in the weapon turret has redundant systems at half the standard range. Plus the following additional systems:

A. Cameras: Four digital video cameras send live feeds directly into the cockpit, weapon turret and passenger compartment. Live feeds can be relayed throughout the robot and displayed on monitors, HUDs and a screen over each bunk. Each camera has a 4,000 foot (1,219 m) range with telescopic

lenses as well as macro-lenses for seeing up-close, x10 magnification. Can store up to 10,000 hours of video footage before requiring transfer to some other medium. Includes image and video transmission capabilities and standard sensor capabilities plus motion detection (100 feet/30.5 m).

B. Nightvision Optics: Passive light amplification that allows the pilot and gunner to see in the dark as long as there is at least some ambient light. 2,000 foot (610 m) range, but is completely useless in total darkness.

C. Built-in Language Translator: Programmed with the nine known languages of the Americas and can hold 12 additional languages. It can recognize and monitor up to three different voices and two different languages or dialects. Level of accuracy is 98.7%, with a three second delay when directed at one individual, but drops to 78% with a six second delay when translating three speakers simultaneously.

D. Winch and Cable (2): Located both in the rump section of the tail and up front in the nose (concealed) is a winch, hook and towline for pulling cargo, assisting other robots and ground vehicles, and climbing.

NG-SE48 Sunfire

The Sunfire is a compact robot vehicle perfect for patrolling borders and frontiers and defending remote communities. Though it looks much like any other humanoid-shaped combat robot, the Sunfire contains several experimental systems being offered for the very first time from Northern Gun. It comes from the **BGJP R&D design group** with major contributions from **Scott Kendrick, Albert Rosado, Lawson Stevenson, Mark Dudley** and **Carl Gleba**. The robot is equipped with an experimental energy system made up of solar panels that recharge the electric battery; something that has never been tried on the scale of a full-sized combat robot. A Solid Oxide Fuel Cell system is the backup and supplemental power supply, but if the solar panel system is deployed properly and is not damaged, the backup fuel cells should never be needed. Other innovations include a water-collecting cistern and purification system as well as holographic decoys used to harass and deceive the enemy. These innovations enable a cagey pilot to run circles around enemy forces and operate in the field for weeks without the need for resupply.

The Sunfire's main weapon is also a departure from the norm for a Northern Gun laser cannon and has a distinctive appearance. New designs have enabled NG to create a long-range laser with a much shorter barrel than is usual. The laser is connected to the solar panel array that transmits and stores energy to an independent, high-capacity electric battery system exclusive to the cannon. Mounted behind the head is the new, variable bore rail gun that can accept and fire virtually any sized rail gun ammo, from standard Northern Gun 202 rounds to various Coalition, Triax and even foreign rail gun ammo types.

As is so often the case, the Sunfire is designed to function as both a combat robot and as a vehicle suitable for exploration and adventuring. The pilot and passengers sit inside the chest area, while the robot's head actually contains an advanced sensory and communications package, as well as two head cameras. The Sunfire's comparatively small size, heavy armor, low cost, versatility and unique features have made it popular amongst NG's new robot line released in the Spring of 109 P.A. Even NG has

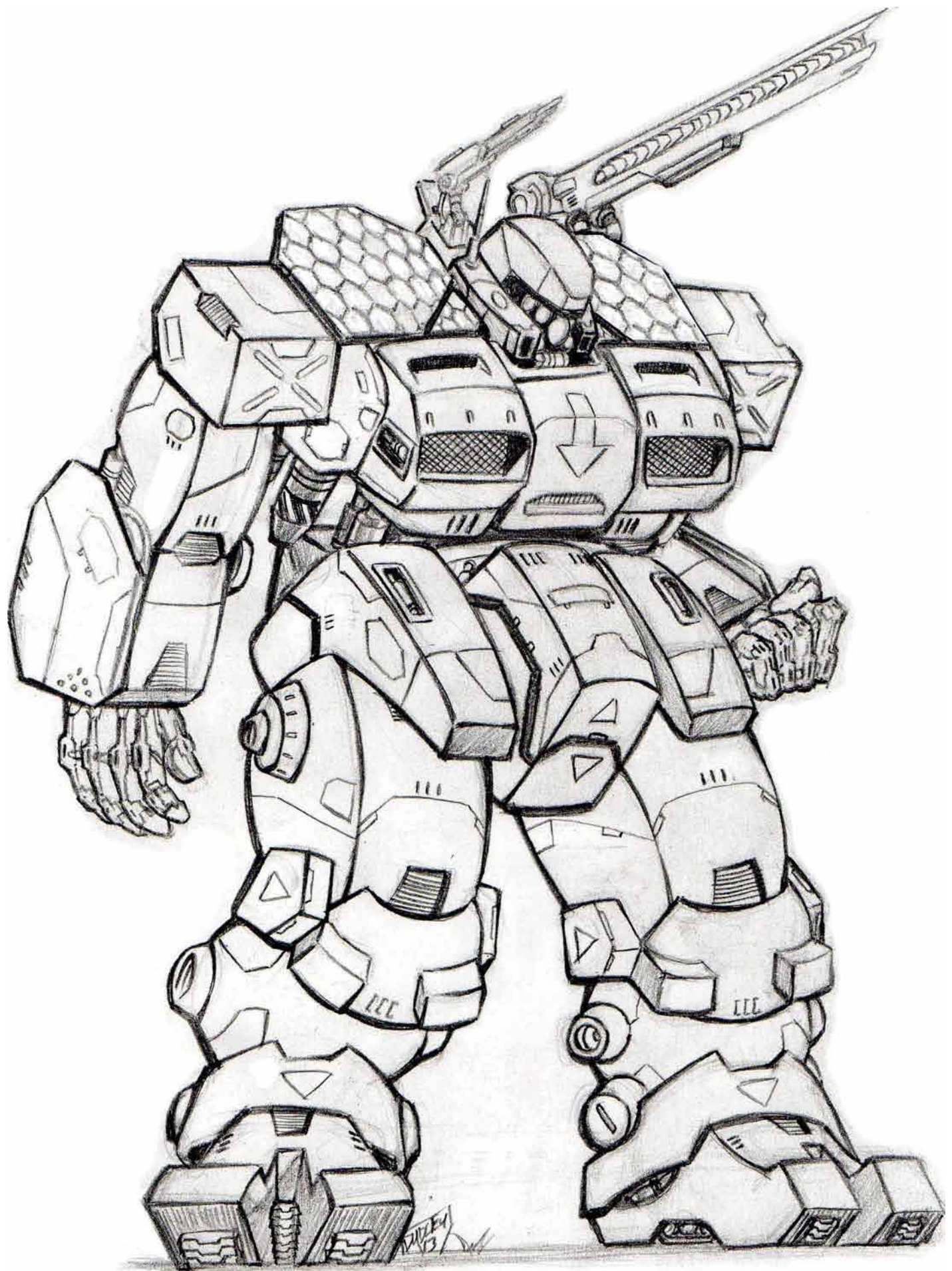

been surprised by how many customers are excited about the solar panel energy system. The Sunfire packs a punch and is a relatively small and inexpensive robot vehicle with both combat and wilderness travel capabilities, a combination that has adventurers delighted.

Model Type: NG-SE48 Sunfire.

Class: Solar Electric Exploration and Combat Robot.

Crew: One pilot with tight space for two passengers, one of which can operate the variable bore rail gun, if allowed by the pilot.

M.D.C. by Location:

- * Sensor Head – 100
- * Solar Panel Array (6 when unfolded) – 50 per each panel
- * Nova Laser Cannon (1, right shoulder) – 120
- * Rail Gun (1, behind head) – 60
- * Shoulder Mini-Missile Launchers (2) — 50 each
- Upper Arms (2) – 150 each
- Forearms (2) – 120 each
- Forearm Extra Plating (2) – 80 each
- Hands (2) – 90 each
- Legs (2) – 190 each
- Feet (2) – 120 each
- Reinforced Pilot Compartment – 100
- ** Main Body – 300

* A single asterisk indicates a small and difficult target to strike, requiring the attacker to make a “Called Shot,” but even then the attacker is -3 to strike.

Destroying the head knocks out all sensors and communications. The pilot must use his own vision, relying on images from the gun cameras built into the laser cannon and rail gun.

** Depleting the M.D.C. of the main body will shut the vehicle down completely, making it useless.

Speed:

Running: 70 mph (112 km) maximum.

Leaping: Five feet (1.5 m) high and 12 feet (3.6 m) across.

Water: The Sunfire is not designed for use in water, but can walk along the bottom of lakes and seas at a speed of 25 mph (40 km). Maximum depth tolerance is 1,000 feet (305 m).

Flying: Not possible.

Statistical Data:

Height: 19 feet (5.8 m) with laser cannon level and pointing forward.

Width: 9.6 feet (3 m).

Length: 7.5 feet (2.3 m).

Weight: 16 tons.

Physical Strength: Equal to a Robotic P.S. 35.

Cargo: Minimal, a small locker with enough room for a rifle, pistol, survival kit and a few personal items.

Power System: Solar-electrical (new and experimental) with a Solid Oxide Fuel Cell system as backup. Anticipated energy life is 12 years. The electric batteries automatically recharge using the solar panels; requires 24 hours of exposure to sunlight while the robot is completely inactive to fully recharge the batteries. Once full charged, the robot can function at full capacity for 48 hours. Of course, the idea is to have the solar panel array unfolded and drinking in energy while the robot is traveling or sitting idle to keep the batteries charged at all times.

Cost: Nuclear is NOT an available option (though the robot can be customized after purchase to change to a nuclear power pack

for the cost of 1D4+6 million credits depending on the provider). Solar electric with Solid Oxide backup: 17 million credits. **Note:** It costs 150,000 to replace one solar panel (there are 6 panels total).

Weapon Systems:

1. Solar-Powered Laser Cannon: In order to keep its overall price low, the Sunfire makes use of an electric battery power system. To make up for this, its primary weapon is tied into the solar power array and normally soaks up most of the juice the solar panels provide.

Primary Purpose: Anti-Armor.

Secondary Purpose: Anti-Aircraft.

Range: 3,000 feet (914 m).

Mega-Damage: 1D4x10 M.D.

Rate of Fire: Each blast counts as one melee attack/action.

Payload: 160 blasts when the independent solar battery pack is fully charged. The solar panel array requires one hour of time in direct sunlight to recharge enough energy for each blast. The flip of a switch can tie the weapon into the Solid Oxide Fuel Cell system for effectively unlimited firepower until it runs out of juice.

2. NG-VBR048 Variable Bore Rail Gun: A new type of rail gun that can fire almost any type of rail gun round, adjusting to most sizes and shapes. Cannot fire grenades, mini-missiles, explosive shells or other projectiles with fuses or moving parts. Possible ammo includes all known types of Earth rail gun rounds, and most alien and unknown rounds, including S.D.C. machine-gun ammunition.

Primary Purpose: Anti-Personnel and Anti-Monster.

Secondary Purpose: Defense and Anti-Aircraft.

Range: 4,000 feet (1,219 m), half that range when firing S.D.C. ammo and truly oddly shaped alien rounds.

Mega-Damage: A burst is 40 rounds and inflicts 6D6 M.D. One round does 1D4 M.D.

Rate of Fire: Each single shot or burst counts as one melee attack.

Payload: 4,000 round drum, enough for 100 bursts.

3. NG-M009 Mini-Missile Pod: A mini-missile launcher is built into each shoulder. The lid pops open and the missiles are fired.

Primary Purpose: Anti-Aircraft and Anti-Missile.

Secondary Purpose: Assault and Defense.

Range: 1 mile (1.6 km).

Mega-Damage: Varies with the missile type used. Usually Plasma (1D6x10 M.D.) or A.P./Heat rounds (1D4x10 M.D.), but any type can be used.

Rate of Fire: One at a time or in volleys of 2 or 4.

Payload: 18 total, nine per shoulder.

4. NG-RHD-48 Holographic Decoys (4): The Sunfire comes with 4 holographic decoys, each roughly the size of a toaster. They are holographic projectors that project three-dimensional images of a Sunfire robot in action. The exact portrayal of the image varies with the situation and can be static (standing still looking tough or just turning its head or weapons as if looking around) or active (appears to be walking back and forward, targeting, even firing the laser). The most convincing are static holographic images from a distance.

When deployed, the decoys emit a 3D holograph of the robot that lasts for 60 minutes until the battery is depleted. The idea is to trick potential spies and enemies observing from a distance into believing there are more Sunfires than there re-

ally are, standing guard or walking around. Of course, holographs are easily revealed for what they are via sensors as they do not appear on radar or motion detectors, magnetometer readings or thermal-imaging systems, and infrared and ultraviolet optics see right through them. The decoys do not work underwater.

Primary Purpose: Intimidation and Deception.

M.D.C. of Projectors: 6 M.D.C. each

Range: 300 feet (91.4 m) from projector.

Mega-Damage: None.

Duration: Holographic image will run for one hour; rechargeable battery with charging station inside the Sunfire robot.

Payload: Four holographic decoys come standard with the Sunfire. Each must be placed by hand.

Cost: 15,000 per holographic decoy.

5. Hand to Hand Combat: Rather than use a weapon, the pilot can engage in Mega-Damage hand to hand combat as per Robotic P.S. 35. See *Light Ground Robot Training* on page 353 of **Rifts® Ultimate Edition** for the number of attacks and bonuses.

6. Sensor System Note: The Sunfire has all the standard robot features, plus the following:

A. Enhanced Radar: Can identify and simultaneously track up to 120 different targets. **Range:** 100 miles (160 km). **Note:** Includes an extensive Identify Friend and Foe (IFF) database. This system can identify a target and assign it priority based on known abilities and threat level. Provides bonuses to all combat robots, tanks and power armor within a one mile (1.6 km) radius of the Sunfire that are receiving the data transmission: +1 on initiative and +1 to strike. This bonus also applies to the Sunfire itself in hand to hand combat.

B. Communications and Data Relay Capabilities: Wide-band and directional radio communications system with built-in scrambler that transmits both audio and video from the cockpit, communications suite and battlefield video. Effective range of 500 miles (800 km); one third that range in the mountains, underground, and during storms. Includes the capability of sending and receiving scrambled/coded audio and video transmissions.

Audio pick-up and filtration system works both multi-directionally and as a shotgun mic. It can pick up sound as quiet as a whisper up to 400 feet away (122 m) and can sift through ambient sound for specific noises. Up to 100 hours of audio can be recorded and kept on file.

C. Tactical Cameras: Four cameras, two in the head and one in each gun, can record a total of 8,000 hours of footage into memory. Video footage can also be transmitted live to one or more receivers, or stored and sent at a later time. The pilot 'sees' via the cameras.

D. Built-in Language Translator: Programmed with the nine known languages of the Americas and can hold 12 additional languages. It can recognize and monitor up to three different voices and two different languages or dialects. Level of accuracy is 98.7%, with a three second delay when directed at one individual, but drops to 78% with a six second delay when translating three speakers simultaneously.

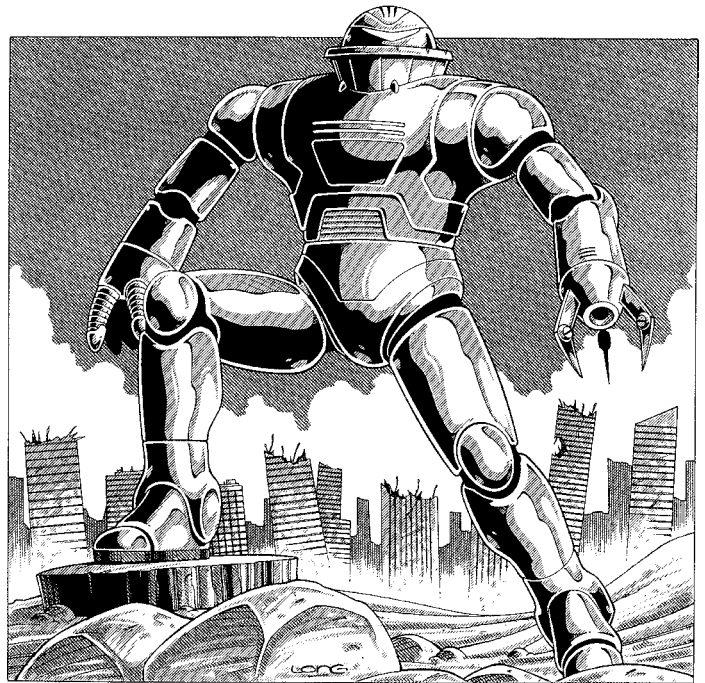

NG-V10 Super Labor Robot

The NG-V10 is a *giant robot vehicle* that looks like a giant version of the humanoid-shaped NG-W10 Heavy Labor Drone. It is designed for construction work and to aid humans working under hazardous conditions and otherwise deadly environments (bottom of a lake or sea, desert, toxic, etc.). Although originally intended for labor in mines and construction, the NG-V10 Super has become a favorite among explorers, adventurers and Headhunters, as well as Robot Pilots who enjoy mixing it up in hand to hand combat.

NG-V10 Super Labor Robot

Nicknames: Big Laborer and Super Laborer.

Model Type: NG-V10

Class: Ground Labor Robot Vehicle.

Crew: One pilot, with room for one passenger, although very cramped.

M.D.C. by Location:

* Hand (1, right) – 30

Laser-Claw Hand (1) – 60

Arms (2) – 90 each

Legs (2) – 185 each

* Head – 180

Reinforced Pilot Compartment – 100

** Main Body – 375

* A single asterisk indicates a small and difficult target to strike, requiring the attacker to make a *Called Shot*, but even then the attacker is -4 to strike.

Destroying the head destroys the targeting system, sensors and optics (no bonuses to strike, parry or dodge), leaving the pilot to rely on his own human senses.

** Depleting the M.D.C. of the main body shuts the robot down completely, making it useless.

Speed:

Running: 60 mph (96 km) maximum. Note that the act of running does NOT tire out its operator. Cruising speed is a more cautious 25 mph (40 km). Well suited for most terrains, including underwater, mining, climbing, and mountain terrains. Excellent for mining (digging) and construction operations.

Digging: 1D6x100 cubic yards/meters per hour through soft earth just digging a hole, 1D6x10 cubic yards/meters of tunneling through soft earth per hour with the intention of making a sustainable tunnel with the proper support and wall construction to prevent collapse. Half that amount digging through stone, concrete, or M.D.C. materials.

Leaping: 10 feet (3 m) high or across from a stationary position; 20 feet (6 m) high or 30 across (9 m) with a running start.

Water: Fair, able to walk along the bottom of lakes and seas at about half its normal speed. Maximum depth tolerance is 2,500 feet (762 m).

Flying: Not possible.

Statistical Data:

Height: 20 feet (6 m).

Width: 10 feet (3 m).

Length: 8 feet (2.4 m).

Weight: 18 tons.

Physical Strength: Equal to a Robotic P.S. 38.

Cargo: None.

Power System: Nuclear; average 10 years of life. Solid Oxide and electric battery models are also available.

Cost: 16 million credits nuclear, 12 million Solid Oxide and 10 million electric battery. Civilian versions armed only with the laser-claw hand sell for 2 million credits less than the combat variant.

Weapon Systems:

1. Laser-Claw Hand (1): The left hand is a powerful, three-fingered claw used for digging through and pulverizing rock in mining, construction and excavation operations. The same arm has a heavy laser for cutting through rock, metal, debris and M.D.C. materials.

Primary Purpose: Labor/Mining.

Secondary Purpose: Cutting and Welding.

Mega-Damage: Four settings: 1D6 M.D., 2D6 M.D., 4D6 M.D., 6D6 M.D.

Rate of Fire: Can only fire one blast at a time, and each counts as one melee action/attack regardless of power setting.

Range: 2,000 feet (610 m). Range can be extended to 4,000 feet (1,219 m) by adding a long barrel at a cost of 80,000 credits, but the claw hand becomes useless and the heaviest setting is 4D6 M.D. (the 6D6 M.D. setting is lost).

Payload: Effectively unlimited.

2. Hand to Hand Combat: Rather than use a weapon, the pilot can engage in Mega-Damage hand to hand combat. See *Heavy Ground Robot Training* on page 352 of **Rifts® Ultimate Edition** for the number of attacks and bonuses. Same as listed except as follows:

Restrained Punch – 1D4 M.D.

Full Strength Punch (right hand) – 2D6 M.D.

Power Punch, counts as two melee attacks – 4D6 M.D.

Claw Strike (left hand) – 3D6 M.D.

Crush, Pry or Tear (claw) – 3D6 M.D.

Dig – 2D6 M.D.

Power Dig – 4D6 M.D.

Kick – 3D8 M.D.

Leap Kick – 5D8 M.D.

Stomp – 1D4 M.D. but is only possible against targets eight feet (2.4 m) or smaller.

3. Sensor System Note: The NG-V10 Super Labor 'Bot has full optical systems, including laser targeting, telescopic, passive nightvision (light amplification), thermo-imaging, infrared, ultraviolet, and polarized filters to reduce glare.

4. Optional Weapon Systems: Rail Gun: The robot can be armed with a giant-sized NG-202 or TX-500, or other large rail gun. A separate power pack can be mounted onto the back of the robot or it can be tapped into the 'Bot's own nuclear power source. The rail gun can be stowed on a mounting on the hip or back, behind the right shoulder or carried in hand. Cost is limited to the expense of the rail gun plus 6,000 credits to hook it all up. Tapping into the robot's power is tricky work and costs 50,000 credits.

5. Optional Weapon Systems: Concealed Particle Beam or Plasma Rod: A particle beam or plasma weapon is concealed in one of the legs and powered by the robot's nuclear engine.

Primary Purpose: Assault.

Secondary Purpose: Defense.

Mega-Damage: Particle Beam 6D6+6 M.D., or Plasma 5D6 M.D.

Range: Particle Beam: 1,600 feet (488 m). Plasma: 2,000 feet (610 m).

Rate of Attack: Each blast counts as one melee attack/action.

Payload: Effectively unlimited.

Cost: Weapon system and integration into robot's power source: 200,000 credits.

NG-8000 Super Max

The Super Max is Northern Gun's response to the Triax X-1000 Ulti-Max power armor. The Super Max, however, is an actual giant robot, NOT a power armor suit. It is a new and unique design that came from the drawing boards of **Ryan Mahoney, Rob Byrne, Dylan Lundrigan, Gil Lee Ba and Ben Rodriguez**, built to have a relatively small profile like the Triax Ulti-Max. Its small size and slight build (for an NG robot) can only support light armor, but the Super Max is an innovative design with surprising speed, agility and firepower. The Northern Gun engineers had originally thought of the unit as an urban defense robot small enough to patrol city streets, parks, courtyards and even the halls and lobbies of some buildings. However, as their ideas developed, they found the Super Max was versatile enough for all arenas of combat and all environments. It is small and nimble enough to run, leap and climb stairs, scale walls and pillars, climb trees and cliff facings, take cover, dodge and roll. The hands are small and articulate enough to use weapons designed for Combat Cyborgs or handle and set explosive charges, operate most equipment and make repairs on other robots and vehicles. And should one or both of its delicate hands or arms be destroyed, the bulk of the Super Max's built-in weapon systems are in its upper torso and available to strike back with a vengeance.

For enhanced speed, leaping capabilities and jumping, the Super Max has an oversized robot jet pack in its back. Booster jets built into the shoulders, lower legs and feet provide control, balance and additional lift and mobility. The robot cannot fly, but

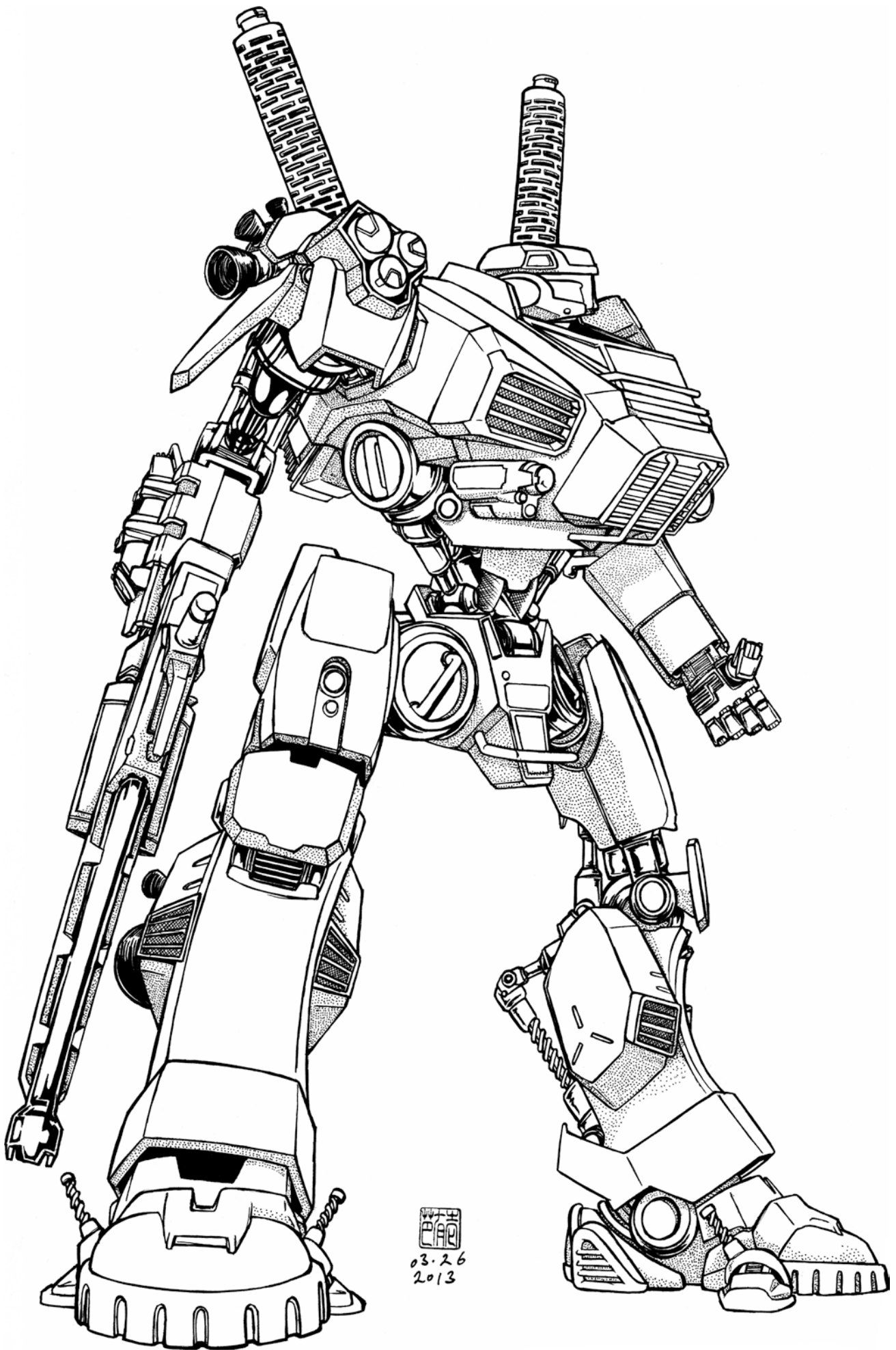

03.26
2013

it can jump up to 60 feet (18.3 m) high and 100 feet (30.5 m) across with booster assisted leaps, or jump down from elevations as tall as 1,000 feet (305 m) or roughly ninety stories. This gives the Super Max the ability to jump to the roof of a small building (or climb the building's facade), to run and leap from rooftop to rooftop and use the elevated position to target enemies on the street below or flyers as they pass overhead. Moving from rooftop to rooftop also enables the Super Max to avoid traffic, circumvent ground forces, take shortcuts to cut off a fleeing enemy and access alleys and back streets that might be too narrow for larger robots. Likewise, it can bound over giant robots, tanks, debris, walls and other obstructions, and move quickly across the battlefield. This mobility and speed enables the Super Max to use the terrain to its tactical advantage. The legs and feet are reinforced so that the robot can survive hard landings and remain intact. One of the commercials that Northern Gun runs shows a Super Max jumping onto the roof of a pre-Rifts building in Detroit, racing across to the other side and making another leap into a handful of Brodkil on the street below. Even as the Super Max drops down upon the startled Brodkil, it unleashes a salvo of grenades while blasting away with its handheld weapon. Half of the subdemons are dead before the Super Max hits the ground. The rest are finished off 30 seconds later. The attack is quick and lethal. Best of all, the video is not staged. It is actual, real-life footage shot by one of NG's mercenary groups that helps field test robots before they are put on the market. This video is a sensation and has helped to catapult the Super Max to the top of the charts as Northern Gun's Number One selling combat robot among its 109 P.A. Spring releases. Demand is so high that the company can't produce them fast enough.

To compete with Triax's Ulti-Max and increasing competition from the Manistique Imperium, Titan Robotics, Bandito Arms (see **Rifts® Black Market Sourcebook**), and others, Northern Gun is marketing more and more of their new line of robots with what they are calling 'upward mobility.' Robots built for diversity, multiple operational parameters (e.g. combat and exploration, combat and construction, etc.) or easily modified to meet a wide variety of missions.

Model Type: NG-8000 Super Max

Class: Infantry Assault Robot.

Crew: One, the pilot.

M.D.C. by location:

- * Head Sensor Array (NG-CNC99 Command and Control Pod) – 75
- * Head Spotlights (2, forehead) – 5 each
- * Hip Lights (2, one per leg) – 3 each
- Upper Arms (2) – 90 each
- Forearms (2) – 100 each
- * Hands (2) – 25 each
- Legs (2) – 150 each
- * Feet (2) – 100 each
- * Main Booster Jets (2, back) – 115 each
- * Robot Rifle (1, varies; handheld) – 90
- * Ammo Drum for Rail Gun (1, upper back when applicable) – 50
- * NG-G88 Beehive Grenade Towers (2) – 70 each
- * NG-M99 Mini-Missile Pod (left shoulder) – 75
- * NG-C44 Short-Range Missile Pod (right shoulder) – 60
- * NG-48 Forearm Weapons (2) – 30 each
- ** Hardpoints (6, two per leg, two on the chest) – 5 each

** NG-41 Chest Mini-Missile Tube (1 per side, small) – 12 each

** Combat Cameras (3, head and below the Chest Tube) – 6 each

* Reinforced Pilot Compartment – 70

*** Main Body – 350

* A single asterisk indicates a small and/or difficult target to strike, requiring the attacker to make a "Called Shot," but even then he is -3 to strike.

Destroying one of the main thruster jets reduces leaping height and distance by half and maximum running speed is 75 mph (120 km). Destroy both jets and the enhanced leaping capability is completely eliminated; reduce bonus to dodge by half.

Destroying the head, which is the control and command pod, knocks out all long-range radio communications, radar and sensor systems; -2 on all combat bonuses! The pilot must rely on the cameras built into the chest to see.

** Two asterisks indicates an obstructed view and a difficult target to strike, requiring the attacker to make a "Called Shot," but even then he is -3 to strike (-4 when the robot is moving) and may only be visible from certain angles; even more difficult (-1) when the robot is moving.

*** Depleting the M.D.C. of the main body shuts the vehicle down completely, making it useless.

Speed:

Running: 60 mph (96 km) maximum. Running and jet booster assisted leaps to cover ground more rapidly: 90 mph (144 km). Can leap and climb the side of a building at a stunning speed of 40 mph (64 km).

Leaping: 10 feet (3 m) high and 20 feet (6.1 m) across without the assistance of the boosters. With the leap thruster system operational, the Super Max can leap up to 60 feet (18.3 m) high and 100 feet (30.5 m) across. It can also drop from high elevations as tall as 1,000 feet (305 m) or roughly nine stories with the thrusters slowing descent to land on its feet like a cat and charge off into combat (or be firing at the enemy the entire descent).

Water: The Super Max can use its leap thruster system to lurch through water in a herky-jerky swimming motion at a speed of 25 mph (40 km) or it can walk along the bottom of lakes and seas at the same speed. Maximum depth tolerance is 2,000 feet (610 m).

Flying: Actual flight is not possible; see *Leaping*.

Statistical Data:

Height: 17 feet (5.2 m) from head to toe, but the Beehive Grenade Launchers extends to 21 feet (6.4 m).

Width: 11 feet, 6 inches (3.5 m).

Length: 9 feet, 6 inches (2.9 m).

Weight: 6.5 tons.

Physical Strength: Robotic P.S. 30.

Cargo: There is a small area for the pilot to store his personal belongings. There is enough room for light body armor, a rifle, pistol a canteen, food rations (4 week supply) and a first aid kit. There is a small, two gallon (7.6 liter) water cooler built in.

Power System: Nuclear power supply; 20 year life.

Cost: 21 million credits, but demand is so high NG can't keep the robot in stock. Poor availability at list price. Sold out in showrooms everywhere! Fair availability at 50% higher and good availability at double the list price on secondary markets (Black Market, independent robot dealers, mercenary companies, etc.). The price includes all built-in weapon systems and an NG-1001

Robot Rifle all with one complete load of ammo. Northern Gun hopes to ramp up production within a year.

Future Market Note: Models of the Super Max deploying a Solid Oxide Fuel Cell and Electric battery power supplies are on the drawing board. They should be released within a year with the following 'list price': Solid Oxide Fuel Cell: 17 million credits. Electric battery: 14 million credits; but are almost certain to sell out quickly and sell on the secondary market for 50% more to double. NG is even thinking of increasing the original list price on all models by 30%. Obviously, the market can bear the price increase.

Weapon Systems:

1. Robot Handheld Rifle (1): Northern Gun's concept of upward mobility means giving its robots options and diversity. In this case, the Super Max can carry and use large handheld weapons.

(Option A) NG-1001 Robot Rail Gun Rifle: The NG-1001 is sold separately (see **Rifts@ Merc Ops**, page 95) to give customers the option to use the rifle with other robots, but is standard with the purchase of a Super Max. The Super Max was designed with the NG-1001 in mind. The under-mounted, detachable drum can be swapped in battle quickly. The rifle has its own independent power supply, which is a plus in that there are no bulky power cables which are often vulnerable. Additional ammo drums are often stored on one of the available weapon hardpoints.

Primary Purpose: Assault.

Range: 4,000 feet (1,219 m).

Mega-Damage: A burst is 20 rounds and inflicts 1D6x10 M.D., one round does 1D4 M.D. As usual, anti-monster rounds (silver, etc.) can be fired from the rail gun, but at half the range.

Rate of Fire: Each burst counts as one melee attack/action.

Payload: 920 rounds or 46 bursts per detachable drum magazine. Additional drums can be carried on one of the leg's weapon hardpoints. One of the unique features that the Super Max has is being able to change the ammo drum in the field. The ammo drum on the weapon can be automatically ejected when depleted. All the pilot has to do is change the clip as if he were changing a clip on a normal weapon. The automated systems then take over and cycle the ammo into the weapon. In all it takes 15 seconds (one melee) to change the ammo drum.

(Option B) NG-P8011 Robot Particle Beam Rifle: The NG-P8011 is an oversized rifle designed specifically with the Super Max in mind. The weapon can, theoretically, be used by Combat Cyborgs and heavy power armor as an oversized, *two-handed weapon*, but its size, weight and awkwardness when used by smaller, lighter units inflicts a -2 to strike penalty for them.

This is the newest particle beam weapon released by NG in years. The company had moved away from P-beam weapons due to the level of power they drain, short range and stability concerns. In fact, when the NG-P8011 rifle (90 M.D.C.) is damaged (M.D.C. is reduced to 30 or less) one of the following takes place (roll percentile dice): **01-50%** The rifle begins to sizzle, smoke and stops working completely. **51-75%** The rifle smokes and bursts into flames (1D6 M.D. to the robot's hand). It burns until the rifle is a glob of slag. **76-00%** It explodes, doing 1D6x10 M.D. to the hand and everything within a 4 foot (1.2 m) radius. **Note:** Uses a standard E-Clip.

A backpack-style bag (30 S.D.C.) or ammo box (15 M.D.C.) containing as many as eight extra E-Clips are often stored on one of the available weapon hardpoints on the chest or leg.

Primary Purpose: Assault.

Range: 1,400 feet (427 m).

Mega-Damage: 1D4x10 M.D. per blast.

Rate of Fire: Single shot only. Each blast counts as one melee attack.

Payload: 8 shots per standard E-Clip. NG NEVER authorizes tying this weapon into the robot's power supply, because if the gun burns out or explodes it damages the energy supply of the 'Bot, fries the sensor system and does 2D6x10 M.D. to the main body.

(Option C) Cyborg Rail Guns and Heavy Weapons: The hands of the Super Max are small and delicate enough to be able to operate most medium and heavy cyborg weapons and all handheld weapons designed specifically for robots (Triax has many of these). Such guns can be used as an alternative or in addition to the NG-1001. Northern Gun recommends the NG-404 Heavy Rail Gun or the NG-ML6 Mini-Missile Cannon (both introduced in **Rifts Merc Ops**, page 94).

(Option D) Melee Weapons: The Super Max is able to wield most large melee weapons, such as large Vibro-Swords. Of course, in a pinch, tree limbs, pipe, and other weapons can be used (including large TW and other magic weapons for adventurers operating outside of Ishpeming and CS territory).

2. Forearm Weapons: Various options. Each forearm can have one modular weapon system. Standard issue is the mini-missile tube launcher for its range and power, but a variety of energy weapons are also available. **Note:** The Super Max may have the same forearm weapon on each arm (standard manufacture is two NG-M48 mini-missile launchers on each arm) or a different one on each arm. Costs 15,000 credits to change each standard factory issue launcher plus the cost of the alternative forearm weapon and the necessary ammo.

(Option A) NG-M48 Forearm Mini-Missile Launcher: Forearm weapons and mini-missile tube launchers are seen in many of Northern Gun's robots. The only drawback is the arm holding the NG-1001. The rail gun must be out of the hand before a mini-missile is launched to fire without penalty (-1 to strike). The jet wash of the missiles has also been known to damage the targeting system of the rifle (01-50% chance), which is another reason to stow the rifle or switch hands before firing mini-missiles.

Primary Purpose: Assault and Anti-Armor.

Secondary Purpose: Anti-Missile and Defense.

Range: One mile (1.6 km).

Mega-Damage: Varies with the missile type used. Usually Plasma (1D6x10 M.D.) or A.P./Heat rounds (1D4x10+5 M.D.), but any type can be used.

Rate of Fire: One at a time or in volleys of two per arm.

Payload: 8 total; four per arm (two per tube launcher).

Cost (of Launcher): 50,000 credits each, plus 6,000 credits per missile.

(Option B) Forearm Laser: A low-profile forearm weapon. Point and shoot.

Primary Purpose: Assault and Anti-Personnel.

Secondary Purpose: Defense.

Range: 2,000 feet (610 m).

Mega-Damage: 3D6 M.D. per blast.

Rate of Fire: Each single.

Payload: Effectively unlimited.

Cost: 40,000 credits each.

(Option C) Forearm Plasma Ejector: A low-profile forearm weapon. Point and shoot.

Primary Purpose: Assault and Anti-Personnel.

Secondary Purpose: Defense.

Range: 1,200 feet (366 m).

Mega-Damage: 4D6 M.D. per blast.

Rate of Fire: Each single.

Payload: Effectively unlimited.

Cost: 52,000 credits each.

(Option D) Forearm Ion Blaster: The blaster is a double-barreled, short-range ion blaster. Point and shoot.

Primary Purpose: Anti-Personnel.

Secondary Purpose: Defense.

Range: 1,200 feet (366 m).

Mega-Damage: 3D6 M.D. per single blast, 6D6 M.D. per simultaneous dual blast at the same target.

Rate of Fire: Each single or double blast counts as one melee attack.

Payload: Effectively unlimited.

Cost: 65,000 credits each.

(Option E) Forearm Particle Beam Blaster: A low-profile forearm weapon. Point and shoot.

Primary Purpose: Assault and Anti-Personnel.

Secondary Purpose: Defense.

Range: 1,000 feet (305 m).

Mega-Damage: 6D6+6 M.D. per blast.

Rate of Fire: Each single blast counts as one melee attack.

Payload: 8 blasts per E-Clip. NEVER tied directly to power supply.

Cost: 70,000 credits each.

3. NG-C44 Shoulder-Mounted Short-Range Missile Pod (1, right shoulder): When heavier engagements are expected, the Super Max has three short-range missiles it can fire from its right shoulder. Standard issue, no substitutes by NG. However, it could easily be swapped out with the NG-M99 Shoulder Mini-Missile Launcher by a capable Operator.

Primary Purpose: Assault.

Secondary Purpose: Anti-Aircraft.

Range: Five miles (8 km).

Mega-Damage: Varies with the missile type used. Standard load is armor piercing (2D6x10 M.D. to a 5 foot/1.5 m radius) or plasma (2D6x10 M.D. to a 15 foot/4.6 m blast radius).

Rate of Fire: One at a time or in volleys of two per launcher.

Payload: 3 short-range missiles.

Cost: 75,000 credits for the launcher. Short-range missiles generally cost 2,000-4,500 credits each, depending on type. See page 256 of **Rifts® Ultimate Edition** for prices.

4. NG-M99 Shoulder Mini-Missile Launcher (1, left shoulder): The designers of the Super Max wanted to match or exceed the Ulti-Max's firepower. However, instead of several mini-missile launchers, they combined mini-missiles with the new Beehive Grenade launchers. This launcher is part of the Super Max's multiple-missile weapon system. It is standard issue, no substitution by NG. However, it can easily be swapped out for the NG-C44 Shoulder-Mounted Short-Range Missile Launcher by a capable Operator.

Primary Purpose: Anti-Aircraft, Anti-Armor, and Assault.

Secondary Purpose: Anti-Missiles and Defense.

Mega-Damage: Varies with the missile type used. Usually Plasma (1D6x10 M.D.) or A.P./Heat rounds (1D4x10+5 M.D.), but any type can be used.

Rate of Fire: One at a time or in volleys of 2, 4 or 6.

Range: One mile (1.6 km).

Payload: 12 total.

Cost: 65,000 credits for the launcher. Mini-missiles generally cost 1,200-2,500 credits each depending on type. See page 257 of **Rifts® Ultimate Edition** for prices.

5. NG-G88 Beehive Grenade Launchers (2): This is a new and somewhat experimental design that has functioned well in field tests. The sheer volume of mini-missiles that could be launched by the Ulti-Max was impressive, and the designers of the Super Max wanted similar or superior capabilities for their robot. Rather than deck it out in mini-missiles, they created the Beehive Grenade Launcher. Range is short, especially compared to mini-missiles, but the barrage that is possible against ground troops, ground vehicles, robots, monsters and fortifications is devastating. It is important to note that only half of the slits in the stacks hold and fire grenades, the other half are vents. The launch towers can rotate 360 degrees to fire in the desired direction, but rim the launch tower, making it possible for the pilot or gunner to fire front, back or to the sides at any time. Each slot contains one grenade. This launcher is part of the Super Max's multiple-missile/explosives weapon system. It is standard issue, no substitutions.

Primary Purpose: Anti-Personnel and Anti-Monster.

Secondary Purpose: Anti-Fortifications and Assault.

Range: 1,200 feet (366 m).

Mega-Damage: Varies with grenade type. A typical payload is 12 smoke (see the Grizzly for description), 12 HEX grenades (see the Grizzly), 30 fragmentation grenades (2D6 M.D. to a blast radius of 20 feet/6.1 m), and 30 explosive grenades (4D6 M.D. to a six foot/1.8 m radius).

Rate of Fire: One at a time or in volleys of 2, 4, 6 or 8. A volley, regardless of the number of grenades fired, counts as one melee attack.

Payload: 88 total; 44 grenades per beehive tower.

6. Hand to Hand Combat: Rather than use a weapon, the pilot can engage in Mega-Damage hand to hand combat as per *Robotic P.S. 30*. See *Light Ground Robot Training* on page 353 of **Rifts® Ultimate Edition** for number of attack and bonuses.

Restrained Punch – 1D4 M.D.

Full Strength Punch – 2D4 M.D.

Power Punch – 2D6 M.D.; counts as two melee attacks.

Stomp & Tear Attacks – 1D4 M.D.

Leap Kick – 2D8 M.D.; counts as two melee attacks.

Jet Boosted Leap Kick (special) – 3D6+2 M.D. and is only possible with a jet assisted leap; counts as two melee attacks.

7. Sensor Systems & Features of Note: The Super Max has all standard robot sensor and features plus those described below.

A. NG-CNC99 Command and Control Pod/Head: The NG-CNC99 is a large sensor, communications, targeting and computer array built into the head of the Super Max to function as a mobile relay station and mini-mobile command unit. The pilot sits in the chest and relies on sensors, instruments and live video feed to 'see' and target the enemy.

Enhanced Radar: Can identify and simultaneously track up to 120 different targets. **Range**: 100 miles (160 km). **Note**: Includes an extensive Identify Friend and Foe (IFF) database.

This system can identify a target and assign it priority based on known abilities and threat level. Provides bonuses to all combat robots, tanks and power armor within a one mile (1.6 km) radius of the Super Max that are receiving the data transmission: +1 on initiative and +1 to strike. This bonus also applies to the Super Max itself.

Enhanced Sonar: Can identify and simultaneously track up to 96 different targets for underwater operation. **Range:** 50 miles (80 km). Same IFF and relay capabilities as radar.

Communications and Data Relay Capabilities: Wideband and directional radio communications system with built-in scrambler that transmits both audio and video from the cockpit, communications suite and battlefield video. Effective range of 500 miles (800 km); one third that range in the mountains, underground, and during storms. Includes the capability of sending and receiving scrambled/coded audio and video transmissions.

Audio pick-up and filtration system works both multi-directionally and as a shotgun mic. It can pick up sound as quiet as a whisper up to 400 feet away (122 m) and can sift through ambient sound for specific noises. Up to 100 hours of audio can be recorded and kept on file.

Thermal-Imager: A special optical heat sensor that allows the infrared radiation of warm objects to be converted into a visible image. Enables the pilot to see in the dark, in shadows, and through smoke. **Range:** 2,000 feet (610 m).

Infrared and Ultraviolet Optics: This optical system projects a beam of infrared light that is invisible to the normal eye. The infrared beam enables the pilot to see in the dark and to see other infrared beams. The ultraviolet system enables the pilot to see into the ultraviolet spectrum of light and is mostly used to detect the light beams of ultraviolet detection systems. **Note:** The infrared light beam can be seen by anybody who also has infrared optics, and the beam can be traced back to its source. Smoke impairs the infrared beam, making it impossible to see.

Nightvision Optics: Passive light amplification that allows the pilot to see in the dark as long as there is at least some ambient light. 2,000 foot (610 m) range, but is completely useless in total darkness.

Note: If the head/sensor array is destroyed, all of the above features are lost.

B. Built-in Language Translator: Programmed with the nine known languages of the Americas and can hold 12 additional languages. It can recognize and monitor up to three different voices and two different languages or dialects at once. Level of accuracy is 98.7% with a three second delay when directed at one individual, but drops to 78% with a six second delay when translating three speakers simultaneously.

C. Tactical Cameras (3): One in the head and one on each side of the chest. Three digital video cameras send live feeds directly into the cockpit and HUD of the pilot's helmet. Live feed can be relayed throughout the robot and displayed on monitors, HUD and screens not only to the pilot inside the Super Max but to robots in the same company, mobile command, and any designated recipient within range (500 mile/800 km transmission range). Each camera has a 4,000 foot (1,219 m) range with telescopic lenses as well as macro-lenses for seeing up-close, x10 magnification. Can store up to 10,000 hours of

video footage before requiring transfer to some other medium. Includes image and video transmission capabilities.

D. Weapon Hardpoints (6): There are six hardpoints where extra gear and ammo drums can be attached to the Super Max. There are two on each leg and one on each side of the chest.

Optional Add-On: NG-A64 Modular Armor Components: That's right! Additional armor can be clamped on to cover key locations on the robot for extra protection. The M.D.C. of this additional armor, if worn, comes off first. When all M.D.C. is depleted, the section of armor drops away. **Note:** The bulk and less aerodynamic design reduces speed by 25% and reducing the leaping height and distance by half, including dropping down from heights, and inflicts the penalties of -1 on initiative and -1 to dodge.

Extra M.D.C. by Location:

Head Covering (helmet-like) – 40

Upper Arms (2) – 50 each

Forearms (2) – 50 each

Legs (2) – 60 each

Cost: 500,000 credits.

NG-V58 Thundercaster

The Thundercaster is the little robot that packs a big wallop. After so many big 'Bots in the NG product line, the team of **Jason M. Volinsky, David Thompson and Randy P. Belanger** wanted to design a small, heavily armored, heavily armed robot. They were inspired by the wolverine, a small but fierce animal known to stand its ground against predators many times larger than itself to defend its burrow, and win. They even wanted to name the robot after the animal, but the NG marketing team branded it the Thundercaster, for reasons that will become apparent.

The Thundercaster has only been available, even to insiders, for the last few months (Summer 109 P.A.). It is a robot built with mercenaries and independent warriors in mind, and is designed to offer versatility and survivability on the battlefield.

The primary weapon system of the Thundercaster is a sort of all-purpose artillery cannon – a large and intimidating weapon that 'casts the thunder' – every time it fires it makes a considerable 'boom' sound. (See the weapon description below for complete details.) Its secondary weapon is also thunderous: an NG-404 gatling-style rail gun built into the right arm. There is one internal ammo drum installed within the arm itself, but a larger ammo drum can be hooked to the back where the shoulder-blade would be on a human, and fed by a belt that loops from the drum under the shoulder and into the big rail gun. This is less obtrusive than one might imagine, because the right arm does not bend at the elbow. It bends just above what would be the biceps of a human. This limits the range of movement for the lower armor and hand, but the hand can still be used for lifting and carrying, and the gun arm can bend and shoot in a 90 degree up and down arc. The big shoulders actually contain extra artillery rounds for the Thunder Cannon. The left arm has a double-barreled laser mounted on the forearm.

The head of the Thundercaster is a sensor and communications array, while the pilot and gunner sit in the chest. There is a plexiglass window should the pilot want to see without instruments, otherwise the window is shielded by M.D.C. metal plates that slide into place with the press of a button. In the belly is one

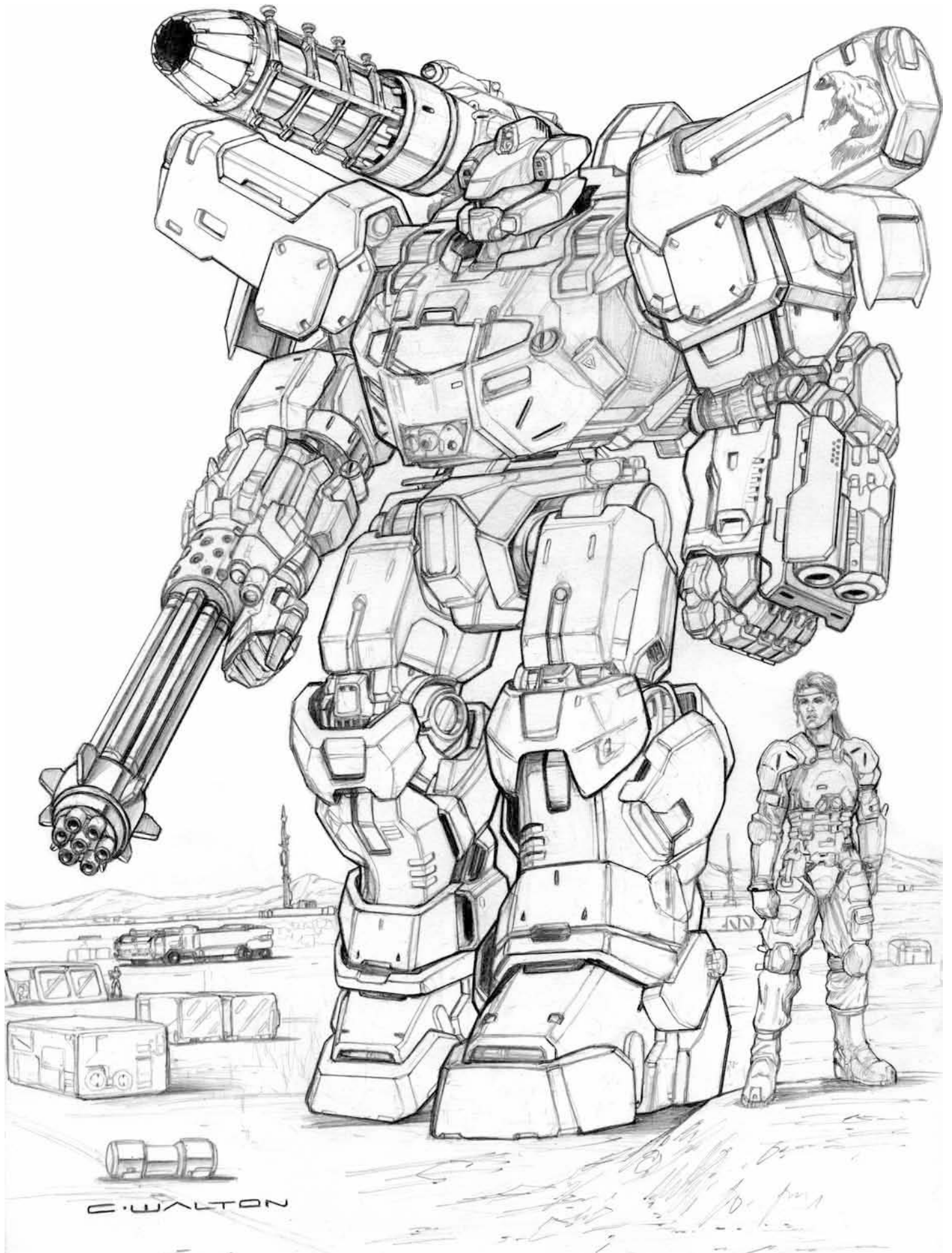

of the five cameras that the pilot uses to drive the robot. There are others in the sensor head and each weapon platform. To help the Thundercaster take a beating from larger combat robots and monsters, it is heavily armored, yet still retains decent speed.

This tough, small combat robot is NG's most recent release. The unusual Thunder Cannon and other design elements all have people talking, and the model is selling very well.

Model Type: NG-V58 Thundercaster.

Nicknames: Walking Thunder, Michigan Wolverine and Little Wolverine.

Class: Infantry Assault Robot.

Crew: One pilot and one gunner (or a passenger). The pilot drives and fires the arm weapons and the gunner or passenger usually fires the Thunder Cannon.

M.D.C. by Location:

* Sensor Head – 75

Thunder Cannon (1, shoulder) – 135

* Shoulder Ammo Compartments (2) – 80 each

* Camera/Spotlight (1, cannon) – 5 each

Rail Gun Arm (1, right arm) – 125

Left Arm (1) – 125

* Laser Blaster (left forearm) – 50

* Hands (2) – 35 each

* Ammo Hopper (1, back) – 50

Upper Legs (2) – 170 each

Lower Legs & Feet (2) – 225 each

* Upper Leg Headlights (2, small) – 5 each

* Belly Camera (1) – 8

* Reinforced Pilot Compartment – 100

** Plexiglass Window (1, large) – 35

** Plexiglas Windows (2, small) – 15 each

** Sliding M.D.C. Window Shield (1, large) – 75

** Sliding M.D.C. Window Shields (2, small) – 30 each

*** Main Body – 400

* A single asterisk indicates a small and difficult target to strike, requiring the attacker to make a 'Called Shot,' but even then the attacker is -4 to strike.

** The Thundercaster has a plexiglass viewport/window in the chest. The large M.D.C. plexiglass window has 35 M.D.C. and the small ones have 15 M.D.C. each. However, they also have metal alloy plates that slide into place in combat situations with the press of a button or voice command from the pilot. The metal plating provides the large window with 75 M.D.C. and each small window with an additional 30 M.D.C.; the pilot drives via video images from various cameras and via instruments. An attacker needs to make a *Called Shot* to target a specific window, but suffers a penalty of -3 to strike. Destroying the M.D.C. of the window plexiglass and M.D.C. window shielding makes the Reinforced Pilot Compartment vulnerable to attack. When it is depleted to zero, the pilot and crew are vulnerable inside.

*** Depleting the M.D.C. of the main body shuts the vehicle down completely, making it useless.

Speed:

Running: 55 mph (88 km) maximum.

Leaping: 7 feet (2.1 m) high and 14 feet (4.3 m) across.

Water: Cannot swim, but can walk along the bottom of lakes and seas at a speed of 20 mph (32 km). Maximum depth tolerance is 2,000 feet (610 m).

Flying: Not possible.

Statistical Data:

Height: 17 feet (5.2 m) from head to toe, but the Thunder Cannon can point higher.

Width: 14 feet (4.3 m).

Length: 8 feet, 6 inches (2.6 m).

Weight: 10.5 tons.

Physical Strength: Robotic P.S. 35.

Cargo: There is a small area for the pilot to store his personal belongings and enough room for light body armor, a rifle, a pistol, two canteens, food rations (2 week supply) and a first aid kit. There is a small, two gallon (7.6 liter) water cooler built in.

Power System: Nuclear; average energy life is 20 years. Solid Oxide Fuel Cell and electric battery versions are also available.

Cost: Nuclear: 23 million credits. Solid Oxide Fuel Cell: 17 million credits. Electric battery: 14 million credits. The price in all categories includes a full ammo payload for all weapon systems. Demand is strong and the robot has been selling for 20-30% above list price at some stores. Fair availability.

Weapon Systems:

1. NG-C58 Variable Projectile Cannon (1): The primary weapon system of the Thundercaster is a sort of all-purpose artillery cannon – a large and intimidating weapon that 'casts the thunder.' Though it is officially known as the *NG-C58 Variable Projectile Cannon*, it has been dubbed the **Thunder Cannon** by NG marketing. It is a large, air-pressure powered tube that can launch a wide range of ammunition and objects. One might think of it as a giant 'potato gun,' as the VPC can fire artillery shells designed for it, but also large rocks, bricks, bowling balls, cinder blocks, chunks of concrete, pieces of metal, fence posts, tree branches and logs (but no larger than 4 feet/1.2 m long or bigger than two feet/0.6 m in diameter). Just about anything with the minimum diameter of a man's fist or softball placed inside the cannon can be fired from it. The idea is that even in the wilderness, far from civilization, the Thunder Cannon can find ammunition. Moreover, when facing supernatural or magical creatures that may be vulnerable to wood, rock, iron, silver, salt, bone, etc., such unconventional materials can be placed inside the cannon and fired at the monster. These projectiles are launched with great velocity and inflict considerable damage.

The Thunder Cannon can be used as a weapon, a distraction or as a tool if the pilot is clever enough. The gun works by using a small laser to scan the projectile placed inside the barrel before it is fired. The barrel mechanism then contracts or expands to fit around whatever is going to be launched, and a computer adjusts the burst of high-pressure air based on its size and estimated weight. Explosive artillery shells come standard with the Thundercaster, but the C58 VPC's versatility means 'improvised' ammo is never hard to find. Heck, the Thundercaster can chop up young and medium-sized trees and large tree branches with its hands or lasers to create ready to use ammunition, as well as pull up rocks and debris.

It is the loading that is tricky. For the artillery shells, there is a sort of 'hopper' into which the round shells (and objects of similar size and shape) are placed. The ammo hopper can hold as many as eight shells, each one cycled into the firing chamber a moment after the previous one has been fired. Improvised ammo, however, requires a single projectile to be

hand-loaded into the cannon and fired before another projectile can be loaded into the weapon. In this regard it is rather like loading cannons of old, except that almost any object can be dropped into the front of the barrel or via a hatch in the back of the cannon. It typically takes the equivalent of two melee actions (5-6 seconds) for a prepared loader or loading crew (2-4 people), with ammo handy, to load the Thunder Cannon with a new projectile to fire.

Of course, due to the size of the Thundercaster combat robot, the weight of the improvised ammo, and the height of the cannon mounted on the robot's shoulder, another robot, teammate in flying (or large) power armor, a cyborg or other strong 'loader' (needs Robot or Supernatural Strength), is needed to physically place unconventional ammo into the cannon. The cannon can be loaded via a hatch in the back, or by dropping the projectile into the mouth of the big gun. If the loader cannot reach the cannon from the ground (he is not tall enough or cannot hover up to it), the Thundercaster may have to get down on its hands and knees. The robot's designers realized this and made certain the robot has legs and arms that enable it to do so quickly and easily (one melee action to get down, one melee action to stand back up). The Thundercaster can fire the cannon from a standing, kneeling, crouched or down on all fours position. This is also why the extra artillery shells are mounted in housings on the shoulders. When kneeling or down on all fours, the shells are easy to reach and easy to place into the hopper or directly into the cannon.

The Thunder Cannon has a 180 degree up and down arc of fire and a 45 degree side to side sweep. A spotlight and a laser distancer are built into the top of the cannon. However, since most improvised ammunition is not aerodynamic, it has minimal or no bonuses to strike.

While some critics insist the weapon is idiotic, adventurers who have field-tested this brand new release are impressed with it, especially for travel and time spent in remote regions. Reid's Rangers, the famous vampire hunters, have placed an order for two dozen Thundercasters.

NG-C58 Variable Projectile Cannon Stats: The big cannon over the right shoulder.

Primary Purpose: Anti-Fortification, Anti-Armor and Assault.

Secondary Purpose: Anti-Monster and Defense.

Range & Penalties: Varies with the type of projectile.

- Artillery shells designed for it: 1,400 feet (427 m). Penalty: Reduce the usual bonus to strike by half.
- Reasonably aerodynamic objects: 1,000 feet (305 m) when firing an object like a fence post or a smooth bowling ball. Penalty: Reduce the usual bonus to strike by half.
- Objects that are not aerodynamic: 700 feet (213 m) when firing an object like a brick or cinder block, crooked tree branch, log with bark still on it, a jagged piece of scrap, a large sword, a boulder and so on. Penalty: No bonuses to strike are applicable. NONE! Outcome is determined by the unmodified roll of a D20.

Weight Limit: The object being fired cannot weigh more than 300 pounds (135 kg).

Mega-Damage: Varies. S.D.C. items do S.D.C./Hit Point damage and M.D.C. items inflict Mega-Damage.

- Explosive shell designed for it: 1D6x10 M.D. to a 10 foot (3 m) blast radius.

- S.D.C. materials inflict damage typical for that object +4D6 S.D.C. damage (+30 S.D.C. if it weighs 150 pounds/67.5 kg or more).
- Mega-Damage materials inflicts damage typical for that object plus 2D6 M.D. (+10 M.D. if it weighs 150 pounds/67.5 kg or more).

Note: Explosive devices such as hand grenades, sticks of dynamite, and most missiles and explosives do NOT explode upon impact. They have to be activated or triggered in some way. Placing explosives into the Thunder Cannon, even with a time delay, is ill-advised. Pulling the pin on a hand grenade and dropping it into the cannon is only going to see the grenade explode before it can be launched, and damage or destroy the big gun. Likewise, munitions designed to explode on impact have a 01-33% chance of exploding when hit with the air burst that fires it from the cannon, causing it to explode while still inside the cannon (this does not include the artillery shells designed for the weapon, of course).

Rate of Fire: One shell or projectile at a time. Each shot counts as one melee attack.

Payload: 24 total. Eight shells can be placed in the 'hopper' and fed into the cannon by an auto-loader. Eight more are stored in each shoulder dispenser (16 total). As many as eight artillery shells, or objects of similar size and shape, can be placed in the hopper and fired in succession. All other types of 'improvised' ammo must be loaded by hand, either using the gun's breech or by simply dropping it down the muzzle of the barrel. Takes two melee actions/attacks to load the weapon and scan the projectile before firing.

2. **NG-R58 Rail Gun:** An NG-R58 multi-barrel rail gun is, in effect, the Thundercaster's right arm. It is attached to an adjustable joint high up on the arm that enables the weapon to point left and right, up and down. The gun has a camera with telescopic lens (6,000 feet/1,828 m) where a sight would normally be located, letting the pilot see what he is shooting at.

Primary Purpose: Anti-Armor.

Secondary Purpose: Assault.

Range: 4,000 feet (1,219 m).

Mega-Damage: 1D4 M.D. for a single round. A burst of 40 rounds inflicts 1D4x10 M.D.

Rate of Fire: Each single shot or burst counts as one melee attack.

Payload: 50 bursts before requiring a reload. 400 rounds are stored in the arm itself for 10 bursts. An ammo drum attached to the back with a belt feed into the rail gun contains 1,600 rounds (40 bursts). A second ammo drum is mounted on the back with another 1,600 rounds (40 burst), but the old drum needs to be removed and the full drum reloaded by hand (weighs 400 lbs/180 kg). This takes a skilled crew 1D4+2 minutes or an inexperienced crew 2D4+4 minutes.

3. **NG-L258 Double-Barreled Laser:** A twin-barrel laser weapon is built into the robot's left forearm. It can fire single beams for picking off enemy infantrymen and cutting, or dual beams for greater damage.

Primary Purpose: Anti-Personnel and Assault.

Secondary Purpose: Defense.

Range: 2,000 feet (610 m).

Mega-Damage: 3D6 M.D. per blast or 6D6 M.D. for a dual blast.

Rate of Fire: Each blast or dual blast counts as one melee attack.

Payload: Effectively unlimited.

4. Hand to Hand Combat: Rather than use a weapon, the pilot can engage in Mega-Damage hand to hand combat as per Robotic P.S. 35. See *Light Ground Robot Training* on page 353 of **Rifts® Ultimate Edition** for the number of attacks and bonuses.

5. Sensor Systems of Note: The Thundercaster has all the standard robot features, plus the following. The head of the robot is a sensor and communications array that also includes a camera.

A. Enhanced Radar: Can identify and simultaneously track up to 90 different targets. **Range:** 100 miles (160 km). **Note:** Includes an extensive Identify Friend and Foe (IFF) database. This system can identify a target, and assign it priority based on known abilities and threat level. Provides a bonus of +1 on initiative and +1 to strike with the rail gun and laser (does not include the Thunder Cannon).

B. Communications and Data Relay Capabilities: Wide-band and directional radio communications system with built-in scrambler that transmits both audio and video from the cockpit, communications suite and battlefield video. Effective range of 500 miles (800 km); one third that range in the mountains, underground, and during storms. Includes the capability of sending and receiving scrambled/coded audio and video transmissions.

Audio pick-up and filtration system works both multi-directionally and as a shotgun mic. It can pick up sound as quiet as a whisper up to 400 feet away (122 m) and can sift through ambient sound for specific noises. Up to 100 hours of audio can be recorded and kept on file.

C. Tactical Cameras (5): The robot has one camera in the sensor head, one on each arm, one on the Thunder Cannon and one in the belly. Can record a total of 8,000 hours of footage into memory. Video footage can also be transmitted live to one or more receivers, or stored and sent at a later time. Images are automatically transmitted to the pilot and gunner inside the robot to monitors and HUDs; the pilot sees and fights via the cameras. If helpful, the images and data can be sent to the HUD (Heads-Up Display) inside the helmets of teammates outside the robot.

D. Built-in Language Translator: Programmed with the nine known languages of the Americas and can hold 12 additional languages. It can recognize and monitor up to three different voices and two different languages or dialects. Level of accuracy is 98.7% with a three second delay when directed at one individual, but drops to 78% with a six second delay when translating three speakers simultaneously.

NG-V41 Viking

The Viking is an intimidating combat robot built for raw power, destruction and combat, though it also functions well in roles involving construction and demolitions. However, its primary design consideration is that of troop support and mobile artillery. The hulking Viking robot is a walking bunker with thick armor, an array of concealed weapons, and one nasty shoulder cannon. Its silhouette strikes fear into intelligent enemies and monsters alike. Ever mindful of 'upward mobility,' the design team spearheaded by **Ian Small, Daniel Ogle, Peter Smith and Ryan McDaniel**, made sure the Viking's weapons systems can be used to punch through enemy fortifications, demolish old buildings, take down dinosaurs and giant monsters with its own brutish strength and slashing Vibro-Claws the size of swords. The Viking is also ideal as a mobile, defensive bunker for towns, city-states and military bases, making it suitable for defense, assault and troop support.

The head is both a sensor and communications array as well as housing two conventional and two infrared searchlights, plus tactical cameras and bunny ear-like radar dishes. While they are supposed to be the 'horns' of the Viking's helmet, among many mercs and soldiers, they have earned the Viking the pet name of *Rabbit, Big Bunny* and *Killer Bunny*. None of which are meant to be derogatory. In fact, many like the nicknames precisely because they belie the destructive power of the big 'Bot.

The pilot and gunner sit in the chest, and there is seating for two passenger or additional crew members. The pilot drives the robot and operates the grenade launcher and claws. A dedicated gunner controls the main cannon and missile launchers.

In an exploration capacity, the Viking is not ideal unless one is looking for a defensive anchor for a larger caravan of robots and vehicles. All seats recline, making them suitable for sleeping, but there is also a small cab area with two bunk beds, and storage space for two suits of body armor or light power armor. Always a plus with explorers and soldiers out in the field for long periods, there is also a toilet with an ion vaporization system for waste, a wash basin and a tiny, closet-like shower; 200 gallons (757 liters) of water, plus a water purification and filtering system is standard.

The robot is so big and so heavy that it requires a massive venting and cooling system, but has enough armor (one of the most of any NG robot ever put on the market) that it can take on and hold its own against 1-3 Glitter Boys. An impressive feat. If it had better speed (impossible for NG engineers if they want to keep the armor), it would be an even better-selling item.

Model Type: NG-V41 Viking.

Class: Infantry Assault and Tactical Support Robot.

Nicknames: Rabbit, Big Bunny and Killer Bunny.

Crew: One pilot and gunner. Can accommodate two additional passengers; four under cramped conditions.

M.D.C. by Location:

* Sensor Head – 200

* Head Searchlights (4) – 10 each

* Radar Dishes (4, top of head) – 15 each

* Grenade Launcher (1, mouth) – 25

* Communication Antennas (2, left shoulder) – 10 each

Main Gun (1, right shoulder) – 140

* Shoulder Missile Launcher Coverings (2, plate) – 75 each

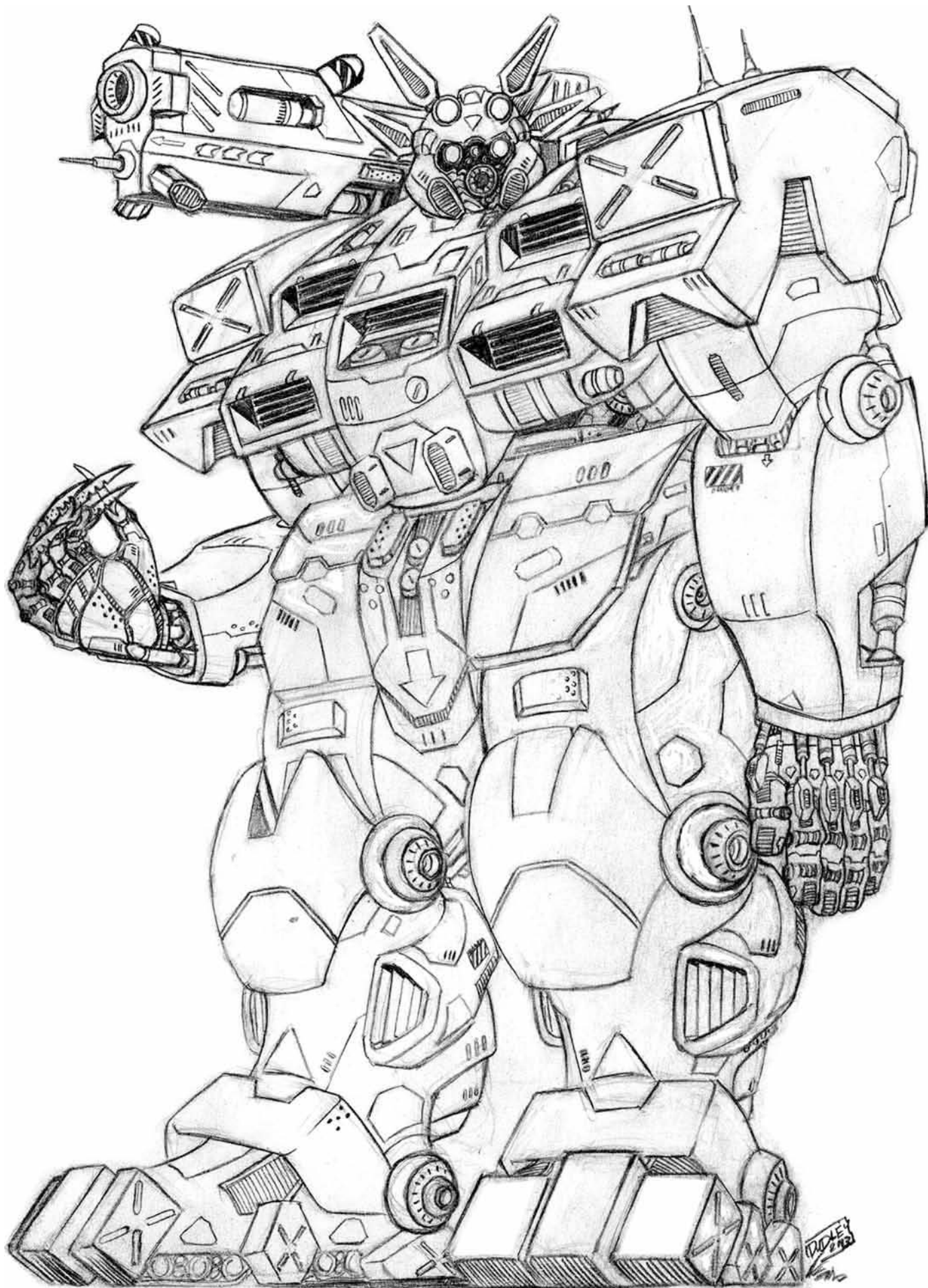

** Shoulder Missile Launchers (2, inside covers) – 25 each
Upper Arms (2) – 260 each
Forearms (2) – 240 each
Hands (2) – 100 each
* Vibro-Claws (5 per hand) – 25 each
Legs (2) – 350 each
* Feet (2) – 200 each
* Leg Lights (2 per leg) – 12 each
Reinforced Pilot Compartment – 100
*** Main Body – 745

* A single asterisk indicates a small or difficult target to strike, requiring the attacker to make a ‘Called Shot,’ but even then is -3 to strike.

** The actual missile launchers, concealed under the flip-top armored plating, are vulnerable to attack only when the lid is flipped up to fire, and when it has been destroyed (reduced to zero or less M.D.C.).

*** Depleting the M.D.C. of the main body will shut the vehicle down completely, making it useless.

Speed:

Running: 45 mph (72 km).

Leaping: Limited. With a running start, 6 feet (1.8 m) high and 12 feet (3.6 m) across.

Water: The Viking is not designed for use in water, but can walk along the bottom of lakes and seas at 20 mph (32 km). Maximum depth 2,500 feet (762 m).

Flying: Not possible.

Statistical Data:

Height: 29 feet (8.8 m).

Width: 15 feet (4.6 m).

Length: 14 feet (4.3 m).

Weight: 54 tons.

Physical Strength: Equal to a Robotic P.S. 45.

Cargo: In addition to the sleeping cab and bunk with two footlockers, there is a small weapon locker with 4 rifles, 4 pistols, 4 smoke grenades, 8 flares, 4 canteens, 2 survival kits and one first aid kit. There is space under each seat (4) for a backpack and a few personal items as well as two small cargo compartments like those on airliners, for the two passenger seats.

Power System: Nuclear; average energy life is 15 years. Solid Oxide Fuel Cell and electric battery versions are also available, but not recommended.

Cost: Nuclear: 64 million credits. Solid Oxide Fuel Cell: 56 million credits. Electric Battery: 52 million credits.

Weapon Systems:

1. NG-41G Automatic Grenade Launcher: What looks like the circular mouth area of the Viking is an automatic grenade launcher configured to fire three-round bursts. Burst fire helps conserve ammunition and increases the damage radius.

Primary Purpose: Anti-Personnel and Assault.

Secondary Purpose: Anti-Monster and Defense.

Range: 1,000 feet (305 m).

Mega-Damage per Three Grenade Burst: 2D6 M.D. to a 24 foot (7.3 m) radius for fragmentation grenades, 3D6 M.D. to a 12 foot (3.6 m) radius for high explosive/armor piercing grenades, 6D6 M.D. to a 24 foot (7.3 m) radius for plasma grenades. Smoke, HEX and tear gas grenades are considered ‘special ordnance’ and sold separately.

Rate of Fire: Each three grenade burst counts as one melee action/attack.

Payload: 120 round drum, enough for 40 bursts.

2. Concealed, Shoulder Missile Launchers (2): Each shoulder has a missile rack behind an armored plate. The armored door flips open, the missiles fire, and the door closes. The robot rolls off the assembly line with both shoulder launchers being the same type, mini-missiles or short-range. For 70,000 credits, any competent Operator can purchase and replace one of the shoulder launchers with the other to provided greater versatility. That said, many purchasers prefer having both shoulder mechanisms and missile types to be the same.

(Option A) Mini-Missile Launchers (2): Each shoulder sports a mini-missile rack behind an armored plate. The missiles give the Viking a ranged combat option for shooting down aircraft, other flyers and incoming missiles, as well as targets in the distance.

Primary Purpose: Anti-Aircraft, Anti-Missiles and Assault.

Secondary Purpose: Anti-Armor and Anti-Monsters.

Range: One mile (1.6 km).

Mega-Damage: Varies with missile type. Plasma (1D6x10 M.D.) and armor piercing (1D4x10 M.D.) are standard.

Rate of Fire: One at a time or in volleys of two or four.

Payload: 36 missiles per launcher, 72 total if both are mini-missile launchers. **Note:** Replacement mini-missiles generally cost 1,200-2,500 credits each, depending on type. See page 257 of **Rifts® Ultimate Edition** for prices.

(Option B) Short-Range Missile Launchers (2): Each shoulder contains a short-range missile launcher behind an armored plate. The missiles give the Viking a longer range combat option for shooting at aircraft, other flyers and targets in the distance.

Primary Purpose: Anti-Aircraft and Assault.

Secondary Purpose: Anti-Armor and Anti-Monsters.

Range: Five miles (8 km).

Mega-Damage: Varies with the missile type used. Standard load is armor piercing (2D6x10 M.D. to a 5 foot/1.5 m radius) or plasma (2D6x10 M.D. to a 15 foot/4.6 m blast radius).

Rate of Fire: One at a time or in volleys of two or four.

Payload: 12 short-range missiles per launcher, 24 total if both are short-range launchers. **Note:** Replacement short-range missiles generally cost 2,000-4,500 credits each, depending on type. See page 256 of **Rifts® Ultimate Edition** for prices.

3. NG-EV66 Heavy Plasma Cannon (1): Mounted on the right shoulder is a massive, heavy plasma cannon. The gun has a 45 degree up and down arc of fire and can turn side to side 20 degrees.

Primary Purpose: Anti-Aircraft and Assault.

Secondary Purpose: Anti-Armor and Anti-Monsters.

Range: 2,500 feet (762 m).

Mega-Damage: 1D6x10+6 M.D. per blast.

Rate of Fire: Each shot counts as one melee attack of the gunner.

Payload: Unlimited when tied to the nuclear power supply. Most Solid Oxide Fuel Cell systems provide a separate Solid Oxide power supply (4 cells) for the cannon itself, giving it a 1D4 week payload with frequent use. Electric battery systems also provide the cannon with its own battery supply that lasts 4D6+20 hours with frequent use of the cannon (double with infrequent use).

4. NG-L41 Concealed Arm Lasers (2): A small forearm laser is built into each wrist of the Viking. When needed, it rises up from its housing to fire.

Primary Purpose: Anti-Personnel and Cutting.

Secondary Purpose: Assault and Defense.

Range: 2,000 feet (610 m).

Mega-Damage: 3D6 M.D. per single blast. Dual blasts are not possible.

Rate of Fire: Each shot counts as one melee attack.

Payload: Effectively unlimited, or as per the duration of alternative energy systems.

5. Vibro-Claws (5): Each finger of the right and left hand has a serrated cutting blade that can extend and retract from the robot's finger housing. Used for combat, cutting, digging/mining and excavation.

Primary Purpose: Anti-Fortification and Assault.

Secondary Purpose: Labor and Defense.

Range: 17 foot (5.2 m) reach.

Mega-Damage: 4D6 M.D. for a slashing or stabbing attack *without* the Vibro-edge activated. 6D6+4 when four or five of the blades are extended and the Vibro-Blades activated.

6. Hand to Hand Combat: Rather than use a weapon, the pilot can engage in Mega-Damage hand to hand combat as per Robotic P.S. 45. See *Heavy Ground Robot Training* on page 352 of **Rifts® Ultimate Edition** for the number of attacks and bonuses. Same as listed except as follows:

Restrained Punch – 1D6 M.D.

Punch – 3D6 M.D.

Power Punch – 1D6x10 M.D., counts as two melee attacks.

Claw Strike – 4D6 M.D.

Vibro-Blade Claw Strike – 6D6+4 M.D.

Crush, Pry or Tear: 4D6 M.D.

Dig (with hands) – 2D6 M.D. +2D6 M.D. with claws extended.

Kick – 5D8 M.D.

Leap Kick – Not possible.

Stomp – 2D4 M.D. but is only possible against targets eight feet (2.4 m) tall or smaller.

7. Sensor Systems of Note: The Viking has all the standard robot features, plus the following. The head of the robot has various sensor and communications arrays, spotlights, loudspeakers, and two cameras.

A. Communications and Data Relay Capabilities: Wide-band and directional radio communications system with built-in scrambler that transmits both audio and video from the cockpit, communications suite and battlefield video. Effective range of 500 miles (800 km); one third that range in the mountains, underground, and during storms. Includes the capability of sending and receiving scrambled/coded audio and video transmissions.

Audio pick-up and filtration system works both multi-directionally and as a shotgun mic. It can pick up sound as quiet as a whisper up to 400 feet away (122 m) and can sift through ambient sound for specific noises. Up to 100 hours of audio can be recorded and kept on file.

B. Tactical Cameras (6): The robot has two cameras in the head, one in each arm, one in the chest and one in the back. Can record a total of 8,000 hours of footage into memory. Video footage can also be transmitted live to one or more receivers, or stored and sent at a later time. Images are automatically

transmitted to the pilot and gunner inside the robot to monitors and HUDs; the pilot sees and fights via the cameras. If helpful, the images and data can be sent to the HUDs (Heads-Up Display) inside the helmets of teammates outside the robot.

C. Built-in Language Translator: Programmed with the nine known languages of the Americas and can hold 12 additional languages. It can recognize and monitor up to three different voices and two different languages or dialects. Level of accuracy is 98.7% with a three second delay when directed at one individual, but drops to 78% with a six second delay when translating three speakers simultaneously.

D. Head Searchlights (4): The two large lights in the top of the head are conventional lights. The two smaller ones that look like the eyes of the robot are infrared searchlights.

NG-V39 Volcano

The Volcano combat robot comes from the **Morpheus design team**, led by **Dan Deluca, Rosalena Butka, Amanda Butka** and **Scott Gibbons**. It is intended to fill a specific combat and monster-fighting role that the design team felt was lacking: fire. Most animals, even monstrous ones, as well as a fair number of supernatural monsters and creatures of magic, are vulnerable to fire, making the Volcano their worst nightmare. Also with monsters in mind, NG hopes the Volcano will be ideal for clearing out Xitcix nests and burning down their hives.

Bearing an impressive array of fire-based weapons, the Northern Gun Volcano is adept at torching everything around it, boiling infantry out of bunkers and armored vehicles, and scorching opponents who can't take the heat. With customers heading out into the endless tundra of Canada or the vast and icy American North, Northern Gun has provided the Volcano as a means for countering demons, monsters and aliens who are vulnerable to the elemental essence of fire.

The Volcano's main weapon is a long-range flamethrower. The weapon is mounted above the right shoulder, and is capable of burst fire or a sustained stream of flame. The big drum on the back of the Volcano contains an impressive amount of liquid ammunition for the heavy flamethrower.

The right forearm contains one of Northern Gun's most revolutionary and experimental weapons to date, a little something its designers call the Heatwave Emitter. The blocky weapon looks as if saws or Vibro-Blades should be sliding out of the three forward facing slots. Instead, they emit a heat ray that cooks the air in a tight, cylindrical cone in front of the emitter. It deals modest damage initially, and little damage to M.D. materials, but burns exposed flesh within a few prolonged blasts and causes flammable material to burst into flame, including hair and fur. See the weapon description below for full details.

The Volcano is also intended for ranging over long distances and traversing difficult terrain. It has good mobility as well as seating for two, the pilot along with a gunner or crew member, both riding safely within the robot's chest/upper body. The seats recline for naps and even sleeping inside the robot. There is a toilet with an ion vaporization waste disposal system, a water basin with a 100 gallon (378.5 liter) tank, and a second hundred gallon tank of drinking water. Volcanoes are best suited for raids and missions of sabotage, as well as burning out nests of monsters.

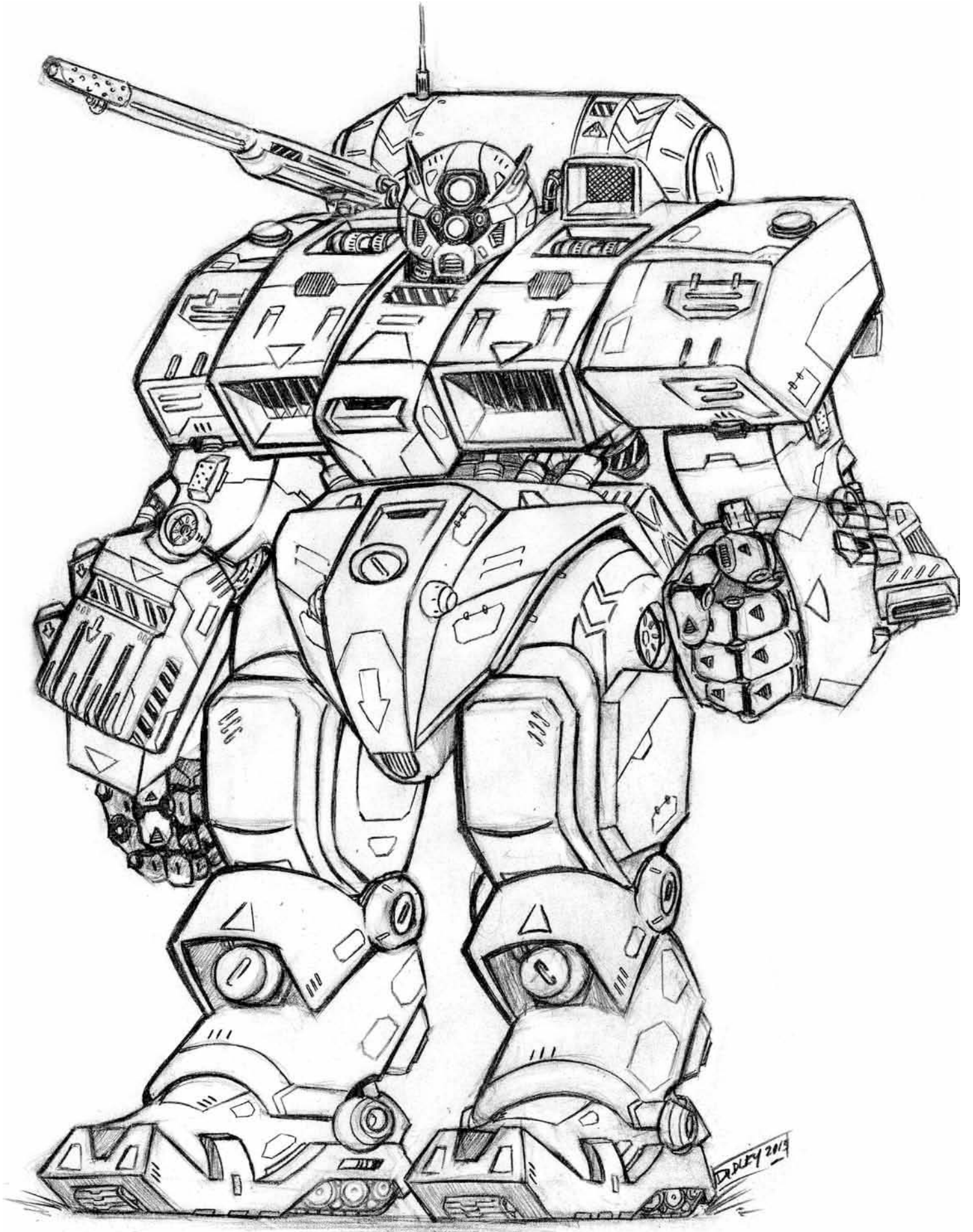

One (or a few) makes a nice addition to most robot squads and mercenary companies.

Model Type: NG-V39

Class: Infantry Assault Robot.

Crew: One pilot with room for one crewman/gunner or passenger.

M.D.C. by Location:

- * Sensor Head – 100
- * Heatwave Emitter (1, right forearm) – 70
- * Plasma Ejector (1, left forearm) – 50
- * Heavy Flamethrower – 75
- Flamethrower Fuel Drum (1, back) – 110
- Upper Arms (2) – 200 each
- Lower Arms (2) – 120 each
- * Hands (2) – 50 each
- Legs (2) – 200 each
- Feet (2) – 120 each
- Reinforced Pilot Compartment – 100
- ** Main Body – 400

* A single asterisk indicates a small and difficult target to strike, requiring the attacker to make a 'Called Shot,' but even then the attacker is -3 to strike.

** Depleting the M.D.C. of the main body shuts the vehicle down completely, making it useless.

Speed:

Running: 60 mph (96 km).

Leaping: With a running start, 10 feet (3 m) high and 16 feet (4.9 m) across.

Water: The Volcano is not designed for use in water, but can walk along the bottom at 25 mph (40 km). Maximum depth 1,000 feet (305 m). The Heatwave Emitter and flamethrower cannot be used underwater. The plasma ejector can be used, but only has a 400 foot (122 m) range.

Flying: Not possible.

Statistical Data:

Height: 24 feet (7.3 m).

Width: 15 feet (4.6 m).

Length: 12 feet (3.6 m).

Weight: 23 tons.

Physical Strength: Equal to a Robotic P.S. 40.

Cargo: Minimal, a small locker with enough room for a rifle, pistol, survival kit and a few personal items.

Power System: Nuclear; average energy life is 15 years. Solid Oxide Fuel Cell system is also available. Electric battery version is not suitable for this robot.

Cost: Nuclear: 38 million credits. Solid Oxide Fuel Cell: 31 million credits. Electric battery not available.

Weapon Systems:

1. NG-F139 Heavy Flamethrower: The weapon mounted over the right shoulder is the Volcano's long-range, heavy flamethrower. It is mounted on a turret that can sweep side to side 120 degrees and has a 90 degree up and down arc of fire. It fires spurts of burning napalm that can force infantry out of cover, take out bunkers, burn out monster nests and start fires.

Primary Purpose: Anti-Structure, Anti-Personnel and Assault.

Secondary Purpose: Anti-Monster and Defense.

Range: 600 feet (183 m).

Mega-Damage: 1D4x10 M.D. to the target and anyone within 10 feet (3 m). Those caught within reach of the flamethrower's attack inside small, enclosed areas like bunkers, caves or non-sealed vehicles and without environmental gear or oxygen, must roll to save vs poison (smoke inhalation and lack of air) or be rendered unconscious for 1D4 melee rounds.

Rate of Fire: Each blast counts as one melee attack.

Payload: Approximately 140 blasts. The flamethrower can be refueled with military-grade napalm or use normal diesel or gasoline (reduces damage to 3D6 M.D.). 260 gallon (984 liter) fuel tank.

2. NG-E39 Plasma Ejector (1): The Volcano features a forearm-mounted plasma ejector on the left arm. A straightforward, 'point-and-shoot' weapon with decent range.

Primary Purpose: Anti-Personnel and Assault.

Secondary Purpose: Anti-Armor and Defense.

Range: 1,600 feet (488 m).

Mega-Damage: 6D6 M.D. per blast.

Rate of Fire: Each blast counts as one melee attack.

Payload: Effectively unlimited.

3. NG-HE139 Heatwave Emitter (1): The right forearm is where NG's experimental Heatwave Emitter is mounted. The blocky weapon emits a heat ray that cooks the air in a tight, cylindrical cone directly in front of it. Think of an ant placed under the focused heat beam of a magnifying glass. Targets, especially S.D.C. targets, immediately feel incredibly hot and uncomfortable, like being suddenly exposed to the heat of a blast furnace. After the equivalent of two heat blasts, their skin starts to turn red as if sunburnt. Sustained use of the Heatwave blast can boil water in seconds (three blasts) and create flash steam (four blasts), shrivel vegetation (three blasts), and cause exposed gasoline, tinder, dry grass, straw and old rags to burst into flames (one blast). Human hair and animal fur burst into flame after the equivalent of three blasts, clothing in five, and S.D.C. plastic and rubber in six (they start to soften and melt in two). Wood begins to char and scorch after the equivalent of three blasts and catches fire in eight. The Heatwave Emitter can even cremate the remains of the living, burning away flesh and muscle in the equivalent of 10 blasts and turning bone to ash in 36.

To achieve serious damage, the beam must be kept trained on the item/target until the exposure to the intense heat has the desired effect. The Heatwave Emitter can only fire four blasts per melee round (15 seconds). To aim the weapon at a different target breaks the time of exposure (measured by blast equivalents). When the weapon is trained back on the target/material, the Heatwave damage starts anew from the beginning. This makes it less effective against moving targets. (Roll to strike as if it is a new blast/attack, requiring a successful strike to keep the beam on the moving target and apply continuous damage.) Likewise, it inflicts comparatively light damage to M.D.C. armor, structures and creatures, but can annihilate S.D.C. beings, set ablaze S.D.C. material in seconds, inflicts double damage to beings vulnerable to heat or fire, and is a potent intimidation weapon. (Of course, it does no damage to beings or materials impervious to heat or fire; including those protected by magic or psionics.)

There are **strategic applications** for this weapon too. For example, setting fire to create a diversion or distraction, creating smoke to cover an attack or escape, acts of sabotage by

burning/melting wiring or a key component (even a handle or switch), overheating computers, causing them to temporarily lock up or shut down, knocking out heat sensors (one heat blast to a thermal sensor or optics system temporarily knocks it out [blank red screen] for 1D4 melee rounds), and similar uses. **Note:** See Danger of Overload for potential problems with this weapon system.

Primary Purpose: Anti-Personnel and Assault.

Secondary Purpose: Sabotage.

Range: 500 feet (152 m).

Mega-Damage: One M.D. point of damage for a single blast or two. However, keeping the Heatwave trained on a target for more than two blasts starts to inflict more damage: 1D4 M.D. for the rest of the melee round (next two blasts), and 1D4 M.D. for each subsequent blast that stretches into the next and subsequent melee rounds. This slowly does damage and can be used to melt through M.D.C. locks, hinges, chains, wire, and even cut through M.D.C. walls and doors. It may take several minutes, even an hour or two, but it can be done.

S.D.C./Hit Point Damage: One S.D.C./Hit Point damage for a single blast and as described above. Dry brush, dry grass, straw, and most flammable materials not locked up in a sealed container instantly burst into flames when struck by a single Heatwave blast.

However, keeping the Heatwave trained on a target for more than the equivalent of two blasts starts to inflict an ever-increasing amount of damage. The following applies to all S.D.C. material and Hit Point beings when the beam is KEPT ON THEM without pause. Continuous exposure measured by *blasts*: The third continuous blast does 1D4 S.D.C., the fourth 2D4 S.D.C., the fifth 2D6, the sixth 4D6 S.D.C., the seventh 8D6 S.D.C., the 8th does 2D4x10 S.D.C., the 9th 2D6x10 S.D.C., the 10th 4D6x10, the 11th 1D4x100 S.D.C., the 12th 1D6x100 S.D.C., the 13th 2D6x100 S.D.C., the 14th blast on continues to inflict 2D6x100 S.D.C. points of damage per subsequent and continuous blasts.

Note: We want to stress for clarity that this cumulative damage applies only when the *same target* is *continuously blasted* in what is an *unbroken exposure* to the heat ray.

If the ray is shot at fourteen different targets in that same time frame, each one, be it target number one or target number fourteen, would only suffer ONE S.D.C. point of damage. Two sustained blasts to the same target, 2 S.D.C. (one per each of the two blasts). However, if that same target was struck with a third blast (actually a sustained heat beam that never stopped), that third blast does 1D4 S.D.C. after about 11 seconds of continuous exposure. NOW, further sustained, unbroken exposure to the heat ray starts to inflict escalating damage as described above (2D4, 2D6, 4D6, and so on).

Rate of Fire: Maximum of four blasts or one continuous beam (equal to four blasts) per melee round. Each blast counts as one melee attack.

Payload: Effectively unlimited when tied to the robot's power supply.

Danger of Overload: This is a new and experimental device. After 12 blasts or a sustained beam for 45 seconds (three melee rounds), there is a 5% chance of overheating. The chance for overheating is cumulative and increases by 5% every three melee rounds. (10% after six melees, 15% after nine, 20% after 12, 30%

after 18 melee rounds, 50% after 30 melee rounds, 100% after 60.) Roll percentile dice every three melee rounds.

When overheating occurs, the weapon shuts down for 1D6x10 minutes as a failsafe mechanism. If the failsafe is disabled or doesn't work (01-25% chance), the weapon can fire for another 2D6 melee rounds, but burns out completely at the end of that period. (The G.M. should roll secretly, and write the number down on sheet of paper. When the weapon burns out, he/she announces it at the beginning of that melee round. "The weapon stops working. It's burned out and your Volcano robot takes damage.") When a Heatwave Emitter burns out, it inflicts 2D6x10 M.D. to the *right hand and arm* of the robot. If the limb is not destroyed, it is frozen; immobilized and useless, and inflicts a -5% piloting penalty. Also roll to see if the overload caused the Flamethrower fuel tank to explode. There is only a two percent chance of this happening (01-02% on a percentile roll), but if it does, the tank explodes, inflicting 2D6x10 M.D. to the main body and sensor head. If the head is destroyed, sensors are knocked out: -4 on all combat rolls (initiative, strike, parry, dodge, etc.), reduce speed by 20% and suffer a -20% piloting skill penalty.

4. Hand to Hand Combat: Rather than use a weapon, the pilot can engage in Mega-Damage hand to hand combat as per Robotic P.S. 40. See *Heavy Ground Robot Training* on page 352 of **Rifts® Ultimate Edition** for the number of attacks and bonuses. Same as listed except as follows:

Restrained Punch – 1D4 M.D.

Full Strength Punch – 2D6 M.D.

Power Punch – 4D6 M.D., counts as two melee attacks.

Kick – 3D8 M.D.

Leap Kick – Not possible.

Stomp – 1D6 M.D. but is only possible against targets six feet (1.8 m) tall or smaller.

5. Sensor System Note: Same as the Viking, previously described.

NG Weapons

Northern Gun Production Blocks

With many of its products enjoying years of popularity and sales success, Northern Gun is always working to improve the effectiveness of its weapons and the efficiency of its assembly lines. When a particular unit seems past its prime, the Trade Council puts together a special commission of scientists and engineers to bring it up to speed. They apply lessons learned from reverse-engineering alien and foreign products, as well as years of honest experience and tinkering to craft a more modern version. When a new design is created, it is designated as a new production 'block' in order to help sales staff distinguish between old and new models.

Most of the robots, power armor, vehicles and weapons that Northern Gun offers are still in their first production block, but Block II models are relatively common, and older units like Samson power armor have already gone into Block III and even completely new designs inspired by the original.

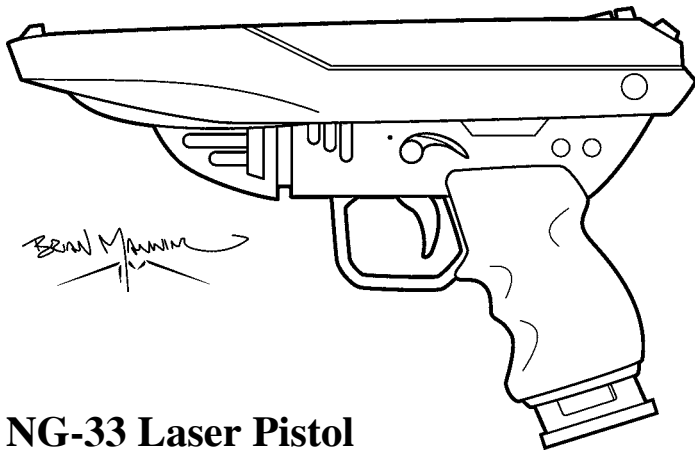

NG-33 Laser Pistol

A trusty side arm offered by Northern Gun, the NG-33 has been upgraded by NG engineers led by **Jonathan Harris** and **Thomas Schrapp** over the years to develop a slightly more powerful weapon, but still retains all of its signature NG ruggedness and dependability.

Weight: 4 lbs (1.8 kg).

Range: 800 feet (244 m).

Mega-Damage: 1D6 M.D. per blast for the original Block I weapon. 2D4 M.D. for the NG-33 Block II; same price.

Rate of Fire: Each shot counts as one melee attack.

Payload: 20 shots.

Cost: 6,500 credits.

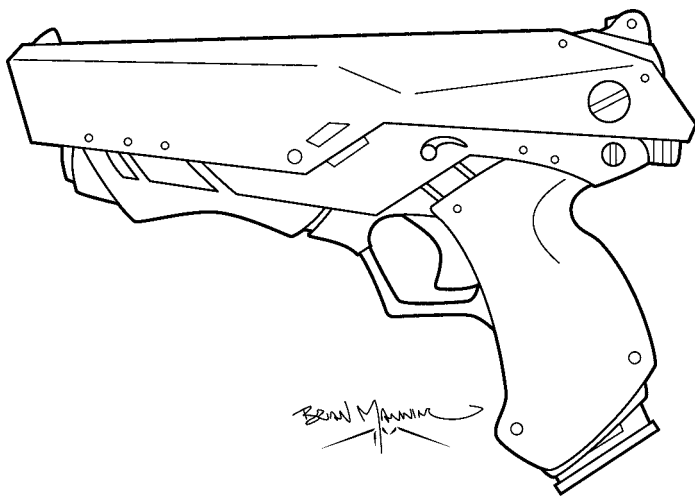

NG-35 Heavy Laser Pistol (new)

Northern Gun is known for their heavy, durable infantry weapons, but most laser pistols are typically light, small guns. To appeal to its customer base of macho types and individuals with enhanced strength, an NG design team spearheaded by **Robert Edmunds** and **Phillip A. Compher** has created a new high-powered laser pistol. The NG-35 is a big, bulky weapon with good range, good firepower and is still sturdy enough that it can be used just fine as a cudgel. No one will mistake it for a Triax or Wilk's product, which is how Northern Gun likes it.

Weight: 4.5 lbs (2 kg).

Range: 800 feet (244 m).

Mega-Damage: 3D6 M.D.

Rate of Fire: Each shot counts as one melee attack.

Payload: 14 shots, 22 with a long E-Clip.

Cost: 19,500 credits.

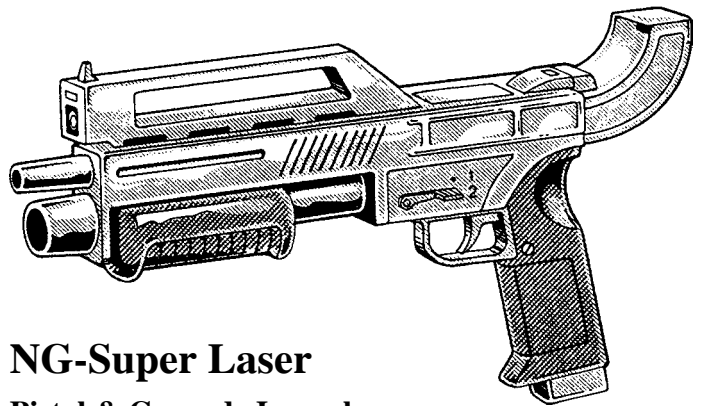

NG-Super Laser

Pistol & Grenade Launcher

One of the weapons that put the 'Gun' in Northern Gun was conceived by the legendary weapon designer **K.H.S.** It is the *NG-Super Laser Pistol*, which reflects the limitations of the company's early manufacturing methods. While it is certainly a reliable weapon, it is heavy and bulky, more of a submachine-gun than a real pistol. The secondary grenade launcher is a handy feature, but adds weight and kicks like a mule. The overall result is a weapon more useful to Juicers, Crazies, cyborgs and powerful D-Bees than normal humans, though particularly strong individuals sometimes use it to show off.

Weight: 13 lbs (5.8 kg).

Range: Laser 800 feet (224 m), grenade launcher 500 feet (152 m).

Mega-Damage: Laser 2D4 M.D., grenade launcher 2D6 M.D. to a blast area of six feet (1.8 m) in diameter.

Rate of Fire: Each grenade or laser blast counts as one melee attack.

Weight Penalties: Characters with a strength of 19 or less are -3 to strike firing one-handed, and -1 to strike when bracing it with both hands or on something, whether firing the laser or grenade launcher.

Payload: Laser is 20 blasts, Grenade Launcher carries six grenades hand loaded into the gun plus eight spares that can be loaded into a top-feeding clip by hand.

Reloading the Launcher: Requires one full melee round (15 seconds), to manually reload the grenade launcher. As always, reloading an E-Clip takes about five seconds or equal to one melee attack.

Cost: Original price 21,000 credits. For a while the price dropped to 11,000 to 15,000 credits for a used weapon. New ones still list at 21,000 credits, but the weapon is often featured in sales that drops the price to the same price range as used. Grenades cost 400 credits apiece or 3,800 a dozen.

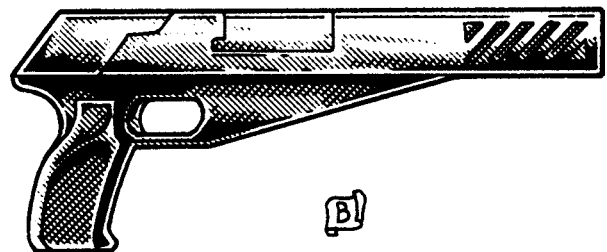

NG-45LP Long Pistol

The lead designers, **Jason Domke** and **Frederic Christie**, were thrilled to see the NG-45LP become an instant hit with customers. Many feel Northern Gun's Long Pistol is really a medi-

um-range energy rifle or carbine in a pistol-shaped design. Juicers and others with augmented strength like it because they can wave around a pistol that has rifle-like firepower with one hand. Pilots, crewmen and travelers like it because it is compact enough to be stowed in a vehicle compartment or piece of luggage. If it has a drawback, it's its low payload.

Weight: 5 lbs (2.25 kg).

Range: 1,200 feet (366 m).

Mega-Damage: 5D6 M.D. per shot.

Rate of Fire: Each shot counts as one melee attack.

Payload: 8 shots.

Cost: 15,000 credits; often sells for 50% to 200% more than the NG list price on the secondary market. Even the Black Market sells this weapon at a mark-up. Poor availability at list price. Good availability at higher prices.

NG-LP25

Laser Pulse Submachine-Gun

Conceived by lead designers **James Briggs** and **Barry Buse**, the LP25 is a hot seller, particularly in urban markets. Light and unobtrusive, its pulse capabilities let the small weapon dish out as much damage as comparable rifles. With a short E-Clip the LP25 fits neatly under a coat or cloak, and with a long E-Clip or Power Pack, it can maintain consistent suppressive fire for clearing rooms or shoot-outs in alleys and bars. Famous for its use as standard equipment by the Crisis Response Officers of Ishpeming's police force, the weapon is also extremely popular amongst gangs and Black Market criminals.

Weight: 4 lbs (1.8 kg).

Range: 1,000 feet (305 m).

Mega-Damage: 2D6+1 M.D. per single shot, or 5D6 M.D. per rapid-fire, triple shot pulse.

Rate of Fire: Each blast or triple pulse counts as one melee attack.

Payload: 21 single blasts or 7 pulse bursts per standard (short) E-Clip, or 36 single and 12 burst shots for a long E-Clip.

Cost: 19,000 credits.

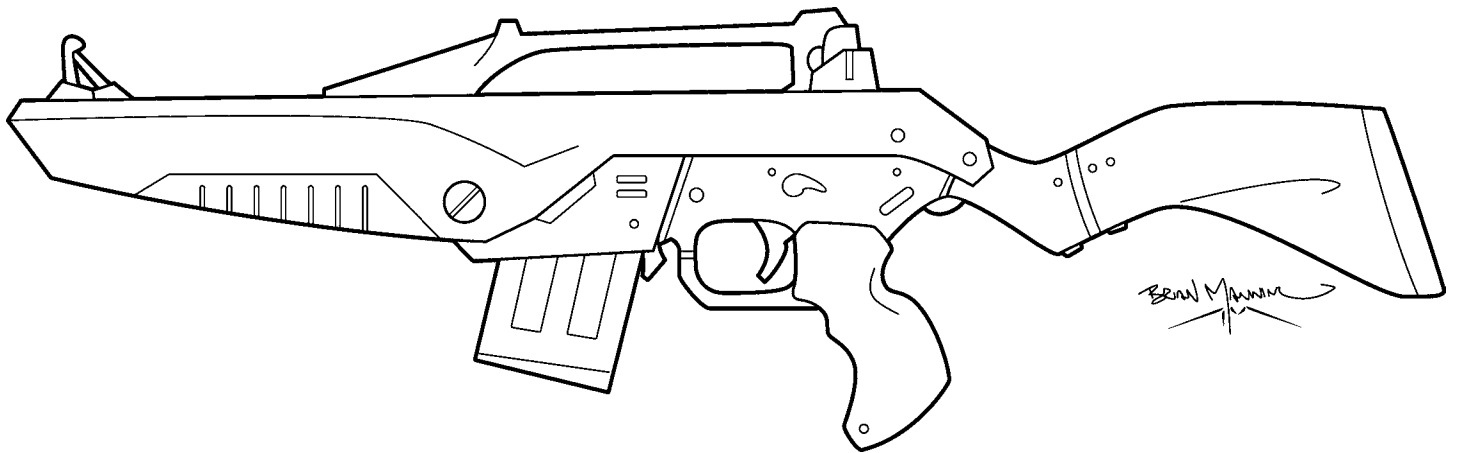
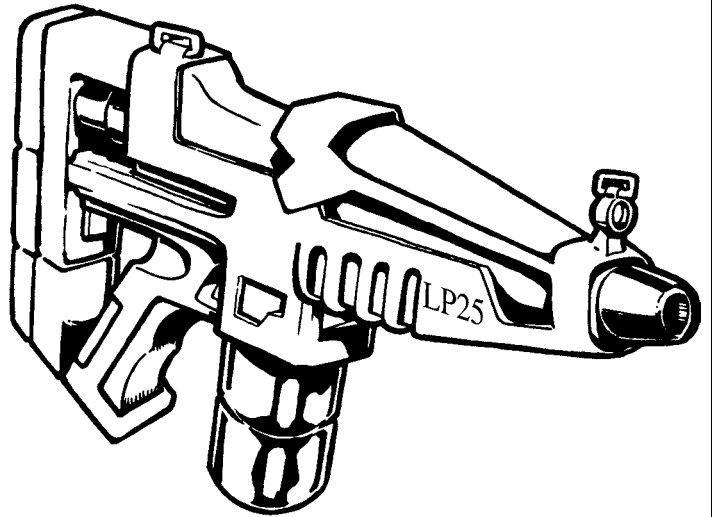

NG-L5 Laser Rifle

The standard amongst Northern Gun's laser rifles and a strong seller for many years, is the creation of **Becky Northaven** and **Kimihoro Hamaura**. The L5 is remarkably durable and resilient in the field, (it was on the market for two full years before a client reported a misfire). However, it can be quite a burden for a soldier to carry. NG's technicians have been cutting the weapon's weight down with each production block, and the *new Block III* rifles are slimmer and lighter, but still tough enough to be used as a club if necessary.

Weight: Block One: 14 lbs (6.3 kg). Block Two: 12 (5.4 kg), and 10 lbs (4.5 kg for the NG-L5 Block III).

Range: 1,600 feet (488 m).

Mega-Damage: 3D6 M.D. per blast.

Rate of Fire: Each shot counts as one melee attack.

Payload: 10 shots standard clip or 20 shots long E-Clip.

Cost: 16,000 credits.

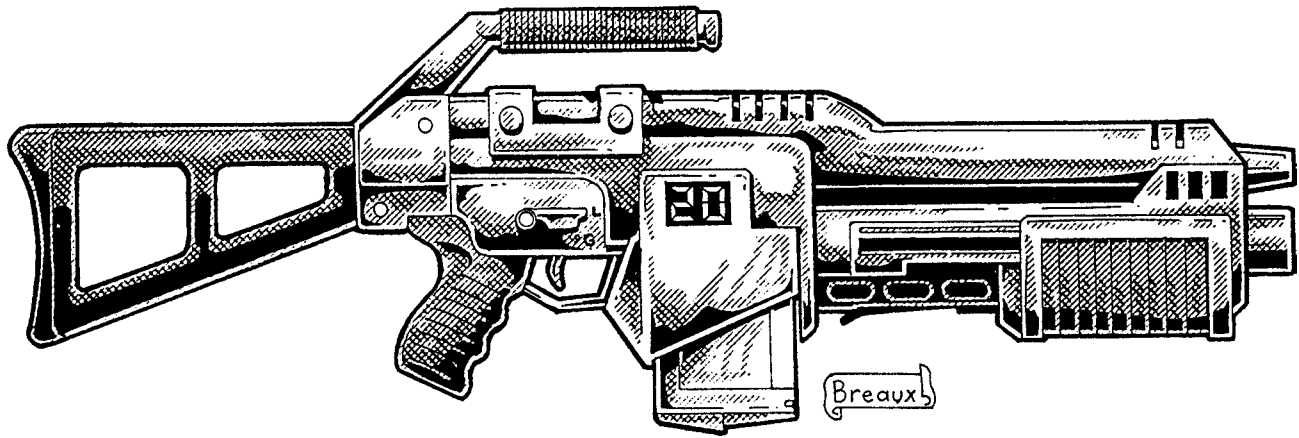

NG-LG6 Laser Rifle and Grenade Launcher

An L5 Laser Rifle mated with a full-size grenade launcher, the LG6 can unleash any grenade type in NG's inventory. It was introduced by lead designers **Cerbelaud Bruno** and **Benjamin Barbre** to compete with Coalition weapons and is favored by mercenaries and soldiers more so than outlaws; truly designed for the open battlefield.

Weight: Block I: 19 lbs (8.6 kg). Block II: 15 lbs (6.8 kg).

Range: Laser: 1,600 feet (488 m). Grenade launcher 1,100 feet (335 m).

Mega-Damage: 3D6 M.D. per laser blast or 4D6 M.D. to a blast radius of about 12 feet (3.6 m) per grenade. See the GL-10 Grenade Launcher for more grenade types.

Rate of Fire: Each shot counts as one melee attack.

Payload: Laser: 10 shots standard E-Clip, or 20 shots long E-Clip, or 70 shots with power pack (pack weighs 12 lbs/5.4 kg and regenerates 4 blasts per hour; costs 70,000 credits). Grenade launcher: Four grenades (pump action). Requires one melee attack/action to reload.

Cost: Block I: 20,000 credits. Block II: 22,000 credits. Grenades cost 400 credits each.

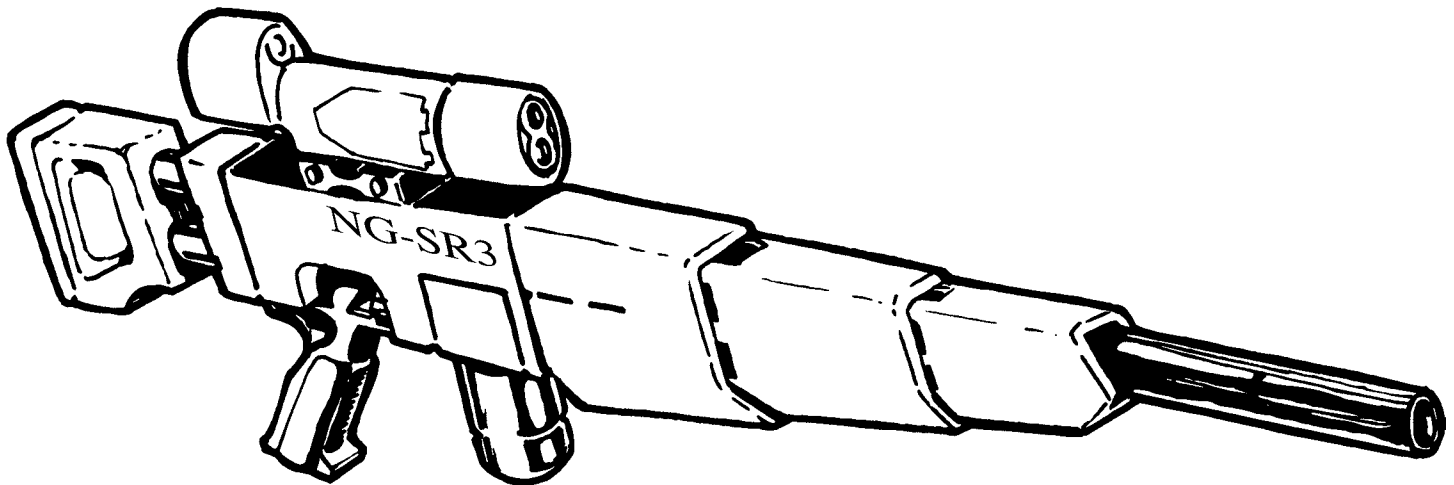

NG-SR3 'Marksman' Collapsible Sniper Laser Rifle

The Marksman is the precision laser rifle that Northern Gun's Research & Development division turned out after years of studying Wilk's and Triax products. The leaders of that design team, **Jeff Bunde**, **Michael Smith** and **Matthew Newton**, produced a surprisingly sophisticated and compact weapon for an NG design. The rifle is collapsible, breaking down into five component parts (takes 15 seconds/one melee round) that fit neatly inside a briefcase or bag, or can be concealed amongst one's garments. Banned for sale within the Coalition and Free Quebec, the SR3 is highly sought out by assassins and hit men across the continent.

Note: Comes standard with a basic telescopic sight and passive nightvision scope (both 2,000 foot/610 m range).

Weight: 8 lbs (3.6 kg).

Range: 2,400 feet (731.5 m).

S.D.C. Damage: The weapon has an S.D.C. setting that inflicts 1D6x10 S.D.C. per shot.

Mega-Damage: 3D6 M.D. on the medium setting or 4D6 M.D. for the high intensity laser setting.

Rate of Fire: Each blast counts as one melee attack.

Payload: A standard E-Clip provides enough energy for 5 high-intensity or 10 medium M.D. shots; S.D.C. firing drains far less energy. It takes five S.D.C. blasts to drain the same power as a single medium M.D. blast. Long E-Clips double the payload.

Bonus to Strike: +2 to strike on an Aimed shot.

Cost: 32,000 credits.

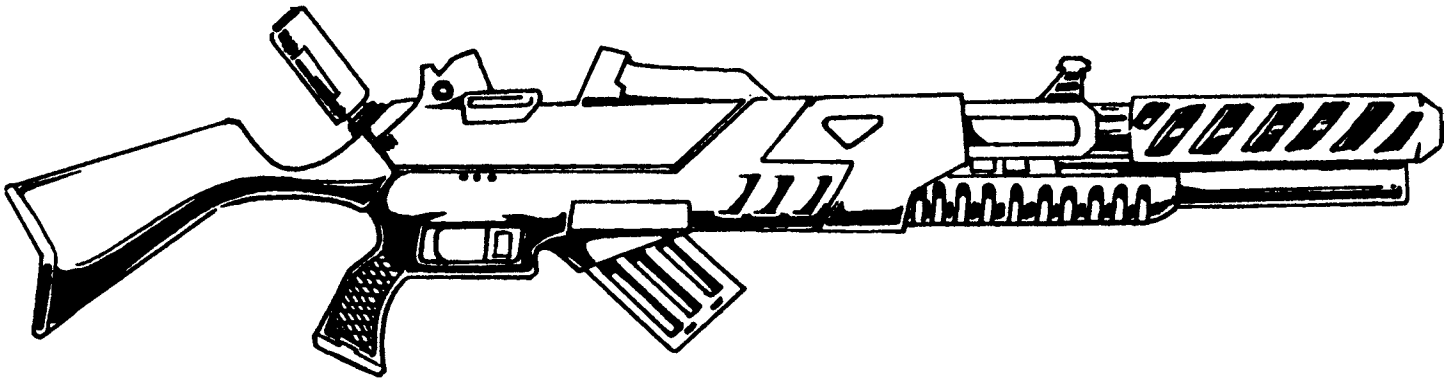

NG-SL20 Sniper Laser Rifle

'Inspired' by the Triax TX-SL12, Northern Gun's SL20 Sniper Laser Rifle is really just a direct knock-off. The laser itself is standard enough, but the rifle has impressive laser targeting and self-balancing capabilities that makes the beams much more accurate. The targeting system takes a moment to line up properly, however, making the weapon unfit for rapid fire. To compensate, Northern Gun has added an ion blaster that can take over in close quarters or when there isn't time to carefully aim each shot.

Weight: 10 lbs (4.5 kg).

Range: Laser: 3,000 feet (914 m). Ion Blaster: 1,000 feet (305 m).

Mega-Damage: Laser: 4D6 M.D. Ion Blaster: 3D6 M.D.

Rate of Fire: Each laser shot fired requires two melee actions to aim and shoot. Each ion blast counts as one melee action/attack.

Payload: 5 laser shots or 10 ion blasts.

Targeting Bonus: +3 to strike thanks to laser targeting and superior balance for the laser, but only +1 when using the ion blaster for assault purposes.

Cost: 50,000 credits.

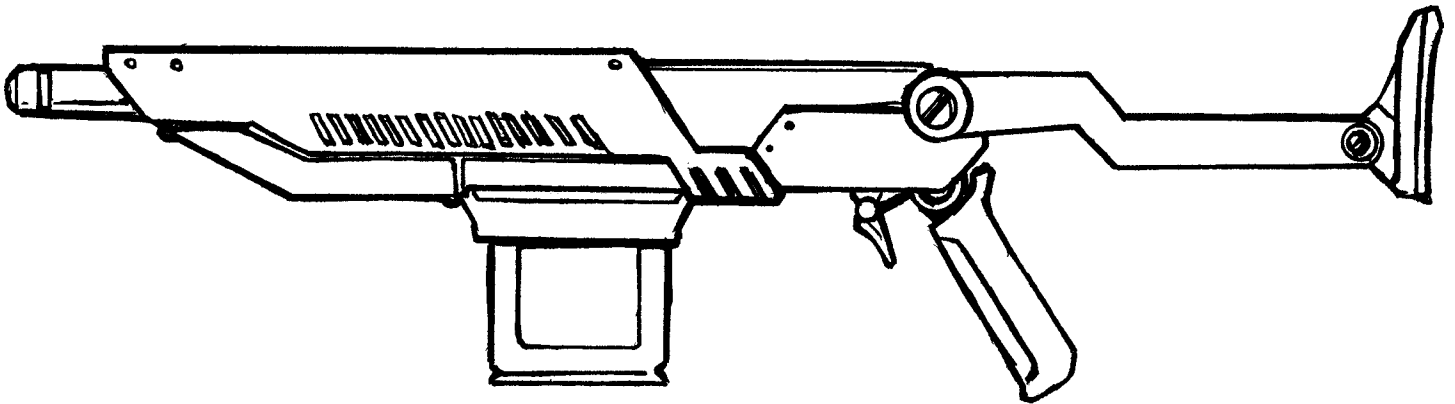

NG-SSL20 Super-Sniper Laser Rifle

A large, high-powered sniper laser rifle, the SSL20 is bulky, but makes up for it with accuracy and energy output. Its sensitive optics are a bit troublesome at times (requires two melee attacks/actions for an Aimed shot), but snipers who have time to lie in wait for a target prefer the greater precision over a faster rate of fire. Lead designers **Ron Guest** and **Jeff Farrar** are responsible for this weapon.

Weight: 10 lbs (4.5 kg).

Range: 2,000 feet (610 m).

Mega-Damage: 6D6+6 M.D. for the laser; single shot only.

Rate of Fire: Each shot counts as two melee attacks.

Payload: 6 laser blasts per short E-Clip or 12 laser blasts per long E-Clip.

Bonus to Strike: +1 to strike on Aimed attacks in addition to the character's usual bonuses.

Penalty to Strike: -1 to strike when used for anything other than an Aimed shot.

Cost: 60,000 credits.

Seasnake Series Lasers

In a bid to dig into its competitors' pockets, Northern Gun has introduced the *Seasnake line* of energy weapons. Based off the company's earlier blue-green laser designs, each Seasnake is powered by a low-cost capacitor and energy refraction system that produces blue-green laser light. Every Seasnake laser weapon works when submerged and has vents that allow water to drain when the weapon is brought onto dry land.

The Seasnake series are manufactured to be light and handy. They sport thin barrels and features like folding stocks that cut down on size and weight. NG marketing's intention is to make a separate line of guns more akin to Wilk's products, going against the company's reputation for heavy, sometimes even clunky weapons. Their hope is that customers will replace their purchases of Wilk's and other small arms with the competitively priced Seasnake series. Add in the benefit of underwater functionality that comes from the blue-green energy, and the Seasnake lineup becomes a real threat to other arms manufacturers' profits. NG is currently selling the weapons at cut-rate prices in an attempt to aggressively displace Wilk's sales presence.

With its lighter weight and distinctly non-Northern Gun appearance, many customers, especially illiterate ones, aren't even aware that they are buying an NG product when they purchase a Seasnake weapon. Rain and water corrosion are no problem for the completely waterproof, high-impact, M.D.C. plastic used to make the laser's weapon casings. And for shooters who don't necessarily need a gun that can fire underwater, each Seasnake is still a quality, well-priced weapon, and the ability to pick off opponents who try to dive into the water for safety doesn't hurt either. Favored by naval forces, pirates and aquatic D-Bees. **Range Note:** The range for the Seasnake line is applicable both underwater and above water in an atmosphere. Lead designers for the series were **Andrew Antolick, James Chance, Alan Jones** and **John Frederick**.

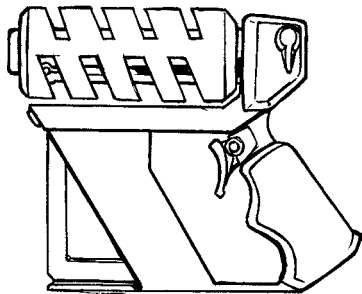

NG-SE3

Laser Emergency Side Arm (new)

Small and handy like the NG Holdout, the Seasnake SE3 is intended for use by sailors, marines, pilots and outdoorsmen. It has limited range and power but can be easily stowed in a boot or tucked into a belt or waistband. Divers often use the SE3 as an emergency backup weapon in case they have to defend themselves while submerged.

Weight: 0.5 lbs (0.22 kg).

Range: 600 feet (183 m).

Mega-Damage: 1D4+1 M.D.

Rate of Fire: Each shot counts as one melee attack.

Payload: 20 shots per standard E-Clip.

Cost: 6,000 credits.

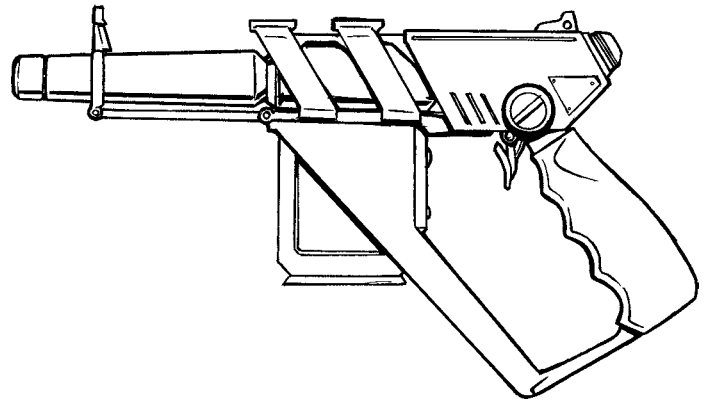

NG-SE5 Laser Pistol (new)

The SE5 is the standard Seasnake handgun. It is a light, reliable weapon, good as a backup for sailors or marines or anyone who needs a quality laser pistol at their side.

Weight: 1.5 lbs (0.68 kg).

Range: 800 feet (244 m).

Mega-Damage: 2D4+2 M.D.

Rate of Fire: Each shot counts as one melee attack.

Payload: 24 shots per standard E-Clip, 38 with a long E-Clip.

Cost: 7,500 credits.

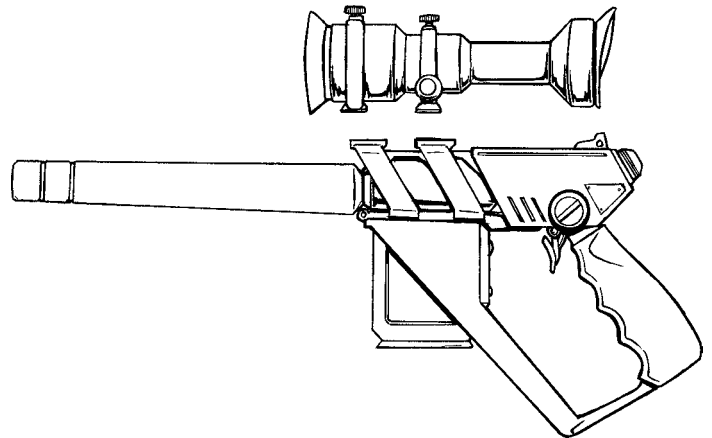

NG-SE9 Sharpshooter Laser Pistol (new)

The NG-SE9 looks very much like the SE5, but with a larger barrel and telescopic, passive nightvision scope that comes standard with the pistol. The Sharpshooter Laser Pistol is perfect for fending off sea monsters, ship-to-ship battles at medium range and precision shooting. In fact, it is a favorite among marksmen, hunters and target shooters. It is also extremely popular with pirates, sailors and aquatic D-Bees who enjoy a weapon with good range and power for a precision weapon, but do not wish to be encumbered by a rifle.

Weight: 2.5 lbs (1.1 kg).

Range: 1,000 feet (305 m).

Mega-Damage: 3D4+3 M.D.

Rate of Fire: Each shot counts as one melee attack.

Payload: 20 shots, 36 with a long E-Clip.

Cost: 15,000 credits with a telescopic targeting scope with passive nightvision and laser distancing features (1,500 foot/457 m range for the distancer and 3,000 feet/914 m for the telescopic scope).

NG-SE14 Laser Burst Pistol (new)

Made expressly for boarding parties and amphibious assault troops, the Seasnake SE14 blurs the line between pistol and submachine-gun. It can be set to fire a “double-tap” of two laser beams back to back, dishing out more damage but burning through E-Clips at a faster rate. In the kind of close-up, short-lived combat that the SE14 is made for, however, conserving ammunition takes second place to sheer firepower.

Weight: 4 lbs (1.8 kg).

Range: 800 feet (244 m).

Mega-Damage: 1D6+4 M.D. for a single blast or 2D6+6 M.D. for a dual burst.

Rate of Fire: Each shot or burst counts as one melee attack.

Payload: 20 single shots or 10 bursts with a standard E-Clip. 32 single or 16 dual blasts with a long E-Clip.

Cost: 17,000 credits.

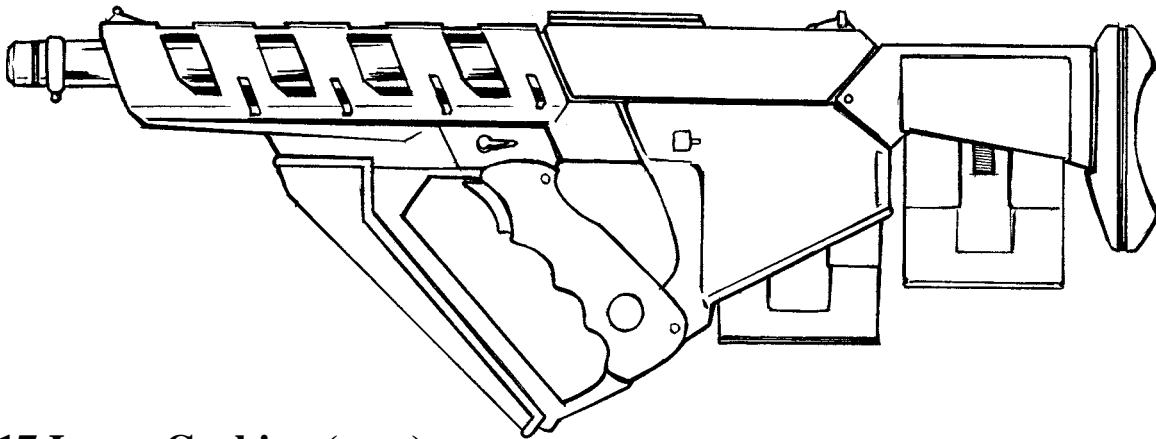
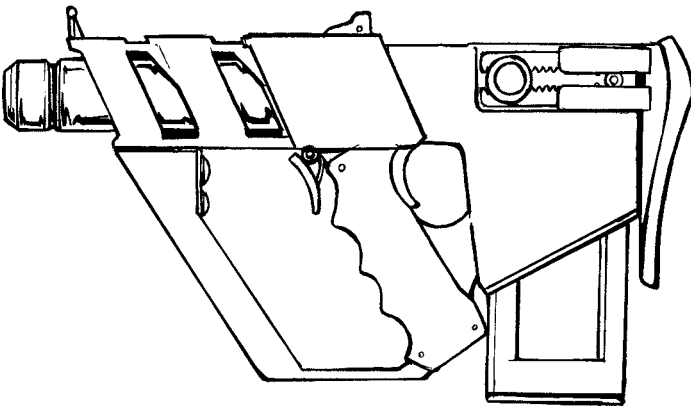

NG-SE17 Laser Carbine (new)

The SE17 Laser Carbine fulfills a similar role to the Burst Pistol in that it is a compact weapon good for boarding actions or stowage onboard a lifeboat. The Carbine has good range and uses energy more efficiently.

Weight: 9 lbs (4 kg).

Range: 1,500 feet (457 m).

Mega-Damage: 3D6 M.D.

Rate of Fire: Each shot counts as one melee attack.

Payload: 17 shots with a standard E-Clip or 28 with a long E-Clip.

Cost: 20,000 credits.

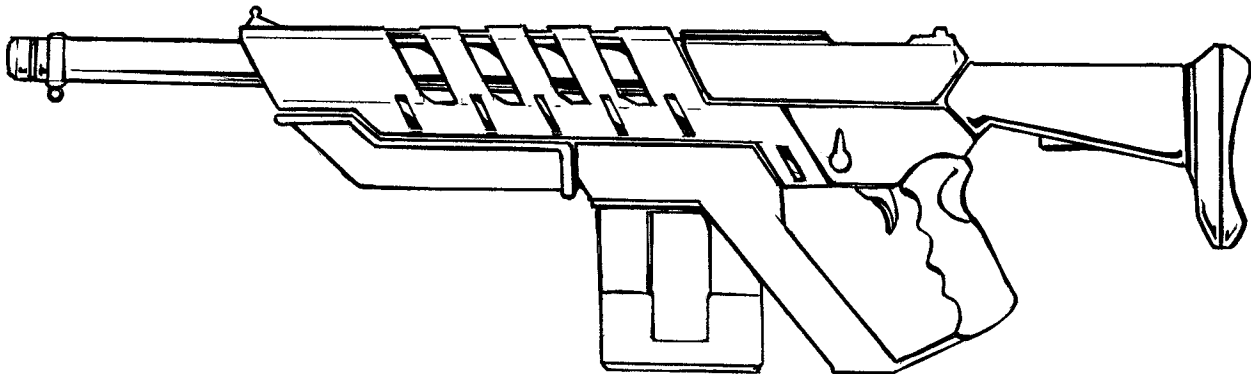

NG-SE20 Laser Rifle (new)

The Seasnake SE20 is the heaviest weapon in the Seasnake family. It is a true battle rifle with full underwater capabilities. It has the lighter design of most Seasnake weapons, but is still sturdy enough to be used as a melee weapon. Marines like the weapon for its ability to fire into the water at incoming torpedoes, minisubs or sea monsters.

Weight: 12 lbs (5.4 kg).

Range: 1,800 feet (549 m).

Mega-Damage: 3D6+4 M.D.

Rate of Fire: Each shot counts as one melee attack.

Payload: 15 shots with a standard E-Clip or 25 with a long E-Clip.

Cost: 25,000 credits.

NG Solar Powered Lasers

In an effort to cater to Wilderness Scouts, downed pilots and its remote and impoverished customers, the Northern Gun design team led by **Thaddeus Moore, Anthony Casab** and **David A. Moffatt** have devised a new type of energy weapon that runs on solar-power. Each of these sunlight driven laser weapons has a solar panel "hood" that connects to a battery similar to an E-Clip. While the UV series have limited range, they can make the difference between life and death for someone stranded in the wilderness. Solar energy systems are new to Northern Gun and most people consider it pioneering, experimental technology.

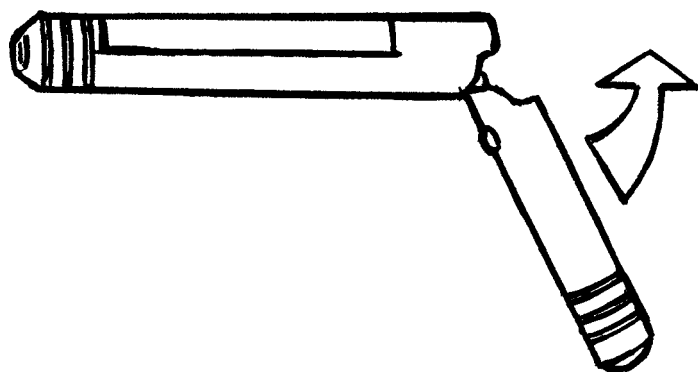
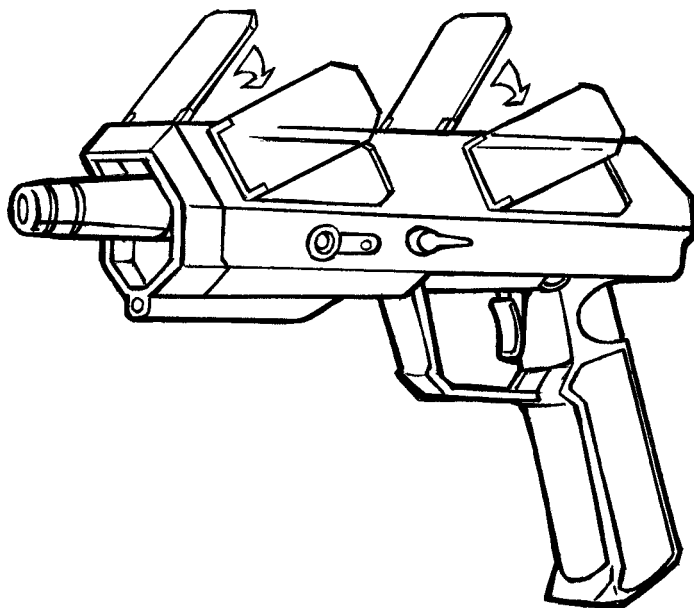

NG-UV1 Solar Powered Mini-Laser

The UV1 is a small pistol made for convenient storage and concealment. The solar panel flips up for better absorption of sunlight, and the handgrip can be folded back to essentially make the gun into one long tube, even easier to store, handle and conceal, but -1 to strike.

Weight: 0.8 lbs (0.36 kg).

Range: 300 feet (91.5 m).

Mega-Damage: 1D6 M.D.

Rate of Fire: Each shot counts as one melee attack.

Payload: 12 total solar charges. One shot per charge. Takes two hours of direct sunlight to recharge one blast. Diffused sunlight (overcast sky) will not charge the weapon. Can also use standard E-Clips (22 blasts).

Cost: 12,000 credits.

NG-UV4 Solar Powered Laser Pistol

The UV4 is a full-sized pistol with greater power, range and payload, but is a fairly bulky pistol with the solar panel hood taken into consideration.

Weight: 3.8 lbs (1.7 kg).

Range: 600 feet (183 m).

Mega-Damage: 2D4+1 M.D.

Rate of Fire: Each shot counts as one melee attack.

Payload: 16 total solar charges. One shot per charge. Takes three hours of direct sunlight to recharge each shot. Diffused sunlight (overcast sky) will not charge the weapon. Can also use standard E-Clips (20 blasts).

Cost: 20,000 credits.

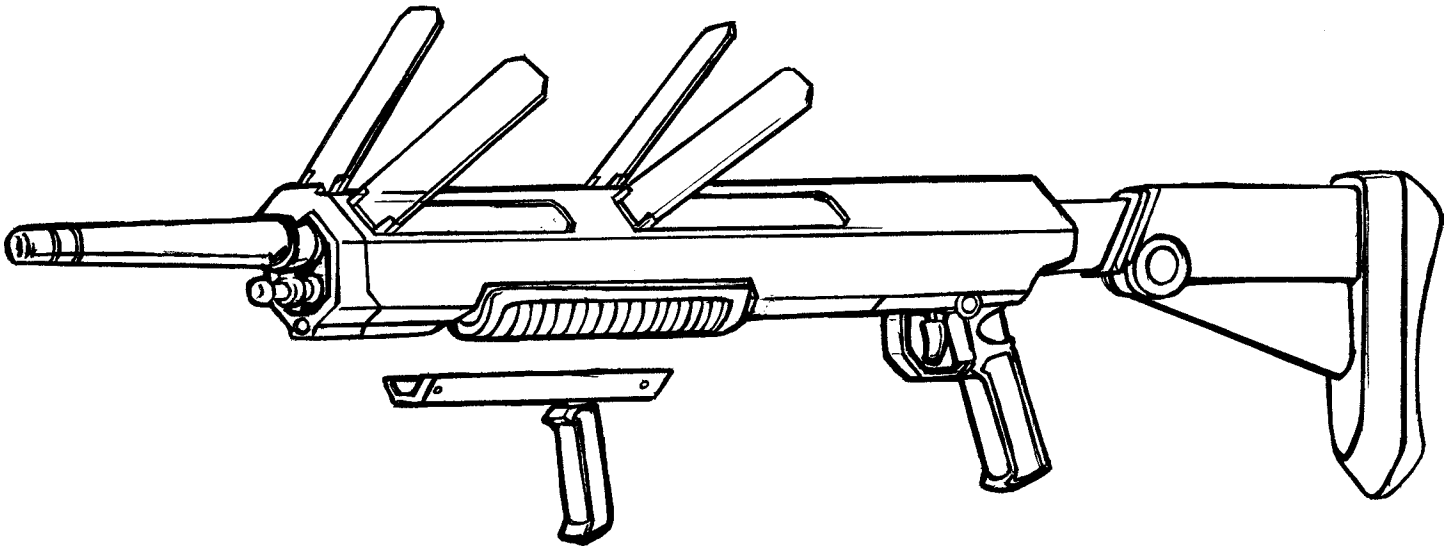

NG-UV7 Solar Powered Laser Rifle

For serious survivors and wilderness folk, the UV7 laser rifle is a much more capable weapon that still harnesses energy directly from the sun. Its solar panel section is clipped to the top of the gun but can be disconnected and placed on the shooter's shoulder or back, connected to the rifle's battery by an extendable M.D. cord.

Weight: 7.5 lbs (3.4 kg).

Range: 1,200 feet (366 m).

Mega-Damage: 2D6 M.D.

Rate of Fire: Each shot counts as one melee attack.

Payload: 18 total solar charges. One shot per charge. Takes four hours of direct sunlight to recharge each shot. Can also use standard E-Clips (20 blasts).

Cost: 30,000 credits.

Heavy Energy Weapons

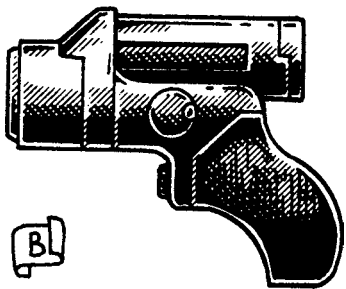

NG-H5 Holdout Ion Pistol

Once restricted to Northern Gun personnel and IMCN mercs, the H5 Holdout pistol is small and deadly, designed to fit in pockets (+6% to concealment rolls) and pass right through metal detectors. Normal metal detectors have no chance of picking up on the weapon's ceramic construction, which many argue was 'inspired' by similar Wilk's products. High quality detection systems have a 01-40% chance of registering the gun, but these kind of setups are usually only found within the Coalition States, Northern Gun and other centers of technology.

The Holdout is extremely popular, even though it has been outlawed within the CS, Free Quebec and several other states. While customers had to settle for knock-offs and occasional hijacked shipments in the past, demand for the little weapon has led to open sales from Northern Gun, who market the Holdout as a survival and backup gun for Bush Pilots, law enforcement, Wilderness Scouts, spies and assassins. Of course, as an easy to conceal weapon, it is popular among all manner of criminals,

spies, hit men and Black Marketeers. The design team leaders responsible for this little gem is **Brandon Fong** and **Chris Miller**.

Weight: Under one pound (0.45 kg).

Range: 200 feet (61 m).

Mega-Damage: 1D4+1 M.D. per shot.

Rate of Fire: Each shot counts as one melee attack.

Payload: 6 shots.

Cost: 50,000 credits due to the miniaturization and ease of concealment. However, NG has recently reduced the price to 35,000 credits (109 P.A.) and often makes it a sale item for as little as 30,000 credits.

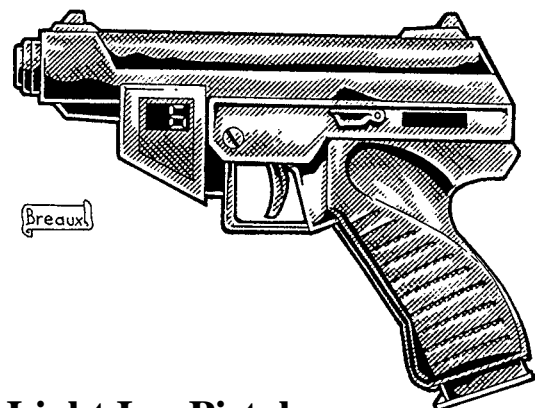

NG-56 Light Ion Pistol

One of the older side arms offered by Northern Gun, the NG-56 is lighter and more powerful than previous pistols, though it burns through E-Clips at an accelerated rate.

Weight: Block I: 3 lbs (1.4 kg). Block II: 2.5 lbs (1.1 kg).
Range: 400 feet (122 m).
Mega-Damage: 2D6 M.D.
Rate of Fire: Each shot counts as one melee attack.
Payload: 6 shots per standard E-Clip, 12 shots per long E-clip, or 42 shots with Power Pack (pack weighs 3 lbs/1.4 kg and recharges 4 blasts per hour; costs 60,000 credits).
Cost: The list price is 10,000 credits, but this old standard pistol has been on sale at 5,000 credits so often over the years, that most people think of it as the list price.

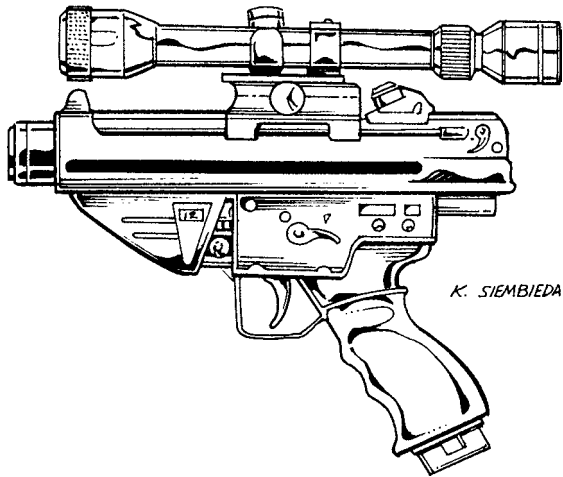

NG-57 Heavy-Duty Ion Blaster

Another Northern Gun classic that came out around the same time as the NG-Super Laser Pistol, the NG-57 is a heavy-duty ion blaster that has as much power as many rifles and better energy conservation – all contained in a weapon that fits snugly in a hip holster or glove compartment.

Weight: 5 lbs (2.25 kg).
Range: 500 feet (152 m).
Mega-Damage: Two settings, 2D4 or 3D6 M.D.
Rate of Fire: Each shot counts as one melee attack.
Payload: 10 shots.

Cost: This long-time favorite that is almost always on sale for 8,000 credits, even though its ‘official’ list price is 15,000 credits. Knock-offs are also available from the Black Market for 8,000 credits.

NG-59 Ion Pistol & Grenade Launcher (new)

The new NG-59 Ion Pistol developed by team leaders **Oswin Chang** and **James Holt** is a variant of the NG-56. It incorporates a light ion blaster with a single-shot grenade launcher into a compact pistol housing, providing an unexpected amount of firepower for such a small package. The 59 is popular amongst gang members, law enforcement (who often load the grenade launcher with smoke or tear gas) and soldiers who like a side arm with a certain element of surprise.

Weight: 3.5 lbs (1.6 kg).
Range: Laser: 400 feet (122 m). Grenade Launcher: 500 feet (152 m).
Mega-Damage: Ion: 2D6 M.D. Grenade Launcher: 2D6 M.D. to a blast area of six feet (1.8 m).

Rate of Fire: Each shot or grenade counts as one melee attack. Reloading the grenade launcher requires one melee action.
Payload: 20 shots per standard E-Clip, 30 shots long E-Clip. Grenade launcher holds one grenade.
Cost: 15,000 credits. Grenades cost 400 credits apiece or 3,800 a dozen and take two melee actions to reload. Can fire virtually any type of rifle grenade.

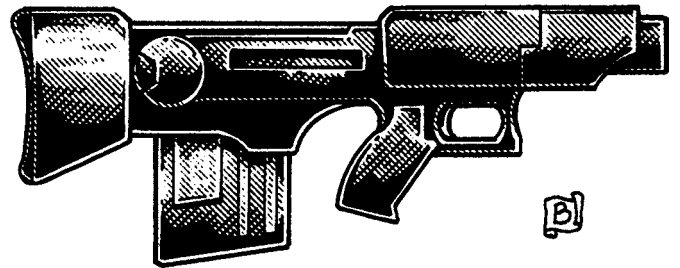

NG-IP7 Ion Pulse Rifle

A high-tech departure from Northern Gun’s usual style, and was conceived by team leaders **Frank Mitchell** and **David A. Hughes**. The IP7 ion pulse rifle is built with an E-Clip port in the rear of the gun, with a “bull-pup” configuration that makes it easy to wield in close quarters. Three-shot pulses deliver a huge amount of energy, but all that energy has to come from somewhere and the shooter would be wise to keep a good supply of E-Clips on hand.

Weight: 7 lbs (3.15 kg).
Range: 1,600 feet (488 m).
Mega-Damage: Single shot 3D6 M.D. or multiple pulse 1D4x10 M.D. (a pulse counts as one attack but consumes three shots).
Rate of Fire: Each single shot or pulse counts as one melee attack.
Payload: 30 single shots and 10 pulse blasts per special dual E-Clip holder (contains two E-Clips in one oversized housing; an idea that NG quickly gave up on) or 15 single shots and 5 pulse blasts per one standard E-Clip.
Cost: 20,000 credits.

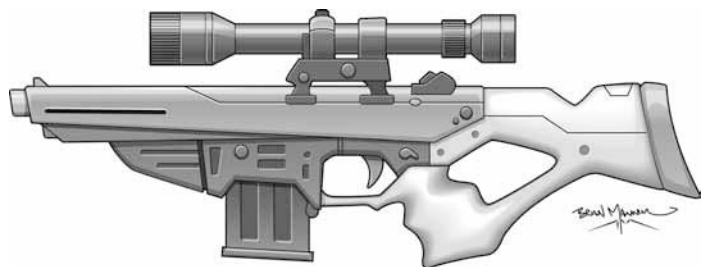

NG-IR5 Ion Rifle (new)

The NG-IR5 is a rifle version of the popular NG-57 Heavy-Duty Ion Blaster whipped up by **Scott Gibbons**, **Jason Williamson** and **Neil Johnson**. It has greater power along with much better range and energy management, but retains the dual damage settings and the ability to fire into and under the water. This last feature makes the IR5 popular with privateers and pirates, as well as raiders and ship crews working out on the Great Lakes who often have to fend off lake monsters.

Weight: 11 lbs (5 kg).
Range: 2,000 feet (610 m).
Mega-Damage: Two settings, 2D6 or 4D6 M.D.
Rate of Fire: Each shot counts as one melee attack.

Payload: 20 shots per standard E-Clip at the low setting, 11 shots at the higher setting. 36 and 15 shots with a long E-Clip.
Cost: 24,000 credits.

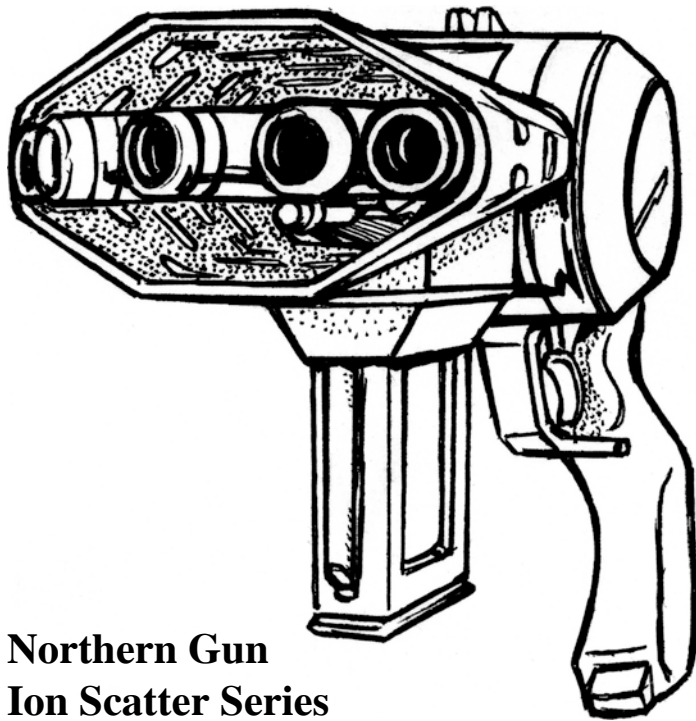

Northern Gun Ion Scatter Series

Drawing on NG's experience with ion weapons, the Ion Scatter Series uses multiple small, highly-efficient ion dischargers to spread its firepower across a horizontal plane. Unlike a conventional shotgun, which fires a circular pattern of pellets, the Ion Scatter weapons' horizontal fire patterns increase the odds of hitting targets at a specific height or orientation. Ion Scatter weapons are highly effective in trenches, enclosed buildings and streets and alleys. As their energy is more widely dispersed than traditional ion weapons, they have an extremely limited range. **Note:** Reduce range and damage by half underwater. The Ion Scatterguns come from the drawing boards of **Juan Baez, Steven Brewinton, Sean Reed** and **Andrew Gillespie**.

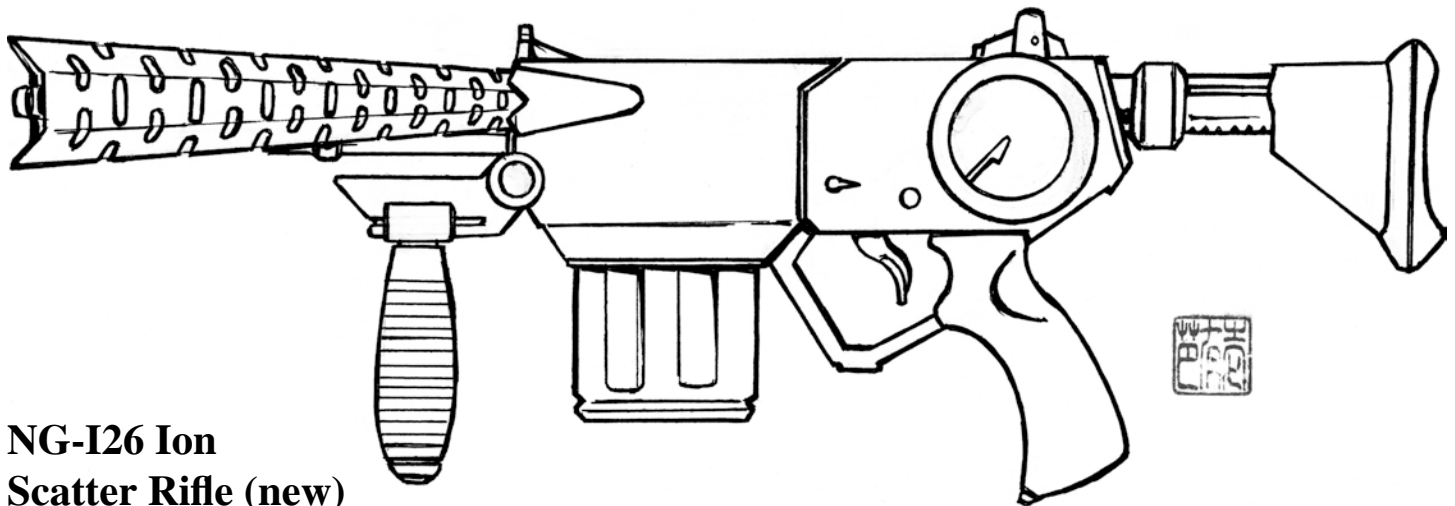

NG-I26 Ion Scatter Rifle (new)

The full-sized Ion Scatter Rifle is a true battlefield weapon and throws a wider spread of ion charges. The Scatter Rifle is well at home clearing out trenches, shooting into formations and providing suppressive fire against enemies who attack in waves like the Xiticix.

NG-I8 Light Ion Scattergun (new)

The "pistol" scattergun is actually more of a submachine-gun style weapon, fitting right in with Northern Gun's other large pistol designs. It has five barrels that each project their own discharge of ion energy. For indiscriminately clearing rooms and firing into crowds of attackers, the NG-I8 is powerful and easily managed.

Weight: 5 lbs (2.25 kg).

Range: 100 feet (30.5 m).

Mega-Damage: 1D6 M.D. to everyone within a 4 foot (1.2 m) radius of the intended target and not behind cover.

Rate of Fire: Each shot counts as one melee attack.

Payload: 10 shots per standard E-Clip, 18 shots with a long E-Clip.

Penalty: The awkward and heavy nose/barrel sections imposes a -2 to strike penalty even on aimed shots.

Cost: 25,000 credits.

NG-I13

Medium Ion Scattergun (new)

The NG-I13 is a more robust, shotgun version of the Ion Scattergun concept. It has greater range and power, but works just like the lighter pistol variant. It has two E-Clips to power it. One near the trigger and another in the right side of the weapon.

Weight: 9 lbs (4 kg).

Range: 200 feet (61 m).

Mega-Damage: 2D6 M.D. to everyone within a 4 foot (1.2 m) radius of the intended target and not behind cover.

Rate of Fire: Each shot counts as one melee attack.

Payload: 10 shots per two standard E-Clips, 18 shots with two long E-Clips.

Penalty: The awkward and heavy nose/barrel sections imposes a -1 to strike penalty even on aimed shots and even with a forward grip.

Cost: 35,000 credits.

Payload: 9 shots per two standard E-Clips, 16 shots with two long E-Clips.

Penalty: The awkward and heavy nose/barrel sections imposes a -2 to strike penalty even on aimed shots.

Cost: 45,000 credits.

NG-PB713 Particle Beam Pistol (new)

Particle beam weaponry is something of an exclusive area of technology for Northern Gun. The company had given up on particle beam weapons because of stability concerns and high energy consumption issues. Over the last few years, however, NG has gone back to the drawing board to produce a handful of new P-beam weapons. The design leaders, **Neal Johnson**, **Damon Armstrong**, **Seth Lamble** and **Joseph MacIsaac** and their team, have managed to put a particle beam in a weapon small enough to be considered a pistol. Shrinking the P-beam tech down to the size of a pistol was a tremendous challenge, but it is NG's hottest selling new handgun.

Weight: 6 lbs (2.7 kg).

Range: 300 feet (91.5 m).

Mega-Damage: 5D6 M.D. per blast and a Critical Strike does 50% more damage on the roll of a Natural 19 or 20. Vampires, Werebeasts and mummies are impervious.

Rate of Fire: Single shot only. Each shot counts as a melee attack.

Payload: 10 shots from a standard short E-Clip, 16 with a long E-Clip.

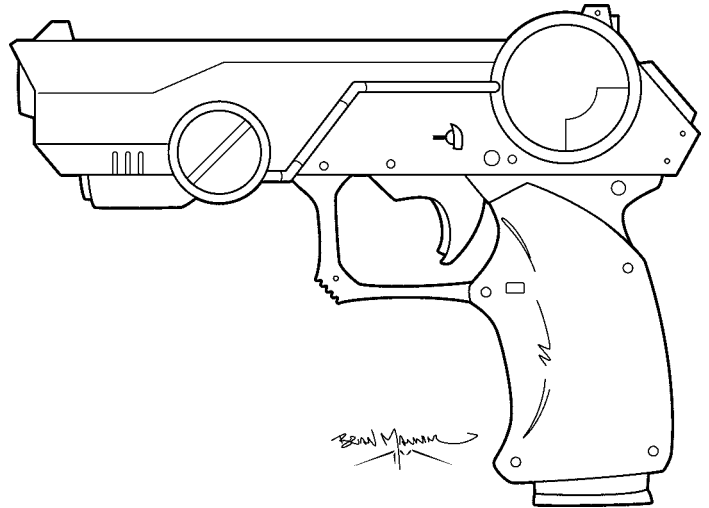

Cost: 40,000 credits (double to triple outside of Northern Gun, even at NG stores away from Upper Michigan). Poor availability due to overwhelming demand for this small, very lethal weapon.



NG-P5 Light Particle Beam Rifle (new)

The NG-P5 is a more manageable, modern weapon based off the older NG-P7 heavy particle beam rifle and the NG-45LP pistol. It was developed by team leaders **Benjamin Mason**, **Charles Huighe** and **Jacob Healy**. It still provides substantial firepower in a single shot function, but is lighter and has better ammunition capacity.

Weight: 14 lbs (6.3 kg).

Range: 1,200 feet (365 m).

Mega-Damage: 5D6 M.D., a Critical Strike does 50% more damage on the roll of a Natural 19 or 20. Vampires, Werebeasts and mummies are impervious.

Rate of Fire: Single shot only. Each shot counts as a melee attack.

Payload: 10 shots from a standard short E-Clip, 16 with a long E-Clip.

Cost: 28,000 credits.

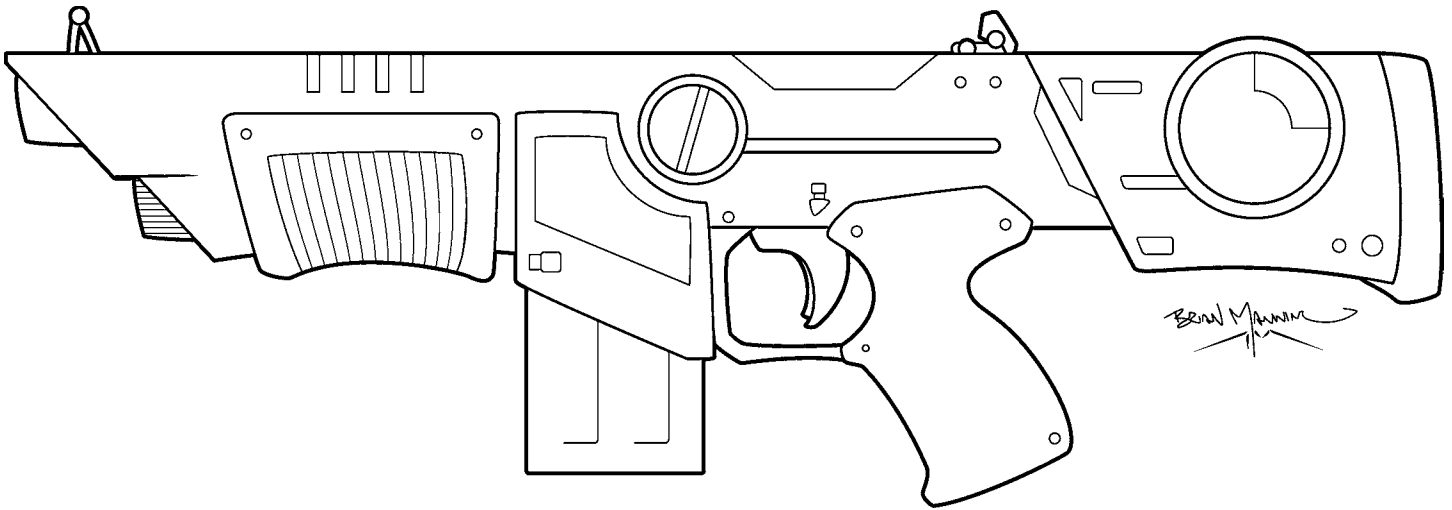

NG-P7 Particle Beam Rifle

Northern Gun's reputation for heavy, practically unbreakable weapons was built on guns like the P7 designed by K.H.S. While the original Block I version weighed in at a sturdy twenty-one pounds (9.45 kg), the newest Block III particle beam rifles have almost cut that weight in half, much to the relief of anyone that has to carry one out on patrol.

Weight: Block I: 21 lbs (9.45 kg). Block II: 17 lbs (7.6 kg). Block III: 12 lbs (5.4 kg).

Range: 1,200 feet (365 m).

Mega-Damage: 1D4x10 M.D. per blast, a Critical Strike does 50% more damage on the roll of a Natural 19 or 20. Vampires, Werebeasts and mummies are impervious.

Rate of Fire: Each shot counts as one melee attack.

Payload: 8 shots from a standard E-Clip or 12 with a long E-Clip.

Cost: 22,000 credits.

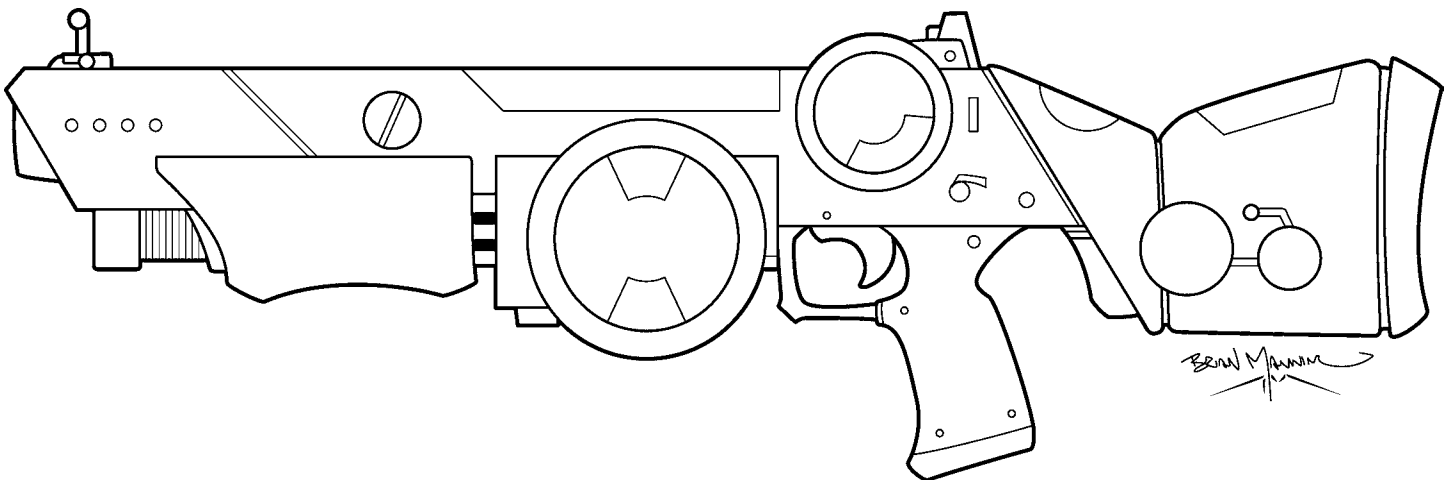

NG-P9 Heavy Particle Beam Rifle (new)

The P-9 particle beam rifle is the big brother of Northern Gun's P-5 and P-7 particle beam rifles. While a good weapon, the P-9 is generally outshone by similar weapons made by the Coalition States, Naruni Enterprises, Triax and Northern Gun.

Weight: 12 lbs (5.4 kg).

Range: 1,600 feet (488 m).

Mega-Damage: 1D4x10 M.D. per blast, a Critical Strike does 50% more damage on the roll of a Natural 19 or 20. Vampires, Werebeasts and mummies are impervious.

Rate of Fire: Single shot only. Each shot counts as a melee attack.

Payload: 6 shots from a standard E-Clip or 9 shots with a long E-Clip.

Bonus: Laser targeting standard; +1 to strike on aimed shots.

Cost: 45,000 credits. Double to triple outside of Northern Gun, even at NG stores away from Upper Michigan. Poor availability due to high demand for this lethal weapon.

NG-P85 Personal Particle Beam Cannon (new)

This heavy weapon has a slightly longer range than rifles, and packs a bit of a bigger punch. Taking a page from the Glitter Boy play book, this big gun is a shoulder-mounted and firing particle beam cannon designed for Combat Cyborgs and power armor to provide them anti-armor firepower, if only for a moment. The PBC drains E-Clips quickly, and is most often sold along with a support weapon-sized power pack (30 blasts per power pack).

Weight: 61 lbs (27.5 kg).

Range: 1,800 feet (549 m).

Mega-Damage: 1D4x10+4 M.D. per blast, a Critical Strike does 50% more damage on the roll of a Natural 19 or 20. Vampires, Werebeasts and mummies are impervious.

Rate of Fire: Each shot counts as one melee attack.

Payload: 4 shots per short E-Clip, 7 for a long E-Clip. 30 blasts with an NG power pack.

Penalties: -1 to dodge and reduce the running speed by 10% and the flying speed of power armor or cyborgs with jet packs by 20% whenever this large, shoulder mounted weapon system is attached. Requires the W.P. Heavy Weapons skills for bonuses to strike. All penalties are cumulative.

Connecting the weapon directly into to the Combat Cyborg or power armor's own nuclear energy supply reduces its running/flying speed by an additional 10% and apply the following penalties: -1 to dodge, -1 attack per melee round, due to weight, awkwardness of movement, and slow response from other built-in systems. Moreover, the weapon mounted on the shoulder makes the 'Borg or power armor top heavy on one side, making movement clumsy and less fluid.

Cost: 75,000 credits and includes the apparatus for attaching it to the back and shoulders. Hangs over one shoulder or the other. Not suitable for all power armors or cyborgs, and only one can be attached at a time.

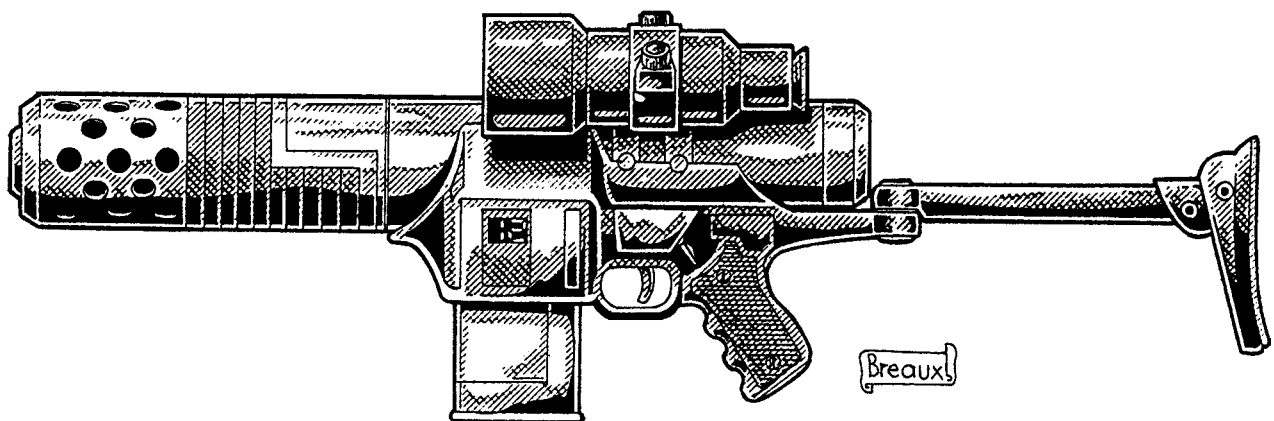
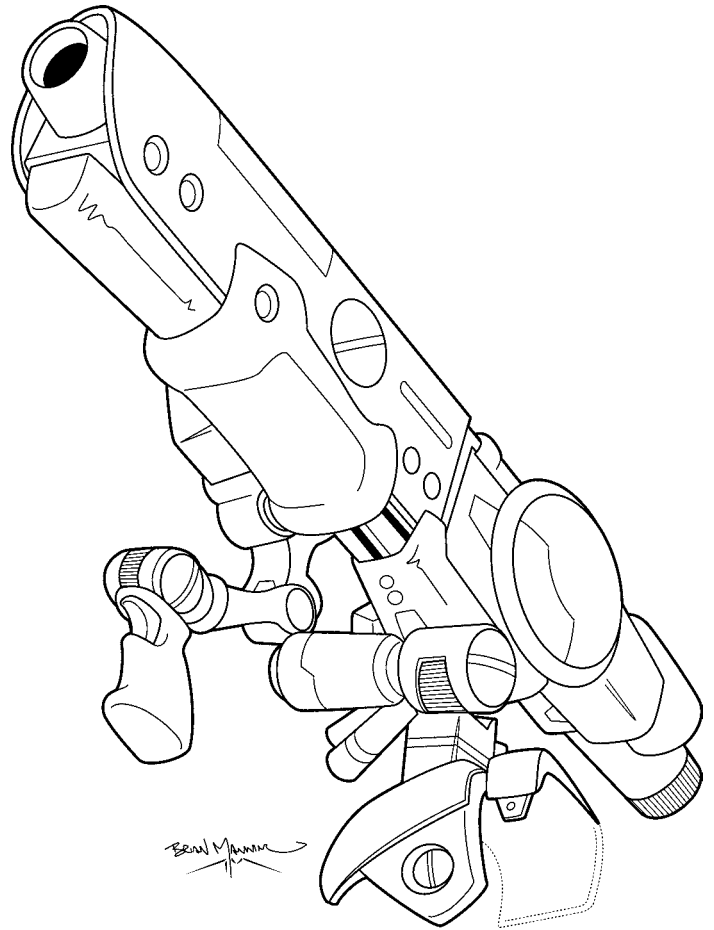

NG-E4 Plasma Ejector

The brutal damage and short range of plasma weapons suits the philosophy of Northern Gun well. The E4, conceived by team leaders **Frank Loose** and **Nathan Jacobus**, is a man-portable rifle perfect for toasting anything that gets in its sights. The fact that its internal mechanisms bear a suspicious resemblance to the Coalition's old C-27 Plasma Cannon is a fact NG would rather not draw attention to.

Weight: Block I: 20 lbs (9 kg). Block II: 16 lbs (7.2 kg).

Range: 1,600 feet (488 m).

Mega-Damage: 6D6 M.D.

Rate of Fire: Each shot counts as one melee attack.

Payload: 10 shots standard E-Clip or 20 shots for a long E-Clip.

Cost: 30,000 credits.

NG-E12 Heavy Plasma Ejector

An enlarged version of the E4 Plasma Ejector, devised by **Nathaniel Baker** and **Ben Bingham**, the E12 is intended for emplacements and vehicles. There is also a rifle version that is being included with more and more Northern Gun power armor and robot packages and is popular with cyborgs, but is simply too heavy and bulky for unaugmented humans.

Weight: 30 lbs (12.5 kg) using an E-Clip, 50 lbs (22.5 kg) with a power pack.

Range: 2,000 feet (610 m).

Mega-Damage: 1D6x10 M.D.

Rate of Fire: Each shot counts as one melee attack.

Payload: 6 shots standard clip, 12 shots long E-Clip, or 42 shots with Power Pack (pack weighs 20 lbs/9 kg and regenerates 4 blasts per hour; costs 80,000 credits).

Cost: 80,000 credits.

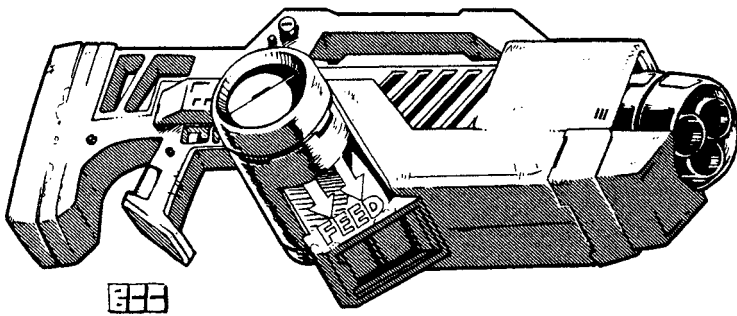

NG-E15 Pulse Plasma Ejector

Arguably a product of Northern Gun's engineers getting carried away with themselves, the Pulse Plasma Ejector is the finest creation of the science team the Trade Council tasked with developing plasma weapons. Led by team leaders **Paul Herbert** and **Mel Primus**, the E15 was devised with augmented humans and powerful D-Bees in mind. Though it is impractically heavy for normal humans, it gives Combat Cyborgs, Crazies, power armor troopers, Juicers and the like, a chance against the bigger and more dangerous monsters and military adversaries out there. Including the Power Pack necessary for anyone who wants to fire the weapon consistently in burst mode, a soldier with an E15 is toting approximately 70 lbs (31.5 kg) of firepower, too much for normal infantry with any additional gear, but not a problem for augmented troops and strong D-Bees.

Weight: 50 lbs (22.5 kg) plus an additional 20 lbs (9 kg) for the Power Pack which can be carried in a hip-pack or backpack.

Range: 1,600 feet (488 m).

Mega-Damage: 5D6 per single shot or 2D4x10 per triple pulse burst.

Rate of Fire: Each single blast or triple pulse counts as one melee attack.

Payload: The Power Pack provides enough power for 48 single shots or 16 triple pulse blasts. A long E-Clip has enough power for 12 single shots or 4 pulse shots and a standard E-Clip has enough for 6 single shots or two pulse blasts.

Penalty to Strike: -2 for anyone, even those with Supernatural, Robot or Bionic P.S. or a human P.S. of 25 or greater. -7 to strike for characters with less strength. -1 to strike even when mounted on a tripod or vehicle.

Cost: 62,000 credits for the weapon. The Power Pack costs 30,000 credits and can be recharged at a cost of 10,000 credits up to 20 times before needing to be replaced.

Rail Guns & Non-Energy Weapons

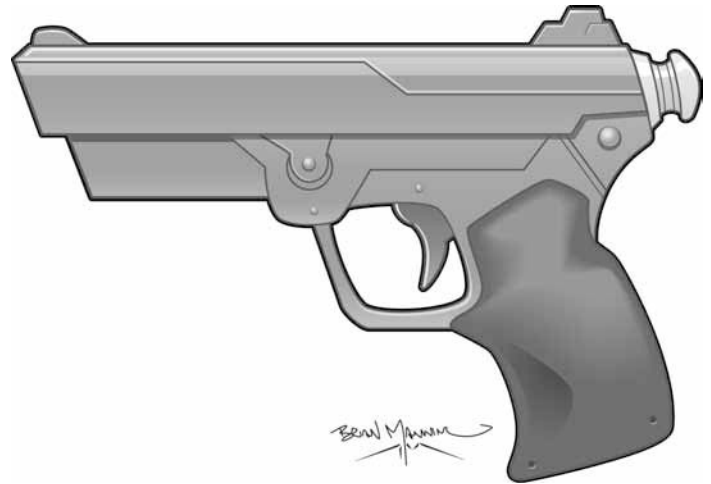

NG-T9 Dart Tranquilizer Pistol (new)

A tranquilizer pistol can be used for subduing ordinary animals for capture and treatment, as well as to knockout people (mainly humans), without hurting them. The weapon is most popular among naturalists, explorers and scientists exploring the wild, as well as spies, thieves, smugglers, and those who engage in industrial espionage. Using a tranq gun enables them to subdue guards and personnel without using lethal force. Moreover, such criminals and espionage operatives usually use snatch and grab tactics and avoid being seen or fighting with guards. This means getting in fast and quietly – hopefully unseen – grabbing what they came for, and getting out even faster (and hopefully unseen).

Weight: 3 pounds (1.35 kg).

Range: 90 feet (27.4 m).

Damage: Tranquilizer darts render susceptible victims unconscious for 1D4+1 melee rounds and leaves them groggy for a while after. The drug takes effect within five seconds.

Saving Throw: *Humans:* 16 or higher to save vs non-lethal poison.

D-Bees: 12 or high to save from the same drug, and when it does work, the duration and penalties are half on nonhumans. **Note:** Has *NO effect* on supernatural beings, not even lesser beings like sub-demons, nor does it work on creatures of magic and Mega-Damage D-Bees (the dart bounces right off their M.D.C. hide). Obviously the dart cannot penetrate even S.D.C. armor.

Failure to save temporarily renders the victim unconscious as described under Duration.

Those who save vs non-lethal poison suffer grogginess for one melee round (15 seconds) before returning to full awareness and capabilities.

Penalties for Grogginess: Reduce all combat bonuses and Spd by half, no initiative and no Perception Roll bonuses whatsoever, -1 one melee attack, and -15% on skill performance.

Duration: Knocked out for 1D4+1 melee rounds. Groggy for 1D6+2 additional melee rounds after waking up. However, if the

victim is attacked or fears for his life, the adrenaline rush reduces the duration by half.

Rate of Fire: Single shot.

Payload: One dart.

Penalty to Strike: -1 to strike even with W.P. Pistol or Revolver.

Cost: 6,500 credits for the pistol. Darts are 800 credits each. Very poor availability for the gun and darts outside Ishpeming.

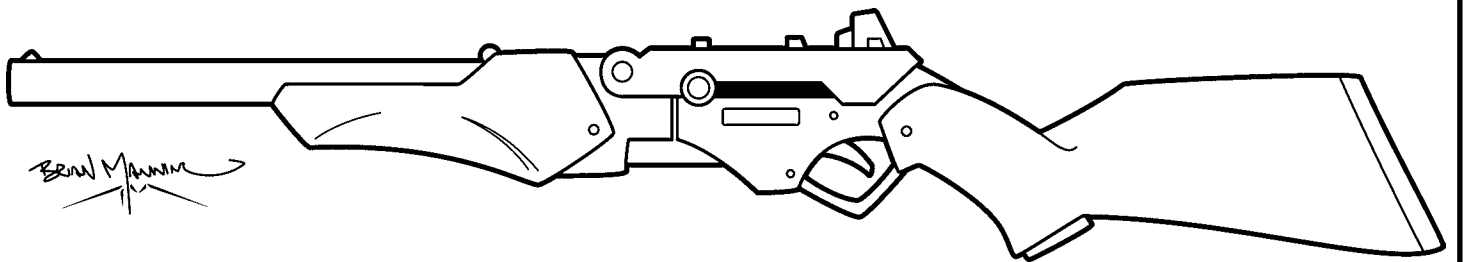

NG-T12 Tranquilizer Rifle (new)

This is a rifle designed to fire a tranquilizer dart. Its effective range is much less than a normal rifle and the weapon must be hand-loaded after every two shots (counts as two melee actions to reload on dart, four to reload two darts). Victims must save vs toxin or be knocked unconscious as described under the description for the pistol.

Weight: 6 pounds (2.70 kg).

Range: 800 feet (244 m).

Damage: Same as the pistol, above.

Saving Throw: Same as the pistol, above.

Penalties for Grogginess: Same as the pistol, above.

Duration: Same as the pistol, above.

Rate of Fire: Single shot.

Payload: Two darts.

Penalty to Strike: -1 even with W.P. Rifle.

Cost: 14,500 credits for the rifle. Darts are 900 credits each. Very poor availability for the gun and darts outside Ishpeming.

NG-MC1 Mega-Crossbow

A Mega-Damage throwback to the Middle Ages, the NG-MC1 is a high-powered crossbow made for silent kills, fighting vampires, and launching 'alternative projectiles.' With its powerful firing mechanisms a P.S. of at least 26 is required to cock the weapon, (Supernatural/Robot P.S. of 17 or Bionic/Augmented P.S. of 20) but normal users can fire it without difficulty. A winch lets anyone without bulging biceps reset the firing mechanism, but even the newer, improved design requires 1D4 melee attacks/actions to reload.

Standard crossbow bolts are available, as well as bolts with armor-piercing M.D. cores. The crossbow can fire wooden or silver ammo, and NG also sells flare, smoke, tracker bug and explosive-tipped bolts. Conceived and developed by the design team under **Colin McBride** and **Jason Martin**.

Weight: 10 lbs (4.5 kg) for the crossbow; Mega-Damage bolts weigh eight ounces (0.22 kg) to 1.5 lbs (0.7 kg) each.

M.D.C. of the Crossbow: 8 M.D.C.

Range: 1,200 feet (366 m). This weapon can fire as far as 1,500 feet (457 m), but accuracy beyond 1,200 feet (366 m) drops (-3 to strike).

Mega-Damage: *Ordinary S.D.C. bolts*, including wooden bolts for fighting vampires, inflict 2D6+2 S.D.C. and may shatter on impact, especially when directed at M.D.C. targets (no damage).

S.D.C. wooden stake 3D6+1 S.D.C. (double damage to vampires), but range is only 600 feet (183 m).

Crossbow bolts made of M.D.C. material (about three times thicker than normal arrows) inflict 1D6 M.D. each.

High-tech speciality bolts with explosive heads do 2D6 M.D. or 3D6 M.D., and plasma arrowheads inflict 3D6 M.D. (double damage to beings vulnerable to fire/heat).

Smoke grenade arrows do no damage, but fill a 40 foot/12.2 m diameter area with smoke.

Flares are intended for signaling or illuminating an area, but inflict 3D6 S.D.C. damage when used as a weapon (-1 to strike).

Tracker bug bolts attach to the target with either a barbed point or magnets, and can be followed using a receiver handset that indicates direction with a 20 mile (32 km) range (2D6 S.D.C. as a weapon).

Rate of Fire: Special. It takes one melee attack/action to cock the weapon by individuals with a Supernatural, Robotic or Bionic P.S., or a human P.S. of 26 or higher. Those of lesser P.S. need a special pulley system to cock the weapon, and it uses up 1D4 melee attacks of the character. Also see W.P. Archery. Skilled archers get an extra attack and can fire rapidly.

Payload: Up to six bolts can clip onto the crossbow itself. Quivers and carrying cases typically hold 12, 24 or 32 crossbow bolts.

Bonus to Strike: +1 to strike on an aimed shot when a telescopic sight is attached to the crossbow.

Cost: 15,000 credits for the bow. S.D.C. bolts cost 5-8 credits each. Basic M.D.C. bolts cost 100 credits each and modern, specially explosive arrows cost 400 (2D6 M.D.), 800 (3D6 M.D.), and 120 credits for flare/tracer and smoke bolts. Tracker bug bolts cost 1,000 credits each, receiver handsets are 2,000 credits.

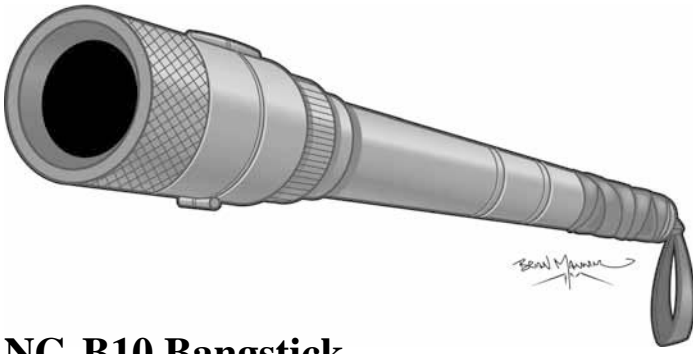

NG-B10 Bangstick

Bangsticks are extremely simple devices whipped up by two weapon engineers by the name of **James Kenagy** and **Victor Peterson**. Bangsticks are basically a short, simple, Mega-Damage rod with an *M.D. shotgun shell* at the end of a metal tube, they are designed so that the shotgun shell goes off at the point of impact, exploding against the target when it is jabbed with the rod. The normal rod version started out as a survival tool and simple weapon used by farmers, merchants and NG City Rats. However, it quickly became popular among City Rats everywhere, as well as gangbangers, brawlers and petty criminals as concealed weapons.

The typical Bangstick is 2-3 feet (0.6-0.9 m) long, and is easy to hide in a backpack, sack, briefcase, under a coat, cape or cloak, up a sleeve, down a pant leg, in a bundle, and so on. Some are even disguised as walking sticks or a cane. When the weapon has been fired, it can still be used as a bludgeon just like a metal pipe. After the first explosive strike, the Bangstick must be reloaded, by hand, to fire an M.D. shotgun round, but since the “stick” is made of M.D.C. material (Mega-Damage ceramic, plastic or scrap metal), it can be used to parry M.D. melee weapons such as Vibro-Blades and magic swords.

For reasons nobody is quite certain about, Bangsticks and Bangstick Hammers and Staves have become incredibly popular amongst Juicers, Crazies, Headhunters/partial cyborgs, gamblers and assassins. It may be the simplicity and visceral thrill of using such a simple device to slay an opponent that makes the stick attractive to these individuals. Or perhaps they enjoy the martial skill required to use them to their maximum potential.

Weight: 4 pounds (1.8 kg).

Range: Close combat/impact.

Mega-Damage: Functions as a blunt S.D.C. weapon with normal P.S.: 2D6 S.D.C. +P.S. bonus (if any). Blunt M.D. Weapon: 1D4 M.D. +P.S. M.D. punch damage if the user has a P.S. capable of inflicting M.D.

Shotgun Blasts: 2D4 M.D. impact damage for Mega-Damage explosive shells, 4D6 S.D.C. for buckshot, and 5D6 S.D.C. for solid slug. This is in addition to his usual P.S. punch damage. **Note:** Each successful shotgun blast causes full M.D. shotgun damage to the target. The round is fired from the end of the Bangstick, so to shoot, it must be “jabbed,” pointed end first, into the intended target.

Payload: A single shotgun shell (any type, S.D.C. or M.D.). Must be loaded by hand.

Cost: 800-1,200 credits for the standard Bangsticks, double for ornate walking sticks, canes or scepters. Also see Bangstick Hammers and Staves. Four standard M.D. shotgun shells come with each Bangstick sold by NG. M.D. shotgun shells costs 1,200 credits for a box of twenty or 100 credits each when buying smaller numbers.

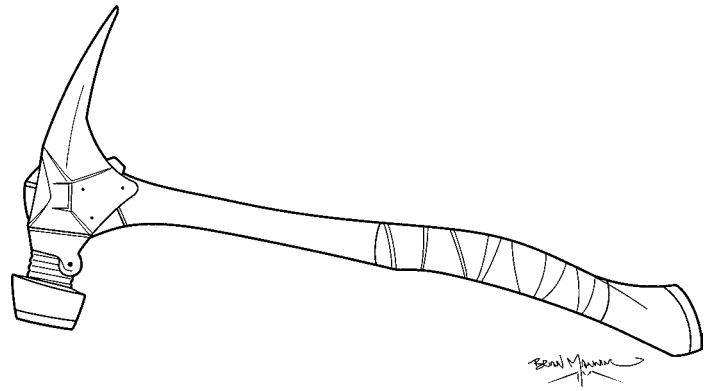

NG-B20 Bangstick Hammer

Bangstick Hammers work on a similar principle as the simple Bangstick. It was designed by NG weapons engineers **Jacob Postlewaite** and **Joseph Olewnicki** to function as an old-fashion war hammer with a modern bang. The handle is 2-4 feet (0.9-1.2 m) long so it can be used by horsemen, hovercycle pilots, flying power armor units, and those with a jet pack. The weapon ends in an M.D.C. hammer head to bludgeon an opponent. Some have a spike or claw on the other end of the head for combat and utilitarian purposes. A claw end, for example, can be used to pry open doors and windows, assist in climbing or hook an opponent’s wrist, weapon or ankle. Depending on the size of the hammer’s head, two or three M.D. shotgun rounds are contained in the flat portion of the head, which all go off simultaneously on impact. The weapon is most popular amongst Juicers, Crazies, Brodkil, other intelligent monsters and horsemen and flyers, but some adventurers are starting to take a look at Bangsticks and Bangstick Hammers and Staves.

Weight: 8 pounds (3.6 kg).

Range: Close combat/impact.

Mega-Damage: Functions as a blunt S.D.C. weapon with normal P.S.: 2D6 S.D.C. +P.S. bonus (if any). Blunt M.D. Weapon: 1D6 M.D. +P.S. M.D. punch damage if the user has a P.S. capable of inflicting M.D.

Two-round Hammer: 4D4 M.D. impact damage for Mega-Damage explosive shells. 1D4x10 S.D.C. for buckshot, 1D6x10 S.D.C. for solid slug.

Three-round Hammer: 4D6 M.D. impact damage for Mega-Damage explosive shells. 1D6x10 S.D.C. for buckshot, 2D4x10 S.D.C. for solid slug.

Payload: 2-3 shotgun shells (any type, S.D.C. or M.D.). 1,500-2,000 credits for the 2-shot Bangstick Hammers.

Cost: 1,500-2,000 credits for the 2-shot Bangstick Hammers. 2,500-3,000 credits for the 3-shot Bangstick Hammer. Double the cost if the weapon is ornate or has a single-shot firing apparatus in the base of the handle. Eight standard M.D. shotgun shells come with each NG Bangstick Hammer. M.D. shotgun shells cost 1,500 credits for a box of twenty. Must be loaded by hand.

NG-B30 Bangstick Staff

Fundamentally, a long Bangstick, 5-8 feet (1.5 to 2.4 m) long, that has a firing apparatus in both ends of the staff. This weapon was whipped up by weapon designers **James Plowman** and **Kevin Dyval**. Jab with one and fire a shot, twirl the staff around or back-thrust jab to fire the other.

Weight: 6.5 pounds (2.9 kg).

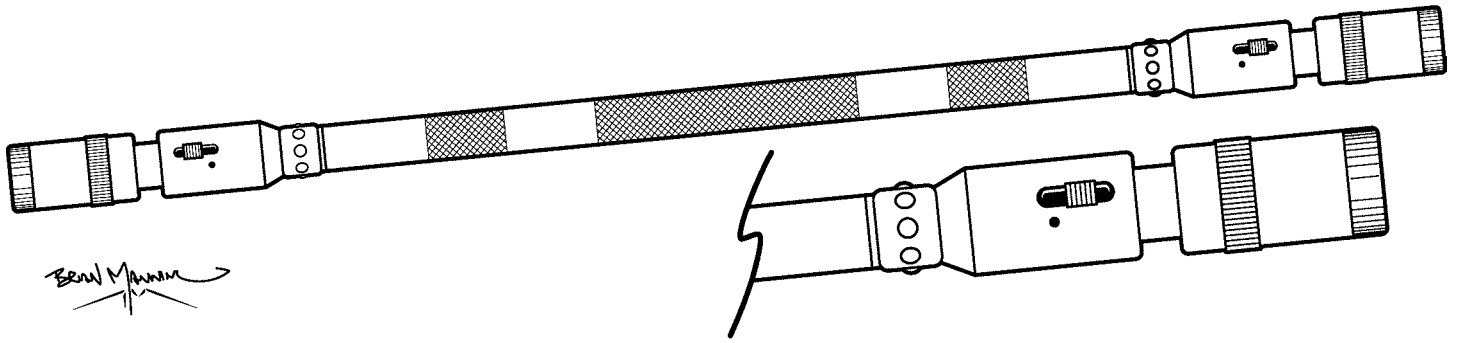

Range: Close combat/impact.

Mega-Damage: Functions as a blunt S.D.C. weapon with normal P.S.: 2D6 S.D.C. +P.S. bonus (if any).

Blunt M.D. Weapon: 1D6 M.D. +P.S. M.D. punch damage if the user has a P.S. capable of inflicting M.D.

2D4 M.D. impact damage for Mega-Damage explosive shells. 4D6 S.D.C. for buckshot, 5D6 S.D.C. for solid slug.

Payload: Two total. A single shotgun shell (any type, S.D.C. or M.D.) at each end of the staff. Must be loaded by hand; counts as two melee actions per each shell.

Cost: 1,500-3,000 credits for the standard Bangstick Staff; double for ornate staves. Also see other Bangsticks. Four standard M.D. shotgun shells comes with each NG Bangstick Staf. M.D. shotgun shells cost 1,200 credits for a box of twenty or 100 credits each when buying in smaller numbers.

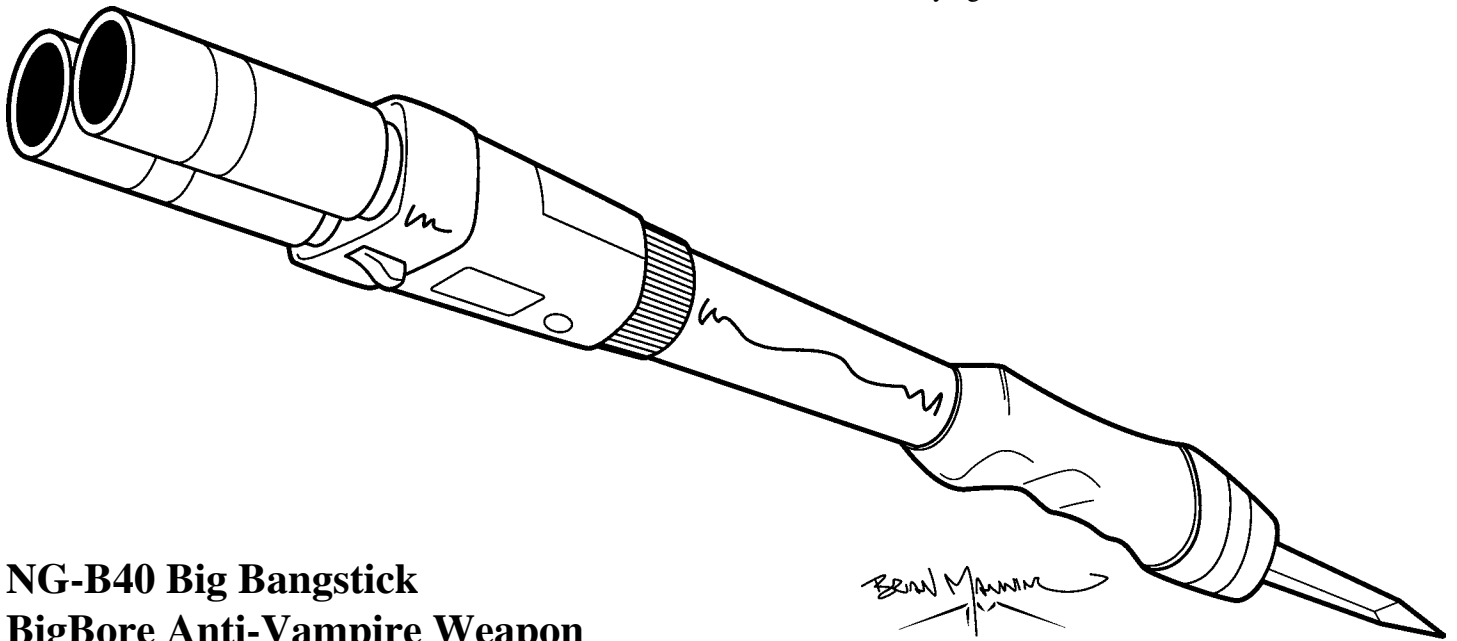

NG-B40 Big Bangstick BigBore Anti-Vampire Weapon

The “Big Bang Stick” is designed along the same lines as the other bangsticks with a few twists, and conceived by **Jacob Healy, Luis Martinez** and **C. Bellaire**.

First, it is a 3-4 foot (0.9 to 1.2 m) long metal rod that is thicker and heavier than most Bangsticks. The metal may be silver-coated and used as a bludgeon against vampires and Werebeasts for an extra cost of 10,000 credits.

Second, at the handle end there is a grip and a concealed, extendible/retractable, silver-coated knife blade (six inches/15 cm long).

Third, at the opposite end of the handle, the Big Bangstick looks more like a double-barrel shotgun. Indeed, it holds six, Black Market, *BigBore shotgun shells*. Each time a target is jabbed hard with the point of the double barrel of the cylinder, a BigBore shotgun shell goes off. In the alternative, BigBore shells may be replaced with conventional S.D.C. shells, or *wooden* or *silver shells* designed for fighting vampires. This is one of the few NG products that incorporates the ammo of a competitor.

In an emergency, the cylinder of the Big Bangstick can be fired manually, with the press of a trigger button, but has a very

short range of 20 feet (6.1 m). Even against the undead, the bang portion of the stick may be loaded with BigBore shells, since one of the shells can throw a vampire off its feet and allow the Vampire Hunter or a teammate time to rush in and stake the monster while it is knocked to the ground. BigBore rounds also allow the Big Bangstick to be used against other M.D.C. threats that may not have a particular weakness to wood or silver.

Weight: 11 lbs (5 kg); the weapon is 3-4 foot (0.9 to 1.2 m) long. Range: Melee Combat or 20 feet (6 m) for manual firing of shotgun feature.

Mega-Damage: Varies with ammo/weapon feature:

BigBore Shotgun Shells: 2D4 M.D. per single shell/bullet. See the BigBore Shotgun Shells in **Rifts® Black Market** for the knockdown effects of the BigBore shotgun shells.

Silver Rounds: Solid does 5D6 S.D.C.; double damage to vampires and werebeasts. Scatter shot fired at range does 2D6 S.D.C. to everything in a two foot (1.2 m) blast radius; double damage to vampires and werebeasts.

Wood Rounds: Solid, wood bullet does 2D6+2 S.D.C.; double damage to vampires. Scattershot of wood shards does 1D4 S.D.C.

to everything in a three foot (0.9 m) blast radius; double damage to vampires.

Silver-Coated Handle Blade: 1D6 S.D.C. damage; double to vampires and other beings vulnerable to silver.

Silver-Coated “Stick”/Barrel Used as a Bludgeon: 2D4 S.D.C. damage as a bludgeon; double to vampires or other beings vulnerable to silver.

Rate of Fire: Each “bang strike” or shot counts as one melee attack.

Penalties: -2 to strike as a ranged weapon.

Payload: Six shells; shotgun or BigBore.

Cost: 6,000-8,000 credits for the weapon. 120 credits per shell or 16,000 credits for a gross (box of 144 shells); 2-5 credits each for wooden, solid shot or scattershot S.D.C. rounds, 100-200 credits each for a silver coated solid shot, 400-600 for a solid silver slug or scattershot.

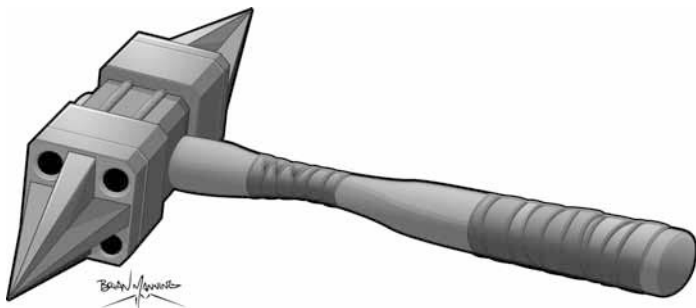

NG-B50 ‘Thunderer’ BigBore Combat Hammer

The NG team of **Stephen Schneider**, **Chad Trantham** and **C. Bellaire** have created the “Thunderer” combat hammer. A big, hefty weapon said to be ‘fit for the gods!’ The hammer is a massive two-handed affair that looks like it should be wielded by Thor himself. The head of the hammer has two facings, each being silver-coated, of course, for dealing with vampires and demons. Each facing is divided into nine sections like a tic-tac-toe board, with the center five squares being the Silver-plated Spike and the other four openings being the BigBore shotgun shell housings. When the Vibro-Spike impacts a target with killing force, 1D4 of the BigBore shells are also triggered, blasting the target at point-blank range. Once the target is killed or knocked off its feet, the wielder of the Thunderer usually follows up with another blow or backs away to get some breathing room. **Note:** The combat hammer has no ranged combat options, but conventional S.D.C. shotgun shells or special wood or silver shells may be substituted. Weight: 14 lbs (6.3 kg).

Range: Melee Combat only.

Mega-Damage: Functions as a blunt S.D.C. weapon with normal P.S.: 2D6 S.D.C. +P.S. damage bonus (if any); double damage to vampires. Blunt M.D. Weapon: 1D6 M.D. +P.S. M.D. punch damage if the user has a P.S. capable of inflicting M.D.

BigBore Shotgun Shells: 2D4 M.D. per single shell/bullet. See the BigBore Shotgun Shells in **Rifts® Black Market** for the knockdown effects of the BigBore shotgun shells.

Silver Rounds: Solid does 5D6 S.D.C.; double damage to vampires and werebeasts. Scattershot fired at range does 2D6 S.D.C. to everything in a two foot (0.6 m) blast radius; double damage to vampires and werebeasts.

Wood Rounds: Solid, wood bullet does 2D6+2 S.D.C.; double damage to vampires. Scattershot of wood shards does 1D4 S.D.C. to everything in a three foot (0.9 m) blast radius; double damage to vampires and werebeasts.

Rate of Fire: 1D4. Roll 1D4 to determine how many go off with each hit. In the alternative, roll percentile dice: 01-25% One. 26-50% Two. 51-75% Three. 76-00% All four at the same time on the same target.

Payload: 8 total. Four shells per each side of the hammer. Must be reloaded by hand. Loading a single shell counts as two melee actions.

Cost: 17,000 credits for the weapon (includes silver-plating). 120 credits per shell or 16,000 credits for a gross (box of 144 shells).

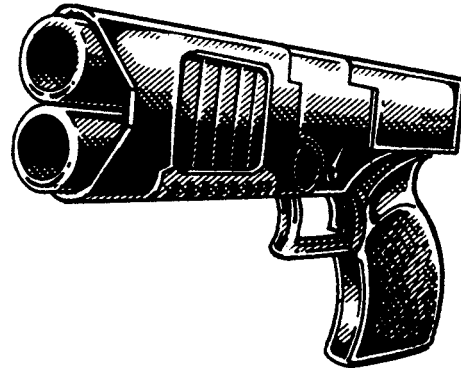

NG-11S Sawed-Off

A serious shotgun, designed by **Martin Schultz** and **Steven A. Hauser**, to compete with similar weapons from Bandito Arms, this .60 caliber smoothbore fires normal shotgun shells, explosive versions, ramjets and even Bandito’s signature BigBore ammo. Its two barrels can be fired at the same time or separately (requires one melee action to reload) and the shotgun is surprisingly light and easy to handle for a Northern Gun weapon, without sacrificing durability.

Weight: 4 lbs (1.8 kg).

Range: Shotgun shells or slugs: 200 feet (61 m). Explosive Shells: 300 feet (91.5 m) and APRJ shells: 500 feet (152 m).

Mega-Damage: Varies with ammo type.

Shotgun Shell: 4D6 S.D.C. or 8D6 S.D.C. for a double blast at the same target (counts as one melee attack).

Solid Slugs: 5D6 S.D.C. or 1D6x10 S.D.C. for a double blast at the same target (counts as one melee attack).

Explosive Shell (Fragmentary): 2D6 M.D. to a 10 foot (3 m) diameter, or 3D6 M.D. to a 20 foot (6.1 m) diameter for a double blast (counts as one melee attack).

Explosive Shell (Plasma): 3D6 M.D. to a 6 foot (1.8 m) diameter area, or 5D6 M.D. to a 12 foot (3.6 m) diameter area for a double blast (counts as one melee attack).

APRJ (Armor-Piercing, Ramjet) Rounds: 3D6 M.D. per shot, or 6D6 M.D. for a double blast at the same target (counts as one melee attack).

Rate of Fire: Each single or double shot counts as one attack.

Payload: Two shots. Reloading the gun takes three melee actions.

Cost: 6,000 credits. Explosive Shells cost 150 credits apiece; APRJ rounds cost 200 credits each at most places; poor availability and rising prices.

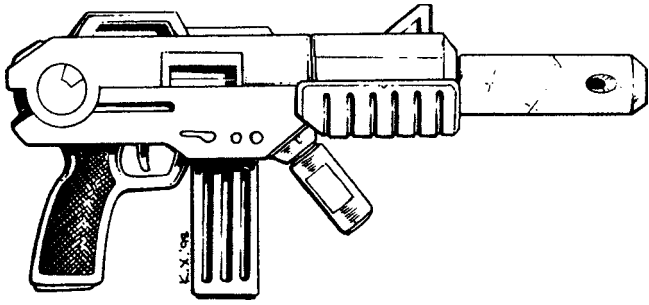

NG-R50 Mini-Rail Gun

Unlike most rail guns, the R50 is light and compact, firing large caliber single shells rather than bursts of small projectiles. The technology behind it led to the new 505 rail cannon and Research & Development is strongly considering a range of semi-automatic, large bore rail guns. The NG designers behind this

weapon systems were **Brian Lindholm, Sean Jenkins and M. Sumimoto.**

Weight: 25 lbs (11.3 kg).

Range: 1,500 feet (457.2 m).

Mega-Damage: 4D6 M.D.

Rate of Fire: Each shot counts as one melee action.

Weight Penalty: A P.S. of less than 20 imposes a penalty of -3 to strike on the shooter.

Payload: 14 round capacity from a short ammo clip powered by a standard E-Clip or 24 rounds from a banana ammo clip powered by a long E-Clip. A small, portable Power Pack can be used as an alternative to provide enough energy to fire 192 rounds, but weighs 20 lbs (9 kg) and costs 30,000 credits all by itself.

Cost: 30,000 credits for the mini-rail gun, two credits per ammo round and extra for E-Clips (standard short E-Clip costs 6,000 credits, a long E-Clip costs 11,000 credits and typical E-Clip recharge costs 1,500 and 2,000 respectively).

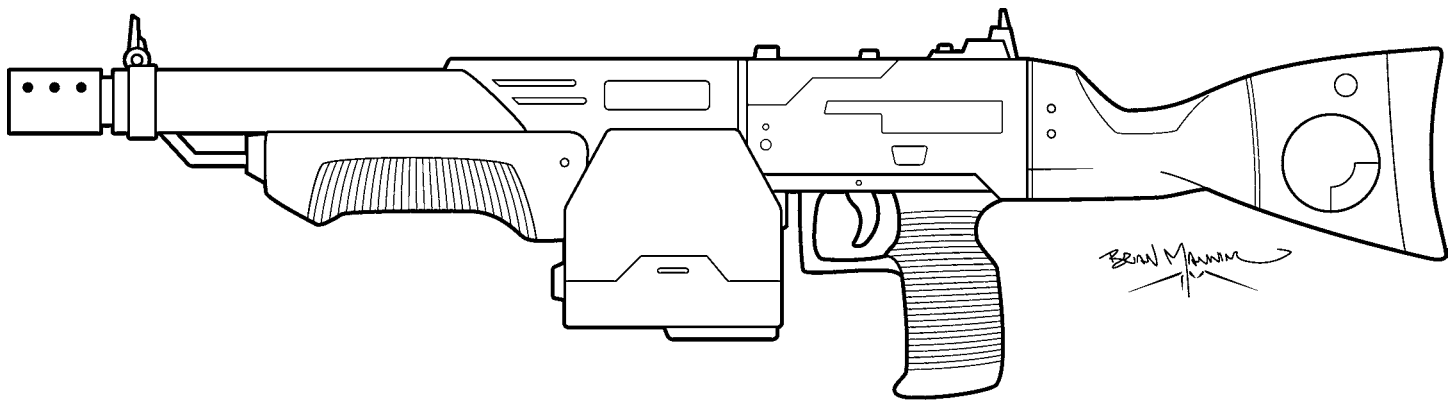

NG-101 Rail Gun

An older weapon that has been mainly pushed aside by newer models, the 101 was scheduled to end its production run three years ago when a dramatic redesign saved it at the last moment. The new Block III variant has retained the best features of the original, but combines them in a much lighter overall package.

Weight: Block I & II Gun: 128 lbs (57.6 kg). Block III: 90 lbs (40.5 kg). Power Pack for Block I & II: 80 lbs (36 kg), Block III: 52 lbs (23.4 kg). One Ammo-Belt: 25 lbs (11 kg). Case of six belts: 160 lbs (72 kg).

Range: 4,000 feet (1,219 m).

Mega-Damage: A burst is 30 rounds and inflicts 6D6 M.D., one round does 1D4 M.D.

Rate of Fire: Each single shot or burst counts as one melee attack.

Payload: As a machine-gun: 300 round belt.

Cost: 70,000 credits for the gun and power pack. Used NG-101s sell for 35,000-40,000 and have fair availability throughout North America. Block IIIs have good availability at Ishpeming, but poor in most other places.

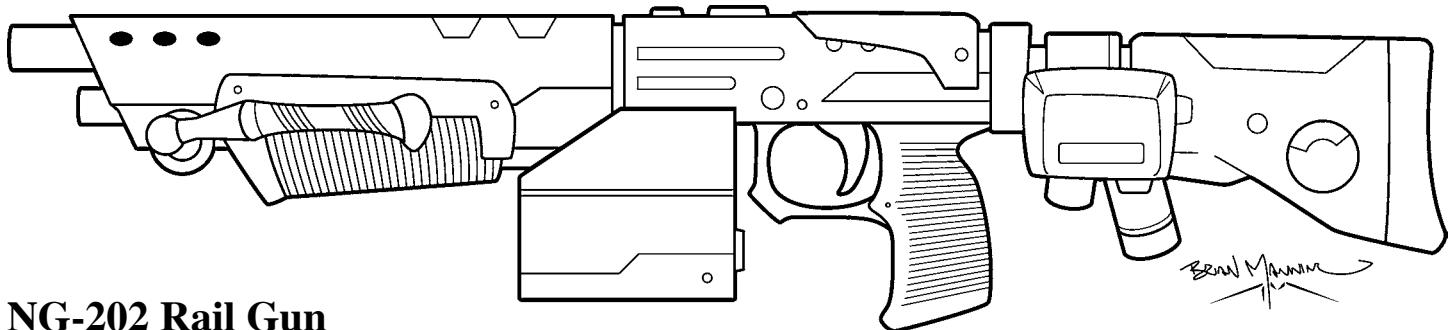

NG-202 Rail Gun

An old favorite and hot seller for many decades, the NG-202 is arguably the most common rail gun in North America, and shows up mounted on vehicles and fortifications all over the continent. It is a high-powered weapon suitable for a wide range of combat missions for Combat Robots, power armor troops and powerful

D-Bees. (Brodkil love the weapon too, whenever they can lay their hands on them.) Now available as the R212 robot-sized rifle version that fires extended bursts.

Weight: Gun: 198 lbs (89 kg), Power Pack: 100 lbs (45 kg), One Ammo-Belt: 35 lbs (16 kg), Case of six belts: 210 lbs (94.5 kg).

Range: 4,000 feet (1,219 m).

Mega-Damage: A burst is 40 rounds and inflicts 1D4x10 M.D. One round does 1D4 M.D.

Rate of Fire: Each single shot or burst counts as one melee attack.

Payload: 320 round belt (8 bursts). New is a 2,400 round drum (60 bursts) that weighs 175 lbs (79 kg) for those strong enough to manage such weight, such as heavy power armor suits and mon-

sters like the Brodki. Cyborg or strong D-Bees crazy enough to strap on the big ammo drum see their Spd reduced 30% and they are -3 to dodge and roll with impact.

Cost: 70,000 credits for the gun and power pack; good availability. Used NG-202s sell for 50,000-65,000 and have good to excellent availability throughout North America.

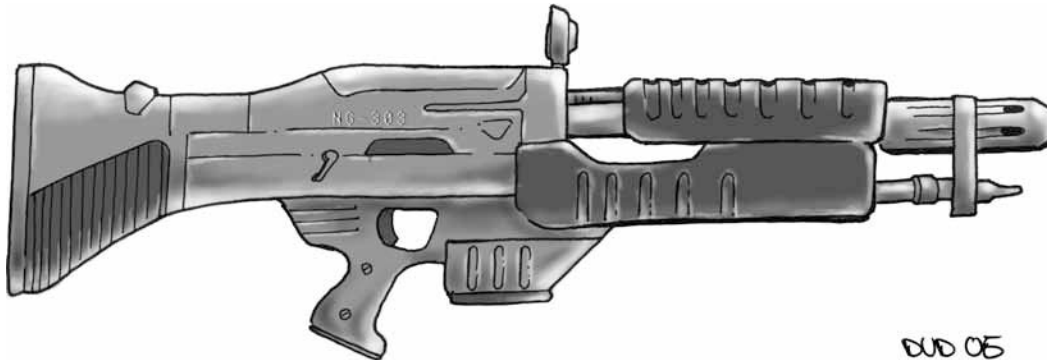

NG-303 Infantry Mini-Rail Gun

Borrowing a few ideas from Triax and Bandito Arms products studied by NG's R&D division, team leaders **Matthew Wontroba**, **Donald Dalton** and **Michael Ivie**, the NG-303 is a rail gun light enough for infantry soldiers. It still requires a strong arm and a steady hand to keep it under control, but the gun's only real drawback is the rate that it burns through ammo.

Weight: 27 lbs (12.2 kg), which includes the weight of a full ammunition drum.

Range: 2,000 feet (610 m).

Mega-Damage: 1D4 M.D. for a single round, a burst is 10 rounds and inflicts 4D6 M.D.

Rate of Fire: Each ten round burst counts as one melee attack.

Weight Penalty: If the operator's P.S. is less than 21, he suffers a penalty of -2 to strike.

Payload: Ammo drum holds 200 rounds or 20 bursts. The NG-303 uses a long E-Clip, which provides enough power to fire 40 rounds. Backpack mounted ammo-drum, typically used by cyborgs and others with bionic or better P.S., holds 600 rounds and can fire 60 bursts.

Cost: 68,000 credits for the gun, standard drum magazine costs an additional 1,000 credits, the backpack 2,800 credits.

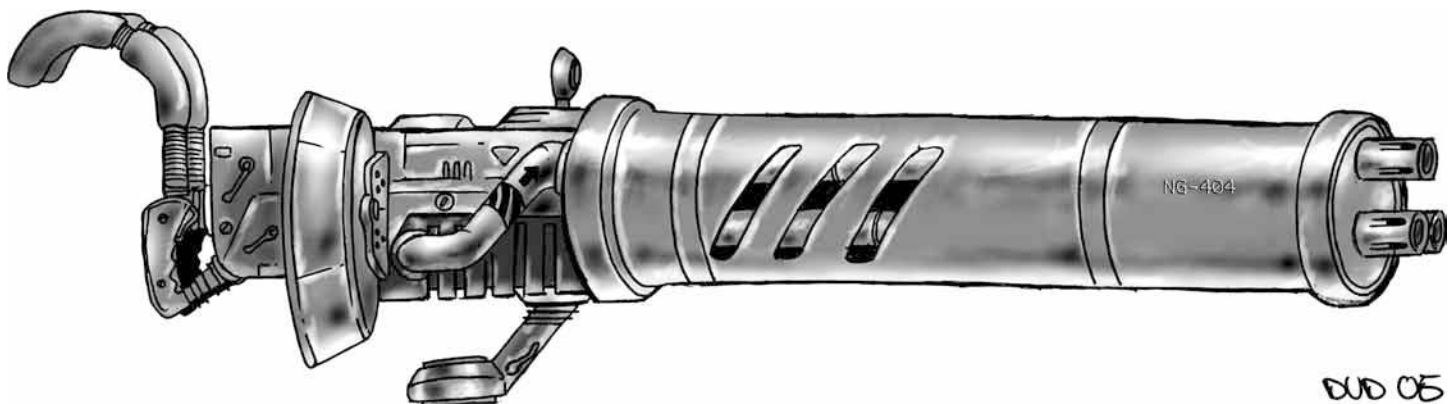

NG-404 Heavy Rail Gun

The NG-404 is a rail gun that fires larger-than-average ammunition. Shooting in controlled bursts, it deals out massive damage from its three rotating barrels and has incredible range and stopping power. The 404 is popular as a mounted weapon on tanks, APCs and robots, and is used as a larger alternative to the NG-202 on gun emplacements and guard towers throughout Ishpeming, particularly at anti-aircraft sites.

Weight: 460 lbs (207 kg).

Range: 5,000 feet (1,524 m).

Mega-Damage: 1D6 M.D. for a single round, or a burst of 20 rounds that inflicts 1D6x10 M.D.

Rate of Fire: Each burst counts as one melee attack.

Weight Penalty: Even if they can carry the weapon, shooters with a Robotic/Supernatural P.S. of less than 30 are -10 to strike.

Payload: 600 rounds (30 bursts) in a disintegrating link belt, ammunition belts come pre-packaged in metal ammo cans. It takes two melee rounds (30 seconds) for a two-man team to reload. Energy is provided by a portable power generator which can fire 1,200 bursts before needing to be recharged, or can be linked to a vehicle's nuclear power supply for unlimited firing capacity. An ammo drum (it has 35 M.D.C.) contains 2,400 rounds (120 bursts) can be fitted on some of the largest vehicles but is extremely uncommon.

Cost: 120,000 credits for the gun, 600 round ammo canisters cost an additional 2,000 credits each, a 2,400 round drum costs 8,000.



NG-505 Heavy Rail Cannon (new)

The 505 is an intimidating rail cannon that fires a single, large, aerodynamic shell. It is designed as a primary weapon for mounting on tanks, combat vehicles and as a light naval cannon, but can be switched out as a replacement for the main weapon system or large secondary weapon on certain large combat robots like the Hunter Mobile Gun and Gunbot. There is even a “ship-hunter” variant of the Beachmaster robot that mounts the weapon.

Weight: 612 lbs (275 kg).

Range: 4,000 feet (1,219 m).

Mega-Damage: 1D6x10+3 M.D. to a three foot (0.9 m) radius.

Rate of Fire: Each shot counts as one melee attack.

Payload: The secondary feeding drum built into the rail gun is permanently attached and serves as the only ammo source when using the 505 as a mounted cannon or a hand-held weapon for a combat robot or large monster. The built-in feeding drum holds 30 rounds. Full-size, 90 round drums are also available for use with the weapon system.

Cost: 175,000 credits for the gun alone. The ammo drum (30 M.D.C.) itself costs 2,000 credits each. 1,200 credits per each shell.

NG sells a servo-rig for 15,000 credits that can mount and fire the 505 with a turret but does not protect the gunner. There is also the rifle version available that requires a Robotic P.S. of 35 or greater (or supernatural P.S. of 25) to use and comes with a single 90-round drum and ammo system.

The last variant is the towed artillery field gun, a 505 cannon mounted on a light M.D. carriage (65 M.D.C.) that includes four spiked “feet” that are pounded in the ground to anchor the gun for firing. It takes about four melee rounds to get the weapon anchored; firing without properly securing the gun imparts a -4 penalty to strike.

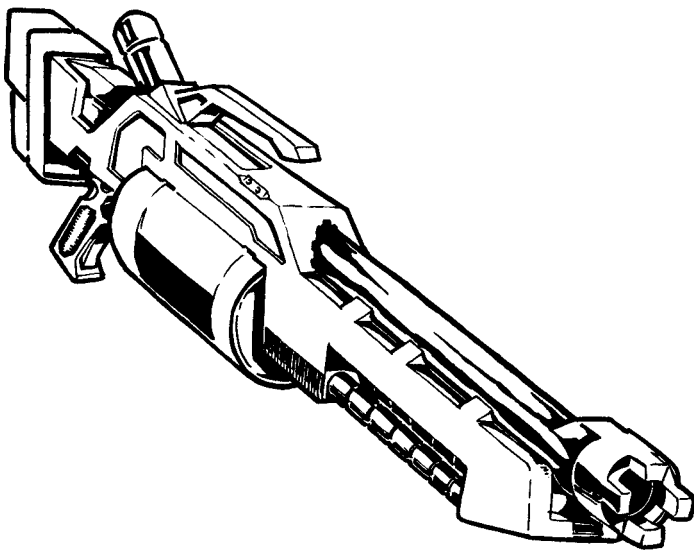

NG-1001 Robot Rail Rifle

A big, bad weapon famous for its use in the Robodome gladiator games, the 1001 is basically an oversized assault rifle that weighs as much as two grown men. Giant robots and NG power

armor can use the Rail Rifle as an additional hand-held weapon or as a replacement for a primary weapon system, and its independent power supply means giant D-Bees, demons and Golems can also wield the NG-1001. The ammo drum can be hooked to the back of most humanoid robots and has a belt feed to the weapon itself (the drum as shown in the weapon illustration is its energy canister).

Weight: 350 lbs (157.5 kg) for the gun, 330 lbs (148.5 kg) for the ammo drum.

Range: 4,000 feet (1,219 m).

Mega-Damage: A burst is 20 rounds and fires explosive rounds to inflict 1D6x10 M.D. or conventional rail gun rounds to inflict 4D6 M.D. per 20 round burst.

Rate of Fire: Each burst counts as one melee attack.

Payload: 920 rounds or 46 bursts per ammo drum.

Cost: 95,000 credits for the rail gun, 4,000 credits per ammo-drum with explosive rounds (exclusive to this weapon) or 2,000 credits for conventional rail gun rounds. A robot or power armor suit can be equipped with energy ports in the right or left forearm or shoulder at a cost of 30,000 credits, or the back for 25,000 credits, hooking the NG-1001 to the robot’s nuclear power plant.

NG-R1002

Robot Rail Gun/Assault Rifle

The classic NG 202 has been enlarged and re-imagined by **H.E. Werkheiser** and **Scott Leopold** as a handheld weapon for giant combat robots. It looks very much like the original with a few minor tweaks like no trigger guard. Even as a larger weapon, in the hand of most giant robots, it more resembles an assault rifle. Range is unchanged, but big robots can carry a bigger ammo drum, giving the R1002 a larger payload.

Weight: Gun: 265 lbs (119 kg), Power Pack: 100 lbs (45 kg), 2,400 round ammo drum: 175 lbs (79 kg) or 4,800 round ammo drum: 350 lbs (157.5 kg), or 6,000 round drum: 500 lbs (225 kg).

Range: 4,000 feet (1,219 m).

Mega-Damage: A burst is 40 rounds and inflicts 1D4x10 M.D. One round does 1D4 M.D. The NG Super variant fires 60 round bursts that inflict 1D6x10 M.D.

Rate of Fire: Each single shot or burst counts as one melee attack.

Payload: 2,400 round drum (60 bursts) or 4,800 round ammo drum (120 bursts), or 6,000 round drum (150 bursts) that weighs 500 lbs (225 kg).

Cost: 100,000 credits for the gun and power pack (may be tied directly into the robot's power supply). Ammo canisters each cost an additional 8,000 credits, 14,000 credits and 18,000 credits, respective to size. Fair availability at NG outlets throughout North America; poor elsewhere.

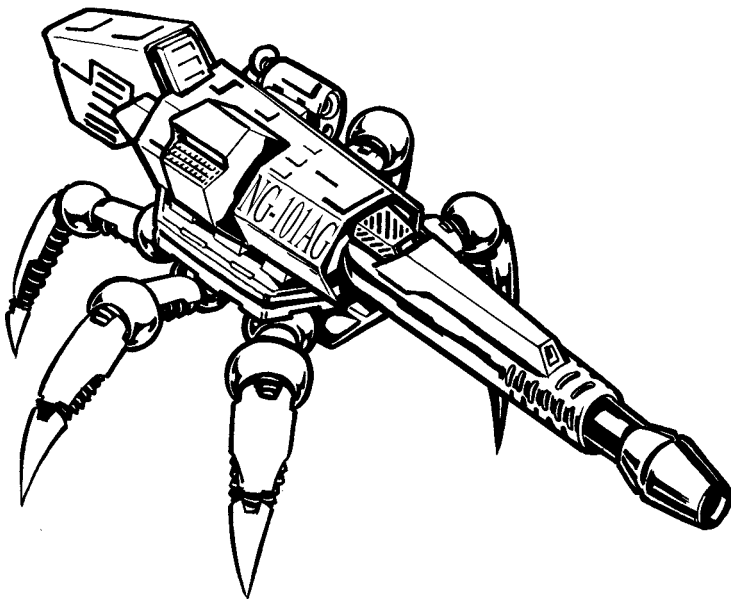

NG-101-ARG Automated Rail Gun

David A. Lang, **Curtis Fielder** and **Sara McLaughian** were the lead designers of this nasty weapon drone. Northern Gun's ARG 'Argonaut' is an NG-101 rail gun equipped with legs and a computerized brain that allows it to operate on its own. Customers who expect something on par with a Coalition Skelebot will be left very disappointed, but the ARG is much more capable than a standard sentry gun. It is able to relocate itself to a better position, retreat if overwhelmed or pursue an enemy attempting to retreat. Smart as it may be, the gun is still somewhat indiscriminate, shooting at any target that enters its field of vision. It is not suited for use at security checkpoints where it will have to distinguish

between friend or foe, but it excels at keeping stretches of wilderness clear of intruders, defending no-man's zones and strategic positions to ambush enemies. ARGs can be found watching over the most remote stretches of the western border with the Wisconsin Wild Land. They are most effective, however, in tunnels and corridors where an enemy cannot use stealth or the terrain to circle around behind the gun.

Weight: 285 lbs (128.2 kg).

Range: 4,000 feet (1,219 m).

Mega-Damage: 6D6 M.D. per 30 round burst.

Computer Targeting System: The computerized sensor suite and targeting module has a detection range of one mile (1.6 km) with an equivalent Read Sensory Equipment skill of 74%. Its targeting computer provides the equivalent of +3 to strike on a burst and has three attacks per melee round.

Payload: An ammunition drum that holds 1,200 rounds (40 bursts) is standard and provides full mobility. However, the Argonaut can be hooked to an ammo-block with 4,800 rounds (160 bursts) but the auto-gun is fixed to that position like a pit bull chained to a fence post. It can maneuver and change its direction, but can't go more than six feet (1.8 m) from the ammo block without disconnecting itself from it. In any case, once this ammo is exhausted the system is rendered harmless, although it can be manually reloaded (operators and loaders carry a sensor that tells the gun that they are "friends") or the unit can be programmed to return to base, a mobile command center or checkpoint for more ammo or collection.

Power System: Solid Oxide or electric battery.

Notable Features: In addition to the computer, sensors and combat capabilities already noted, the rail gun can turn 180 degrees on its robot legs and point up and down in a 30 degree arc of fire without having to use its legs to reposition. The legs can squat and position to provide a greater arc of fire, up to a 45 degree angle.

Maximum Running Speed: 20 mph (32 km) and can navigate rugged terrain, crawl over and under debris, and manage inclines up to a 50 degree angle.

M.D.C. by Location:

Control Pad (1) – 6 (attackers are -9 to strike it)

Legs (6) – 15 each (attackers are -4 to strike)

Rail Gun (main body) – 100

Cost: 225,000 credits Solid Oxide, 185,000 electric battery. 5,000 credits per ammo drum (1,200 rounds) and 18,000 credits per ammo-block (the casing has 50 M.D.C. and holds 4,800 rounds).

Other Weapons and Ammo Manufactured by Northern Gun

NG Specialty Rail Gun Ammunition

Standard Ammunition: Northern Gun sells a variety of rail gun rounds to fit the various calibers found in North America.

Cost: 2-3 credit per standard round on average (plus cost of belt or ammo drum). Bulks order will often receive a discount cost of 10% for orders over 10,000 rounds.

Monster Tracker Rounds: For years, Northern Gun consumers have complained of the supernatural menace that got away only to reappear minutes or hours later fully healed. The common tactic these creatures employ involve hit and run tactics and fleeing before slain to allow their superhuman regenerative powers to heal them to a significant level (if not completely), so they may attack again and again, whittling down their opposition through attrition alone. This has made fighting them very difficult and deadly. Physical tracking devices were often not strong enough to survive a battle or would be ejected from the creature's body as it healed. These creatures always had a means of escaping and coming back fully healed. Many of these monsters foolishly fight to the last minute before making their escape and if they could be quickly tracked down, they could be re-engaged before they were able to heal.

Northern Gun has tried for years to come up with different solutions but to no avail until someone in their sports and recreation department suggested using paintballs. It was an off the cuff remark that got the R&D techs under team leaders **Alexander Heck** and **Ryan Wiebens** thinking in a different direction. A specially made rail gun round with a *radioactive isotope* could be used as a tracking device. Also, the isotope has a very short half-life once activated, and within 48 hours it is inert, and not harmful to the environment. The liquid radioactive isotope also appears as a clear liquid like water but glows brightly in the infrared spectrum and will drip to leave a trail that can often be followed, at least for a short distance.

In order to be effective, 10% of the standard ammunition needs to be replaces with the tracker rounds.

Tracking Bonus: They will provide a +10% to the tracking skill, but there is a -10% on damage inflicted. Reduce rail gun damage accordingly, rounding down.

Cost: 4 credits a round.

Armor Piercing Rounds: Just like the mini-missile, these rail gun rounds have a special chemical coating allowing for easier penetration. Damage is not increased but they do provide a Critical Strike on a Natural 19 or 20.

Cost: 10 credits per round.

Shredders: The newest specialty rounds developed by **Matthew Daye** and **James Koski** were released earlier in the year (109 P.A.). They are called Shredder rounds. So named because upon impact, they balloon out like a flower petal, creating a larger bullet with serrated edges. Most targets appear to be shredded

after receiving multiple bursts. Damage is increased as follows. +2 M.D. for each burst of 20 rounds, so a 40 round burst would be +4, a 60 round burst +6 M.D., and so on. Due to weight and design, the effective range is reduced by 20% when 2shredder rounds are used.

Cost: 8 credits per round.

NG Explosives

NG Hand Grenades

Northern Gun produces its own line of grenades. They are cheaper, but slightly less powerful than the Coalition equivalents. The company also makes CS equivalent hand grenades and sells them for the usual price (see page 260 of **Rifts® Ultimate Edition**).

Fragmentation: 2D4 M.D. to a 20 foot (6.1 m) area.

High Explosive: 3D4 M.D. to a 6 foot (1.8 m) area.

Plasma: 4D6 M.D. to a 12 foot (3.6 m) area.

Smoke: No damage, but creates a smoke screen that covers a 40 foot (12 m) area.

Range: Average Throwing Distance: About 120 feet/36 meters.

Cost: 160 credits for fragmentation, 120 credits for high explosive, 275 credits for plasma, and 50 credits for smoke.

Plastique & Other Plastic Explosives

Plastique is a wax or clay-like explosive that can be shaped like putty into a patty, block, rope or blob. It will not detonate if it is dropped, shaken, shot, blasted, or set on fire. It is detonated by an electric charge usually contained in a blasting cap. However, it can be detonated by lightning or Electrokinetics. The explosion is usually contained mainly to the area where the plastique was placed, causing little shrapnel and putting the full force of the explosion on one concentrated area. Plastique is used for safe-cracking, sabotage and other precision explosions to blow out locks, open safes, cut girders, set off other explosives, etc. Plastique comes in both S.D.C. and M.D. varieties.

Commercial Plastique: S.D.C. damage: 1D4 per ounce (28 grams) or 1D6x10 per pound (0.45 kg); cost: 5 credits an ounce.

C4 (military HE) Plastique: S.D.C. damage: 1D6 per ounce or 2D4x10+20 per pound (0.45 kg); cost: 8 credits an ounce.

S.D.C. Dynamite: 5D6 S.D.C. per stick; cost: 10 credits each.

M.D. Dynamite: 2D4 M.D.C. per stick; blast radius of 10 feet (3 m); cost: 130 credits per stick. Fair availability. A stick of dynamite is usually placed and detonated. It is not made for throwing. Maximum effective throwing range: 30-40 feet (9-12 m).

NG 2 M.D. plastique: M.D. damage: One point per ounce or 1D6 M.D. per pound (0.45 kg); cost: 20 credits an ounce or 320 credits per pound. Fair availability.

NG 4 M.D. plastique: M.D. damage: 1D4 points per ounce or 1D4x10 M.D. per pound (0.45 kg); cost: 40 credits an ounce or 640 credits per pound. Poor to fair availability.

NG 6 M.D. plastique: M.D. damage per ounce: 1D6 points per ounce or 2D4x10+20 M.D. per pound (0.5 kg); cost: 60 credits an ounce or 960 credits per pound. Poor to fair availability.

Blasting Cap: S.D.C.: 5 credits or M.D.C.: 40 credits.

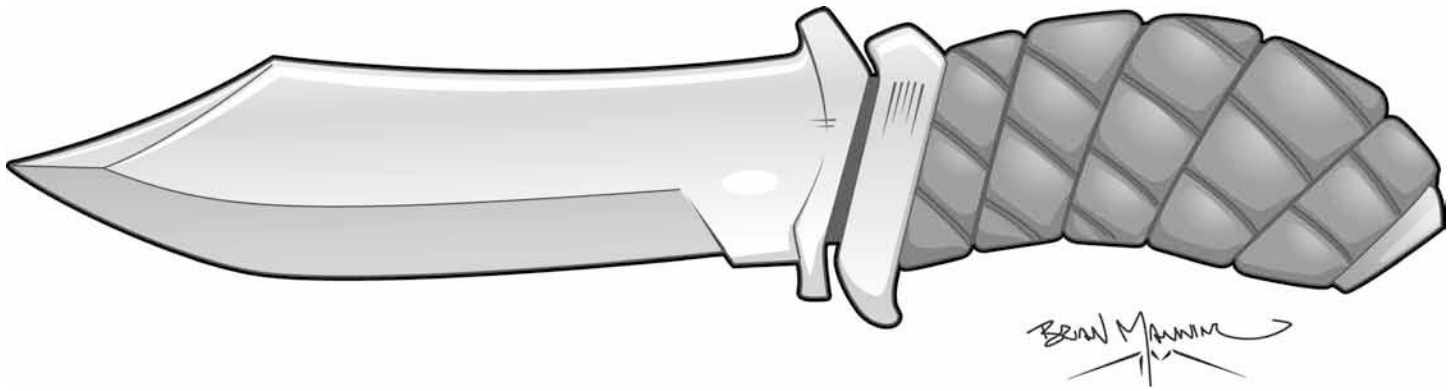

Grenade Knives (new)

Grenade knives are a simple and clever weapon that have become popular with Juicers, Crazies and others who tend to fight in close combat. They were conceived by the design team of **Trent Slater, Nolen Keith** and **Jeff Woodman**. Grenade knives are just what they sound like, knives with fragmentation grenades for handles. Once the target has been stabbed, the grenade is activated and detonates, all the while held closely against the intended victim by the blade itself. There are both normal and Vibro-Blade versions available, insuring the weapons can be used against supernatural creatures and armored targets. **Note:** W.P. Targeting is necessary to have any hope of hitting a target by throwing the weapon at a distance and is still -1 to strike. Unskilled users may be able to hit a target with a thrown weapon within 15 feet (4.6 m), but are -3 to strike.

A new release for NG, it is yet to be seen how popular this unusual weapon may become. However, Grenade Knives have met with instant appeal amongst Crazies, Juicers, Headhunters, Raiders, saboteurs, espionage agents and gladiatorial combatants. **Weight:** One pound (0.45 kg).

Range: Grenade knives are much heavier than normal throwing knives and have a limited range of about 30 feet (9 m).

Mega-Damage: S.D.C. Blade: 1D6 S.D.C. on blade impact. Vibro-Blade: 1D6 M.D. on blade impact/impalement. The secondary explosion occurs one melee action (about 3 seconds) later and delivers 4D6 M.D. to the target in which the Grenade knife is imbedded and 1D6 M.D. to those within a 4 foot (1.2 m) blast radius. Only individuals on the same side of the target where the knife struck are affected; those on the opposite side are protected from the blast by the main target's body/armor. Note that S.D.C. blades will bounce off Mega-Damage armor and the skin of most Mega-Damage creatures – bounces 2D4 feet (0.6 to 2.4 m) away and may inflict collateral damage to any person or object within the blast radius. But that's true of all grenades and explosives, which is why they should always be used with extreme caution. **Note:** The blade of the grenade is destroyed in the explosion.

Cost: S.D.C. Grenade Knife: 450 credits each. Vibro-Blade: 9,500 credits each. Add 500-1,200 credits for a silver-plated blade.

NG-GL10 Grenade Launcher

The GL10 is one of Northern Gun's big successes, a versatile grenade launcher with a wide variety of ammo that rivals competing products from Wellington Industries. Appearing mounted on power armor and robots and in the hands of police and mercenaries, its popularity both with customers and with the company's

weapons techs has led to a lighter, more manageable Block II model.

Weight: 25 lbs (11.3 kg), (19 lbs/8.6 kg for GL10 Block II). Clips add 1.5 lbs/0.7 kg, drums 6 lbs/2.7 kg and fully-loaded ammo packs weigh roughly 15 lbs/6.8 kg.

Range: 1,000 feet (305 m).

Mega-Damage: 3D6 M.D. to a 12 foot (3.7 m) radius for fragmentation grenades, 4D6 M.D. to a 3 foot (0.9 m) radius for high explosive/armor piercing grenades, 6D6 M.D. to a five foot (1.5 m) radius for plasma grenades, while a smoke grenade covers a 40 foot (12.2 m) radius in a dense cloud of smoke obscuring vision and creating cover, a tear gas grenade covers a 25 foot (7.6 m radius) and makes the eyes and nose of victims not protected by gas masks or environmental armor burn and tear, as well as gag and choke them (-10 to strike, parry, dodge, -3 on initiative and lose one melee attack as long as they are in the gas cloud and for 1D6+1 melee rounds after exiting it; protected individuals suffer no penalties), and stun or flash grenades unleash a bright flash, sparkles and white smoke that make victims -10 to strike, parry, and dodge, -1 on initiative, and lose one melee attack for 1D4 melee rounds.

Rate of Fire: Single shot only, each blast counting as one melee attack/action.

Payload: A six grenade clip, or 24 round drum or a backpack ammo-pack that carries up to 60 rounds.

Weight Penalty: Anyone with a Physical Strength under 20 is -2 to strike with the GL10.

Cost: 50,000 credits; includes 24 grenades. 500 credits each for plasma grenades, 350 for high explosive/armor piercing grenades, 200 credits each for fragmentation grenades, 250 for tear gas, 200 for stun grenades and 50 credits for smoke.

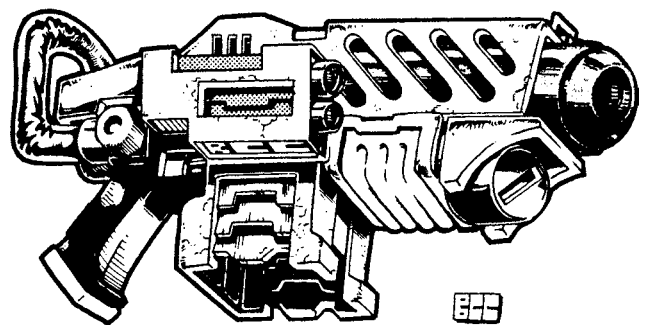

NG Mini-Missiles

Mini-Missile Price Summary:

Armor Piercing: 2,400 credits each.

Fragmentation: 1,200 credits each.

High-Explosive: 1,200 credits each.

Plasma/Napalm: 2,400 credits each.

Smoke/Tear Gas: 800 credits each.

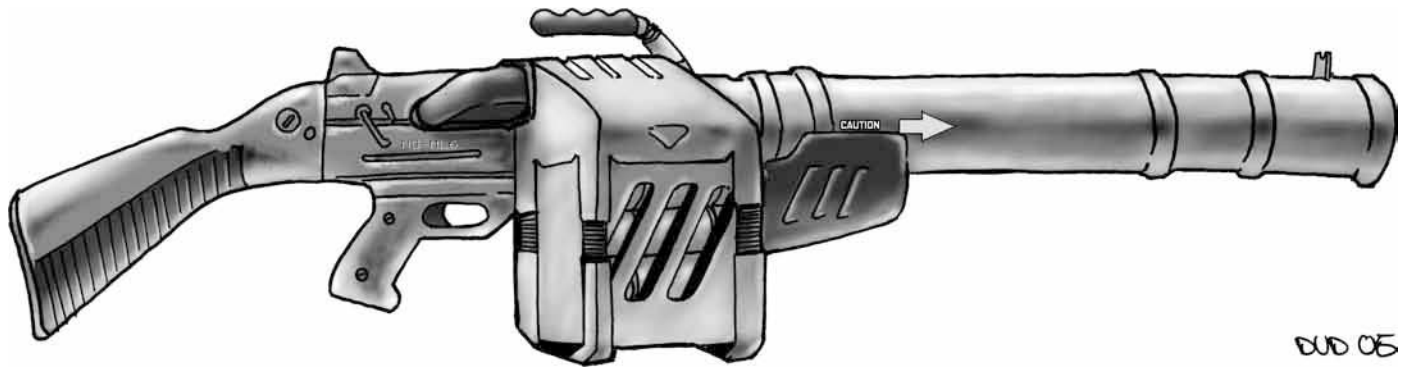

NG-ML6 Mini-Missile Cannon

Basically, a large, semi-automatic, smoothbore cannon, the ML6 uses compressed air to launch mini-missiles. Once they have reached a safe distance from the shooter, their rockets kick in, propelling them towards the target. While a bit heavy, the ML6 is reliable and accurate and almost foolproof for users who might not be familiar with the dangerous backblast most mini-missile launchers generate. Mini-Missile Cannons are showing up in the hands of many power armor troopers and cyborgs, and mercenary companies and local militias use two-man fire teams equipped with ML6s to ambush robots, tanks and giant monsters from foxholes, rooftops and concealed firing positions.

Weight: 16 lbs (7.2 kg) plus the weight of each mini-missile.

Range: One mile (1.6 km).

Mega-Damage: Varies with mini-missile type, the cannon can fire any standard mini-missile type but standard issue is armor piercing (1D4x10 M.D.) or plasma (1D6x10 M.D.).

Rate of Fire: One at a time, with each mini-missile fired counting as one melee attack.

Weight Penalty: Individuals with a P.S. attribute of 18 or less are -2 to strike unless the gun is operated by a two-man team.

Optics and Laser Targeting: Passive nightvision (3,000 feet/914 m range), thermal imaging (1,200 feet/366 m range) and laser targeting (3,000 feet/914 m range; provides a bonus of +1 to strike).

Payload: 6 mini-missiles packaged in a disposable box magazine. Reloading the magazine is a simple task that takes just two melee attacks/actions.

Cost: 72,000 credits for the weapon, additional missiles are 2,000 credits for armor piercing and 3,000 for plasma.

NG-ML7 Mini-Missile Launcher (new)

The ML7 is a mini-missile launcher designed to compete with Wellington Industries' extremely popular WI-23. The weapon's missile clip provides more ammunition than standard one-shot launch tubes, and Northern Gun wanted to provide a similar capability for their customers. While NG does sell knock-offs of the

WI-23 mini-missile launcher as the NG-ML46, its own shoulder-fired mini-missile system has its own strengths and weaknesses.

The greatest advantage to using the NG-ML7 is its ability to fire in salvos. Normal mini-missile launchers intended for infantrymen have a single launch tube and must be fired one at a time. The ML7 has four tubes in a quad configuration, allowing for multiple missiles to be fired at once or for different types of missiles to be loaded and kept at the ready. The weapon's drawback is its weight and bulk, but neither seem to be stopping customers from making purchases.

Weight: A fully loaded launcher weighs 30 lbs (13.5 kg).

Range: About one mile (1.6 km).

Mega-Damage: Varies with missile type. Armor piercing (1D4x10 M.D.) or plasma (1D6x10 M.D.) are standard.

Rate of Fire: One at a time or in volleys of two or four.

Payload: 4 mini-missiles. Reloading all four missiles requires 8 melee actions/attacks.

Cost: 34,000 credits.

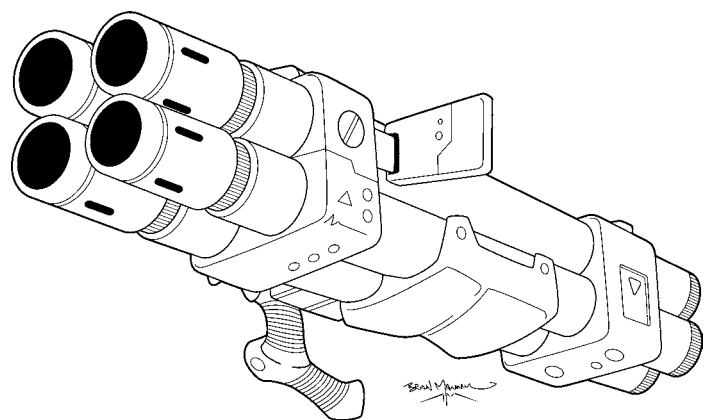

NG Mines

Northern Gun has offered a number of simple land mines for anti-vehicle and anti-personnel purposes for years. Strange as it may sound, few military groups, mercenary companies and kingdoms use mines, and nobody knows why, exactly. Some speculate that this is one weapon in which sentient beings have learned from the past, inflicts too much collateral damage upon innocent people. Others have speculated that the culture of Rifts Earth is such that combatants simply prefer more 'in-your-face' weapons and battles, and combat that requires skill. Whatever the reason, mines are uncommon and amongst Northern Gun's worse selling product lines. Availability of all mines is poor even at NG outlets.

Detecting Mines: Traveling on foot and looking for mines, the detect ambush or detect concealment skills at -10% can be used to spot land mines and booby-traps.

Vehicles can be outfitted with a basic mine detector for 50,000 credits. This unit has a 40% chance of locating mines before they are struck and detonated, but will also indicate harmless metal fragments as well (fragments must be the size of a soccer ball or bigger). The basic system can be "fine-tuned" and enhanced +10% for an additional 20,000 credits up, to a maximum of 90% efficiency, but those are rare (most are at 70%). A pilot can try Trap/Mine Detection skill rolls, but is -25% even if traveling at a crawl and -50% if traveling at over 30 mph (48 km).

NG Anti-Personnel Mines

These mines typically use fragmentary or incendiary charges designed to inflict damage to a large area, crippling troops with shrapnel or fire. Most are triggered by snapping a trip wire or responding to pressure/weight (100 lbs/45 kg or more).

Sensor Special: High-tech mines that come with special sensors that will detect a human-sized creature 6 feet (1.8 m) away, or a robot, cyborg, giant, or light vehicle up to 12 feet (3.6 m) away and detonate. The sensor types cost twice as much.

Mega-Damage: 4D6 M.D. to a 40 foot (12 m) area.

Cost: 600 credits for the standard mine, 1,200 with sensor.

NG Anti-Vehicle Mines

Most have a rudimentary electronic sensor suite that can be programmed to detonate the explosives when a target of a pre-determined size comes close enough to be detected. The larger the size, the greater the detectable range. The weapon can also be triggered by a radio signal sent at a distance, (ambushers can wait until the target is close enough, then detonate the explosive).

Type One: NG Light Anti-Vehicle Mine: Detects a vehicle of under 5 tons at 3 feet (one meter) away, a vehicle weighing 5-10 tons from 10 feet (3 m) away, and vehicles over 10 tons at 20 feet (6 m). People on foot only trigger it if they actually step over the mine, or if a remote controller detonates it by radio. Treat heavy creatures and humanoids weighing over 400 lbs (180 kg) as light vehicles.

Mega-Damage: Either high explosive (HE): 5D6 M.D. to a 20 foot (6.1 m) area, or plasma: 1D4x10 to a 30 foot (9.1 m) area.

Cost: 1,000 credits for HE, 2,000 for plasma.

Type Two: Medium Anti-Vehicle Mine: As above, but does more damage.

Mega-Damage: HE explosion does 1D6x10 M.D. and the plasma inflicts 2D4 x 10 M.D. (area and detection range remain unchanged).

Cost: 3,000 credits for HE, 4,000 for Plasma.

Type Three: Heavy Anti-Vehicle Mine: As above, but even greater damage.

Mega-Damage: HE explosion inflicts 2D6x10 M.D. and the plasma does 3D6x10 M.D.; both with a blast area of 70 feet (21 m).

Cost: 6,000 credits for HE, 8,000 for Plasma.

NG NM-3 Firefly Plasma Mine

The Firefly anti-personnel plasma mine. When triggered, a grenade-like plasma charge ignites from the mine casing, propelling it to a height of 3 feet (1 m) before exploding and showering the area with super-heated plasma. The mine uses two activation mechanisms, a pressure detonator that is activated by a weight of 50 lbs (22.5 kg) or more, or a trip wire that triggers the device when pulled.

Weight: 6 lbs (2.7 kg).

Mega-Damage: A direct hit is 5D6 M.D. to everyone in a 6 foot (1.8 m) radius. Anyone within 40 feet (12.2 m) takes 1D6 M.D.

Cost: 1,000 credits.

NG NM-4 Claymore

Based on the US Army M18A1 of antiquity, this is a modern claymore design that incorporates Mega-Damage explosives and very dense (i.e. M.D.C.) ball bearings similar to ammunition used for the NG-101 rail gun. The claymore is a directional blast mine that operates in a fashion similar to a shotgun shell. When the explosive charge detonates, it hurls nearly two hundred ball bearings in a 120 degree arc to a distance of 100 feet (30.5 m). This type of mine is normally command detonated, meaning that it is connected by "det cord" to a detonator held by a person who must trigger the mine manually. However, the claymore can be fitted with a sensor package capable of detecting motion and a human-sized target(s) or larger up to six feet (1.8 m) away and detonating.

Weight: 3 lbs (1.4 kg).

Mega-Damage: 4D6 M.D. to everything within six feet (1.8 m) of the initial blast and 1D4 to everything else within the blast radius.

Blast Radius: Special. This mine creates a directional, cone shaped blast that is 100 feet (30.5 m) long in a 120 degree arc.

Cost: 750 credits. Add 1,500 credits to the cost if fitted with a high-tech sensor.

NG NM-9 Plasmore Mine

Northern Gun also has developed a modern, high-tech version of the ancient US Army M18A1 claymore. Unlike the original, this version fires a stream of super-heated plasma in a directional blast, rather than hundreds of ball bearings. When the Plasmore detonates, it sends gobs of plasma in a 120 degree arc to a distance of 100 feet (30.5 m). This mine is highly effective, capable of disintegrating lightly armored troops and minor supernatural beings. The plasmore is usually command detonated, meaning that it is connected to a handheld detonator and is triggered manually. However, the plasmore can be fitted with a sensor capable

of detecting a human-sized target or larger up to 12 feet (3.6 m) away and detonating.

Weight: 4 lbs (1.8 kg).

Mega-Damage: 1D4x10 M.D. to those caught directly in its blast (within 12 feet/3.6 m) and 1D6 M.D. to everyone else in its blast radius.

Blast Radius: Special. This mine creates a directional, cone-shaped blast that is 100 feet (30.5 m) long in a 120 degree arc.

Cost: 1,000 credits. Add 1,500 credits to the cost if fitted with a high-tech sensor.

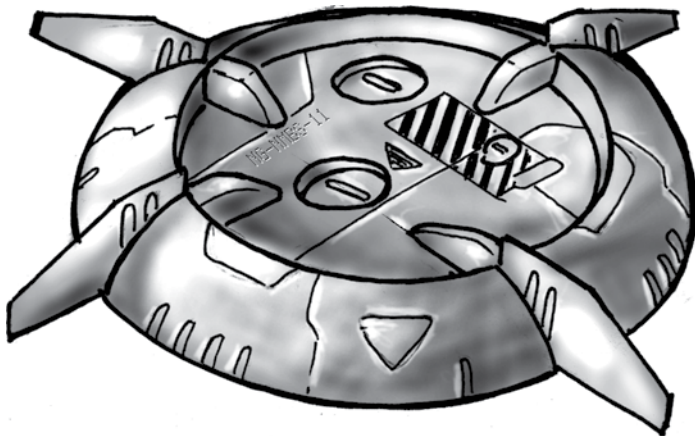

NG NMBS-11 Bio-Sensor Mine

The NMBS-11 is an anti-monster mine developed by NG for its CS allies. It is a simple, anti-personnel style explosive that produces a large blast with fragmentation. What makes the NMBS-11 unique is its high-tech bio-sensor triggering system – a sensor that recognizes the thermal signature, heart rate and other vital signs of humans (and most mortal humanoids) versus supernatural creatures, dragons, and monsters. The bio-sensor is programmed to ignore human and human-like signatures and will not detonate in their presence, however, if the system detects any large (man-sized and larger), inhuman creatures within range, it will automatically explode.

Thanks to this safety feature, the NMBS-11 is harmless to human beings and many (not all) D-Bees, but at the same time is highly effective against monsters. The CS army first deployed these mines in the last two years of the Tolkeen War without fear of producing any friendly casualties. Around that same time, the NMBS-11 was also released widely in North America where it has been purchased by predominantly human communities like Whykin, El Dorado and Free Quebec, as well as mercs and other outfits.

Weight: 3 lbs (1.4 kg).

Mega-Damage: 1D4x10 M.D. at point-blank range (within 6 feet/1.8 m) and 2D6 M.D. to everything within a 15 foot (4.6 m) blast radius.

Bio-Sensor: The sophisticated bio-monitoring sensor attached to the NMBS-11 is capable of detecting the vital signs of life forms within the mine's blast radius. Moreover, the sensor is able to differentiate between the vital signatures of human beings and monstrous creatures, detonating only when non-humans are present (Gargoyles, Brodkil, demons, dragons, etc.). The mine will not explode if a human is within the blast radius! Can scan as many as 12 different signatures at once.

Cost: 2,800 credits. Fair to poor availability in North America.

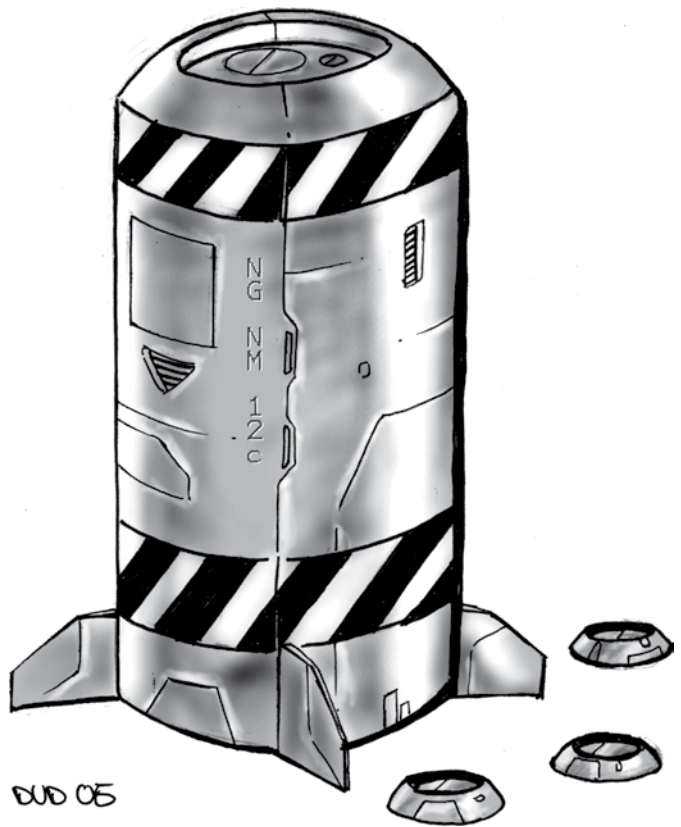

NG NM-12C "Smart" Scatter Mines

The NM-12C Scatter Mine is a cluster-style scatter device used by Northern Gun itself, the Coalition States, and several other CS allies like Whykin and El Dorado. Each individual NM-12C is a small device about the same size and shape as a hockey puck, with a micro-fusion charge and high-tech sensor. The sensor will detect a human-sized creature at a distance of 10 feet (3 m), or a cyborg, giant or robot up to 30 feet (9.1 m) away.

What makes the NM-12C unique is that 20 individual mines are packaged in a single canister. The canister is designed to be delivered by aircraft, artillery or missile launcher. In the air, the canister breaks apart, scattering the twenty mines within a 100 x 100 foot (30.5 x 30.5 m) area, creating an instant mine field. According to rumor, NG has special transponders that are instantly recognized and ignored by the NM-12C mine's high-tech sensor. This means that while these mines are lethal to all other forces, those with a transponder can walk right through a minefield of NM-12Cs without setting off a single one!

Weight: 1 lb (0.45 kg) each.

Mega-Damage: 3D6 M.D. per each of the 20 scatter mines to everything within a 5 foot (1.5 m) blast radius.

Cost: 4,800 credits for a NM-12C canister containing 20 individual land mines. **Note:** Limited to the Coalition States and its authorized allies. Neither the NM-12C mines or the transponder (1,200 credits) are sold to the general public. However, they are sometimes "captured" and retooled by rogue Operators and the Black Market so they can be used by people other than the CS. When available (rare), a ready to go canister costs 12,000 to 24,000 credits; transponders, 2,000-6,000 credits each.

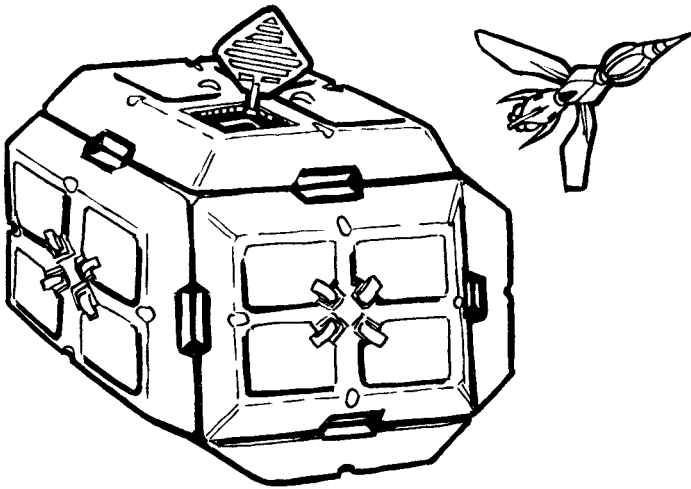

NG NMX-18 Stinger Anti-Flyer Mine

The Northern Gun Stinger Mine is a high-tech, computerized munition similar to the Wellington SAWS, only designed to engage flying targets. Originally conceived as an automated weapon defense system to engage dragons, demons, gargoyles and similar low-flying supernatural creatures, the Stinger is also effective against low-altitude, slow moving aircraft and vehicles such as Wing Boards, soldiers with jet packs, helicopters, hovercycles, flying power armor, flying sorcerers and similar aerial opponents. Thus, the NMX-18 may be programmed to target any flyer or to recognize and attack specific targets, up to 3,200 of them.

When the mine is placed, it may be programmed to engage a limited, specific number of targets (such as SAMAS power armor, Iron Eagle choppers, Juicer Icarus Flight System, Gargoyle, etc.) or a broad range (hundreds or thousands) and will ignore any others, or set to attack any and all flyers. When such a target passes within the system's detection range (2 miles/3.2 km), the mine is triggered, it releases one or more Stingers and the enemy is engaged. The Stinger is a unique drone warhead equipped with a hover propulsion engine and targeting system. The drone has limited maneuvering and its maximum speed is only 300 mph (480 km), but that is sufficient to catch most slow moving targets as well as to intercept fast moving ones coming in its general direction (but at -2 to strike). Furthermore, most civilians, low-tech people, adventurers and even a third of all mercenaries, have never seen or heard of this mine and misidentify the incoming warheads as birds, insects or something unknown, causing them to hesitate too long before taking evasive action (-3 on initiative and -1 to dodge).

Note: Sometimes called the "poor man's mini-missile."

Weight of Launch Cube: 45 lbs (20.3 kg). Stingers are one pound (0.45 kg) each.

Range: 3,600 feet (1,097 m).

Mega-Damage: 5D6 M.D. direct damage from the plasma warhead plus 1D4 M.D. to everything in a 30 foot (9.1 m) blast radius.

Blast Radius: 30 feet (9.1 m).

Rate of Fire: One at a time or in volleys of 2 or 4. The launch cube has three attacks/launches (single Stinger or volley) per melee round.

Computer Targeting System: The NMX-18 is equipped with a radar suite with a 2 mile/3.2 km range, an effective Read Sensory

Equipment skill of 88%, and computer recognition package equal to the Wilk's PC-2020 field identifier with an accuracy of 94%. All target data is uploaded to the drones prior to firing, making the drone system the equivalent of a smart missile with bonuses of +3 to strike, +1 to dodge incoming attacks and three attacks/actions per melee round until it finds its target, hits and detonates on impact.

Payload: 12 Stinger drone warheads. The launch unit can be physically picked up and relocated without disturbing the cube, however, trying to pry open any of the hatches or deliberately damaging the cube (it has 31 M.D.C.), will cause the cube to "retaliate," typically by launching one or two of its drones at the cause of the disturbance. Reloading takes about 5 minutes.

Note: The maximum speed of the drone is 300 mph (480 km), which means that it cannot effectively engage fast moving air targets; the system will not even fire at targets traveling faster than 300 mph (480 km) unless it has a chance of intercepting it should it come within 2,000 feet (610 m) of the launch cube.

Cost: 140,000 credits for the launch cube, plus the cost of the individual Stingers, 2,500 credits each. Fair to poor availability in North America.

Product Note

In addition to its own product line, Northern Gun also manufactures successful equipment originally produced by small kingdoms unable to keep up with demand or even direct knock-offs of competitors' products. Weapons like the L-20 pulse rifle, Vibro-Blades, environmental body armor like the Bushman, Plastic Man, Crusader and ATVs and vehicles like the Big Boss and Mountaineer, are all available in Northern Gun models, often for a slightly reduced price (10-15%).

NG Vibro-Blades

All Vibro-Blades are bladed weapons surrounded by an invisible, high-frequency energy field that gives them Mega-Damage capabilities. Vibro-Blades were originally designed by the CS, but have been "knocked off" by virtually every weapon manufacturer in the Americas, including the continent's largest weapons manufacturer, Northern Gun. Vibro-Knives, Claws and Sabers are widely available throughout North America (and Germany via a trade deal between the CS and Triax). In the CS they are exclusively issued to police and military personnel. It is illegal for private citizens to own a Vibro-Blade or any Mega-Damage weapon without a special and rarely authorized license.

In the rest of the world, Vibro-Blades are very common, thanks largely to Northern Gun and the Black Market. While designed to be a weapon, Vibro-Blades are also used as cutting and chopping tools by everyone from farmers and woodsmen, to adventurers and butchers of M.D.C. livestock.

Note: The W.P. Knife skill and bonuses apply to Vibro-Blades and Vibro-Claws. All are handheld weapons which means range is limited to hand to hand/melee combat. Most Vibro-weapons do not throw well and are half the range listed under the W.P. Targeting skill unless a character has an Augmented/Bionic P.S. of 22 or greater.

Vibro-Knife: **Mega-Damage:** 1D6 M.D. **Cost:** 7,000 credits.

Vibro-Bayonet. Mega-Damage: 1D6+1 M.D., designed for attachment to a variety of rifles, but rarely used by the CS. Cost: 7,500 credits.

Vibro-Saber (short sword). Mega-Damage: 2D4 M.D. Cost: 9,000 credits.

Vibro-Sword (large, one-handed sword). Mega-Damage: 2D6 M.D. Cost: 11,000 credits.

Giant-Sized Vibro-Sword. Mega-Damage: 3D6 M.D.; usually used by oversized power armor suits or by giant robot vehicles. Rarely used by the CS. Cost: 18,000 credits.

Vibro-Forearm Claws. Mega-Damage: 2D6 M.D.; usually three hooked blades attached to a forearm gauntlet or protective plate. Great for parrying (+1 bonus) and slashing. Cost: 11,000 credits.

Note: Also see Grenade Knife (new).

Dare to Imagine

From day one, my goal for Palladium Books® has never been to be the biggest game company, but to be the best. And by the best, I mean to unveil stories, characters and ideas that carry you away on the wings of imagination. I want to sweep you away to worlds you've never before imagined, take you on adventures you'll never forget, and give you characters and stories that become fond memories that bring smiles for years to come.

I want to unlock the imagination and show you that there are no limits, no boundaries, except those you impose upon yourself. I want to create products that compel you with art, words and ideas to create *your own* epic stories. Because once you learn how, there is no stopping you. There is no telling where your unconstrained imagination may carry you. And as with any muscle, the more you use your imagination, the stronger and more nimble it becomes.

To me, this is the wonder and beauty of **role-playing games** done well. They are an unparalleled medium of imagination. More than that, they inspire others to follow their own dreams. I truly marvel and stand humbled by the incredible number of talented people who tell me it is because of the worlds, art and stories of Palladium Books that they, themselves, have gone on to become artists, writers, game designers, actors, directors, business owners and storytellers of every kind. Others tell of how it helped them find themselves in other ways, or to connect with people or make it through difficult times. What a gift we have been given.

This very book is filled with the works of individuals who might not have discovered their love to create and tell stories with words and art if not for Palladium's role-playing games. Palladium Books helped them find the doorway to their imagination and the inspiration to walk through it. Once they did, there was no turning back. They had to follow their dreams. I count myself among them. Palladium has given me the vehicle with which to

share the wonders of my overactive imagination. It has helped me become a better storyteller and a wiser, better person. Your love for the worlds and characters 'we' have shared with you has allowed my own imagination to find heights I never knew I could reach. It is a wonderful, symbiotic relationship that invites my imagination to unlock even more new realms of adventure, new worlds to explore, new characters to play. Best of all, I'm not alone. There is a growing legion of creators being spawned in the *Palladium Megaverse* and coming forth with their own stories to share. They are making their presence known within and outside the realm of games, and it is a wonder to behold. I still find it hard to believe that it is because of anything we have done at Palladium Books. Beautiful. Amazing. Humbling.

The book you hold in your hand is only one more chapter in the unfolding saga that is **Rifts®**. It feels like **Northern Gun One** was a very long time in coming. We hope you find it was worth the wait. We hope you will see there is a lot of imagination and heart put into it along with several large doses of love. Love for the world in which it is set. Love for the work we did for it. And love for you, our supportive audience. Never doubt that you are appreciated and thought of in all the products we develop. You inspire and motivate us to push ourselves to bring you wonders that make you say, "wow."

As a special nod and thank you to the many of you who supported Palladium via the Northern Gun One crowdfunding, I have included as many of you as possible (nearly 250, at last count) as NG robot designers and other characters in Northern Gun. More names will appear in Northern Gun Two. I hope you enjoy becoming an official part of the *Rifts® Megaverse®*.

Dare to dream and keep those imaginations burning bright. Game on.

– Kevin Siembieda, Publisher, Writer & Creator of Rifts®

Experience Tables

Bush Pilot O.C.C.

1	0,000 - 1,970
2	1,971 - 3,940
3	3,941 - 7,880
4	7,881 - 14,880
5	14,881 - 21,880
6	21,881 - 31,880
7	31,881 - 41,220
8	41,221 - 54,440
9	54,441 - 74,660
10	74,661 - 104,880
11	104,881 - 139,220
12	139,221 - 189,440
13	189,441 - 239,660
14	239,661 - 290,880
15	290,881 - 340,000

NG Loss Prevention Officer (LPO)

1	0,000 - 2,150
2	2,151 - 4,300
3	4,301 - 8,600
4	8,601 - 17,200
5	17,201 - 25,500
6	25,501 - 36,000
7	36,001 - 52,000
8	52,001 - 73,000
9	73,001 - 98,000
10	98,001 - 134,000
11	134,001 - 184,000
12	184,001 - 240,000
13	240,001 - 295,000
14	295,001 - 365,000
15	365,001 - 425,000

NG Police Officer O.C.C.

1	0,000 - 1,925
2	1,926 - 3,850
3	3,851 - 7,450
4	7,451 - 15,000
5	15,001 - 21,500
6	21,501 - 31,500
7	31,501 - 41,500
8	41,501 - 54,000
9	54,001 - 75,000
10	75,001 - 105,000
11	105,001 - 140,000
12	140,001 - 190,000
13	190,001 - 240,000
14	240,001 - 300,000
15	300,001 - 350,000

NG Robot Control O.C.C.

1	0,000 - 2,050
2	2,051 - 4,100
3	4,101 - 8,250
4	8,251 - 16,500
5	16,501 - 24,600
6	24,601 - 34,700
7	34,701 - 49,800
8	49,801 - 69,900
9	69,901 - 95,000
10	95,001 - 130,100
11	130,101 - 180,200
12	180,201 - 230,300
13	230,301 - 280,400
14	280,401 - 340,500
15	340,501 - 400,600

Monster Responder O.C.C.

1	0,000 - 2,100
2	2,101 - 4,200
3	4,201 - 8,400
4	8,401 - 16,500
5	16,501 - 24,600
6	24,601 - 34,700
7	34,701 - 50,000
8	50,001 - 70,000
9	70,001 - 95,000
10	95,001 - 132,000
11	132,001 - 182,000
12	182,001 - 232,000
13	232,001 - 282,000
14	282,001 - 335,000
15	335,001 - 395,000

NG Sales Rep O.C.C.

1	0,000 - 1,875
2	1,876 - 3,750
3	3,751 - 7,250
4	7,251 - 14,100
5	14,101 - 21,200
6	21,201 - 31,200
7	31,201 - 41,200
8	41,201 - 51,200
9	51,201 - 71,200
10	71,201 - 101,500
11	101,501 - 136,500
12	136,501 - 186,500
13	186,501 - 236,500
14	236,501 - 286,500
15	286,501 - 326,500



Quick Find Index

Alternative Fuel Systems	101	Mega-Crossbow	205
Anti-Monster (see Gunwolf)	129	Menominee “Pirate’s Point”	51
Anti-Monster HEX Grenades (see Grizzly)	138	Mines	216
Anti-Monster Rail Gun Rounds	132	Nano-Robot Medical Systems	151
Anti-Monster: Wolf’s Head Weapon Platform	133	NG, the City of	32
Anti-Monster: Wolf’s Howl	133	NG, List of Corporate Officers	34
Anti-Monster: Wooden Spike Thrower	140	NG Credits (see The NGMI Credit System)	23
Bangsticks Start (new)	206	NG Giant Defensive Bunkers	32
Big Papa (see Mobile Medical Robot)	147	NG Headquarters, Ishpeming	33
Black Market Relations with NG	25	NG Mercenaries (see IMCN)	62
Bounty Registry: Escanaba office	49	NG O.C.C.s start	76
Bounty Registry: Northern Gun	73	NG Police	82
Building Size in NG	34	NG Policy on Corporate Espionage	16
Chaff Launchers (see Grizzly)	137	NG Policy on D-Bees	16
Chainsaw	150	NG Policy on Magic	15
Chainsaw Pincer	170	NG Policy on Returned Merchandise	24
City Rats	31	NG Policy on Reverse-Engineering	18
Combat Racer	157 & 159	NG Policy on Stealing Ideas	17
Combat Racer, illustration	158	NG Policy on Techno-Wizard Items	15
Crossbow, Mega	205	NG Safe Zone	32
Erin Tarn	30	NG Secure Storage Bunkers	31
Escanaba	45	NG Security Zone	32
Escanaba Road	50	O.C.C. Bush Pilot	76
Escanaba Airshow	48	O.C.C. Loss Prevention Officer	78
Experience Tables	220	O.C.C. Monster Responder	80
Explosives	213	O.C.C. NG Police Officer	82
Flamethrower, Forearm	139	O.C.C. NG Robot Control	86
Flamethrower, Heavy	105	O.C.C. NG Sales Rep	88
Flamethrower, Light	117	Particle Beam Weapons Start	201
Freighter Ships	90	Plasma Weapons Start	203
Ghosts (see Plum Island Region)	57	Plexiglass Windows (see Megabot)	158
Grenade Cannon	128	Rail Guns, Start	209
Grenade, HEX	138	Rail Gun Howitzer	143
Grenade Launcher, Beehive	179	Rail Gun Special Ammo (see Gunwolf)	132
Hand Grenades	213	Rail Gun, Variable Bore	173
Heatwave Emitter	189	Robot Rifles (see Super Max)	178
HEX Grenades	138	Robots, start	100
High-Impact Piston Arms	122	Robots, Standard Features	100
Holographic Decoys	173	Scissor Launchers	155
Hovertrains	93	Shield (see Blocker Shield)	120
IM Highway	43	Solar Robot (see Sunfire)	171
Ion Weapons Start	198	Special Rapid-Fire Strafing Burst	114
Ishpeming, City of	32	Strafing Burst	114
Ishpeming, Republic of	29	Tactical Cameras (see Megabot)	160
Junior (see Mini-Mobile Medical Robot)	152	Task Force X	60
Laser Weapons Start	191	Three-D Camera & Holographic Projector	140
LPO (see Loss Prevention Office)	20	Thunder Cannon (see Thundercaster)	182
LPO, O.C.C.	78	Tranquilizer Pistol (new)	204
Map: Upper Michigan/Northern Gun	42	Tranquilizer Rifle (new)	205
Map: Michigan & Surrounding Region	52	Tugboats	93
Medical Robots	147 & 152	Variable Projectile Cannon (see Thundercaster)	182
		Vibro-Blades	218
		Wolf’s Head Weapon Platform	133



Robots: An Alphabetical Listing

Beachmaster Amphibious Combat Robot	103
Behemoth Explorer	106
Behemoth Super-Explorer	107
Bigfoot Combat Robot	112
Bison Combat Robot	116
Blocker Combat Robot	118
Bruiser Combat Robot	120
Buffalo Combat Robot	123
Bulldog Combat Robot	124
Grizzly Combat Robot	134
Gunbot Combat Robot	126
Gunwolf Combat Robot	129
Hunter Mobile Gun NG-V7 'Original'	141
Hunter Mobile Gun NG-V7, Block IV	143
Megabot NG-M57-2N1 (Multibot reboot)	156
Mini-Mobile Medical Robot 'Junior'	152
Mobile Medical Robot 'Big Papa'	147
Multibot NG-M56 'Original'	154
Ogre EXC-17 Explorer & Construction	160
Okemos Explorer	163
Scorpion Battler	167
Sunfire Combat Robot	171
Super Labor Robot 'Original'	174
Super Max Combat Robot	175
Thundercaster Combat Robot	180
Viking Combat Robot	184
Volcano Combat Robot	187

Also from Palladium Books®

The following titles all tie in with Rifts® Northern Gun One and Two.

Rifts® World Book 34:

Northern Gun™ Two

More information about the weapons, vehicles and practices of Northern Gun, including the new rage of robot gladiatorial combat.

- NG robot haulers and drones.
- NG power armor suits; an expansive range.
- NG body armor; an expansive range.
- NG bionics, cybernetic services and other equipment.
- NG hovercycles, land vehicles and combat vehicles.
- NG jet packs and aircraft.
- NG boats, ships and submarines.
- NG Robot Gladiatorial Arena.
- Robot Gladiator O.C.C. and robot gladiators.
- Pirates and more.
- Written by Matthew Clements and Kevin Siembieda.
- Interior Artwork by Chuck Walton, Nick Bradshaw, and others.
- Wraparound cover by John Zeleznik.
- 192 pages – Cat. No. 888. Coming soon.

Rifts® Coalition Navy™ Sourcebook

- CS naval power armor, warships, aircraft & weapons.
- Pirate, Privateer and Merchant Marine O.C.C.s.
- CS Naval O.C.C.s like the Commando and CS Sea Dog.
- 10 monsters of the Great Lakes and other dangers.
- TW weapons, locations, adventure ideas, more.
- 128 pages. Written by Patrick Nowak. Available now.

Rifts® Mercenaries

- O.C.C.s include Smuggler, Forger, Spies, Bounty Hunter & more.
- Naruni, Wellington, and Golden Age Weaponsmiths weapons & gear.
- Merc Companies, company creation rules & much more.
- Iron Heart and other weapons and gear.
- 160 pages. Written by Carella and Siembieda. Available now.

Rifts® MercTown™

- Entire MercTown mapped and described.
- 204 key locations. Each a potential catalyst for adventure.
- Merc companies, gangs, and many characters.
- 160 pages. Written by Pat Novak and Siembieda. Available now.

Rifts® Merc Ops™

- NG, Wilk's, Wellington and other weapons and gear.
- Techno-Wizard weapons and devices.
- Top Ten Most Wanted, adventure ideas & more.
- 160 pages. Written by Nowak, Bellaire and Siembieda. Available now.

Rifts® Black Market

- Everything you need to know about the Black Market.
- Black Market leaders, dozens of weapons, armor, and more.
- Smuggling robots, traveling shows, and much more.
- 10 Black Market criminal O.C.C.s.
- 5 Black Market Factions, plus all kinds of new weapons & gear.
- Traveling shows, circuses, freak shows and more.
- 192 pages. Written by Clements, Bellaire and Siembieda. Available now.

Rifts® Xiticix Invasion™

- Everything you need to know about the Xiticix, their powers and culture.
- 10 different Xiticix, their Queen, hierarchy, weapons & hives.
- Psi-Stalker tribes and their war with the Xiticix.
- CS operations in Xiticix territory.
- 160 pages. Written by Kevin Siembieda. Available now.

Rifts® Canada

- An overview of Canada and key places. Fadetowns included.
- 18 D-Bees and monsters of Canada plus demons and spirits.
- 5 different Headhunter O.C.C.s. Cold weather rules.
- The Inuit Shaman O.C.C., maps and much more.
- 192 pages. Written by Kevin Siembieda. Available now.

**Palladium products found in
game stores everywhere**

www.palladiumbooks.com

One game system – an endless Megaverse® of adventure™



Megaverse® Insider
Digital Edition

Palladium
Books Inc.
www.palladiumbooks.com